

ABDELMOHSEN, S., EL-KHOULY, T., MALLASI, Z. and BENNADJI, A. (eds.) 2021. *Proceedings of the 9th Arab Society for Computer Aided Architectural Design (ASCAAD) international conference (ASCAAD 2021): architecture in the age of disruptive technologies: transformation and challenges*, 2-4 March 2021, [virtual conference]. Aberdeen: Robert Gordon University [online]. Available from: <http://ascaad.org/conference/2021/docs/proceedings.pdf>

Proceedings of the 9th Arab Society for Computer Aided Architectural Design (ASCAAD) international conference (ASCAAD 2021): architecture in the age of disruptive technologies: transformation and challenges

ABDELMOHSEN, S., EL-KHOULY, T., MALLASI, Z. and BENNADJI, A. (eds.)

2021

///////// Cairo, Egypt
///// March 2-4, 2021
// VIRTUAL CONFERENCE



Architecture in the Age of Disruptive Technologies

Transformation and Challenges

ASCAAD 2021

PROCEEDINGS

9th International Conference
of the Arab Society for
Computer Aided Architectural Design

Edited by
Sherif Abdelmohsen | Tamer El-Khouly | Zaki Mallasi | Amar Bennadji



// 9th International Conference
// of the Arab Society for
// Computer Aided
// Architectural Design



<https://www.linkedin.com/company/ascaad>



<https://www.facebook.com/ascaad>



PROCEEDINGS

The 9th International Conference
of the Arab Society for
Computer Aided Architectural Design

ONLINE CONFERENCE

2 – 4 March 2021
Cairo, Egypt
Department of Architecture
The American University in Cairo (AUC)

EDITED BY

Sherif Abdelmohsen | Tamer El-Khouly | Zaki Mallasi | Amar Bennadji

EDITORS

Sherif Abdelmohsen, Department of Architecture, The American University in Cairo, Cairo, Egypt

Tamer El-Khouly, Department of Architecture, The American University in Cairo, Cairo, Egypt

Zaki Mallasi, AECOM, Baltimore, USA

Amar Bennadji, Scott Sutherland School of Architecture, Robert Gordon University, UK

1ST EDITION, MARCH 2021

Architecture in the Age of Disruptive Technologies: Transformation and Challenges – Proceedings of the 9th International Conference of the Arab Society for Computer Aided Architectural Design

Edited by Sherif Abdelmohsen, Tamer El-Khouly, Zaki Mallasi, Amar Bennadji

ISBN: 978-1-907349-20-1

2021© Arab Society for Computer Aided Architectural Design (ASCAAD)

Published by Robert Gordon University, The Scott Sutherland School of Architecture and Built Environment, Garthdee House, Garthdee Road, Aberdeen, AB10 7QB, Scotland, UK.

All rights reserved. Subject to statutory exception and to the provisions of relevant collective licensing agreements, no part of this publication may be reproduced in any material form (including photocopying or storing in any medium by electronic means whether or not transient or incidentally to some other use of this publication) without the permission of the copyright holder except in accordance with the provisions of the Copyright Designs and Patents Act 1988. Authors of articles in this volume are authorised to use their own material freely.

Applications for the copyright holder's written permission to reproduce any part of this publication should be addressed to ASCAAD.

ASCAAD DECLARATION

Articles edited in this volume were refereed by members of the International Scientific Review Committee in a process that involve detailed reading of the papers, reporting of comments to authors and modifications of manuscripts by authors. The re-evaluation of resubmitted articles was done by the scientific committee members to ensure quality of content.

ORGANIZATION



ASCAAD



SPONSORS



AUC SUPPORT TEAM

Ayman Abdellatif
Sameh Youssef
Marco Hanna
Aly Ibrahim
Rana Geith

Donia Haggag
Amr Maghraby
Youstina Galal
Fatma Farrag
Jala Gadallah

Nader Lotfy
Nesrien Naguib
Omar Rizk
Hossam Mahmoud

ASCAAD SPECIAL SUPPORT

Sema Alacam
Huda Salman

Mostafa Alani
Samar Allam

ABOUT ASCAAD

ASCAAD is a society of those who teach, conduct research and practice in computer-aided architectural design (CAAD) in the Arab World regions of West Asia, and North Africa. ASCAAD is also active in Central Asia, Sub-Sahara Africa, and the Mediterranean. The society holds conferences and educational events that will be hosted by a different University each time. The output of the conferences and contributions from the educational events be published as a Conference Proceedings book. ASCAAD aims to facilitate communication and information exchange regarding the use of digital design technology in architecture, planning and building science that are dramatically challenging our fundamental assumptions, theories, and practices of conventional design paradigm.

أسكاد هي جمعية لأساتذة التدريس و المهندسين و القائمين بالبحث في مجال التصميم المعماري بمساعدة الحاسوب في كليات العمارة والتصميم والهندسة في العالم العربي بشطريه في غرب قارة آسيا و شمال إفريقيا. ينشط أسكاد كذلك في مناطق وسط آسيا و جنوب الصحراء الأفريقية و حوض البحر الأبيض المتوسط. تعقد الجمعية المؤتمرات والفعاليات التعليمية التي ستستضيفها جامعة مختلفة في كل مرة، و يتم نشر مخرجات المؤتمرات والمساهمات من الأحداث التعليمية ككتاب وقائع المؤتمر. وتهدف أسكاد إلى تسهيل التواصل وتبادل المعلومات فيما يتعلق باستخدام تكنولوجيا التصميم الرقمي في الهندسة المعمارية والتخطيط وعلوم البناء التي تتحدى بشكل كبير افتراضاتنا ونظرياتنا وممارساتنا لنموذج التصميم التقليدي.

Board of Directors

Sherif Abdelmohsen (President)

American University in Cairo, Egypt

Huda Salman (Vice President)

Robert Gordon University, United Kingdom

Mohammed Fekry

Effat University, Saudi Arabia

Ahmed Shehata

Umm Al Qura University, Saudi Arabia

Samar Allam

Modern Sciences and Arts University, Egypt

Amar Bennadji

Robert Gordon University, United Kingdom

Salah Chaouche

Université de Constantine 3, Algeria

Mostafa Alani

Aliraqia University, Iraq

Sema Alaçam

Istanbul Technical University, Turkey

Mohamed Maher

DesignTech, Egypt

مجلس الأمناء

شريف عبدالمحسن (الرئيس)

الجامعة الأمريكية بالقاهرة، مصر

هدى سلمان (نائب الرئيس)

جامعة روبرت جوردون، المملكة المتحدة

محمد فكري

جامعة عفت، المملكة العربية السعودية

أحمد شحاتة

جامعة أم القرى، المملكة العربية السعودية

سمر علام

جامعة ٦ أكتوبر للعلوم الحديثة والآداب، مصر

عمار بن ناجي

جامعة روبرت جوردون، المملكة المتحدة

صلاح شاوش

جامعة قسنطينة ٣، الجزائر

مصطفى العاني

الجامعة العراقية، العراق

سما العكام

جامعة اسطنبول التقنية، تركيا

محمد ماهر

شركة ديزاين تك، مصر

PREFACE

This book comprises the Proceedings of the 9th International Conference of the Arab Society for Computer Aided Architectural Design (ASCAAD 2021), held as an online event, from March 2-4, 2021 at the Department of Architecture, The American University in Cairo, Cairo, Egypt. The proceedings contain the 58 accepted papers. All papers are also available digitally at CumInCAD (Cumulative Index of Computer Aided Architectural Design) – <http://papers.cumincad.org>.

Conference Theme

The ASCAAD 2021 conference theme is ***ARCHITECTURE IN THE AGE OF DISRUPTIVE TECHNOLOGIES – Transformation and Challenges***. The theme addresses the gradual shift in computational design from prototypical morphogenetic-centered associations in the architectural discourse. This imminent shift of focus is increasingly stirring a debate in the architectural community and is provoking a much needed critical questioning of the role of computation in architecture as a sole embodiment and enactment of technical dimensions, into one that rather deliberately pursues and embraces the humanities as an ultimate aspiration.

We have encouraged researchers and scholars in the CAAD community to identify relevant visions and challenging aspects such as: from the tangible to the intangible, from the physical to the phenomenological, from mass production to mass customization, from the artifact-centered to the human-centered, and from formalistic top-down approaches to informed bottom-up approaches.

A parallel evolving impact in the field of computational design and innovation is the introduction of disruptive technologies which are concurrently transforming practices and businesses. These technologies tend to provoke multiple transformations in terms of processes and workflows, methodologies and strategies, roles and responsibilities, laws and regulations, and consequently formulating diverse emergent modes of design thinking, collaboration, and innovation. Technologies such as mixed reality, cloud computing, robotics, big data, and Internet of Things, are incessantly changing the nature of the profession, inciting novel modes of thinking and rethinking architecture, developing new norms and impacting the future of architectural education.

With this booming pace into highly disruptive modes of production, automation, intelligence, and responsiveness comes the need for a revisit of the inseparable relation between technology and the humanities, where it is possible to explore the urgency of a pressing dialogue between the transformative nature of the disruptive on the one hand and the cognitive, the socio-cultural, the authentic, and the behavioral on the other.

As scholars and thinkers, we must evaluate these nuances in light of the digital humanities and a comprehensive rethinking of the intricate human-machine discourse. ASCAAD 2021 has thus invited submissions of original research papers on the following topics related to computer-aided architectural design:

1) Human-Centered Computation

- Design Cognition
- Creative Design Concepts and Theories
- Human-computer interaction
- Machine learning & deep learning in architecture

2) Emergent Modes of Learning

- Generative and Parametric Design
- New Modes of CAAD Learning
- Design Education
- Design of/for MOOCs
- Interactive Media and Visualization

3) Architectonic Languages

- Digital tools in design & construction
- Shape and Motion Grammars
- Responsive and Interactive Architecture
- Rapid prototyping and digital fabrication
- Design-to-Robotic Production
- Programmable and Smart Materials

4) Technology Integration and Collaboration

- Building Information Modeling (BIM)
- Computer-Supported Design Collaboration
- Virtual/Mixed Reality
- IoT, Cloud Computing and Digital Twinning

5) Computational Enculturation

- Adoptable Built Environments
- Smart Cities
- Digital Heritage
- Digital Architectural Humanities

Submissions and Statistics

The conference theme of ASCAAD 2021 at the American University in Cairo (AUC) has incited wide interest regionally and globally. A double-blind peer review process was implemented using the *OpenConf* system. In the first round of submissions, authors were asked to send abstracts (in English or Arabic) with a maximum of 500 words and one figure. We received in this stage **151 abstracts** by **226 authors** representing **32 countries**. All abstracts were sent anonymously to at least 2 international referees per abstract and were checked in accordance with the quality measures set out for submissions by ASCAAD. As a result, a total of **123 abstracts** were forwarded to the second round of peer review process, where they were invited to submit their full paper submissions. This included one of two types of submissions:

1. Long papers (English or Arabic) that describe well-developed or completed research (max 4000-5000 words, or 14 pages of the ASCAAD 2021 template).
2. Short papers (English or Arabic) that describe research in progress (max 2500 words, or 10 pages of the ASCAAD 2021 template).

The ASCAAD 2021 scientific committee asked authors at this stage to include in their full paper English submissions an Arabic abstract. The committee provided support where needed for non-native Arabic speakers. Full paper submissions were sent anonymously and were reviewed by two to three international referees. The review process was only possible with the generous and professional contribution of the reviewing committee consisting of a total of **68 expert referees** from around the globe.

During the review process, a few papers were not completely elaborated due to the COVID-19 lockdown situation. The full paper submission deadline was extended to accommodate as much as possible the researchers and their work under these challenging circumstances. A final number of **58 full papers** by **129 authors** representing **18 countries** from the Middle East, Europe, Asia, North America, South America, and Australia were identified by the ASCAAD 2021 scientific committee and were invited to submit camera-ready papers.

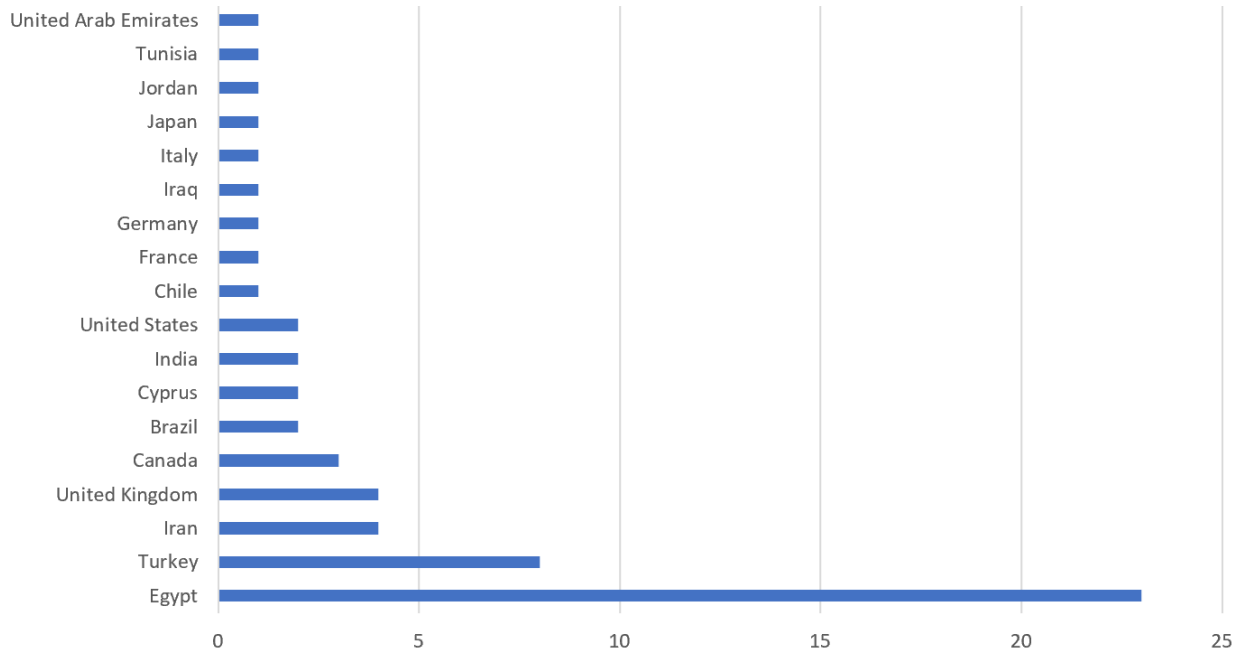

ASCAAD 2021 full paper submissions by country

Out of the 58 full paper submissions, 18 papers (**31%**) were more focused on “**Topic 3: Architectonic Languages**”, involving aspects related to digital fabrication and manufacturing, parametric modeling and generative design, design patterns, data-driven design, adaptive façades, daylighting performance optimization, programmable materials, and shape grammars. 12 papers (**20.7%**) were focused on “**Topic 4: Technology Integration and Collaboration**”, involving aspects of building information modeling, evolutionary algorithms, spatial layout planning, design decision-making, sustainable design, and hygiene-conscious space planning. 12 papers (**20.7%**) were focused on “**Topic 5: Computational Enculturation**”, involving aspects related to affective computing, phenomenological evaluation, tangible and intangible heritage preservation, smart cities, digital materiality, human-centered frameworks for analyzing the built environment, and technology-driven participatory design, in different areas across the Middle East region. 8 papers (**13.8%**) were focused on “**Topic 1: Human-Computer Interaction**”, involving aspects related to artificial intelligence and machine learning in design, generative adversarial networks in modeling and analysis, agent-based modeling, tacit knowledge transfer, and human-computer interaction for rule optimization. 8 papers (**13.8%**) were focused on “**Topic 2: Emergent Modes of Learning**”, involving aspects related to immersive virtual reality, online design education during COVID-19, gaming in education, computational making in design education, and parametric design education and theories. A salient and anticipated emergent theme in this conference, especially visible in Topics 2 and 4 was the impact of the COVID-19 impact on different methods, approaches, and techniques, including mixed methods studies to analyze architecture student experiences, online design studios as the new norm in design education, developing computational approaches to support hygiene-conscious space planning, and spatiotemporal modeling of COVID-19 spread in educational settings.

The Virtual Conference

The ASCAAD 2021 conference was hosted virtually at the Department of Architecture at the American University in Cairo (AUC) during the period March 2-4, 2021, a first-time experience for ASCAAD conferences, due to the challenging circumstances of COVID-19. The conference committee has chosen to move ASCAAD 2021 to a virtual setup to ensure the continuity and sustainability of ASCAAD conferences. The five main conference topics were structured in 14 sessions that unfolded in two parallel sessions over the course of two days (March 3rd and March 4th), preceded by a number of 4 pre-conference workshops on March 2nd. This structure is also followed in the organization of the conference proceedings.

The *Eventtus* conference management system was used for both registration in the conference and workshops and the live personalized experience of the conference sessions. We thank the Digital Transformation team at AUC for the support they provided with the *Eventtus* virtual conference platform both prior to and during the conference days.

For the virtual conference setup, the conference committee had asked all authors with accepted full paper submissions to submit, in addition to camera-ready papers, a 6-minute pre-recorded video of their presentations and their bios, affiliations, and social media links. This allowed for creating a more engaging setup during the conference days. In the *Eventtus* platform, each parallel session comprised basic data about the presenting authors, the paper PDF camera-ready article, and the pre-recorded video presentation, to allow the audience to inspect relevant paper material and author information 2-3 days prior to the conference days to enrich the live discussion and feedback session. Each presenting author was allowed 6 minutes to give their live presentation, allowing for a 25-30 minutes extended discussion moderated by session chairs. Live sessions were broadcasted via *Eventtus* which allowed presenting authors and moderators to test their audiovisual access in a backstage setup 15 minutes prior to their allocated presentation time. In the event of a no-show or technical challenge, the moderators or AUC IT team would play the pre-recorded video presentations on behalf of the authors. Keynote speakers went through technical preparation sessions prior to the conference days, where they tested their connection and audiovisual material and familiarized with the virtual conference management platform.

Aside from the formal conference sessions, and in an effort to convert the in-person component of a physical conference into an all-online virtual conference experience, a “virtual 3D lobby space” (<https://www.ascaad.org/conference/2021/virtual.htm>) was introduced to give the audience a flavor of the conference venue. This virtual space mirrored an existing outdoor area of the AUC campus (the area outside *Bassily Auditorium Moataz Al Alfi Hall*). Using hyperlinks, registered participants could navigate through most conference activities, including access to the conference agenda and running live sessions on *Eventtus*, workshop live sessions, keynote speech details, and a virtual tour of the AUC campus.

In addition, and for the purpose of a more engaging setup, a “virtual break area” was introduced as part of the 3D lobby space. In this space, registered participants and the general audience could access different venues, including virtual sponsor booths, virtual student galleries featuring works of undergraduate and graduate AUC students, and a virtual chatroom. Another virtual video gallery of computational design AUC student and alumni work was available on the *Eventtus* platform. During the “virtual social event” on March 3rd, all registered participants were invited to log in to the virtual chatroom that was available thanks to the *Spatial.Chat* platform. This allowed for a more engaging informal experience and freely formed discussion clusters among conference participants, with some light oriental music and video streaming in the background.

Sherif Abdelmohsen, Tamer El-Khouly, Zaki Mallasi, Amar Bennadji
ASCAAD 2021 Conference Chair and Co-Chairs

WELCOME NOTE – DEPARTMENT OF ARCHITECTURE, AUC

Dear colleagues and researchers

The Department of Architecture at the American University in Cairo (AUC) is honored to host the 9th International Conference of the Arab Society for Computer Aided Architectural Design (ASCAAD 2021). AUC has long been the hub of culture, knowledge, and innovation at both the national and international levels. We are committed to excellence in research and teaching. At the department of architecture, we aim through AUC’s unique interdisciplinary and liberal arts education environment to engage in a wide variety of innovative explorations and pathways that address fast paced and dynamic regional and global challenges.

The ASCAAD conference is a manifestation of a venue that is attuned with our direction to engage in critical discussions about disruptive technologies, digital humanities, sustainable development, computational enculturation, and many other aspects that impact the architectural discourse. It has become evident in recent times that computational culture is increasingly presenting itself as a driver for much of our process and decision making in architecture and urban design. The transformation and challenges introduced by disruptive technologies – the main theme of this conference – have triggered quite an interesting and much needed debate in the architectural community. The very notion of what counts now as “disruptive” versus a “new normal” is quite intriguing and opens a new pathway of research inquiry within and across numerous disciplines, let alone new cross talk within the architectural computing discipline. Within this unique virtual conference setup, these topics are definitely at the core of the discussion among researchers, practitioners, educators, and students who are participating in ASCAAD 2021.

Hosting this conference has been such a pleasure. We look forward to extending another face-to-face invitation to all conference participants in Egypt and at AUC. Special thanks are due to the AUC President Francis Ricciardone, AUC Board of Trustees, Provost Ehab Abdel-Rahman and Associate Provost Alaa El-Din Adris for their continuous promotion and encouragement of hosting and supporting such activities and venues. Special thanks to Professor Ahmed Sherif who has initiated this effort as former Department Chair. Many thanks to our distinguished keynote speakers who have taken from their time and highly enriched the conference and sparked a lot of enthusiasm with their insights and reflections. A final Thank You to the ASCAAD 2021 scientific and organizing committee and to ASCAAD Board of Directors for their excellent efforts in making this conference a success.

Basil Kamel
Chair, Department of Architecture
The American University in Cairo (AUC)

FOREWORD – ASCAAD

Dear ASCAAD friends,

The 9th International Conference of the Arab Society for Computer Aided Architectural Design (ASCAAD 2021) has invited scholars, researchers and students worldwide to address methodologies, approaches, and processes within the framework of disruptive technologies in the architectural discourse. The ASCAAD community has been highly motivated, on top of confirming its presence since its last conference in 2016, to work on this exciting theme in the city of Cairo and together with a leading institution in Egypt and the Middle East; the American University in Cairo (AUC). Faced with a global crisis due to the COVID-19 outbreak, a joint decision and adjustment however had to be made to move to a virtual conference.

If there is one silver lining to the pandemic, it is that the CAAD community has come closer, both at the regional and global level. The ASCAAD community is now on a positive trajectory to develop stronger ties within its regional networks and much tighter bonds with sister organizations. Indeed a *disruptive* time this is that has shaken the whole world but that has however created a platform for engagement and opportunities for closer collaboration in the CAAD community.

As president of ASCAAD, I cannot but express my deep gratitude and optimism working side by side with a highly enthusiastic, active and committed group of researchers and scholars within the Arab World and the Middle East. This conference would not have been possible without the year-round dedication and commitment from conference committee members and previous ASCAAD presidents Zaki Mallasi and Amar Bennadji, and AUC faculty member and colleague Tamer El-Khouly, whose spirit of cooperation and generosity throughout this past year has been exceptionally rewarding and key to the success of this conference. Furthermore, and since September 2020, the newly elected ASCAAD Board of Directors has pumped much needed energy into the organization and have provided incessant support to the making of this conference.

I cannot but thank deeply all members of the CAAD community who have offered consistent support to ASCAAD. Special thanks and gratitude to presidents of ACADIA Jenny Sabin and Kathy Velikov, president of eCAADe Birgül Çolakoğlu, president of CAADRA Christianne Herr, and president of SIGraDi David Sperling for their endless endorsement and encouragement.

Sherif Abdelmohsen
President of ASCAAD

ACKNOWLEDGMENTS

First and foremost, we thank all paper authors whose work was featured in this virtual conference for their hard work, dedication and commitment during the challenging pandemic circumstances. We are grateful to our distinguished keynote speakers *Dr Patrik Schumacher, Dr Dennis Shelden, Dr Christian Derix, and Dr Hanaa Dahy* for their extremely insightful talks and for their generous commitment to the conference. We would also like to thank the pre-conference workshop moderators *Joy Mondal, Ahmed Hassab, Hossameldin Mohammed, Marcelo Bernal, Mohammadjavad Mahdavinejad, and Shahaboddin Fathi* for the highly interesting workshop sessions they conducted prior to the conference.

We would also like to extend our thanks and gratitude to all session chairs who represented all CAAD sister organizations. Thanks also to sister organization presidents who facilitated this session moderation effort as well as provided the conference committee with supporting material and announcements for upcoming CAAD activities around the world. Without the support of *eCAADe, ACADIA, CAADRIA, SIGraDi, and CAAD Futures* and their generous support of all ASCAAD 2021 activities, this conference would not have achieved this success and global recognition. Many thanks to the 68 members of the international reviewing committee who have worked tirelessly to support the double-blind peer review process and the evaluation of 151 abstracts and 123 full papers. Such a demanding task in a tight timeline and working within challenging circumstances is highly appreciated.

At AUC, thanks are due to AUC Provost *Ehab Abdel-Rahman* and Associate Provost *Alaa El-Din Adris* for their support since February 2020 in making this conference happen, the Chair of the Department of Architecture *Basil Kamel* for his endless support, Professor *Ahmed Sherif* for his instrumental role in initiating this effort, and to all AUC administration and Architecture department faculty members. Gratitude and thanks to conference sponsors *Kemet Corporation*, especially to *Tawfik Elrashidy* and *Omar Madkour*, and *CAD Masters*, especially to *Taher Saied* for their generous contribution. All thanks to the dedicated conference committee members *Sherif Abdelmohsen, Tamer El-Khouly, Zaki Mallasi* and *Amar Bennadji*, and the support of ASCAAD members *Huda Salman, Sema Alacam, Mostafa Alani* and *Samar Allam*.

Warmest regards and thanks to the unknown soldiers behind this success teaching assistants and alumni *Youstina Galal* and *Omar Rizk* who worked tirelessly on the development of the virtual venue, 3D virtual experience and student video gallery, the Architecture Association (AA) at AUC, especially *Rana Geith* and *Jala Gadallah*, for providing the student material for the virtual galleries, and to *Aly Magdy* and *Fatma Farrag* for their support in the conference graphics, banners, posters and virtual walkthrough setup. Thanks to the Department of Architecture Executive Assistant *Rehab Habashy*, Technical Operations Manager *Hatem Diab* and IT staff *Hossam Mahmoud* for their endless support and facilitation throughout the conference activities, and technical and financial procedures.

Special thanks to the dedicated Digital Transformation team at AUC without whose support this virtual conference setup would not have been possible. Thanks to AUC Senior Vice President *Ayman Abdellatif* for his guidance throughout the process. Thanks to *Donia Haggag* and *Nader Lotfy* who facilitated the launch of the virtual setup, and to the *Eventtus* Support Team who worked round the clock before and during the conference venue to make things happen, especially *Sameh Youssef, Amr Maghraby, Nesrien Naguib*, and *Marco Hanna*.

Cairo, March 2021

Sherif Abdelmohsen, Tamer El-Khouly, Zaki Mallasi, Amar Bennadji
ASCAAD 2021 Conference Chair and Co-Chairs

SCIENTIFIC REVIEW COMMITTEE

ABUBAKR MERGHANI

University of Khartoum, Sudan

AHMED OKEIL

Abu Dhabi University, UAE

AHMAD RAFI

Multimedia University, Malaysia

AHMED EL ANTABLY

Arab Academy for Science and Technology, Egypt

AHMED SHERIF

American University in Cairo, Egypt

AMAR BENNADJI

Robert Gordon University, United Kingdom

ANDRES CAVIERES

University of Oklahoma, United States

ANDREW LI

Kyoto Institute of Technology, Japan

ANIS SEMLALI

American University in Ras Al-Khaimah, UAE

ANTONIO FIORAVANTI

Sapienza University of Rome, Italy

ASTERIOS AGKATHIDIS

University of Liverpool, United Kingdom

ATSUKO KAGA

Osaka University, Japan

AULIKKI HERNEOJA

University of Oulu, Finland

AYMAN OTHMAN

British University in Egypt, Egypt

AYMAN WAGDY

University of Queensland, Australia

BENAY GURSOY

Penn State University, United States

BIRGUL COLAKOGLU

Istanbul Technical University, Turkey

BOB MARTENS

TU Wien, Austria

BURAK PAK

KU Leuven, Belgium

CRISTINA CAMELO GOMES

University of Lisbon, Portugal

DANIELA FROGHERI

Universidad de Monterrey, Mexico

DAVID SPERLING

University of Sao Paulo, Brazil

DINA TAHA

Alexandria University, Egypt

EBTISSAM MOUSTAPHA

The Knowledge Hub, Coventry University, Egypt

EHAB KAMEL

University of Central Lancashire, United Kingdom

ELIF ERDINE

Architectural Association, United Kingdom

FEHMI DOGAN

Izmir Institute of Technology

FRANK PETZOLD

Technical University of Munich, Germany

GABRIELA CELANI

University of Campinas, Brazil

GUZDEN VARINLIOGLU

Izmir University of Economics

HENRI ACHTEN

Czech Technical University in Prague, Czechia

HUDA SALMAN

Robert Gordon University, United Kingdom

HUGO SHEWARD

University of Kansas, United States

JOACHIM KIEFERLE

Hochschule RheinMain, Germany

KATHY VELIKOV

University of Michigan

KHALED TARABIEH

American University in Cairo

LISS WERNER

Technische Universität Berlin, Germany

ALAA MANDOUR

Helwan University, Egypt

MADY MOHAMED

Effat University, Saudi Arabia

MAGDY IBRAHIM

Abu Dhabi University, UAE

MAHER ELKHALDI

Rivian, United States

MARC AUREL SCHNABEL

Victoria University of Wellington, New Zealand

MARCELO BERNAL

Perkins & Will, United States

MERVAT EL-SHAFIE

Effat University, Saudi Arabia

MOHAMMED FEKRY

Effat University, Saudi Arabia

MOSTAFA ALANI

Aliraqia University, Iraq

ÖZGÜN BALABAN

TU Delft, Netherlands

PABLO HERRERA

Universidad Peruana de Ciencias Aplicadas, Peru

PANAGIOTIS PARTHENIOS

Technical University of Crete, Greece

PAULA GOMEZ

Georgia Tech Research Institute, United States

PEDRO SOZA

Universidad de Chile, Chile

PIERRE COTE

Universite Laval, Canada

RODRIGO MARTIN IGLESIAS

University of Buenos Aires, Argentina

ROKIA RASLAN

UCL, United Kingdom

RUDI STOUFFS

National University of Singapore, Singapore

SAMIR HOSNY

Future University in Egypt, Egypt

SAMAR ALLAM

Modern Sciences and Arts University, Egypt

SEMA ALAÇAM

Istanbul Technical University, Turkey

SEVIL YAZICI

Istanbul Technical University, Turkey

SHERIF ABDELMOHSEN

American University in Cairo, Egypt

TAMER EL-KHOULY

American University in Cairo, Egypt

THOMAS GRASL

SWAP Architects, Austria

TOMAS DORTA

University of Montreal, Canada

TOMOHIRO FUKUDA

Osaka University, Japan

Wael ABDELHAMEED

Applied Science University, Bahrain

YASSER SAKR

Helwan University, Egypt

YEHIA MADKOUR

Perkins & Will, Canada

ZAKI MALLASI

AECOM, United States

SESSION CHAIRS

AMAR BENNADJI

Robert Gordon University, United Kingdom

DAN LUO

University of Queensland, Australia

FERNANDO LIMA

Penn State University, United States

FREDERICO BRAIDA

Federal University of Juiz de Fora, Brazil

GABRIELA CELANI

University of Campinas, Brazil

HALIL ERHAN

Simon Fraser University, Canada

HENRI ACHTEN

Czech Technical University in Prague, Czechia

HUDA SALMAN

Robert Gordon University, United Kingdom

IMMANUEL KOH

Singapore University of Technology and Design,
Singapore

MOSTAFA ALANI

Aliraqia University, Iraq

DING WEN 'NIC' BAO

Royal Melbourne Institute of Technology, Australia

SEMA ALAÇAM

Istanbul Technical University, Turkey

TAMER EL-KHOULY

American University in Cairo, Egypt

URVI SHETH

CEPT University, India

KEYNOTES



CHRISTIAN DERIX **Principal, Derix & Associates**

Keynote:

Computational Design: From Origin to Urban Computing

[Keynote Speech Video](#)

Christian Derix founded the first 'Computational Design' group in architectural industry and is a global leader in computational urbanism and architectural AI. With 20 years of experience in academic and professional R&D, he is one of the early pioneers at the nexus of human-centric planning with generative design, data science & machine learning.

He is the founder of many state-of-the-art computational planning consultancies. Developing the business strategies and IP behind applied research, he founded and directed: Aedas|R&D and its Computational Design Research [CDR] group in 2004, Woods Bagot's design research agency SUPERSPACE in 2014 and Urban Systems of ERA-co in 2019.

The work of his groups have won awards in various domains such as the 2010 President's Medal commendation of the Royal Institute of British Architects (RIBA) for Research in Practice for its work on the September 11th Memorial Museum in New York; the 2011 Compasso d'Oro Honoray Mention for the first participatory web-based furniture system called VITA in Milan; the 2012 CTBUH Innovation Award for the Activated Façade for the Al Bahr Towers in Abu Dhabi; and the 2019 Fast Company 'World Changing Ideas Awards' Finalist and Honorable Mention in the two categories of 'Spaces, Places and Cities' and 'AI and Data' for the MoreLA urban planning research.

Derix completed his MSc in 2001 by developing the first AI application for urban analytics using artificial neural networks. He holds a PhD from the Technical University Vienna on the subject of 'People, Space and Computation' and has taught and researched the subject across Europe at University College London, University of East London, Politecnico di Milano, TU Vienna, ETH Zurich, TU Munich, IE University Madrid and the University of Sheffield. He co-founded the Centre for Evolutionary Computing in Architecture [CECA] at the University of East London in 2002 with Paul Coates where many of the foundations for AI and machine learning in space planning were laid.



DENNIS SHELDEN

Director, Center for Architecture Science and Ecology (C.A.S.E.), Rensselaer Polytechnic Institute (RPI)

Keynote:

What can we learn from Tech?

Building Industry and Technology Driven Disruption

[Keynote Speech Video](#)

Shelden spent 17 years as an associate of legendary architect Frank Gehry. In 1997, he joined the firm Gehry Partners, where he was responsible for the management and strategic direction of the firm's computing program including the software and process development.

In 2002, he co-founded the spinoff company Gehry Technologies, serving as chief technology officer on the development of several software products and project executives on numerous groundbreaking building projects until the firm's acquisition by Trimble in 2014.

"In terms of moving Rensselaer forward as a global leader in next-generation buildings and smart cities, the appointment of Dennis Shelden as the new director of CASE represents a significant strategic opportunity for the entire Institute," said Evan Douglis, the dean of the School of Architecture. "He has a stellar profile as a leading educator and technologist in the profession of architecture. He approaches complex problems with a visionary stance, and over many years has consistently arrived at highly creative and radically innovative solutions that have contributed to advancing the built environment. We are thrilled to have Dennis Shelden join the School of Architecture at Rensselaer."

Shelden joins Rensselaer from Georgia Tech, where he was an associate professor of architecture, director of the Digital Building Laboratory, and director of the School of Architecture's doctoral program. Shelden was also previously an associate professor of practice in MIT's Design and Computation program, and he held teaching positions at the University of California, Los Angeles and the Southern California Institute of Architecture.



HANAA DAHY

Professor, Biobased Materials and Materials Cycles in Architecture (BioMat), ITKE, University of Stuttgart

Keynote:

Vernacular Architecture of the Digital Age – Triggering a Debate
[Keynote Speech Video](#)

Hanaa Dahy is a registered architect, engineer and material developer who established in the frame of her professorship the research department BioMat (Bio-based Materials and Materials Cycles in Architecture) as a Junior Professor at ITKE (Institute for Building Structures and Structural Design) since July 2016 at the Faculty of Architecture and Urban Planning in the University of Stuttgart. She earned her PHD from ITKE in Stuttgart in 2014 with Excellence and earned her Bachelors and Master Degree in ‘Architectural Engineering’ in 2003, 2006 respectively from Ain Shams University in Cairo with Honors. She established her office in 2003 in Cairo and worked on different architectural projects in Cairo and the Middle East before moving to Germany in 2009 to complete her doctoral studies and to merge her experience with the European architecture and industry.

Dahy raised different sustainability aspects and ecological concerns towards building materials and addressed this in different teaching courses, publications and within collaborations with industrial partners in diverse research-industrial projects.

She developed, designed and manufactured a number of innovative sustainable building products that were widely presented in international exhibitions and attracted a lot of industrial interests. Among other research areas, she is particularly interested in biomimetic principles, sustainability and their impact on architectural practice and applications. She has pending European and international patents, earned the best of Materials and Design award (Materialica) in Munich in 2015 and the Material Prize award (MaterialPreis) in 2016 from the Design Center of the state Baden-Württemberg in Germany, a fellowship for the innovation of university-teaching in 2017, a number of research/industrial project funds and is a member of a number of European and international scientific and professional bodies. Her teaching and training are in the area of architectural design, composites, structure and materials, smart systems, fabrication and biomimetics.



PATRIK SCHUMACHER
Principal, Zaha Hadid Architects (ZHA)

Keynote:

Tectonism: Engineering and Fabrication Logics as Stylistic Drivers

[Keynote Speech Video](#)

Patrik Schumacher is the principal of Zaha Hadid Architects (ZHA) and is leading the firm since Zaha Hadid's passing in March 2016. He joined Zaha Hadid in 1988 and was seminal in developing Zaha Hadid Architects to become a 450 strong global architecture and design brand.

Patrik Schumacher studied philosophy, mathematics, and architecture in Bonn, Stuttgart, and London. In 2010, Patrik Schumacher won the Royal Institute of British Architects' (RIBA) Stirling Prize for excellence in architecture together with Zaha Hadid, for MAXXI, the National Italian Museum for Art and Architecture of the 21st century in Rome. He is an academician of the Berlin Academy of Arts.

In 1996, he founded the Design Research Laboratory at the Architectural Association (AA) in London where he continues to teach. Patrik Schumacher is lecturing worldwide and is currently a guest professor at Tongji University, Shanghai.

In 2008, he coined the phrase "Parametricism" and has since published a series of manifestos promoting Parametricism as the new epochal style for the 21st century. In 2010/2012, he published his two-volume theoretical opus magnum "The Autopoiesis of Architecture". Patrik Schumacher is widely recognized as one of the most prominent thought leaders within the fields of architecture, urbanism, and design.

TECHNICAL WORKSHOPS

Workshop 1:

AI VISION IN DESIGN: MULTISTYLE TRANSFER WITH NEURAL NETWORKS

[Workshop Video](#)

Workshop Moderator:

Joy Mondal, WEsearch Lab, India

Artificial intelligence (AI) and machine learning (ML) have been integrated in the workflow and the creative processes of many industries in the recent years. This 3-hour long workshop is designed to be an introduction (for the uninitiated) to the use of AI and ML in the fields of architecture, design and art. The workshop presents the current state of the art developments, speculates the future trajectory of AI, addresses the concepts of neural networks, and demonstrates (multi) style transfer using neural network. Neural (multi) style transfer uses a pre-trained image classifier to map the “style” of one or more image(s) (analogous to the visual ethos of ‘colour’ and ‘texture’) onto the “content” of another image (analogous to ‘geometry’). The method offers ways of understanding how machines see the world. It will be used to cross-breed architectural visuals (facades, silhouettes, massing, plans, diagrams, sketches, photographs etc.) of various styles, e.g., reimagining the plans of van der Rohe articulated in the style of bulky Baroque plans. The investigations in the workshop provokes deliberations over the role of the machine as the “doer”, the “thinker” or the “creative companion”; the authorship of the final output; and the design implications of cross-breeding artefacts of different styles. The open access nature of the development of AI tools has presented an opportunity to the architecture community to not only borrow the already developed techniques, but also to reinterpret them to supplement our tacit knowledge.

Workshop 2:

ARTIFICIAL INTELLIGENCE-BASED GENERATIVE MODELING

[Workshop Video](#)

Workshop Moderators:

Ahmed Hassab, American University in Cairo, Egypt

Hossameldin Mohammed, University of British Columbia, Canada

The goal of the workshop is to provide participants with the essential knowledge about how to preprocess and build generative architectural models. The program of the workshop includes the steps for data pre-processing, data post-processing and live coding of generative adversarial networks (GANs) and CycleGANs on grasshopper. The procedure includes the general framework that can be applied to any generation process, and a description of the software and computational requirements including required processing and graphics cards, data quality and formats, and harnessing the power of computational platforms such as Google Cloud or Amazon Web Services.

Workshop 3:

DESIGN SPACE CONSTRUCTION: GENERATION, SIMULATION AND DATA ANALYSIS

[Workshop Video Part 1](#), [Workshop Video Part 2](#)

Workshop Moderator:

Marcelo Bernal, Perkins & Will, Atlanta, GA, USA

This workshop introduces a conceptual framework and computational models to explore design spaces, understood as all the possible alternatives produced by combinations of input parameters. The main objective is modeling the complex decision-making process in multidimensional problems. To tackle this challenge, we transit from generation of population of design alternative to the visualization and analysis of data of the performance results of each design option with respect to two typical conflicting objectives: Minimize energy consumption and maximize natural lighting.

Workshop 4:

MASS AND SPACE: AN EXERCISE IN INTERACTIVE ARCHITECTURE TO PROMOTE THE QUALITY OF THE USER EXPERIENCE OF SPACE

[Workshop Video](#)

Workshop Moderators:

Mohammadjavad Mahdavinejad, Tarbiat Modares University, Tehran, Iran
Shahaboddin Fathi, Tarbiat Modares University, Tehran, Iran

This workshop explores new possibilities of mass and space, combines architecture with space and time and shows the impact of movement on architecture. It attempts to enhance the quality of the user experience of space with interactive architecture. The workshop explores how to achieve an inspiring design in interactive architecture and provide a maquette of the final design to create a part using tools such as wood and foam. The workshop activities include using computer design, using Grasshopper or AutoCAD, cutting parts, assembling parts, and finally examining the performance of design components. The significance of the workshop lies in using inspirations from the past to produce interactive architecture, gaining a better understanding of mass and space, reaching a complete experience of human interaction with the environment, and enhancing the quality of the user experience of space.

CONTENTS

About ASCAAD	<i>iv</i>
Preface	<i>v</i>
Welcome Note – Department of Architecture, AUC	<i>ix</i>
Foreword - ASCAAD	<i>x</i>
Acknowledgments	<i>xi</i>
Scientific Review Committee	<i>xii</i>
Session Chairs	<i>xiv</i>
Keynotes	<i>xv</i>
Technical Workshops	<i>xix</i>
D1.P1.S1 HUMAN-COMPUTER INTERACTION I (Video)	6
Applying Machine Learning to Enhance the Implementation of Egyptian Fire and Life Safety Code in Mega Projects	7
<i>Mohamed Albassel, Mustafa Waly</i>	
Briefing AI: From Architectural Design Brief Texts to Architectural Design Sketches	23
<i>Lale Başarır, Kutluhan Erol</i>	
Utilizing Behavioral Agent-Based Modeling in an Automated Integrative Design Process	32
<i>Maziar Heydari, Mohammadjavad Mahdavinejad, Khosro Daneshjoo</i>	
Conditions of Tacit Knowledge Transfer in Architectural Computational Design: An Analytical Review	43
<i>Hala Hossameldin, Ramy Bakir, Sherif Elfiki</i>	
D1.P2.S1 ARCHITECTONIC LANGUAGES I (Video)	57
Designing Facades Based on Daylight Parameter: A Proposal for the Production of Complex Surface Panelization	58
<i>Gizem Özerol, Semra Selçuk</i>	
A Computational Approach for Optimizing the Daylighting Performance of Existing Buildings	69
<i>Mariam El Hussainy, Mohammed Mayhoub, Ahmed El Kordy</i>	
Parametric Simulation and Sensitivity of Light Shelf on Daylighting and Shading: Light Shelf Performance Map	84
<i>Mina Ishac</i>	
Energy and Daylight Performance Optimization of Butterfly Inspired Intelligent Adaptive Façade	99
<i>Ali Najafi, Peiman Pilechiha</i>	
D1.P1.S2 EMERGENT MODES OF LEARNING I (Video)	113
Immersive VR Environment for Construction Detailing Education: BIM Approach	114
<i>Maha ElGewel, Wafaa Nadim, Mostafa Talaat, Ahmad El Kassed, Mohamed Yehia, Slim Abdennadher</i>	
Transforming Learning for Architecture: Online Design Studio as New Norm for Crises Adaptation Under COVID-19	129
<i>Duaa Al Maani, Saba Alnusairat, Amer Al-Jokhadar</i>	

Student Experiences of Online Design Education Post COVID-19: A Mixed Methods Study	142
<i>Ramy Bakir, Sara Alsaadani, Sherif Abdelmohsen</i>	
Parametric Tool to Sketch Sonic Ambiences: Esquissos, A Plugin for Ecological and Educational Issues	156
<i>Theo Marchal, Noha Said</i>	
D1.P2.S2 TECHNOLOGY INTEGRATION AND COLLABORATION I (Video)	166
Against a Workplace Contagion: A Digital Approach to Support Hygiene-Conscious Office Space Planning	167
<i>Mohammed Mekawy, Mostafa Gabr</i>	
Eco-Nudging: Interactive Digital Design to Solicit Immediate Energy Actions in The Built Space	177
<i>Sherif Goubran, Carmela Cucuzzella, Mohamed Ouf</i>	
Built-In Immersive VR Technology for Decision-Making in Design and Simulation of a Flexible Shading Device	190
<i>Odysseas Kontovourkis, Andreas Konstantinou, Nikos Kyrizi, Panagiota Tziourrou</i>	
BIM Execution Plan (BEP) to Infrastructure Superintendence of the Federal University of Pernambuco: A Proposal to Implement BEP in a Federal University in Brazil	201
<i>Isabella Rodrigues, Max Andrade</i>	
D1.P1.S3 ARCHITECTONIC LANGUAGES II (Video)	213
Assessing the Effectivity of Additive Manufacturing Techniques for the Production of Building Components: Implementing Innovation for Housing Construction in Saudi Arabia	214
<i>Mohammad Alabbasi, Han-Mei Chen, Asterios Agkathidis</i>	
A New Paradigm in Generative Design Linking Parametric Architecture and Music to Form Finding	227
<i>Ehsan Ronagh, Mohammadjavad Mahdavinejad, Anoosha Kia</i>	
Digitally Encoded Wood: 4D Printing of Hygroscopic Actuators for Architectural Responsive Skins	241
<i>Rana El-Dabaa, Islam Salem, Sherif Abdelmohsen</i>	
From Immersive to Physical Sketches: A New 3D Representation Mode During Ideation	253
<i>Abdelmounem Taouai, Tomas Dorta</i>	
Augmenting Passive Actuation of Hygromorphic Skins in Desert Climates: Learning from Thorny Devil Lizard Skins	264
<i>Zeyad Aly, Aly Ibrahim, Sherif Abdelmohsen</i>	
D1.P2.S3 COMPUTATIONAL ENCULTURATION I (Video)	279
Social Network Analysis of Digital Design Actors: Exploratory Study Covering the Journal Architectural Design	280
<i>Hanife Sümeyye Taşdelen, Leman Figen Gül</i>	
We Gain a Lot...But What are We Losing? A Critical Exploration of the Implications of Digital Design Technologies on Sustainable Architecture	293
<i>Aristofanis Soulikias, Carmela Cucuzzella, Firdous Nizar, Morteza Hazbei, Sherif Goubran</i>	

The Sericum Via: A Serious Game for Preserving Tangible and Intangible Heritage of Iran	306
<i>Sarvin Eshaghi, Sepehr Afshar, Güzden Varinlioglu</i>	
A Roadmap for Smart City in the Arab Region - A Paradigm Shift in Post-Pandemic Era	317
<i>Samah Elkhateeb, Manal El-Shahat</i>	
D1.P1.S4 COMPUTATIONAL ENCULTURATION II (Video)	329
Affective Computing in Space Design: A Review of Literature of Emotional Comfort Tools and Measurements	330
<i>Mariam Abouhadid</i>	
استخدام برنامج ENVI-met لمحاكاة السلوك المناخي للعنصر الأخضر داخل الفراغات العمرانية	341
<i>Ahmed Fekry, Reham El Dessuki, Mai Abdalaty</i>	
Redefinition of Heritage Public Spaces Using PPGIS: The Case of Religious Complex in Old Cairo	355
<i>Aya Elgobashi, Yasmine El Semary</i>	
Phenomenological BIM Design Evaluation of Indoor Spatial Configurations	371
<i>Noran Elbaz, Mohamed Ezzeldin</i>	
D1.P2.S4 TECHNOLOGY INTEGRATION AND COLLABORATION II (Video)	384
Thermal Performance of Nanomaterials of a Medium Size Office Building Envelope: With a Special Reference to Hot Arid Climatic Zone of Egypt	385
<i>Nouran Ali, Samir Hosny, Ahmed Abdin</i>	
On the Influence of Evolutionary Algorithm (EA) Optimization in Architectural Design: A Reflection through an Architectural Envelope's Shadowing System Design	397
<i>Giuseppe Canestrino</i>	
Eelish: Grasshopper Plugin for Automated Column-Beam Placement on Orthogonal Floor Plans: Formalising Manual Workflow into an Algorithm through Empirical Analysis	407
<i>Joy Mondal</i>	
Spatiotemporal Modeling: Spread of COVID-19 in Educational Settings: The Role of Architecture in A Pandemic	421
<i>Paula Gomez, Khatereh Hadi, Matthew Swarts, Olga Kemenova, Marcelo Bernal</i>	
D2.P1.S1 ARCHITECTONIC LANGUAGES III (Video)	435
Parametric Iranian-Islamic Muqarnas as Drivers for Design for Fabrication and Assembly via UAVs: Parametric Analysis and Synthesis of Iranian-Islamic Muqarnas	436
<i>Erfan Zamani, Theodoros Dounas</i>	
The Customized Habitat: An Exploration of Personality-Induced Mass Customization through Shape Grammars	450
<i>Ahmed Marey, Ahmed Barakat</i>	
Shapegrammar: A Tool for Research in Traditional Architecture	465
<i>Linas Fathima, Chithra K</i>	
Surface Shape Grammar Morphology to Optimize Daylighting in Mixed-Use Building Skin	479
<i>Samar Allam, Soha El Gohary, Maha El Gohary</i>	

D2.P2.S1 EMERGENT MODES OF LEARNING II (Video)	493
Territories Made by Measure: The Parametric as a Way of Teaching Urban Design Theory	494
<i>Matteo Frascini, Julian Raxworthy</i>	
Case Studies of Incorporating BIM Models in the Digital Game Environment: Building Game Environment with BIM Tools and Game Scripts	507
<i>Veli Yönder</i>	
Material-Based Parametric Form Finding: Learning Parametric Design through Computational Making	521
<i>Sherif Abdelmohsen, Passaint Massoud</i>	
X-Max A Digitally Fabricated, Component-Based, Scrap Metal Assembly	536
<i>Michail Georgiou, Odysseas Georgiou, Pavlos Fereos, Eftihis Efthimiou</i>	
D2.P1.S2 COMPUTATIONAL ENCULTURATION III (Video)	550
Technology-Driven Participatory Spatial Design in a Developing World Context: The Case of Istanbul	551
<i>Ahmet Gün, Burak Pak, Yüksel Demir</i>	
Materiality: Linking a Digital Material Framework with the Anthropological Hand	568
<i>Maryam Houda</i>	
	581
<i>Hend Shams El-Din</i>	
A Human-Centred Framework for Sonic Mapping: Developing Representation Methods to Analyze Sonic Environments	592
<i>Adam Hannouch</i>	
D2.P2.S2 HUMAN-COMPUTER INTERACTION II (Video)	602
Human-Computer Interaction for Urban Rules Optimization	603
<i>Alia Belkaid, Abdelkader Ben Saci, Ines Hassoumi</i>	
Fill in the Blanks: Deep Convolutional Generative Adversarial Networks to Investigate the Virtual Design Space of Historical Islamic Patterns	614
<i>Mostafa Alani, Bilal Al-Kaseem</i>	
Generative Design Methodology for Double Curved Surfaces using AI	622
<i>Ahmed Hassab, Sherif Abdelmohsen, Mohamed Abdallah</i>	
A Grasshopper Plug-In for Designing Virtual Camera Path in Rhino 3D using Cellphone Motion: Chameleon	636
<i>Ebrahim Poustinchi</i>	
D2.P1.S3 ARCHITECTONIC LANGUAGES IV (Video)	645
Applying Urban Parametricism in the Design of Dynamic Neighborhoods	646
<i>Marwa Fahmy</i>	
Dynamic Aggregation: Merging Aggregation and Particle-Spring Systems in a Form-Finding Approach	661
<i>Gonzalo Vegas, Francisco Calvo, Marcelo Bernal</i>	

Exploring the Self-Organizing Structure of the Moroccan Medina: A Simulation Model for Generating Urban Form	672
<i>Aqil Cheddadi, Kensuke Hotta, Yasushi Ikeda</i>	
Towards New Design Patterns for Museum Exhibition Halls using Integrated Algorithmic Generative Techniques	686
<i>Hussein Mansour, Sherif Sheta, Medhat Samra</i>	
Data-Driven Design of Adaptive Façades: View, Glare, Daylighting and Energy Efficiency	699
<i>Mahdi Valitabar, Mohammadjavad Mahdavinejad, Henry Skates, Peiman Pilechiha</i>	
D2.P2.S3 TECHNOLOGY INTEGRATION AND COLLABORATION III (Video)	712
Developing a Design Framework for the 3D Printing Production of Concrete Building Components: A Case Study on Column Optimization for Efficient Housing Solutions in Saudi Arabia	713
<i>Mohammad Alabbasi, Han-Mei Chen, Asterios Agkathidis</i>	
Double Green Façades using Parametric Sustainable Design: A Simulation Tools with Parametric Approach to Improve Energy Performance of Office Buildings in Egypt	727
<i>Ayah Ramadan</i>	
Man-Machine Interaction in the Evaluation of Airport Design Process in Brazil	742
<i>Italo Guedes, Max Andrade</i>	
User-Friendly Tool to Enable Individual Homeowners to Invest in Energy Efficiency	750
<i>Mohammed Seddiki, Amar Bennadji, Richard Laing, David Gray</i>	

D1.P1.S1

HUMAN-COMPUTER INTERACTION I

APPLYING MACHINE LEARNING TO ENHANCE THE IMPLEMENTATION OF EGYPTIAN FIRE & LIFE SAFETY CODE IN MEGA PROJECTS

MOHAMED ALBASSEL, MUSTAFA WALY

BIM Specialist, Dar Al-Handasah (Shair & Partners)

Email address: moh.albassel@gmail.com

Senior Architect and Technical Team Leader, Studio Five

Email address: mustafa.waly93@gmail.com

Abstract. Machine Learning has become a significant research area in architecture; it can be used to retrieve valuable information for available data used to predict future instances. the purpose of this research was to develop an automated workflow to enhance the implementation of The Egyptian fire & life safety (FLS) code in mega projects and reduce the time wasted on the traditional process of rooms' uses, occupant load, and egress capacity calculations to increase productivity by applying Supervised Machine Learning based on classification techniques through data mining and building datasets from previous projects, and explore the methods of preparation and analyzing data (text cleanup-tokenization- filtering- stemming-labeling). Then, provide an algorithm for classification rules using C# and python in integration with BIM tools such as Revit-Dynamo to calculate cumulative occupant load based on factors which are mentioned in the Egyptian FLS code, determine classification and uses of rooms to validate all data related to FLS. Moreover, calculating the egress capacity of means of egress for not only exit doors but also exit stairs. In addition, the research is to identify a clear understanding about ML and BIM through project case studies and how to build a model with the needed accuracy.

Keywords: *Building information modeling (BIM), Artificial intelligence (AI), Machine learning (ML), Data mining, Computational design, fire and life safety, passive fire protection, classification.*

ملخص. لقد أصبح التعلم الآلي مجالاً مهماً للبحث العلمي في الهندسة المعمارية، و يمكن استخدامه للتنبؤ بالحالات المستقبلية عن طريق تحليل و استخراج البيانات القيمة الحالية. الغرض من هذا البحث هو تطوير سير عمل آلي لتعزيز تنفيذ الكود المصري للأسس التصميم و اشتراطات التنفيذ لحماية المنشآت من الحريق في المشاريع الضخمة و تقليل الوقت المستخدم

في حسابات سعة الخروج وحمل الاشغال و تصنيف استخدامات الفراغات و ذلك عن طريق تطبيق خوارزميات تقوم بالتصنيف و حساب الحمل التراكمي للركاب و حساب سعة الخروج لوسائل الخروج ليس فقط لأبواب الخروج ولكن أيضًا لسلام الخروج باستخدام لغة البرمجة #C بالتكامل مع أدوات نمذجة معلومات المباني استنادًا إلى العوامل المذكورة في الكود المصري لأسس التصميم و اشتراطات التنفيذ لحماية المنشآت من الحريق مما يؤدي الي زيادة الإنتاج و توفير الوقت. بالإضافة إلى ذلك، يهدف البحث إلى تحديد فهم واضح حول نمذجة معلومات المباني و التعلم الآلي من خلال دراسة حالة لمشروع و بناء نموذج بالدقة المطلوبة.

الكلمات المفتاحية: نمذجة معلومات البناء، الذكاء الاصطناعي، التعلم الآلي، التنقيب عن البيانات ، التصميم الحسابي ، الحماية من الحرائق ، التصنيف.

1. Introduction

construction industry in (MENA) Middle East and North Africa is growing tremendously fast, and these projects are considered as mega projects due to the scale and complexity of geometries of projects. In addition, they need to be constructed in minimum duration with high quality and low budget. Thus, it generates inefficiencies and various challenges similarly experienced in global construction industry context. These include low profitability, inefficiency, fragmentation, lack of collaboration, and fast track projects causing cost and time overruns. Building Information Modelling (BIM) is anticipated to improve the current performance of the global construction industry and use machine learning to revolutionize architectural design and production. Machine learning provides more accurate information without wasting time that is reflected on decreasing the project budget.

Despite the benefits and potentials of BIM and ML technologies, they are not applied in the AEC industry in Egypt just like many other regions of the world. Therefore, the purpose of this research is to develop a clear understanding of ML and to implement an automated workflow using fire and life safety codes by the practitioners in the AEC industry.

1.1 PROBLEM STATEMENT

It is believed that the process of producing fire and life safety drawings takes tremendous time because of the calculation criteria which is based on a particular fire code such as, NFPA, Egyptian Fire Code, and Saudi Fire Code SBC 801. The aim of this paper is to diminish the time taken to finalize the calculations and presentations of data of a specific project based on Machine learning technique and add all the data required for all projects.

In other words, to calculate the occupant load of a certain project, it is needed to measure the area of each room of the building and divide this area over the occupant load factor. Then, a sum of all rooms occupant load to generate the total occupant load of a specific fire zone/ floor/ building. This

APPLYING MACHINE LEARNING TO ENHANCE THE IMPLEMENTATION OF EGYPTIAN FIRE & LIFE SAFETY CODE IN MEGA PROJECTS

process usually takes roughly three to four days. Having said that, if there are several projects are running in tandem, there might be a problem related to time management and accuracy as well. Hence, a new tool is done to notably shrink the time taken to finalize this task from 3-4 days to 2 minutes.

1.2 OBJECTIVES

This research aims to develop an automated workflow for rooms' Occupant Loads calculation according to The Egyptian Code or any other code for the fundamentals of design and implementation requirements for the protection of building (Fire Code) to identify a clear understanding of BIM and machine learning, and explore the capabilities of data mining and create datasets related to classification for fire codes.

2. Machine Learning

Machine learning is a type of artificial intelligence that enables a system to learn from data as a training set from past experiences (Judith Hurwitz, 2018). Then, build a mathematical model based on algorithms that can improve, describe data, and predict outcomes. And well-developed ML model can predict or decide based on large given training sets and more applied testing sets. (Catarina Belém, 2019)

3. Machine Learning Types

3.1 SUPERVISED MACHINE LEARNING

An artificial system is created that can learn the mapping between the input and the output. and can predict the output from new inputs. If the outputs of dataset are from class label it leads to classification technique and if the outputs are from continuous values it leads to regression of the inputs. The relationship between the inputs and outputs information is represented with learning model parameters. When these parameters are not directly available from training samples, a learning system can estimate these parameters. (Qiong Liu, 2012)

3.2 UNSUPERVISED MACHINE LEARNING

It is a methodology where the model is working on its own to determine patterns and information that was previously undetected instead of supervising the model. It is mainly used to extract conclusions from large datasets

consisting of unlabeled data to classify the output based on pattern or cluster (groups) to determine the outputs. (Aized Amin Soofi, 2017)

3.3 SEMI-SUPERVISED MACHINE LEARNING

The model is created based on classified and unclassified data. The given data has a few labeled data and plenty of unlabeled data. The aim of semi-supervised classification is to build a model that can predict outputs better than that from the model generated by using the labeled data alone. (Mohssen M. Z. E. Mohammed, 2017)

3.4 REINFORCEMENT MACHINE LEARNING

Reinforcement learning (RL) is an area of machine learning concerned with how smart agents should take actions. It is a method to produce intelligent programs called agents by collecting the observed data from the interactions with environment based on actions that would maximize the reward or minimize the risk. (Mohssen M. Z. E. Mohammed, 2017)

4. Data mining

Data mining is a process of knowledge discovery by extracting data and analyzing its pattern based on logical process to make certain decisions. (Ramageri, 2010)

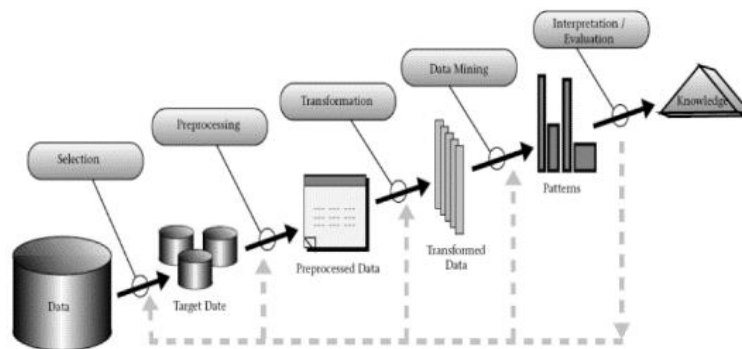

Figure 1: Knowledge discovery Process (Ramageri, 2010)

4.1 CLASSIFICATION TECHNIQUES

To classify large data of records, classification is the most used technique in data mining by analysing data with algorithms. The accuracy of classifier should be acceptable after applying it on test data. (Ramageri, 2010)

APPLYING MACHINE LEARNING TO ENHANCE THE IMPLEMENTATION OF EGYPTIAN FIRE & LIFE SAFETY CODE IN MEGA PROJECTS

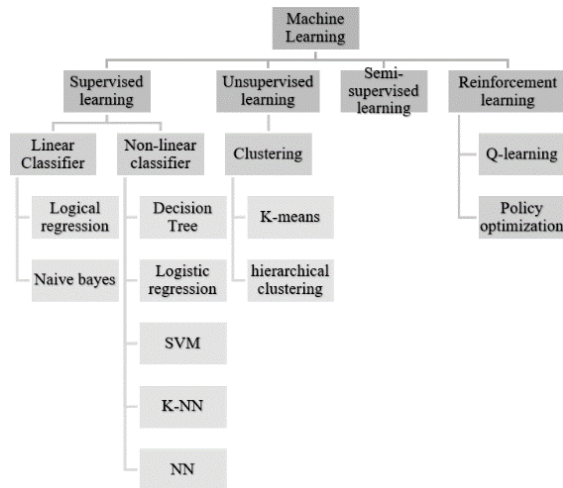

Figure 2: Taxonomy of machine learning algorithms (Muhamedyev, 2015)

4.1.1 Decision Tree (DT)

It consists of a decision tree generated to classify instances at the root node and sorted based on their feature values (S. B. Kotsiantis, 2007). Test nodes is the nodes with outgoing edges, and all other nodes are decision nodes (leaves). Each test node can split the spaces into more subspaces based on used function to predict a new instance. (Ramageri, 2010)

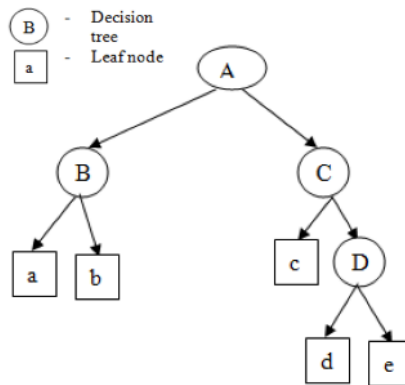

Figure 3: Decision tree model (Ramageri, 2010)

5. Machine Learning Cycle

Creating machine learning model is a cycle process that need to identify first the problem, then collect all useful data and information about the issue,

prepare the data and clean inaccurate data, explore the data then start to identify the pattern to select best prediction tool, train the algorithm with cleaned data, then start to deploy ML model and evaluate the model with test data set and assess the prediction output that require precision, accuracy and minimum error. (Akinsola, 2017)

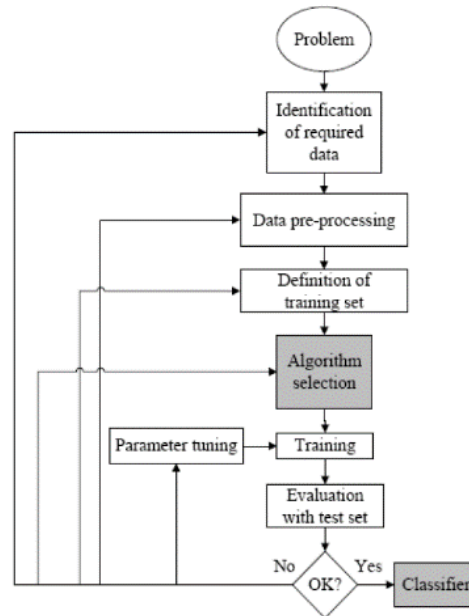

Figure 4: The Processes of Supervised Machine Learning (Akinsola, 2017)

5.1 DATA PRE-PROCESSING

It plays a main role in text mining techniques. it is the first step in the process that starts with cleaning up the data.

5.1.1 Tokenization

It is the method to break the sentence to individual words with removing spaces, commas, symbols (Gohil, 2015)

5.1.2 Filtering

It is the method to remove stop words from text to make the analysis process much easier. These common words that does not give meaning and not used as keyword for analysis like prepositions and pro-nouns, etc. for example: the, in, a, an, with, etc. . (Mohan, 2015)

5.1.3 Stemming

This method is used to identify the root/stem of a word. The aim of the method to reduce the number of words by removing suffixes to get accurate matching and save time and memory space. (Mohan, 2015)

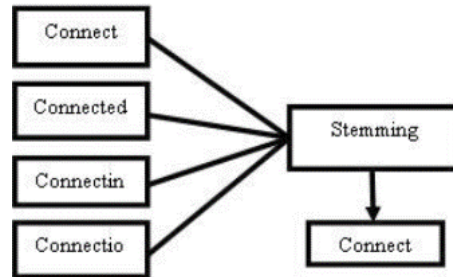

Figure 5: Stemming Process (Mohan, 2015)

5.2 EVALUATION

5.2.1 Accuracy

It is the method that evaluates the machine learning model by calculating the total number of correct predications made over the total predictions. where, TP/TN = True Positives/Negatives, FP/FN = False Positives/Negatives. (Sharma, 2000)

$$Accuracy = \frac{TP + TN}{TP + TN + FP + FN} \quad (1)$$

5.2.2 Precision

It is defined as the correctly predicted classifications over the total predicted classifications. High precision relates to the model's low error in classifying the data. (Sharma, 2000)

$$Precision = TP / (TP + FP) \quad (2)$$

5.2.3 Recall

It is defined as the correctly predicted classifications over all the classifications of members of a certain class. The model gives the information as to how many objects that belong to the class in question get non-classified or get classified outside that class. (Sharma, 2000)

$$Recall = TP / (TP + FN) \quad (3)$$

5.2.4 F1-Score

It essentially brings in both the False Positives and False Negatives to weigh in the error in decision making. It can be declared as the mean value between precision and recall. (Sharma, 2000)

$$\frac{1}{F1\ Score} = \frac{1}{Precision} + \frac{1}{Recall} \quad (4)$$

$$F1_Score = \frac{2 * Precision * Recall}{Precision + Recall}$$

6. Application & Case Study

6.1 APPLICATION

A machine learning model and application (FiRaa) is created as a Revit add-in with C# language, python and Revit API (Application Programming Interface) based on text mining algorithm which applies fire codes on BIM models. It can be adjusted by adding more fire codes to be applied and more datasets can be added for better classifications. The source code is available on (<https://github.com/mohamedalbassel/FiRaa>).

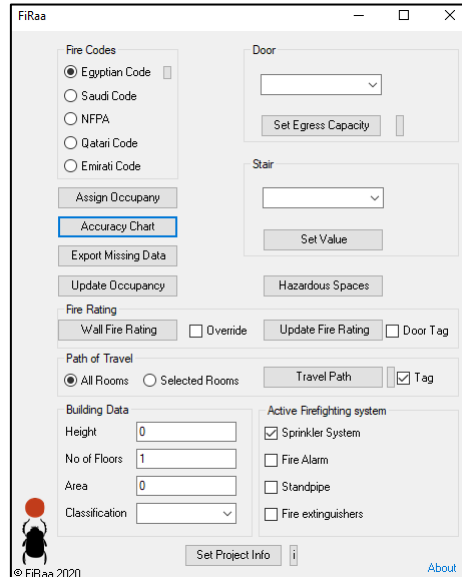

Figure 6: FiRaa application interface (Author)

The below figure is an illustration for the whole process of machine learning model started from defining the problem then collecting data until deploying and validation.

APPLYING MACHINE LEARNING TO ENHANCE THE IMPLEMENTATION OF EGYPTIAN FIRE & LIFE SAFETY CODE IN MEGA PROJECTS

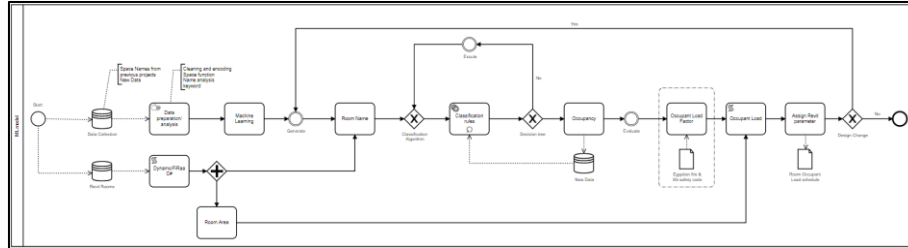

Figure 7: Machine learning model workflow (Author)

6.2 MAGDI YACOUB HOSPITAL

Magdi Yacoub Global Heart Centre is located in the city of October 6, on a piece of land with an area of 150,000 m². The project occupies an area of 110,000 m² and the rest of the land is dedicated to future expansion. The project consists of: Hospital building, Generator and Power Stations Building, Surface parking, Underground fuel storage tank, 5 security rooms, liquid oxygen tanks, Underground rainwater tank.

6.2.1 Applied codes and regulations

The applied codes in this project are the Egyptian fire code (Fundamentals of Design and Requirements, System Requirements, fire detection and alarm systems, Fire Fighting systems) and NFPA (National Fire Protection Association) in addition to Civil Defense instructions.

6.2.2 Classification of occupancy

Structures or portions of structures shall be classified with respect to occupancy in one or more of the groups listed below. A room or space that is intended to be occupied at different times for different purposes shall comply with all of the requirements that are applicable to each of the purposes for which the room or space will be occupied.

The predominant occupancy in hospital building is “health care” group (I-2) and some incidental spaces as per below sketch. (dar alhandasah, 2020)

Machine learning model initiated with collecting all data for classification from previous projects and trained the model according to room names extracted from Revit files, then room names are categorized based on classification. The second step is data preprocessing and cleaning data with splitting the words and stemming method to identify the root of the word.

TABLE 1. Building classifications as per Egyptian Fire Code

Assembly	اشغالالت التجمعات	أ	A	A-1	theatres and Cinemas
				A-2	schools/faculties/court halls/lecture halls/worship houses
				A-3	Closed halls such as gym/swimming pool halls
				A-4	open halls such as Stadiums
Institutional	الاشغالالت المؤسسية	ب	I	I-1	Detention/ spaces for people with mental issues under restrictions
				I-2	Healthcare
Residential	الاشغالالت السكنية	ج	R	R-1	Private Residential units/ villas/ small hotels for less than 25 p.
				R-2	hotels/dorms/solidarity for more than 25 p.
Business	الاشغالالت الادارية	د	B	B	business spaces/ offices/ banks
Mercantile	الاشغالالت التجارية	هـ	M	M-1	areas more than 3000 m2 or more than 3 floors
				M-2	areas between 300 and 3000 m2 with more than 1 floor and less than 3 floors
				M-3	area is less than 300 m2 with only ground floor
Industrial	الاشغالالت الصناعية	و	F	F-1	high hazard storages
				F-2	Medium hazard such as helipads/ print shops/ labs/substations/car services/cold storages
				F-3	Low hazard such as parking and workshops and storages

TABLE 2. Data collection and preprocessing from previous projects (dar alhandasah, 2020)

Project Name	Project Part	Building Type	Room numbers	ML Accuracy percentage	Model train	Run Time	Traditional way
Magdi Yakoub		Hospital	2466	60%	Data preprocessing/analysis	3days	3days
				100%	add missing to achieve 100% accuracy	2hr	
NGHA	tower 2-5	Hospital	758	92%	add missing to achieve 100% accuracy	0.5hr	3days
	tower 6-10		993	99.80%	add missing to achieve 100% accuracy	0.25hr	
	GF		854	98.20%	add missing to achieve 100% accuracy	0.25hr	
ABE		Office	521	73%	add missing to achieve 100% accuracy	0.25hr	1day
Elkhafgi		Office	321	81%	add missing to achieve 100% accuracy	0.25hr	1day
TMG		Office	457	94%	add missing to achieve 100% accuracy	1 min	1day

After data preprocessing, the training set is defined, and the classifier is built based on decision tree algorithm using C# and python. To elaborate, the algorithm is looping in each room name in BIM model, and if the room name is in training set, it is converted to occupant load classification in each branch from decision tree and if the name is not in this branch then it starts to search in the other branches. This algorithm could be done in dynamo and python

APPLYING MACHINE LEARNING TO ENHANCE THE IMPLEMENTATION OF EGYPTIAN FIRE & LIFE SAFETY CODE IN MEGA PROJECTS

code as open source so it can be adjusted to add the missing and new data, and more fire codes.

6.2.3 Occupant load factors

In determining means of egress requirements, the number of occupants for whom means of egress facilities are provided shall be determined. To explain, to calculate the total occupant load for a certain building, it is needed to determine the occupant load for each space/room in the building. The cumulative occupant load of all rooms/spaces equals the total building room (SBC801, 2018). Hence, the occupant load of each room/space is based on the main function of it. (NFPA101, 2018)

$$Occupant\ Load\ (x) = \frac{Area\ (x)}{Occupant\ Load\ Factor\ (x)} \tag{5}$$

Where x the space/room, and all the factors is are related to the data of this space/room. To illustrate, the area (x) is space/room area. And the Occupant Load Factor (x) is the factor intended for the function of the space. Moreover, to calculate the cumulative occupant load for all the building, it is needed to follow the following the below equation:

$$Building\ Occupant\ Load = \sum^n Occupant\ Load\ (X_n) \tag{6}$$

The occupant load factors are determined based on the table below according to Egyptian code. (Egyptian Fire Code, 2007)

TABLE 3. Occupant load factors

Use / Space	Occupant load factor(m2/person)
Patient room/ ICU/Operation/Surgery	10
Residential	2/bedroom
Cafeteria	1.2
Office	10
Kitchen	10
Storage	50
MEP	5
Parking	30
Prayer	0.65

After classification, a dictionary is created in the application to look up and assign the occupant load factor according to fire code. Then calculate the occupancy by extracting all room areas and divide it on occupant load factor then assign occupancy to each room.

6.2.4 Validation & Accuracy

After applying the model on many projects, we need to evaluate the model and extract the missing data then calculate the model accuracy using (Accuracy chart) and (Export Missing Data) buttons as below figures. The following figure show the missing data as a list in the model and also, the second column is for spelling check to highlight the errors and suggest a correct name for rooms. Then we have a button to export the missing data to be added to the ML model and send an email to author.

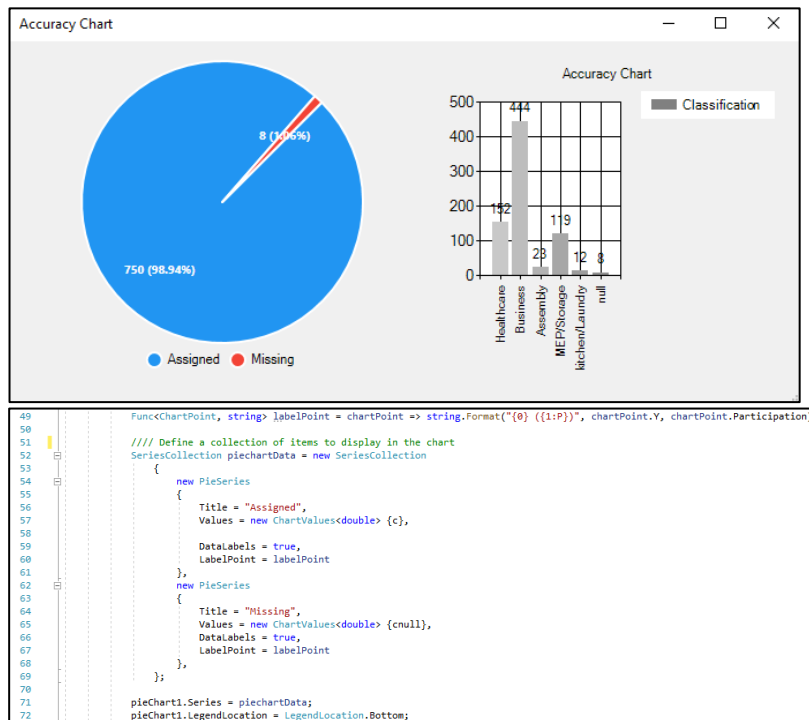

Figure 8: Accuracy chart and corresponding code (Author)

6.2.5 Protection of construction elements

For any building, in any Fire and Life Safety Codes, the type of construction is determined based on the same criteria. In other words, there are five factors have influence on the type of construction and the required level of protection. The factors are Building Classification, Building Height, Building Area, Number of levels in the building, and whether the building is equipped throughout with Automatic Sprinkler system or not. the below figure is considered as a sample from the NFPA 5000 Code. According, every type of construction is translated to a particular fire protection level. (NFPA5000, 2018).

APPLYING MACHINE LEARNING TO ENHANCE THE IMPLEMENTATION OF EGYPTIAN FIRE & LIFE SAFETY CODE IN MEGA PROJECTS

Hospital Building: According to Egyptian fire protection code part no. 1, table no. 6.2.2.1.b titled “Allowable Building Height, Area, no. of public ways around the building and Fire Resistance Ratings for structural elements require a minimum of 2 hr. fire rated construction. Generators and power stations: According to Egyptian fire protection code part no. 1, table no. 6.2.2.1.b titled “Allowable Building Height, Area, no. of public ways around the building and Fire Resistance Ratings for structural elements require a minimum of 1 hr. fire rated construction.

Project info method is to identify the type of building through the building data (height, number of floors, area, classification) and the active firefighting system (sprinkler system, fire alarm, standpipe, fire extinguishers) based on decision technique and assign it in Revit parameter.

6.2.6 Egress capacity by Egyptian Code Methodology

The Egyptian Code defines exit width in terms of the number of ‘exit units’ required for a given occupant load. An exit unit is defined by table 4-2-3-1 as ‘the width which allows a single person to pass’ and is given a value of 550mm. The exit unit capacity for a given exit is dependent upon the occupancy classification of the building. (Egyptian Fire Code, 2007)

TABLE 4. Egress capacity by Egyptian Code (Egyptian Fire Code, 2007)

Occupancy	Type of Exit	Exit Unit Capacity (No. of persons)	
		Ground Floor	Above/ Below Ground Floor
Assembly (A-3) & Mercantile (H)	Corridor	90	60
	Staircase	N/A	60
	Door	110	75
Healthcare (I)	Cor.& St.	30	
	Doors	36*	
Residential (R)	Cor.& St.	30	
	Doors	45	
Industrial (F-1)	Cor.& St.	30	
	Door	45	

Door openings in means of egress need to be not less than 900mm in clear width for exit door and 800mm for access door. Any door in a means of egress is side-hinged or pivoted-swinging and swings to the full required width of the opening. Door leaf swings in the direction of egress. Doors are readily open from the egress side whenever the building is occupied.

FiRaa can automatically assign fire barrier rating for walls and doors by extracting data from rooms after classification to wall boundaries then doors, after that it can draw the crystal lines that represent the hours of fire rating or color it with Revit filter.

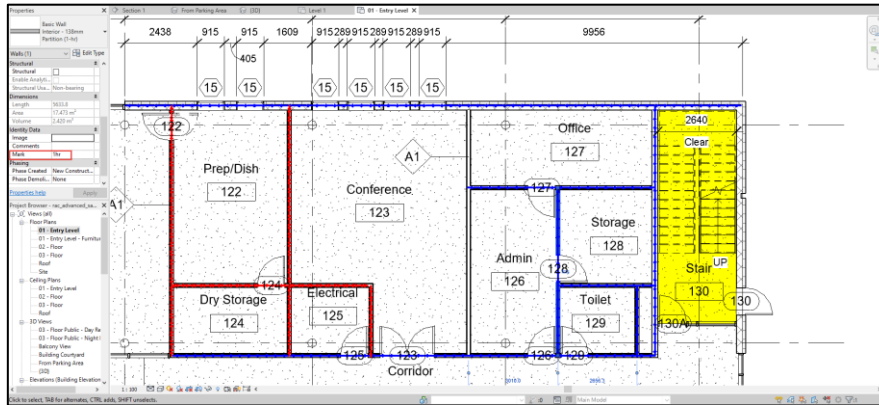

Figure 9. Modeling crystal lines for wall fire rating in Revit using FiRaa

6.2.7 Path of travel

Every corridor provides access to not less than 2 approved exits without passing through any intervening rooms or spaces other than corridors and lobbies. Where 2 exits, exit accesses, or exit discharges are required they are located at a distance from one another not less than 1/2 the length of the maximum overall diagonal dimension of the building or area to be served. Travel distance and Dead-end corridors are arranged in order not to exceed the relevant distances.

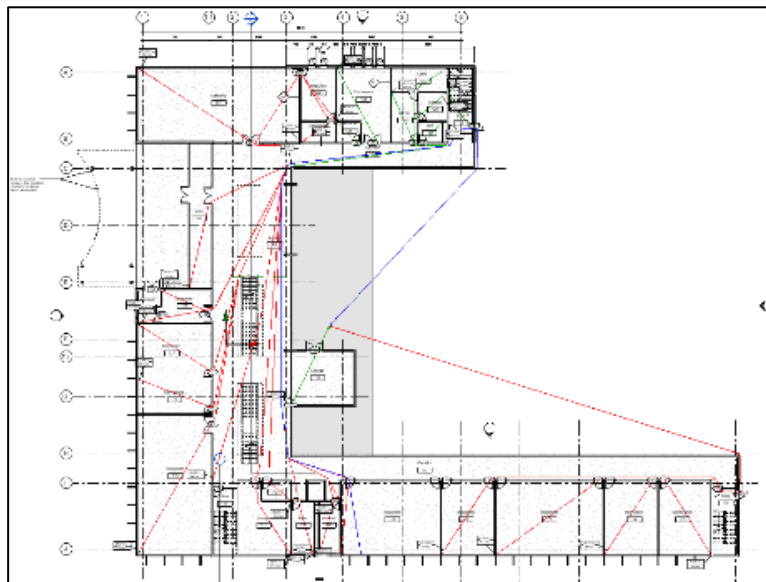

Figure 10: Modeling path of travel in Revit using application on Autodesk sample project

APPLYING MACHINE LEARNING TO ENHANCE THE IMPLEMENTATION OF EGYPTIAN FIRE & LIFE SAFETY CODE IN MEGA PROJECTS

The travel path is a tool in the application to draw the lines in Revit to validate the shortest path from specified access point and all rooms in the floor and then highlight the paths in red that exceed the mentioned distance in fire code and highlight the longest path in blue from all rooms to access point. also, it can tag the lines in Revit for documentation.

7. Conclusions

This research is a demonstration for an automated workflow for classification based on machine learning and decision tree technique. In other words, an application with datasets is created for fire codes implementation on BIM models. Building Information Modeling (BIM) and machine learning (ML) adoption increase building performance by predicting the outcomes and increase working productivity. In addition, it shrinks the time wasted on the traditional Fire and life safety process of the production and analysis of a certain project. Moreover, it reduces cost by decreasing the needed number of man hours for a certain project. Accordingly, it increases the profitability of construction projects. Machine learning model needs to consider the collected training datasets, and the model needs to be scalable to enable the classifier to make correct predictions and increase accuracy and precision.

8. Recommendations

- According to the research, it is paramount to follow a pedagogy to improve the academic curriculum to involve machine learning awareness in architecture, additionally, build an experience of ML and algorithmic thinking in educational sectors.
- There is a need for further research about using virtual reality in evacuation studies to simulate the egress of people.
- Reinforcement learning, unsupervised machine learning, generative design, digital twin and internet of things (IoT) in architecture need further research to solve problems with optimum solution.
- Users need to follow naming convention for room names to be consistent to facilitate ML model training.
- Users ought to be vigilant for the code and regulations of the country where the project will be constructed.

References

- Aized Amin Soofi, A. A. (2017). Classification Techniques in Machine Learning: Applications and Issues. *Journal of Basic & Applied Sciences*, 2017, 13, 459-465.
- Akinsola, J. E. (2017). Supervised Machine Learning Algorithms: Classification and Comparison. *International Journal of Computer Trends and Technology (IJCTT)*.
- Catarina Belém, L. S. (2019). On the Impact of Machine Learning, Architecture without Architects? *CAAD Futures* .
- dar alhandasah. (2020). Retrieved from <https://www.dar.com/>
- Egyptian Fire Code. (2007). *Egyptian Code for Fundamentals of Design and Requirements for Building's Firefighting*. cairo: Ministry of housing, utilities & urban communities.
- Gangavarapu, T. (2020). *Applicability of machine learning in spam and phishing email filtering: review and approaches*. Springer Nature B.V.
- Gohil, L. (2015). Text Mining: Process and Techniques. *International Journal of Innovative Research in Computer Science & Technology*.
- Huisman, D. O. (2015). To What Extent do Predictive, Descriptive and Prescriptive Supply Chain Analytics Affect Organizational Performance. *5th IBA Bachelor Thesis Conference, University of Twente*.
- Judith Hurwitz, D. K. (2018). *Machine Learning For Dummies, IBM Limited Edition*. Hoboken, NJ: John Wiley & Sons, Inc.
- Maya Sappelli, M. H. (2017). A Vision on Prescriptive Analytics. *The Third International Conference on Big Data, Small Data, Linked Data and Open Data*.
- Mohan, V. (2015). Preprocessing Techniques for Text Mining - An Overview. *International Journal of Computer Science & Communication Networks*.
- Mohssen M. Z. E. Mohammed, E. B. (2017). *Machine Learning: Algorithms and Applications*. Taylor & Francis Group, LLC.
- Muhamedyev, R. I. (2015). Machine learning methods: An overview. *COMPUTER MODELLING & NEW TECHNOLOGIES*.
- Nasteski, V. (2017). An overview of the supervised machine learning methods. *DOI 10.20544/HORIZONS.B.04.1.17.P05*.
- NFPA101. (2018). *Life safety Code*. NATIONAL FIRE PROTECTION ASSOCIATION.
- NFPA5000. (2018). *Building Construction and Safety Code*. NATIONAL FIRE PROTECTION ASSOCIATION.
- Qiong Liu, Y. W. (2012). SUPERVISED LEARNING. *DOI: 10.1007/978-1-4419-1428-6_451*.
- Ramageri, B. M. (2010). DATA MINING TECHNIQUES AND APPLICATIONS. *Indian Journal of Computer Science and Engineering*.
- S. B. Kotsiantis, I. D. (2007). Machine learning: a review of classification and combining techniques. *Springer Science+Business Media*.
- S. Poornima, M. P. (2020). A survey on various applications of prescriptive analytics. *International Journal of Intelligent Networks*.
- SBC801. (2018). *Saudi Fire Code*. Saudi Building Code National commite.
- Sharma, V. (2000). Survey of Classification Algorithms and Various Model Selection Methods. *Journal of Machine Learning Research*.
- Viswanath Pulabaigari, H. S. (2011). An Improvement to k-Nearest Neighbor Classifier. *IEEE International Conference on Recent Advances in Intelligent Computational Systems* .

BRIEFING AI

From Architectural Design Brief Texts to Architectural Design Sketches

LALE BAŞARIR, KUTLUHAN EROL
Izmir University of Economics, Izmir, Turkey
lale.basarir@ieu.edu.tr
kutluhan.erol@ieu.edu.tr

Abstract. The main focus of this research is to uncover the underlying intuitive knowledge of architecture with the help of machine learning models. To achieve this, a generic architectural design process is considered and divided into iterative portions based on their output for each phase. This study looks into the initial portion of the architectural design process called “*Briefing*”. The authors search for the intuition that exists within the design process and how it can be learned by artificial intelligence (AI) that is currently gained through master-apprentice relationship and experience that builds up this knowledge. In this study, a way to enable users to attain an architectural design sketch while defining an architectural design problem with text is explored. This on-going research decomposes the components of the briefing and preliminary design sketching processes. Therefore the domain knowledge at each phase is considered for translating to constraints via natural language processing (NLP) and machine learning (ML) models such as Generative Adversarial Networks (GANs).

Keywords: *Architectural design brief, artificial intelligence, machine learning, natural language processing, CGANs.*

ملخص. ينصب التركيز الرئيسي لهذا البحث على الكشف عن المعرفة البديهية الأساسية للهندسة المعمارية بمساعدة نماذج التعلم الآلي. لتحقيق ذلك، يتم النظر في عملية التصميم المعماري العامة وتنقسم إلى أجزاء تكرارية بناءً على مخرجاتها لكل مرحلة. تبحث هذه الدراسة في الجزء الأول من عملية التصميم المعماري المسمى "موجز". يبحث المؤلفون عن الحدس الموجود في عملية التصميم وكيف يمكن تعلمه من خلال الذكاء الاصطناعي (AI) الذي يتم اكتسابه حاليًا من خلال العلاقة بين المعلم والمتدرب والخبرة التي تبني هذه المعرفة. في هذه الدراسة، تم استكشاف طريقة لتمكين المستخدمين من الحصول على

رسم تخطيطي للتصميم المعماري أثناء تحديد مشكلة التصميم المعماري مع النص. يفصل هذا البحث المستمر مكونات عمليات الإحاطة والتصميم الأولي للرسم. لذلك يتم النظر في معرفة المجال في كل مرحلة للترجمة إلى قيود عبر معالجة اللغة الطبيعية (NLP) ونماذج التعلم الآلي (ML) مثل شبكات الخصومة التوليدية (GANs).

الكلمات المفتاحية: موجز التصميم المعماري ، الذكاء الاصطناعي ، التعلم الآلي ، معالجة اللغة الطبيعية ، شبكات CGAN

1. Introduction

Architectural design is a solution response to a defined spatial need. Design decisions starting from briefing of the design problem to construction phase of built environment involve many stakeholders such as clients, occupants, architects, engineers, constructors including as well as developers and contractors etc. The diversity of expertise and decision making authorities puts the architect into a role of a participant rather than a leader. Therefore the preliminary design phase is the one that the architect is the lead decision maker and/or the main expert (Akin, 1987). The preliminary design phase is where the spatial need is defined. The *defined spatial need* is the problem that the architect is *expected to solve*. Therefore the problem should be defined in a very elaborate way so that the solution options become as clear as possible. Ill-defined problems are solved at the expense of time and budget while causing dissatisfaction both for clients and occupants.

Architects' response to design problems display the presence of a design methodology. However, design processes cannot solely be explained by an explicit procedure that can be taught to a next generation. Eastman calls the remaining procedure of the design process as *intuitive design* and defines it as the antithesis of a *design methodology*. (Eastman, 1970) The intuition underlying the design process makes it hard to "teach or instruct" within a methodology however the authors are searching how it would help to invert the process and ask how it can be "learned" through master-apprentice interaction where AI is the apprentice and data is the master.

This study suggests the construction of a representational framework to serve as a template for the definition of an architectural design problem (figure 1). The proposed framework takes the client's speech or textual description of the design problem commonly known as "the brief" and works on generating corresponding images depicting visual versions of attributes that are briefed.

BRIEFING AI: FROM ARCHITECTURAL DESIGN BRIEF TEXTS TO ARCHITECTURAL DESIGN SKETCHES

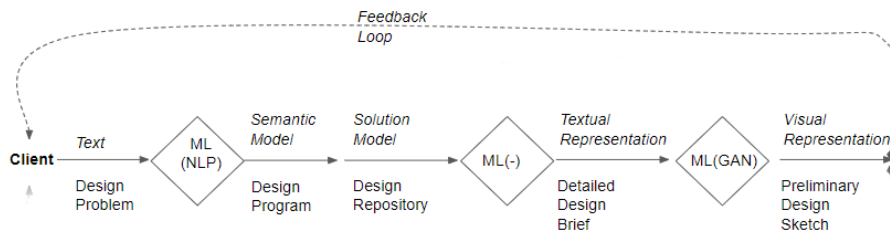

Figure 1. A high-level representational framework for briefing AI

2. The Brief as a Launchpad for Design

Design processes has been analyzed innumerous times and from a wide range of standpoints (Akin and Lin, 1995; Oxman, 1995; Gero and Tang, 2001). Therefore, the authors keep the one that they anticipate as the closest definition to lay a clear ground for this research which is: “The translation of information in the form of requirements, constraints and experience into potential solutions, which are considered by the designer to meet required performance characteristics.” Luckman (1967) Phases of design reveal a list containing *analysis*, *synthesis* and *evaluation* on which researchers come to a consensus. Adding to this list, the feedback loop that holds the iterative cycle of design involves *simulation* and *decision* steps (Bogers et. al, 2008). Being the launchpad for design the briefing process needs optimum perfection.

2.1. PROBLEMS CONCERNING BRIEFS

This feedback loop starts with the briefing phase. It is a critical phase for the architect. Therefore the architects expect a proper structure as well as a clear understanding of what the client really wants. A major concern however, is making sure that the client can express their architectural ambitions. Words are not explicit enough to define the spatial needs. The use of images helps this process while facilitating a clearer definition of the problem space and avoiding misunderstanding due to varying personal associations. Sketching process is also considered to employ interactive imagery, along with reasoning of visual analogy from a database of vision built by the designer through experience. (Goldschmidt, 1995)

Another debate concerning the briefing phase is that it may either be finalized before the design phase starts or the brief may evolve throughout the

design process. The latter however is usually the case that also involves the iterative cycle that is fed into the design process. Although the entire definition of the design problem is beneficial for best solutions there is a portion of the initial intent left untold or unidentified due to the nature of communication. This is rooted in handling of the problem changing from one person to the other or from the client to the expert that is the architect in this case. Priorities may clash for example and problem definitions may need iterative refinements. The intuition and experience of the expert would reveal clashes of interest when the design intent is expressed. However, as mentioned earlier this is an exhausting process that is usually left to imperfection for the sake of time constraints and the problem is left ill-defined.

3. The Proposed Framework

Automation may help define the design problem however that solution requires all the expert knowledge along with the clients design intent sorted and implemented into the process.

Auto-generation of design sketches from text is still a far-fetched goal with the current capabilities and skills we have in both domains of architecture and AI. However, deep convolutional networks (CNNs) have recently helped facilitate text representations trained on characters and words efficiently (Zhang and LeCun, 2015; Kim, 2014).

The proposed framework takes the client's speech or textual description of the design problem commonly known as "the brief" and works on generating corresponding images depicting visual versions of attributes that are briefed. The proposed AI is expected to output architectural sketches involving spatial relationships. The spatial relationship is expected to cover both geometric and topological relations. However, this relationship is not embedded as in an expert system or a parametric database within a generative design system. Rather, a learning model based on semantic analysis and visual pattern recognition is suggested

3.1. RELATED WORK

Creating word embedding is the initial step to reach an efficient representation for text in order to create a semantic model. Embedding is a vector for representation of words in a sentence (Reed et.al, 2016). Word2Vec is an efficient method for constructing an embedding involving two neural networks (NN) models called Common Bag of Words (CBOW) and Skip Gram for assigning conceptual links(URL 1). Generative Adversarial Networks GANs are models that are proposed for this framework. (Goodfellow, 2014) The discriminator is given a real image and it gives an output, and then it is given a fake image and it rolls out a decision as a

BRIEFING AI: FROM ARCHITECTURAL DESIGN BRIEF TEXTS TO ARCHITECTURAL DESIGN SKETCHES

classifier. While the discriminator gets trained on determining whether the generated image is fake or real the generator also learns to create better convincing images to show to the discriminator. Therefore both parties force each other to improve. However, this improvement is not the result of an explicit set of rules and values. Text2image is a Conditional GAN (CGAN) model made up of two stages (Zhang, H., et.al, 2017). Stage 1 Generator reads a sentence as an input and puts out a primitive low resolution image (64X64). The Stage 2 Generator receives the original sentence as input along with the low resolution image and outputs a higher resolution image (256X256) GANs, Word2Vec, and Text2Image method are used in the implementation of this framework.

Another related work is an automated brief builder set for a similar research problem. Brief builder (URL2) provides all parties with a tool to define and clarify clients' needs and keep track of the design process. There are several work automating brief building however, the authors are mainly interested in how the architects interpret clients' needs.

4. Implementation

The proposed model aims to develop a notion/understanding of what an image of a certain *thing* is thereby extracting the structure of an entity within a latent space. A textual definition of that entity is encoded and fed into the model.

The vectors corresponding to texts help represent a mapping within the latent space where image generation takes place. The semantic model is not set up by a supervisor but is generated as a structure within the deep learning model.

Textual encoding is the initial phase of the framework. The text needs preprocessing before going through a mapping whereby each unique word is assigned an ID with the appropriate code written in python, followed by creating a lookup dictionary. Each time the model is fed with a textual data, it is expected to do the mapping to reach a semantic stage. However, this mapping does not help understanding of the words within a context. Therefore Word2Vec method is used to encode sentences upon translating sentences taken from a brief obtained from a client containing eight items: *1. The building should benefit from natural light as much as possible. Back of the building is facing south. 2. The building should have natural cooling and heating to complement other types of gentle systems. It should also use solar heating. 3. The two units of the building should have independent systems (water, electrical, gas, heating, cooling, solar) but located centrally together in common areas in order to maximize space of each unit. 4. The front of the building (north facing) cannot be modified as it is a historic building protected by the city code. 5. Each unit should have a layout that optimizes for people*

working from home rather than people that are only home to rest and entertain. 6. Noise dampening solutions must be used to minimize transfer of noise from neighboring units and to provide privacy for roommates. 7. Top unit should have a roof deck. 8. Each unit must have four bedrooms, two bathrooms, a kitchen/dining area, a living area. Text is therefore translated into a vector form for encoding. Below is the seventh item written in the form of vectors:

“Top unit should have a roof deck.”

Top = [1,0,0,0,0,0,0] ; unit = [0,1,0,0,0,0,0] ;

should=[0,0,1,0,0,0,0] ; have = [0,0,0,1,0,0,0] ; a = [0,0,0,0,1,0,0] ;

roof = [0,0,0,0,0,1,0] ; deck = [0,0,0,0,0,0,1]

The words are then linked to a context within the network through adjustments by back propagation. The context defined by the image (figure 2) corresponding to the textual description is then linked to the text by the GAN model (figure 3).



Figure 2. Contextual image for “roof deck” for Briefing AI (left) (URL-3),(right) Authors’

For generation of preliminary sketches from textual and auxiliary expressions of intent a 2 stage ML model is proposed. Stage 1 starts with the Φ_t embedding of the given textual description yielded through an encoder (pretrained). Stage 1 generator network generates an image. Generated data looks like the training data in order to get the discriminator to believe that it is the real data. The discriminator outputs a value of either 0 or 1 to declare whether it classifies the image to be real or not. Although this process may look as if it only does classification, it actually refines the generated images through iterations. As the images are generated again and again they are better versions of themselves. This refinement improves the learning process.

BRIEFING AI: FROM ARCHITECTURAL DESIGN BRIEF TEXTS TO ARCHITECTURAL DESIGN SKETCHES

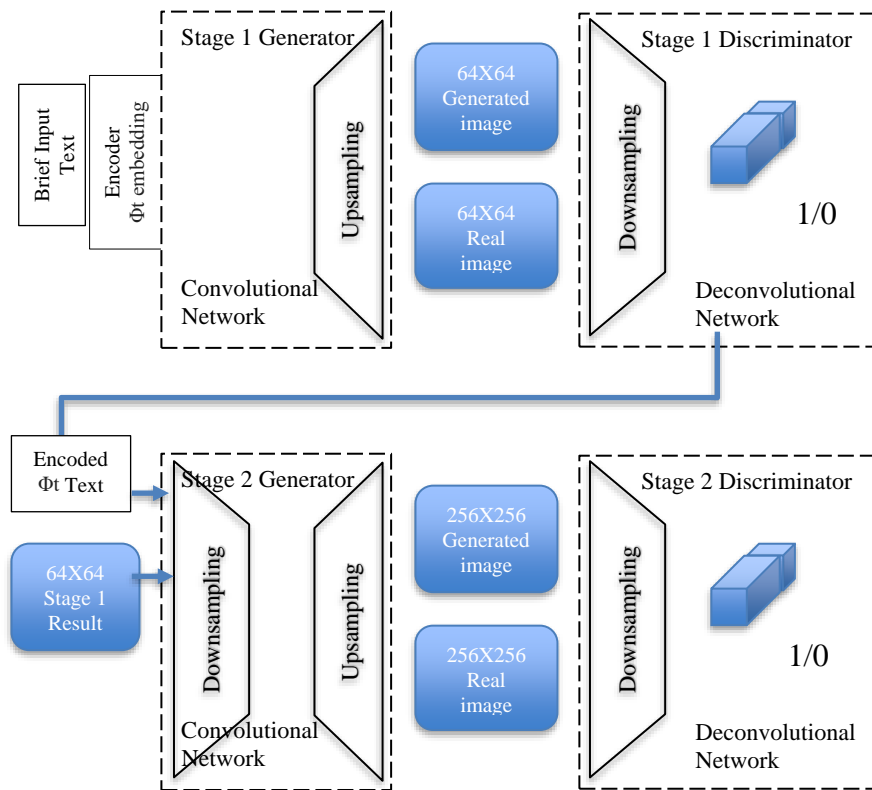

Figure 3. Two-stage GAN model proposed for Briefing AI framework

Therefore, when vectors holding the numerical representations of images change, both the meaning and the images themselves change yielding better versions of text2image outputs.

Data that the model will use has not been specified yet. This has so far been the most challenging aspect of this research. There are options such as COCO, the Cityscapes or the Arcbazar.com platform which is the most appropriate data source (Table 1) for this ongoing research as an architectural dataset that would correspond to the needed image context.

The model is then planned to be evaluated based on topological and geometric relations of spatial design output.

Table 1. The structure of the architectural competition platform as data source.

ARCBAZAR Platform structure		Source	Data
Input	Competition Launch	Information(description, goals, preferences)	Text
		Before Images	Image
		Competition Wall	Text+Image
		Comments	Text
Output	Design Entries	Deliverables	Image (Raster)
			Image (Vector)
		Evaluation	Scores

5. Future Work

This framework proposal displays the inherently ill-defined quality of design briefing and does a scanning of available options of AI models to help refine the problem definition and solution suggestion processes. In order to structure the intended model where it is fed a brief and yields a preliminary sketch we need a dataset with briefs and corresponding images (will be provided by Arcbazar). The work will continue with a problem specification language (PSL) and a solution specification language (SSL) with an iteration space in between. We hope that this study motivates future research on refinement of design briefing stages with a deeper understanding of the problem space that initiates design processes.

6. Conclusion

Would this model correspond to the understanding of briefs as the clients' intent? This framework is being constructed in order to understand the intuition buried in the expertise of the architect active during the preliminary design process. Automation of the briefing process can be possible through computing as previously mentioned. So the research starts with transcription of clients' spoken expression of the design problem into a textual form. This textual data is analyzed to reveal and set up the underlying semantic model representing the "design program" otherwise called "the brief". A style-transfer approach is used. The contribution of the research lies in the effort to uncover domain knowledge and structure the methodological and the intuitive steps that take place within the preliminary architectural design process.

BRIEFING AI: FROM ARCHITECTURAL DESIGN BRIEF TEXTS TO ARCHITECTURAL DESIGN SKETCHES

References

- AKIN, O. and LIN, C., 1995. Design protocol data and novel design decisions. *Design Studies* 16(2), 211-236
- AKIN, O. and Center. CMUEDR, 1987. Expertise of the architect. *Carnegie Mellon University. Pittsburg, PA*. EDRC-48-09-88 .DOI: 10.1184/R1/6075785.v1.
- BOGERS, T., VAN MEEL, J.J. AND VAN DER VOORDT, T.J.M., 2008. "Architects about briefing: Recommendations to improve communication between clients and architects", *Facilities*, 26 (3/4), 109-116.
- GERO J.S. AND TANG, H., 2001. The differences between retrospective and concurrent protocols in revealing the process-oriented aspects of the design process. *Design Studies* 22(3), 283-295
- EASTMAN, C. M., 1970. "On the analysis of intuitive design processes", in *Emerging Methods in Environmental Design and Planning*, Ed. G. T. Moore (MIT Press, Cambridge, Mass.), 21-37.
- GOLDSCHMIDT, G., 1995. Visual displays for design: Imagery, analogy and databases of visual images. In A. Koutamanis, H. Timmermans, I. Vermeulen (eds.). *Visual Databases in Architecture*. Avebury:Aldershot, 53-76.
- GOODFELLOW, I., POUGET-ABADIE, J., MIRZA, M., XU, B., WARDE-FARLEY, D., OZAIR, S., COURVILLE, A., AND BENGIO, Y., 2014. Generative adversarial nets. In *Advances in neural information processing systems*, pp. 2672–2680,
- KIM Y., 2014. Convolutional neural networks for sentence classification. arXiv preprint [arXiv:1408.5882](https://arxiv.org/abs/1408.5882).
- LUCKMAN, J., 1967. An approach to the management of design. *Operational Research Quarterly* 18(4), 345–358.
- OXMAN, R. 1995. 'The reflective eye: Visual reasoning in design' in A. Koutamanis, H. Timmermans, I. Vermeulen (eds.), *Visual Databases in Architecture*, Avebury : Aldershot, 89-112.
- REED, S., AKATA, Z., YAN, X., LOGESWARAN, L., SCHIELE, and LEE, H., 2016. Generative adversarial text-to-image synthesis. *ICML, 33 rd International Conference on Machine Learning*, New York, NY, USA
- VAN DER VOORDT, D.J.M. AND VAN WEGEN, H.B.R., 2005. *Architecture in Use, An Introduction to the Programming, Design and Evaluation of Buildings*, *Architectural Press*, Oxford.
- ZHANG, H., TAO X. AND HONGSHENG L..ZHANG, S., XIAOGANG, W., HUANG, X., DIMITRIS, M. 2017. "StackGAN: Text to Photo-Realistic Image Synthesis with Stacked Generative Adversarial Networks." *2017 IEEE International Conference on Computer Vision (ICCV)* : 5908-5916
- ZHANG X, LECUN Y., 2015. Text understanding from scratch. arXiv preprint [arXiv:1502.01710](https://arxiv.org/abs/1502.01710).
- URL-1 <https://towardsdatascience.com/introduction-to-word-embedding-and-word2vec-652d0c2060fa>
- URL-2 <https://www.briefbuilder.com/#features>
- URL-3 <https://www.allhomes.com.au/news/rooftop-deck-and-lap-pool-draw-cards-for-new-build-in-coombs-810889/>

UTILIZING BEHAVIORAL AGENT-BASED MODELING IN AN AUTOMATED INTEGRATIVE DESIGN PROCESS

MAZIAR HEYDARI, MOHAMMAD JAVAD MAHDAVINEJAD
Tarbiat Modares University, Tehran
maziiarh@gmail.com
mahdavinejad@modares.ac.ir

AND

KHOSRO DANESHJOO
Khdaneshjoo@modares.ac.ir

Abstract. Developing shift in architectural practice from previously exercised to late computational methods struggles to harmonize the concentration and consolidation between physical and humane aspects of a project or even the very thinking mechanism itself. Integrating Design workflow with the emerging simulation environment of agent-based modeling (ABM) in the complex architectural process can help us formulate a non-linear method. In this method, various complex design aspects such as humans' socio-behavioral attributes and structural complexities can be utilized to render an evolving design profile. Employing ABM in the design process enables us to evaluate complex problems using node-based tools to generate complicated simulation and exercise an adequate approach.

Keywords: *Parametric Design; Agent-based design; Integrated design; Performative architecture; responsive shade.*

ملخص. إن تطوير التحول في الممارسة المعمارية من الأساليب الحسابية التي كانت تمارس سابقاً إلى الأساليب الحسابية المتأخرة يكافح من أجل موازنة التركيز والتوحيد بين الجوانب المادية والإنسانية للمشروع أو حتى آلية التفكير نفسها. يمكن أن يساعدنا دمج سير عمل التصميم مع بيئة المحاكاة الناشئة للنمذجة القائمة على الوكيل (ABM) في العملية المعمارية المعقدة في صياغة طريقة غير خطية. في هذه الطريقة ، يمكن استخدام العديد من جوانب التصميم المعقدة مثل السمات الاجتماعية والسلوكية للبشر والتعقيدات الهيكلية لتقديم ملف تعريف تصميم متطور. يتيح لنا استخدام ABM في عملية التصميم تقييم المشكلات المعقدة باستخدام الأدوات القائمة على العقد لإنشاء محاكاة معقدة وممارسة نهج مناسب.

UTILIZING BEHAVIORAL AGENT-BASED MODELING IN AN AUTOMATED INTEGRATIVE DESIGN PROCESS

*الكلمات المفتاحية: تصميم حدودي؛ تصميم قائم على الوكيل؛ تصميم متكامل؛ العمارة الأداثية،
تظليل سريع الاستجابة.*

1. Introduction

If architecture is supposed to answer human and human needs, it should understand the user, environment, and ongoing changes; therefore, behavioral elements weigh on design parameters in a parallel procedure. Using agent-based simulations allows us to assign the user's actions to a virtual component called the agent to achieve this effect, ensuring that the behavior simulation is embedded within the conceptual design workflow. Therefore a methodological approach needed to inlay suggested element in the computational design body on which this research is focused, and for this matter, we need to:

- Understand ABM and understand how we can employ ABM simulation's data in an integrated design process.
- Create a methodological framework.

First, we will represent an overview of ABM and integrated architecture. Then, the simulation environment will be studied, and lastly, the method used to integrate these factors to address the two points mentioned before.

In previous studies, ABM was used in the early stages of the design process as a simulation tool to get the design aspect closer to its goals. In Deniz Kiraz & Kocaturk's study in 2019, ABM was used in the planning stage of design to maximize users' interaction with architecture (Deniz Kiraz & Kocaturk, 2019). In a 2012 study by Gabriel Wurzer, ABM was used in the early stage of planning complex buildings to create a complex layout in a spatial context (Wurzer, 2012). However, in this study, we aim to utilize ABM and ABMS In a design mechanism that integrates this tool. We aimed to create an architectural CAD-based tool that autonomously designs a responsive shade with ABMS embodied in it to dictate human behavior. This new approach is the methodological framework of using ABM and generative algorithms in computer-aided design. Such practice is novel since the previous researches used ABM limited in the early stages of planning.

2. Integrating ABM behavioral studies in design

By default, various mediums have been set in the design process to help the architect meet the physical goals set to accommodate human needs. These mediums have been practiced in limited steps of designing stages such as: mapping the space program in a static conventional method vis-à-vis, the

later computational algorithmic process, in which the design workflow is dynamic, and modifications can occur by need; therefore, the capability of these behavioral analyses is limited; while the latter has the potential to modify the design by every change, resulted from the simulation of human behavior; and a different answer can be achieved.

In this paper, our interest is to apply the user's behaviors informing the design parameters. Adopting an integrated process composed of performative and behavioral analysis systems, parametric form solutions, and computational design methods will result in a generative design profile that can be pushed to accommodate various criteria such as performance, user interactions, and a dynamic design system.

The approach needed to form this design methodology incorporates agent-based modeling embodied in a parametric algorithm to cohere behavioral attributes to digital agents in a digital environment, which serve to simulate the real word human-human and design-human interactions. Simultaneously, other design process elements are shaping in a parallel system and based on this factor. The purpose of the generated process in this research is to: Firstly, exploit emerging opportunities in forming a performative and responsive shade, echoing the user's needs, and secondly, resolve the insufficiencies in the status quo. For this matter, this research has taken advantage of newly formed behavioral and crowd analyzing methods, enabling us to examine experienced elements in existing space such as density, time-cost, and agents' path in various configurations. Then data collected will be integrated with custom-made algorithms to generate form and explore a combination of possibilities. Via this method, it is possible to study several scenarios to fuse expanding plans to existing architectural boundaries while refining performance and user experience.

2.1. AGENT-BASED MODELING

ABM systems consist of an environment in which autonomous entities able to make decisions based on a set of rules called agents. At the most superficial level, an agent-based model consists of a system of agents and their relations. Even a simple agent-based model can express intricate behavior patterns and render valuable data regarding the dynamics of the real-world system it imitates. (Bonabeau, 2002). In various recent research applications, ABM demonstrated simulations and optimized complicated problem-solving contained interacting elements (Schwinn et al., 2014).

In traditional modeling, a linear behavior is assumed for individuals, while ABM provides a natural description of a system in which researchers can study aggregated properties of the simulation. ABM is also flexible, which means the user can add or subtract agents or sub-groups, fine-tune complexities of the agent behaviors and environment (Bonabeau, 2002).

UTILIZING BEHAVIORAL AGENT-BASED MODELING IN AN AUTOMATED INTEGRATIVE DESIGN PROCESS

These ABM simulations can be characterized as complex and adaptive in some ways since it consists of a network of interacting agents. It portrays a non-linear aggregated behavior that develops from individual activities of agents. Also, we can describe its collective result without studying the activities of any particular agent (Holland & Miller, 1991).

In the past few years, ABM has been used by many researchers to evaluate their design in a social-related manner to satisfy the user's needs and to improve the architecture's performative ability. In L. Kiraz's practice in 2019, a methodology was developed to evaluate different attraction points' engaging performance based on human behavior (Deniz Kiraz & Kocaturk, 2019).

2.2. APPLYING REAL-WORLD ATTRIBUTES TO ABM SIMULATION

As told before, Agent-based systems consist of an environment and the agent (s) that interact in this virtual domain regarding a set of rules. To evaluate our design performance throughout the process, ABM was employed as a tool in which social traits were added to agents, as a set of commands. The designed entities translated into the simulation's environment. Agents will interact with each other, and the geometry of their surroundings and will make decisions. Agents are placed in a virtual environment, which is a digital representation of existing real-world geometry. They are assigned goals which agents will follow by executing actions based on rules of engagement. The surroundings are made of boundaries, surfaces, stairs, and Entry/exit points. Agents generate from a specified entry and choose the fastest route to the destination dedicated. Each unit can modify the chosen route and alter it with consideration to its present situation. Data resulted from these experiments will be fed to the parametric design algorithm written to create an architectural form.

For ABM simulation, powerful software such as "Massmotion" can be utilized as it has been used for this exercise. In Massmotion, Agents move through the physical environment, and a social Forces algorithm based on Fruin's algorithm calibrates these units' movement. It is to be noted that this commercial software was validated in August 2015 in accordance with the International Maritime Organisation (IMO) and the National Institute of Standards (NIST). The speed that an agent is moving at results from their physical surroundings, individual attributes (such as gender and age), and their interaction with each other (Kinsey, 2015). Agents will emerge from the specified origin, continuously assess the immediate condition, and decide how to proceed in the environment until it reaches the goal destination. Using this framework for our ABMS, we can ensure that our design evaluations contain human behavior criteria in mind.

In this study, the ABM method is employed in forming a responsive and performative shade as an additive structure to existing buildings. As one of the main performances of a shaded pathway is to minimize the travel time cost, the main focus of this simulation is to explore the possible pedestrian path in which the designed shade and possible future projects in the site does not reduce the overall performance of adjacent services

3. Exercise Workflow

The design goal was to create a workflow that assesses an environment and autonomously creates a responsive shade with maximum efficiency of pathways, resulting in a space that answers to required factors of users, all with human behaviors at the core of the mechanism.

This workflow contains three essential parts: First, translating the existing architecture to a digital environment and mapping out the most performative and responsive spaces for pedestrians using ABM simulations. The next stage is creating a parametric algorithm to devise the space itself. Lastly, a modular expansion lets us exercise additional options that could be required later, such as thermal and structural analyses, adding new elements, or even mechanical actuators to create kinetic responses to users or surrounding changes.

The first step is the ABM simulation. For this matter, we utilized a commercial program that enabled us to run this task, knowing the result is verified and saving time to recreate a solution that already exists. In this step, the site's existing architecture (including floors, barriers, and entries) translates into a digital environment. The anticipated users and their digital parameters (age, individual tasks, and their total, resulting from studying the site data) are also translated into digital agents. With the simulation's start, the agents introduced will perform their tasks while interacting with each other in the digital world, representing the statuesque. The parameter needed for the created algorithm to render the shades with stated goals in mind is the agent-count map, various agent-density map, agent-experienced density maps. All of which can then easily be extracted from the raw data of the sim.

The second phase of this workflow is introducing sim results to the algorithm to create the shaded path. This path enables future users to proceed to their desired destinations while experiencing acceptable social distancing with other users, choosing the shortest distance to their chosen destination while reducing the time cost. Other than goals achieved using ABM, other secondary goals, thermal and visual comfort, are achievable by design decisions implemented in the algorithm. The resulting space can be introduced to ABM simulation for further review to ensure that the design's human and performative aspects remain unscathed by the algorithm.

UTILIZING BEHAVIORAL AGENT-BASED MODELING IN AN AUTOMATED INTEGRATIVE DESIGN PROCESS

However, if an additional increase in density value takes place resulted map will enhance the space attributes in an algorithm loop.

Finally, this method allows us to integrate the various design aspects and encompass more design criteria in an integrated design workflow. The created algorithm in this study only explores form and evaluation factors of designing. Never the less, it is possible to add computation structure analysis or introduce kinetic elements to architecture without sacrificing the integrity of design workflow. The Design Methodology is presented in figure 1:

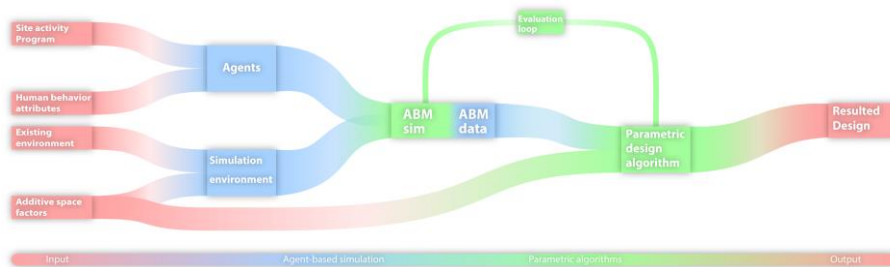

Figure 1. Design framework.

4. Project Design

4.1. IDENTIFYING DESIGN STEPS

Steps needed for this exercise are: Identifying the area of the environment, determining the agent's objectives, Running the simulation to gather necessary data, and creating the algorithm generating form.

To implement this strategy, we need to study the area that can affect the site activity, which here this activity focuses solely on a pedestrian perspective. The area required to run the simulation exceeds the site boundaries, which was the first challenge. The environment's boundary is set at the threshold where the user's entry and exit portals can be defined.

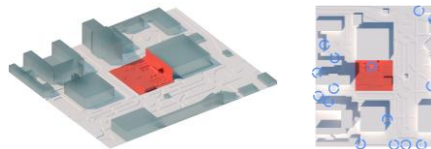

Figure 2. Simulation environment in red and portals emphasized in blue.

In the figures above, the project's site is highlighted in red. However, the environment needed for the simulation to render actionable results notably exceeded the project site, to the point that identifiable portals can represent

the entry and exit point of users without undermining the form of the path traveled by users.

For this study, the goal was to reduce time and travel costs and reduce experienced density for each user (more distance between people). People were distributed according to the total users of each activity on site. Goals are results of human behavior standards and, if achieved, would reduce the number of people present in public in a given time. Agents used in ABS are Autonomous and can interact with each other and the environment. They are task-directed and able to calculate new strategy if the current action fails. This ability makes the sim more adaptable and more elastic. Unlike the agents, the environment is static and unable to respond to the user's needs, but changes will be carried out via algorithms. Data gained from ABMS would be translated to parameters understandable by the algorithm. Furthermore, the form will be resulted based on these data.

4.2. ABM SIMULATION

This step is necessary if we are aiming to design with human behavior embedded in the design process. Using ABM, we can gather an understanding of how people act on the site, what path they choose, how much it will take for each user to complete their task, or even how much distance they can create between each other. An analytic simulation was done to understand how people behave in an existing condition to study the result of two design methods in comparison. After the simulation was done, data recorded by ABM presented how many agents were in the sim at any given time and their location. Using this, we can extract maps of agent count in the site and their experienced density presented below:

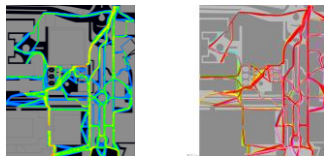

Figure 3. Sim 1: Agent max density (Right), agent's path (Left), existing environment.

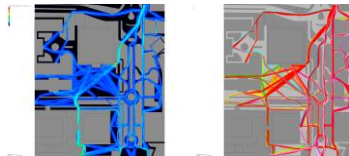

Figure 4. Sim 2: Agent max density (Right), agent's path (Left), In new environment.

A second sim was performed (barriers removed) to examine how different agents could do performance wise, having the behavioral attributes

UTILIZING BEHAVIORAL AGENT-BASED MODELING IN AN AUTOMATED INTEGRATIVE DESIGN PROCESS

in mind. The first evident change visible in the second simulation is the density reduced by letting the agents create their path by removing the existing landscape barriers, which allow users to define the architecture's spatial layout based on human behavior. Reduced travel time and distance costs mean users entered the site will complete their tasks faster than before, with fewer users utilizing the paths and experiencing less density.

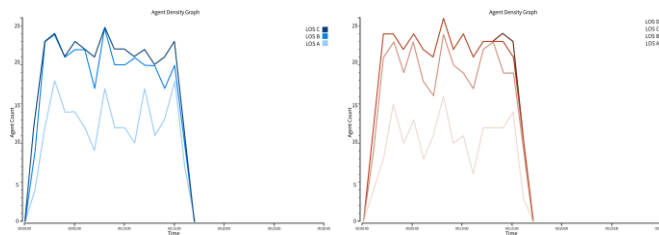

Figure 5. Agent density graph, existing site right, new workflow Left

We can compare how these two scenarios answer users' needs concerning performance and density in the figures presented above. In the first simulation (right), maximum average density exceeded the level of service (LOS) D, which means the minimum space is available for a given user is between 1.39 to 0.93 sq meters but, in the second simulation, the minimum space recorded per user is between 2.32 to 1.39 sq meters. Also, the area of LOS A (meaning each user has more than 3.24 sq meters) graph in the second sim is more than the first sim that means if we implement this workflow, we can create a space in which users can experience working with much more distance with each other and travel with ease. The designer can dictate to the algorithm which standard to be used for the project. For example, if we are about to save cost and material, we can allocate less space to the project until it reaches maximum acceptable LOS density. In contrast, in situations that we need people to get distanced from each other, the designer can change the PA (parametric algorithm) parameters so more space could be allocated to design; therefore, users can experience less density.

4.3. THE PARAMETRIC ALGORITHM

In the second stage of the workflow, an algorithm will generate the form based on the maps generated by ABMS and the designer's parameters. The algorithm itself consisted of four steps: data input, Dimension input, Surface generator, and sub-surface distributor.

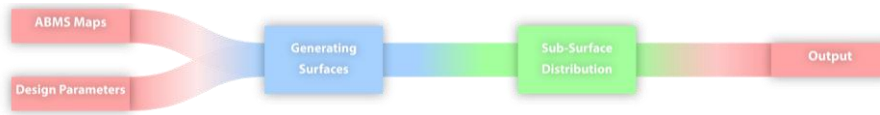

Figure 6. Algorithm structure

The input needed for PA consists of: maps generated by sim, which are translated for the algorithm to work with, the parameters related to physical attributes of the shade itself, and the elements (sub-surfaces) creating it. Maps obtained from the sim should be adjusted to the level of service needed. The density LOS considered for this project is 2.7 sq meters per user, so the minimum distance experienced is about 2 meters for any user. To achieve this standard average of the max density, define the space layout. To calculate the space, we start by calculating the maximum density of LOS's area to LOS A, and by adding the area of LOS A, the density drops. Since the area marked as LOS A in generated maps can be massive and less usable, we can reduce this space until the experienced density stands in an acceptable range.

$$LOS A = \frac{\sum_i (LOS_i * Area_i) - x (\sum_i Area_i)}{(x - LOS_a)}, i = b, c, \dots f \quad x = \frac{\pi * d^2}{4}$$

X= maximum area needed per person
 d= Average distance considered between users.

Figure 7. Formula to calculate the area of LOS A

We can calculate the LOS A area needed to keep max experienced density in the considered range with the math equation presented. In this exercise, the average distance between people "d" is considered to be 2 meters. "X" is the maximum area needed per person, which in this exercise is considered to be four sq meters since the unusual Circumstances of covid-19 dictates social distancing. It is to be noted that designers can change and adjust parameters to meet their requirements.

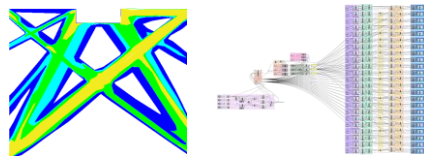

Figure 8. Max Density map configured for the parametric algorithm (Left), PA (Right)

The algorithm created for this step will create a virtual surface and a pathway beneath it. ABM simulation analyzes the newly created space to ensure that the PA output's performance and humane aspects are in an acceptable range defined by the project's needs.

UTILIZING BEHAVIORAL AGENT-BASED MODELING IN AN AUTOMATED INTEGRATIVE DESIGN PROCESS

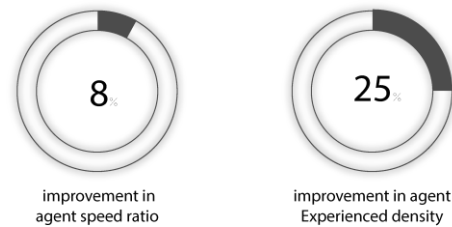

Figure 9. Improvement of the area under LOS A in agent's speed ratio and agent's Experienced density charts compared shows 8% and 25% improvement in performance.

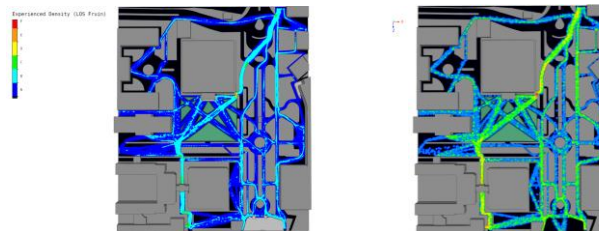

Figure 10. Average (Left) and maximum density (right) maps from PA's output evaluations.



Figure 11. Sub-surface's positioning (Left), Final outcome (middle), Surface section (Right)

Sub-surfaces and structural mesh will be distributed on the surface, designed to interact with changes in the environment to create shading in a kinetic manner while maximizing the user's visual and thermal comfort.

5. Conclusion

This practice aimed to study an integrated workflow in which ABM simulations were used to model and predict user behavior with a generative parametric design method. We briefly studied the use of ABMS in the architectural design process. Furthermore, an integrated methodological framework was created that combined a parametric design structure that inherited user satisfaction based on ABMS. The deployed method resulted in a performative and responsive structure additive to existing architecture without sacrificing performance. It is to be noted that this exercise was carried out in a limited format only to present the possibility of this

automated design workflow. Designers can generate their required algorithms and simulations and set the parameters based on each design's needed objectives. Nevertheless, utilizing this framework allows designers to start an automated and integrated design process with their goals ensured. One of the prime benefits of this design structure is the modularity and flexibility of the workflow itself. Objectives and design goals can be added or subtracted from the mechanism without resetting the design timeline. Using this method in an actual design case study demonstrates the effectiveness of the integrated design process in theory and practice. It is hoped that the practice presented could help researchers and architects to use the opportunity in this imminent shift and center the attention on human-based criteria while following the physical aspects in a parallel and integrated manner.

References

- Bonabeau, E. (2002). Agent-based modeling: Methods and techniques for simulating human systems. *Proceedings of the National Academy of Sciences*, 99(suppl 3), 7280–7287. <https://doi.org/10.1073/pnas.082080899>
- Deniz Kiraz, L., & Kocaturk, T. (2019). Integrating user-behaviour as performance criteria in conceptual parametric design. *CAADRIA 2019: Intelligent and Informed: Proceedings of the 24th Annual Conference of the Association for Computer-Aided Architectural Design Research in Asia*, 1–10.
- Holland, J. H., & Miller, J. H. (1991). Artificial Adaptive Agents in Economic Theory. *The American Economic Review*, 81(2), 365–370. JSTOR.
- Kinsey, M. (2015). The verification and validation of MassMotion for evacuation modelling. *ARUP, London, UK*.
- Schwinn, T., Krieg, O. D., & Menges, A. (2014). *Behavioral strategies: Synthesizing design computation and robotic fabrication of lightweight timber plate structures*.
- Wurzer, G. (2012). In-Process Agent Simulation for Early Stages of Hospital Planning. *IFAC Proceedings Volumes*, 45(2), 358–363.

CONDITIONS OF TACIT KNOWLEDGE TRANSFER IN ARCHITECTURAL COMPUTATIONAL DESIGN

An Analytical Review

HALA HOSSAM ELDIN, RAMY BAKIR

Arab Academy for Science, Technology and Maritime Transport

Email address: hossameldin.hala@gmail.com

Email address: r.bakir@aast.edu

AND

SHERIF ELFIKI

Email address: s.elfiki@aast.edu

Abstract. This paper investigates the transfer of tacit knowledge between designers and the computer in architectural design. Most research efforts in computational architectural design recently focus on the tangible and technical domains of the design process. This resulted in a lack of understanding of the role of other qualitative intangible domains, such as tacit design knowledge, in the computational design process. Despite the attempts of a few recent studies to tackle some tacit aspects within design computing, little research extended further to study how tacit knowledge can be transferred between different entities of the computational design process and how it can be represented. Through an analytical review, the paper will first discuss the notions of tacit knowledge in different disciplines, with particular emphases on architecture. Second, the study reviews the conditions and factors that influence the transfer of tacit knowledge between humans, and accordingly between the human and the computer, as addressed by different architects and authors. The study particularly emphasizes the significance of a human-computer symbiotic relationship for the process of tacit knowledge transfer to take place. In conclusion, this paper presents a theoretical basis for understanding and facilitating the transfer and representation of tacit knowledge in a computational design environment.

Keywords: *tacit knowledge transfer, computational design, designer-computer interaction*

ملخص. تبحث هذه الورقة عملية نقل المعرفة الضمنية (Tacit Knowledge) بين المصممين والحاسب الآلي في عملية التصميم المعماري. تركز معظم جهود البحث في التصميم المعماري الحسابي مؤخرًا على المجالات الملموسة والتقنية لعملية التصميم، مما أدى إلى عدم الوضوح في فهم دور المجالات النوعية و الغير الملموسة الأخرى و منها المعرفة الضمنية محط إهتمام هذا البحث. على الرغم من محاولات بعض الدراسات الحديثة لمعالجة بعض الجوانب الضمنية في حوسبة التصميم، إلا أن القليل من البحث امتد لدراسة كيفية نقل المعرفة الضمنية بين الكيانات المختلفة المشاركة في عملية التصميم الحسابي وكيف يمكن تمثيلها. من خلال مراجعة تحليلية، سنتناقش هذه الورقة أولاً مفاهيم المعرفة الضمنية في مختلف التخصصات، مع التركيز بشكل خاص على الهندسة المعمارية. ثانيًا، تستعرض الدراسة الظروف والعوامل التي تؤثر على نقل المعرفة الضمنية بين البشر، وبالتالي بين الإنسان و الحاسب الآلي، كما تناولها العديد من المعماريين والمؤلفين. تؤكد الدراسة بشكل خاص على أهمية العلاقة التكافلية بين الإنسان و الحاسب الآلي و ذلك في إطار عملية نقل المعرفة الضمنية. في الختام ، تقدم هذه الورقة أساسًا نظريًا لفهم وتسهيل نقل وتمثيل المعرفة الضمنية في بيئة تصميم حسابية.

الكلمات المفتاحية: نقل المعرفة الضمنية ، التصميم الحسابي ، التفاعل بين المصمم والكومبيوتر.

1. Introduction

Recent research efforts investigating design knowledge domains are primarily focused on the tangible and technical aspects of the design process such as structure, heating, ventilating and air-conditioning (Al-Jokhadar and Jabi, 2016; Bernal, 2016; Coyne, 2014; Rybczynski, 2013). Hence these domains are the ones widely embedded in the computational design process, turning its focus to problem solving rather than problem setting. This resulted in a lack of identification of the qualitative and more intangible human-centered domains of the design process, such as tacit design knowledge. Furthermore, the ambiguous nature of tacit knowledge poses a challenge to investigate its transfer and representation in computational environments among design entities, particularly between the designer and the computer (Gourlay 2002; Bernal, 2016).

Many architects expressed similar concerns about the use of computation in design. From Alexander (1964) who criticized those thoughtlessly absorbed with the application of the tool as an end in its own right, and argued that it will allow the designer to consider only those tangible aspects of the problem which can be encoded. To Rittel (1972), who argued that the wicked problems of innovative design, that depend on the deliberation of different perspectives and judgements of different design entities cannot be implemented in an automated system that depends on specific design measures. Negroponte (1970), though known for his contributions to design computing, argued that the handling of qualitative information is presumed hopeless for the constitution of 'machines' at the time, and is granted feasibility only through the abortive techniques of quantification. While

CONDITIONS OF TACIT KNOWLEDGE TRANSFER IN ARCHITECTURAL COMPUTATIONAL DESIGN: AN ANALYTICAL REVIEW

Schön (1992) believed that computers are incapable of establishing the reflective conversation the designer needs to have with the design situation.

More recently, the American Institute of Architects California Council (AIACC) (2012) acknowledged the pervasiveness of the parametric design era, and expressed that mathematical and algorithmic procedures proved to be far too rigid to productively engage the complex cultural, societal, economic, and political projects facing architects today. Rybczynski (2013) criticized computational parametric design, arguing that designers utilize computational tools either to create complex building forms that disregard other contextual parameters, or for mere technical ends such as simulations of energy efficiency, lighting and ventilating. While Coyne (2014) stated that there are parametric definitions of crowds, swarms and mobs, but yet there is nothing that models human sociability and responses to environments in total.

However, though acknowledging the previous critiques about design computation, few recent studies attempted to focus on tacit features of the computational design process. Those features were referred to in different terms such as *design interpretation* (Stahl, 1993), *strategic knowledge* (Kvan and Candy, 2000), *design intent* (Abdelmohsen, 2012; Sanguinetti and Kraus, 2011), *design experience* (Bernal, 2016), or *social and environmental design patterns* (Al-Jokhadar and Jabi, 2016).

Mostly, those studies are concerned with how to highlight such knowledge to be able to re-use it in different phases of the design process, creating methods for its computational support.

Yet the research in this area still lacks the thorough investigation of the nature and meaning of tacit knowledge domains, and how they are transferred and represented between different design entities prior to implementing them in the computational design process.

2. Method

This paper conducts a literature review that adopts a sequential strategy (Tobon et al., 2019) which is comprised of three main research goals building conceptually upon each other. The first goal identifies studies that investigated the definitions and meanings associated with tacit knowledge in different disciplines. The second goal is to identify studies that related tacit knowledge to the architectural discipline. The third is to identify theories and literature that address human-human tacit knowledge transfer and representation, and its relation with literature addressing approaches of human-computer knowledge transfer.

For each research goal, three phases were applied; an initial research phase where we identified keywords associated with the goal addressed and used them to formulate a search statement based on the objective of this review; a sampling and selection of literature phase where research filters were applied that correspond to the aim of the research goal; and an analysis of literature phase where a process of characterizing and comparing the selected studies and the interventions between them is conducted.

3. The Notions of Tacit Knowledge

The term Tacit Knowledge (TK) is deeply studied in a broad range of disciplines. The purpose of this review is to first; understand the meanings associated with the term, and second; to highlight its importance and applications in the field of architecture

3.1. TACIT KNOWLEDGE IN DIFFERENT DISCIPLINES

Polanyi (1966) coined the term *Tacit Knowing* and argued that "*we can know more than we can tell*". He described TK as knowledge that cannot be articulated or spoken, but rather demonstrated and imitated, and is acquired through learning and practice.

One of the disciplines that exhausted the study of TK is Knowledge Management especially Organizational Studies. Nonaka and his colleagues (1995; 1996) introduced the concept of TK into knowledge management and defined it as a non-linguistic non-numerical form of knowledge that is highly personal, context-specific and deeply rooted in individual experiences, ideas, values and emotions. Nonaka distinguished between *technical TK*; meaning skills or concrete know-how, and *cognitive TK*; which refers to ingrained schema, beliefs and mental models that are taken for granted. According to Scharmer (2000), TK described by Polanyi and Nonaka denotes two types of knowledge as well, *embodied TK*; which is knowledge that is embedded in everyday practices and based on action, and *self-transcending knowledge*; which is based on imagination and aesthetic experience. Baumard's work (1999) differentiated between *implicit knowledge*; something we might know but do not wish to express and *TK*; which is something that we know but cannot express. He pointed out the importance of TK because *expertise* rests on it, however, unlike Nonaka he believed TK can be a property of not only individuals, but of groups of people as well.

In a slightly different sense, Hutchins (1995), Krogh and Roos (1995), Choo (1998) see that TK resides in *relationships*. They distinguish between an individual type of TK and a social type implying a collective aspect or dimension of TK. They explain this collective phenomenon exists among

CONDITIONS OF TACIT KNOWLEDGE TRANSFER IN ARCHITECTURAL COMPUTATIONAL DESIGN: AN ANALYTICAL REVIEW

members of groups that relate to working together, and resides in their information flows, decisions and shared practices.

Switching to other disciplines, Collins (2001) defines TK in the scientific field as knowledge or abilities that can be passed between scientists by *personal contact* but cannot be passed on in formulae, diagrams, or verbal descriptions. For Wagner and Sternberg (1985) in the field of Practical Intelligence, TK corresponds to *practical know-how* or *procedural knowledge*, that can be acquired only *through experience* as it is not usually taught. While in Artificial Intelligence, Janik (1988) argued that the term TK is used in two senses, first; to refer to knowledge that could be made explicit, but which has not yet been so rendered. Second, to those aspects of human experience which are wholly knowable self-reflectively, but are incapable of precise articulation.

Table (1) presents a summary of the aforementioned review, synthesizing the different notions of TK in different disciplines, the views about its transferability between people, and its types. It is worth noticing first; the similarity in the types of tacit knowledge mentioned by some authors, be it *individual or social*, or whether it is denoting personal *skill and intuition*, or social *everyday reflections*. Second and more importantly; are the situations and conditions that almost all authors agree upon, where TK is constructed or communicated. This specific column includes some personal conditions such as *practice, individual experience, and expertise*, and other social conditions related to *interactions and relationships* with other people.

TABLE 1. A summary for the different notions of tacit knowledge in different disciplines, their views about its transfer and its types. Source: authors.

Field of Study	Author	TK Definition	TK Transfer	TK Types
Philosophy	Polanyi, 1966	knowledge that cannot be articulated, rather demonstrated	Learning, practice	personal knowledge
Knowledge Management	Nonaka, 1995, 1996	non-linguistic non-numerical form of knowledge that is highly personal and context specific	individual experiences	1. technical TK 2. cognitive TK
	Scharmer, 2000			1. embodied TK 2. self-transcending
	Baumard, 1999	something that we know but cannot express that is personal	expertise, daily activities	1. implicit knowledge 2. tacit knowledge
	Hutchins, 1995		Social workforce	1. individual TK 2. group TK
	Von Krogh, and Roos, 1995		attitudes, information flows, decisions	1. individual TK 2. group TK
	Choo, 1998		shared practices, working together	1. individual TK 2. group TK
Science Sociology	Collins, 2001	knowledge that cannot be passed on in formula or diagrams	personal contact	
Practical Intelligence	Wagner and Sternberg, 1985	an attribute of individuals that is practical rather than academic and informal rather than formal	experience	practical know-how, procedural knowledge
Artificial Intelligence	Janik, 1988	aspects of human experience which are knowable self-reflectively but are incapable of articulation		

3.2. TACIT KNOWLEDGE IN ARCHITECTURE

Although the notion of TK is thoroughly discussed in different disciplines, it is not discussed as such in the field of architectural design. This section highlights what was mentioned in the few studies investigating TK in the architectural practice, with a special focus on architectural computation.

Schön (1983) was first to explicitly acknowledge the concept of TK in architectural practice. In ‘The Reflective Practitioner’, he distinguished between two notions of TK in practice; *knowing-in-action*, meaning intuitive judgment and skill, and *reflection-in-action*, which is the practitioners’ reflection in a context of action where they construct on phenomena they perceive as incongruent with their intuitive understandings.

However, in his trials for computing Schön (1992) argued that a computer program cannot on its own construct a design situation the way an architect does, and finds computers unable to reach the level of reflective conversation that requires different human intuitive, perceptual and linguistic skills.

Stahl (1993) studied in his dissertation how to computationally support *interpretation* in design, that he defines as “*The process by which designers transform their tacit preunderstanding into explicit knowledge*”. Taking after Schön’s TK types, he argues there are two aspects for interpretation; first the *tacit preunderstanding* based on previous background knowledge, where items from this preunderstanding can be articulated explicitly. Second, the possibility of revising that preunderstanding based on *discoveries* that are opened up by it.

In more recent studies, Kvan and Candy (2000) investigated how to create a design collaborative environment that can computationally support the communication of designers’ *strategic knowledge*. Abdelmohsen (2012) explored how *design intent* is communicated among Architecture, Engineering and Construction design teams within the context of BIM-enabled practice. Sanguinetti and Kraus (2011) focused on the use of parametric modeling to capture *design intent* and to support the representation of experiential parameters. In a similar vein, Al-Jokhadar and Jabi (2016) attempted to integrate parametric models with qualitative dimensions that reflect the spatial, social, and environmental patterns. Bernal’s dissertation (2016) developed a framework for capturing and re-using the *TK that expert designers embed* in their patterns of organization of their designs by means of computational methods and techniques in a trial of augmenting the capability of designers to explore alternatives.

Regarding studies that directly addressed TK in architectural computation, Woo (2005) investigated the impact of *tacit design knowledge* on design performance in a distributed design environment supported by Computer-Mediated Communication software.

CONDITIONS OF TACIT KNOWLEDGE TRANSFER IN ARCHITECTURAL COMPUTATIONAL DESIGN: AN ANALYTICAL REVIEW

Almost all the reviewed studies that discussed computational support of TK, presented in Table (2), were concerned with capturing it and supporting it with a convenient software to enhance its communication in computational design fields. None of them though, was concerned with studying the basic conditions and circumstances that have to be provided in the work environment for TK to easily flow between design entities.

TABLE 2. A summary for the different notions of tacit knowledge in architecture, and what different architects proposed for its computational support. Source: authors.

Authors and Date	TK Notion	TK Computational Support
Schön, 1983	knowing-in-action, reflection-in-action	—————
Stahl, 1993	design interpretation	HERMES, a substrate for building design environments
Kvan and Candy 2000	strategic knowledge	computer system that supports textual communication
Woo, 2005	tacit knowledge	Computer-Mediated Communication (CMC) software
Abdelmohsen, 2011	design intent	Building Information Modelling (BIM)
Sanguinetti and Kraus, 2011	design intent	parametric modelling
Al-Jokhadar and Jabi, 2016	social, and environmental patterns	syntactic-discursive model
Bernal, 2016	design expertise	meta-modeling process based on Model-Based Systems Engineering (MBSE)

4. Tacit Knowledge Transfer Between Humans

Understanding what TK entails in different disciplines and in architecture so far, raises the question about its communication. This section investigates the different modes of TK transfer between human beings from different points of view. Followed by a discussion of the main conditions required for TK transfer between humans. This review provides the basis for formulating the conditions for TK transfer between the designer and the computer.

4.1. MODES OF TRANSFER

From a philosophical point of view, Gourlay (2002) presented an interesting discussion in his piece ‘Tacit Knowledge, Tacit Knowing or Behaving’ about how tacit knowledge is represented between humans, where he related tacit knowledge/knowing to verbal and non-verbal signing. He based his discussion on the writings of Dewey and Bentley (1949) who were interested in studying the *Knowing* process. Dewey and Bentley argued that *Knowings are Behaviors*, and that behavior can best be studied in terms of *organism-environment transactions*. Furthermore, they argued that behavior is necessarily entailing signing or sign process, and since they have established

that behavior is knowing, hence their conclusion that sign process held knowledge. On this basis, Gourlay argued that *TK corresponds to signaling*, and explicit knowledge to designation/ name or symbol.

Bruner (1966) proposed that human beings translate their experience of the world into a model or some kind of representation in three ways: *Enactive*; meaning learning through action, such as being involved in teaching someone to ride a bicycle, *Iconic* representation; that depends on visual or other sense organs and upon summarizing images by means of which we are able to detect patterns, and *Symbolic* representation; referred to words or language.

Gourlay mentioned Bruner in his discussion. He further argued that Polanyi himself also provided evidence that tacit knowing can usefully be viewed as a *non-verbal semiotic process*, and even occasionally discussed it in sign-process terms. In conclusion, Gourlay argued that human knowledge and the representation of that knowledge involves a whole range of forms of sign process, and that TK in particular resides in *the non-linguistic/nonverbal/signal like* modes of human representations.

From a more practical point of view, Schön (1983) discussed the practitioners' TK, *Reflection-in-action*, in different professional contexts illustrating how TK flows in each between parties of the professional situation. He discussed one-to-one situations as in an architectural design studio between instructor and student, where TK flows through the *reflective one-to-one conversation*. While in situations where more than two individuals are involved, as in a scientific investigation, scientists reflect by *seeing as*, meaning by the perception of similarity between a certain situation and another that was seen before. Schön further explains through an experiment of a systems engineer how TK is transferred in social experiments through *social intervention* and the integration with the surrounding context. He also argued that in a planning or a management profession, TK flows mainly through *reflecting on other professional's behaviors*.

In his discussion about interpretation in design Stahl (1993) explains that people understand things because they are *actively involved* with them in the world. He argues that the significance of artifacts for a person is determined by the artifacts' *relationships to other artifacts, activities, and people* whose significance are already understood as part of the *person's situation*. He emphasizes that the act of understanding combines personal and socially shared perspectives on the world, and that all of this takes place primarily in tacit un verbalized ways.

CONDITIONS OF TACIT KNOWLEDGE TRANSFER IN ARCHITECTURAL COMPUTATIONAL DESIGN: AN ANALYTICAL REVIEW

4.2. CONDITIONS OF TRANSFER

Gourlay's discussion (2002) established that for TK to be transferred it is manifested in *non-verbal semiotic processes* between human beings. Digging more in semiotics, this indicates that for individuals to share their TK with others, they have to share the same *medium, language, culture and background* to understand the designation of those non-verbal signs and the method of communicating them (Chandler,2001).

Schön's discussion (1983) entailed some conditions for the process of reflection-in-action to happen that he refers to as the *Structure of reflection-in-action*. These conditions involved *evaluating experiments in problem setting* (reflective conversation within a design situation), *bringing past experience to bear on a unique situation* (designer's expertise), *rigor in on-the-spot experiment* (taking the decision to stop experimenting and/or reflecting when it makes no more sense), *virtual worlds* (creating a world that is constructed by the medium used, and is more limited than the real world), and *stance toward inquiry* (the designer imposing an order of his own framing the situation).

Furthermore, Schön mentioned some factors that vary from one practitioner to another, that are essential to the process of reflection-in-action and *TK transfer*. These factors include; *the media*, languages, and repertoires that practitioners use to describe reality and conduct experiments; *the appreciative systems* they bring to problem setting, to the evaluation of inquiry, and to reflective conversation; *the overarching theories* by which they make sense of phenomena; and *the role frames* within which they set their tasks and through which they bound their institutional settings (Schön, 1983).

On a similar track to Schön's, Stahl's analysis (1993) of interpretation in design, distinguished three characteristics for the process of interpretation. First; *being situated*; meaning that what is to be interpreted is tacitly understood by virtue of its associations within an open-ended network of related artifacts, people, human purposes, and other concerns. Second, *having a perspective*; where he argues that there has to be a focus on a certain aspect or that a specific approach is taken in interpreting something. Third, *using language*, a particular vocabulary should be available as part of a tradition that provides a conceptual framework for the interpretive task.

From the discussion of sections 3 and 4, a very important observation could be made. That is, none of the authors who discussed the transfer of TK between humans was concerned with the explicit representation of TK to be transferred, as much as they were concerned with the conditions (actions, tools, type of context or environment) that allows this transfer to take place.

Moreover, it is noticed that TK transfer between people entails first and foremost, *interaction*. The type of interaction that one can describe as reciprocal, two-way or mutual, described by the authors as *enactive, reflective or actively involved*. This reciprocal interaction is not confined to two people, rather it is a *reciprocal system* or network that can include two or more people, and as will be described later, people and surroundings.

There also appears to be a consensus among the authors about two types of conditions for TK transfer, illustrated in figure (1). The first type is concerned with personal aspects of the individual involved in the interaction process such as one's own *stance or perspective* towards a subject, the *expertise* that one recalls, and the *decisions* one makes. The second type of conditions are social, related to the mutual reciprocal process itself, and to all individuals participating in the interactive system together such as the presence of a *common language/sign process* that is understandable to all, a *familiar medium* and a *context of action*.

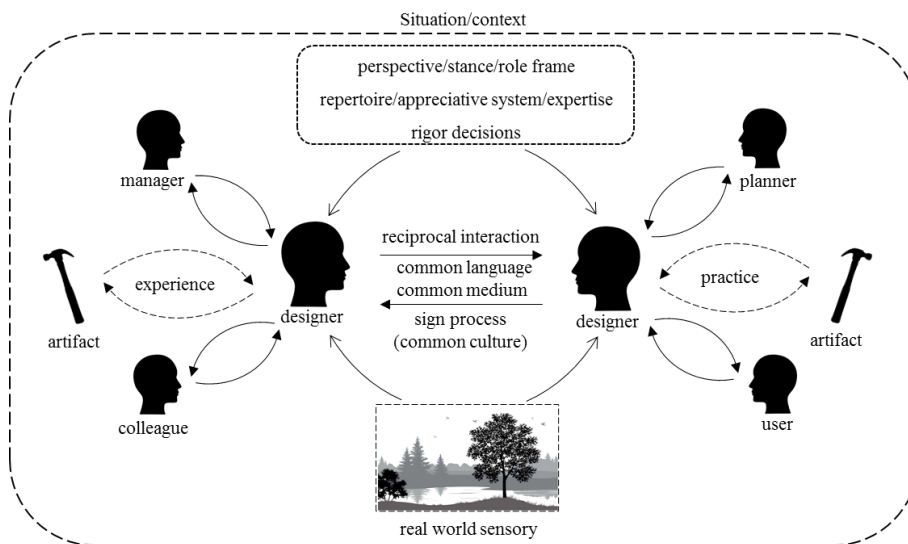

Figure 1. Illustrating the personal and social conditions of tacit knowledge transfer between human beings according to different disciplines. Source: authors.

5. Discussion: On Tacit Knowledge Transfer Between the Designer and the Computer

Building on the previous discussion of conditions associated with TK transfer between humans, one is compelled to ask; What happens if we replace one of the two designers in figure (1) with a computer?

In fact, the condition of *reciprocal interaction* between humans discussed in the previous section has been open to discussion before by architects and

CONDITIONS OF TACIT KNOWLEDGE TRANSFER IN ARCHITECTURAL COMPUTATIONAL DESIGN: AN ANALYTICAL REVIEW

theorists who believed in the computer as an inevitable and necessary aid to the designer in the design process (Negroponte, 1970, 1975; Cross 1974, 2001; Kalay et al., 1990). They argued that for the computer to perform successfully in a design task, especially problem-solving tasks, a *dialogue* should be established between the designer and the computer, and called for a *designer-computer symbiosis*. Furthermore, they argued that the computers must be able to access and use the knowledge of designers, and that the formulation and representation of design knowledge are among the most critical tasks facing the computation of design.

Studying the previous diagram more thoroughly, it shows that TK does not only flow between the two designers under the discussed conditions, but is also transferred between each designer and other secondary parties. Meaning, that beside the mutual tacit bond formed between any two (or more) design entities, each entity has its own individual TK and understandings that are build up due to its interactions with other people and surroundings. This indicates that for TK to flow between the designer and the computer, the computer must be able to gain its own TK from other people or surroundings as well to be able to *co-design* if one might say; and have its own stance and perspective towards design situations. Interestingly enough, this issue was raised by Negroponte (1970) arguing that for a vibrant un-interrupted stream of ideas to flow between the designer and the machine, the machine must be evolutionary and *adaptable*. It must receive *direct sensory information from the real world (sensory machine)*, and must be *capable of overiewing other designers works (parent machine)*.

Moreover, other conditions as establishing a *common language* and a *signing system* for TK transfer between the human and the computer were addressed by semiotics and HCI in addition to architecture. Andersen (1990) for instance developed a semiotic approach for HCI to design systems that successfully support tasks in work environments based on the transformations of the meanings of office work language into signs for the computer within an interface. Nake and Grabowski (2001) also promoted for a semiotic approach for HCI that suits the dichotomy between how humans and computers interpret signs (humans depending on knowledge and social codes, computers depending on signal processing of commands of a computer program). Negroponte (1970) on the other hand pointed out that one of the barriers of information flow between the designer and the computer is the absence of *common language*, meaning the designer should not have to be a computer specialist or in need of a software engineer to translate his knowledge to the computer.

Figure (2) presents an illustration of the conditions and factors required for TK transfer between the designer and the computer.

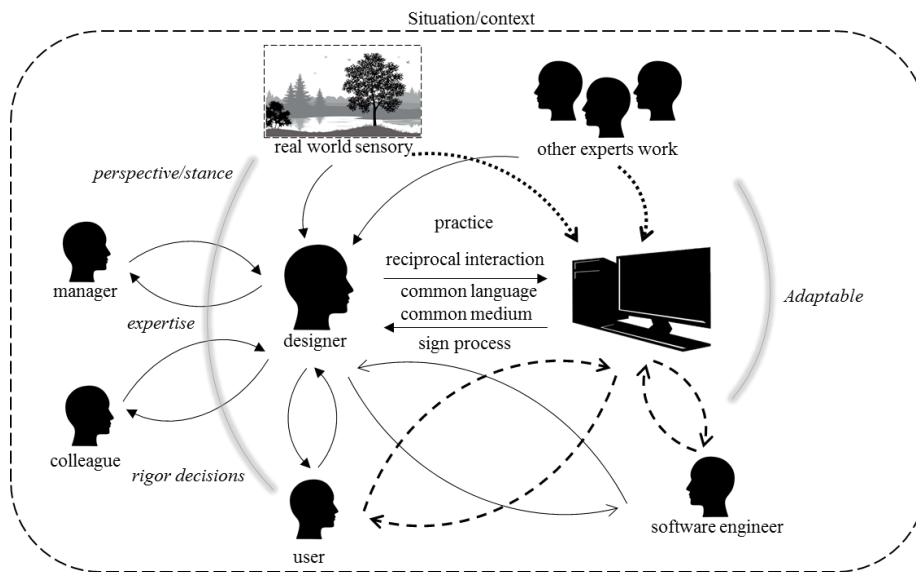

Figure 2. Illustrating the conditions, characteristics and relationships required for TK transfer between the designer and the computer. Source: authors.

6. Conclusion

This research investigated the meaning of Tacit Knowledge by reviewing the notions associated to it in architecture and in other different disciplines, and provided an understanding of the methods of its communication in the computational design process. TK is a type of knowledge that is generally overlooked especially in computational design fields. The issue of how it can be transferred and represented between humans, and more importantly between the designer and the computer is critical to be addressed in computational design. By means of a sequential research strategy that digs into three main research goals (discussed in sections 3 and 4), this research presents a theoretical basis for studying the conditions and factors associated with enhancing TK transfer in computational design environments.

The flow of TK is reciprocal in nature, and the study of TK shares that feature. This research argued that to study the transfer of TK in computational architecture, relying on the field of architecture only is not enough. Architecture therefore has to be in continuous reciprocal/interactive contact with other disciplines to develop more advanced frameworks for TK transfer, especially in the computational realm.

Another essential argument this research raises is that to study TK transfer between the designer and the computer, we have to first take a close look at TK flow between human beings. Most of the reviewed studies that

CONDITIONS OF TACIT KNOWLEDGE TRANSFER IN ARCHITECTURAL COMPUTATIONAL DESIGN: AN ANALYTICAL REVIEW

tackled TK in architecture focused on the computational point of view, where the ‘computer’ is involved. While in fact, learning from the human-human conditions proved to be a beneficial aid in understanding the human-computer conditions, especially when several connections were found between the literature discussing human-human TK transfer and the one discussing human-computer knowledge flows.

For future research, we intend to gain a more in-depth understanding of TK transfer between the human and the computer, through investigating TK in theories of phenomenology and technology embodiment, addressing the individual aspect of TK, and theories of cybernetics and distributed cognition, where the social notion of TK can be investigated. Furthermore, we intend to provide practical evidence for our theoretical framework, investigating the current state of TK within computational design practice, and the latest developments in man-machine systems.

7. References

- ABDELMOHSEN, S., 2012. *Communication of Design Intent in BIM-Enabled Architectural Practice: An Ethnographically Informed Analysis*. Lambert Academic Publishing (LAP) GmbH & Co. KG, Saarbrücken, Germany, ISBN: 978-3-8473-7859-4.
- AIA CALIFORNIA, 2012. Parametric design: a brief history, available at <https://aiacalifornia.org/parametric-design-a-brief-history/>, accessed 20 october 2020.
- AL-JOKHADAR, A., and JABI, W., 2016. Humanising the computational design process, *proceedings of ASCAAD 16*, London, UK.
- ALEXANDER, C., 1964. A much asked question about computers and design. *Proceedings of Architecture and the Computer*, Boston Architectural Center, Boston.
- ANDERSEN, P.B., 1990. *A theory of computer semiotics: semiotic approaches to construction and assessment of computer systems*. Cambridge: Cambridge University Press.
- BAUMARD, P., 1999. *Tacit knowledge in organizations*. London: Sage Publications.
- BERNAL, M., 2016. *Meta-modeling design expertise*. PhD, Georgia Institute of Technology, Georgia.
- BRUNER, J.S., 1966. *Toward a theory of instruction*. Cambridge, Massachusetts: Belknap Press.
- CHANDLER, D., 2001. *Semiotics: the basics*. London: Routledge.
- CHOO, C., 1998. *The knowing organization: how organizations use information to construct meaning, create knowledge, and make decisions*. New York: Oxford University Press.
- COLLINS, H.M., 2001. Tacit knowledge, trust and the Q of sapphire. *Social Studies of Science*, 31 (1): 71-85.
- COYNE, R., 2014. What’s wrong with parametricism. *Reflections on Technology, Media & Culture*, available at <https://richardcoyne.com/2014/01/18/whats-wrong-with-parametricism/>, accessed 25 october 2020.
- CROSS, N., 1974. *Human and machine roles in computer-aided design*. PhD, Victoria University.
- CROSS, N., 2001. Can a machine design?. *Design Issues*, 17 (4): 44-50.

- DEWEY, J., and BENTLEY, A.F., 1949. *Knowing and the known*. Boston: Beacon Press.
- GOURLAY, S., 2002. Tacit knowledge, tacit knowing or behaving ?. *Proceedings of OKLC 3*, Athens, Greece.
- HUTCHINS, E., 1995. *Cognition in the wild*. Bradford: MIT Press.
- JANIK, A., 1988. Tacit knowledge, working life and scientific method. Chapter 6 in GÖRANZON, B. and JOSEFSON, I., eds. *Knowledge, skill and artificial intelligence*. London & Berlin: Springer-Verlag, pp.53-63.
- KALAY, Y., SWERDLOFF, L., and MAJKOWSKI, B., 1990. Process and knowledge in design computation. *Journal of Architectural Education*, 43 (2): 47-53.
- KROGH, G., and ROOS, J., 1995. *Organizational epistemology*. London: Palgrave Macmillan.
- KVAN, T., and CANDY, L., 2000. Designing collaborative environments for strategic knowledge in design. *Knowledge-Based Systems*, 13 (6): 429-438.
- NAKE, F., and GRABOWSKI, S., 2001. Human-computer interaction views as pseudo-communication. *Knowledge-Based Systems*, 14 (8): 441-47.
- NEGROPONTE, N., 1970. *The architecture machine*. USA: MIT Press.
- NEGROPONTE, N., 1975. *Soft architecture machines*. Cambridge, Massachusetts: The MIT Press.
- NONAKA, I., and TAKEUCHI, H., 1995. *The knowledge-creating company: how japanese companies create the dynamics of innovation*. Oxford: Oxford University Press.
- NONAKA, I., TAKEUCHI, H., and UMEMOTO, K., 1996. A theory of organizational knowledge creation. *International Journal of Technology Management*, 11 (7-8): 833-845.
- POLANYI, M., 1966. *The tacit dimension*. Chicago and London: The University Of Chicago Press.
- RITTEL, H., 1972. Second-generation design methods. In CROSS, N., 1984, ed. *Developments in Design Methodology*, New York: Wiley, pp. 317-327.
- RYBCZYNSKI, W., 2013. Parametric design: what's gotten lost amid the algorithms. *Architect Magazine*, available at https://www.architectmagazine.com/Design/parametric-design-whats-gotten-lost-amid-the-algorithms_o, accessed 22 october 2020.
- SANGUINETTI, P., and KRAUS, C., 2011. Thinking in parametric phenomenology. *Proceedings of ACADIA Regional 11, Parametricism (SPC)*, Lincoln, Nebraska, USA.
- SCHARMER, C.O., 2000. Organizing around not-yet-embodied knowledge., in KROGH, G., NONAKA, I., and NISHIGUCHI, T., eds., *Knowledge Creation: A Source of Value*. London: Palgrave Macmillan UK, pp. 36–60.
- SCHÖN, D.A., 1983. *The reflective practitioner: how professionals think in action*. USA: Basic Books.
- SCHÖN, D.A., 1992. Designing as reflective conversation with the materials of a design situation. *Research in Engineering Design*, 5(3): 131-147.
- STAHL, G., 1993. Interpretation in design: the problem of tacit and understanding in computer support of cooperative design. PhD, University of Colorado, Boulder.
- TOBON, J.G., BOHORQUEZ, F., and ALZATE, O., 2019. Metacognition in the wild: metacognitive studies in design education, *Proceedings of 5th International Conference for Design Education Researchers DRS*, METU, Ankara, Turkey.
- WAGNER, R.K., and STERNBERG, R.J., 1985. Practical intelligence in real-world pursuits: the role of tacit knowledge. *Journal of Personality and Social Psychology*, 49 (2): 436-458.
- WOO, J., 2005. *Sharing tacit design knowledge in a distributed design environment*. PhD, Texas A&M University, Texas.

D1.P2.S1

ARCHITECTONIC LANGUAGES I

DESIGNING FACADES BASED ON DAYLIGHT PARAMETER

A Proposal for the Production of Complex Surface Panelization

GİZEM ÖZEROL, SEMRA ARSLAN SELÇUK

Gazi University, Department of Architecture, Ankara, Turkey

Email address: ozerol.gizem@gmail.com

Email address: semraarslanselcuk@gmail.com

Abstract. Nowadays, due to the increasing demand for sustainable design and energy efficient buildings, “performance” is becoming a key parameter behind design decisions. Traditional design methods may be insufficient in both evaluating the energy performance and producing optimized design alternatives, as well as in understanding the relationship between design variables and performance metrics. Recently, via parametric design tools and optimization algorithms, a wide range of design methods have been formed and various performance data have been measured and optimized. In this context, this study offers a design approach to integrate sustainability principles and physical environmental conditions into the design process as a quantifiable parameter used to improve building performance. Further, this study aims to design a facade and its modules based on environmental conditions in İstanbul, Turkey. The design process focuses on daylight radiation and the analysis of environmental data using a digital model. Rhino and Grasshopper software was used as the digital medium for design and Ladybug-Honeybee plugins were utilized in the analysis. Based on İstanbul’s weather data obtained from Ladybug, optimization of the model consisting of the first diagrams was achieved during the environmental analysis process. The model underwent the analysis process created for facade panelization and the panelization process was carried out according to daylight radiation. After the design process is completed, the model will be ready for production for the 3d printed model. As a result of the study, a discussion developed on how to integrate precast concrete panels into the design of complex geometrical surfaces using computational design techniques.

Keywords: *Daylight analysis, Ladybug-Honeybee analysis, Panelization, adaptive surfaces, complex surfaces.*

DESIGNING FACADES BASED ON DAYLIGHT PARAMETER: A PROPOSAL FOR THE PRODUCTION OF COMPLEX SURFACE PANELIZATION

ملخص. نظرًا للطلب المتزايد على التصميم المستدام والمباني الموفرة للطاقة في الوقت الحاضر أصبح "الأداء" معيارًا رئيسيًا عند اتخاذ القرارات التصميمية في المباني. وفي هذا الصدد قد تكون طرق التصميم التقليدية غير كافية لأجل تقييم أداء الطاقة أو إنتاج البدائل الأمثل للتصميم، أو في فهم العلاقة بين متغيرات التصميم ومقاييس الأداء. في الأونة الأخيرة ساهمت أدوات التصميم البارامترية وخوارزميات التحسين في تشكل نطاق واسع من مجالات التصميم وفي قياس بيانات الأداء المختلفة وتحسينها. وفي هذا السياق، تقدم هذه الدراسة منهجًا تصميميًا لدمج مبادئ الاستدامة والظروف البيئية في عملية التصميم كمعيار قابل للقياس الكمي مما سيحسن من أداء المبنى. يهدف البحث إلى تصميم واجهة ووحداتها الأساسية وفقاً للظروف البيئية في مدينة اسطنبول في تركيا، تم التركيز في عملية التصميم على إشعاع ضوء النهار اليومي وتحليل البيانات البيئية من خلال نموذج رقمي. تم استخدام برمجتي Rhino 3D و Grasshopper كأداة رقمية للتصميم ومن ثم تم استخدام الملحقات البرمجية Ladybug و Honeybee لإجراء التحليل. تم الحصول على النموذج الرقمي المحسن كما يظهر في الرسوم البيانية الأولى أثناء عملية التحليل البيئي استناداً إلى بيانات طقس مدينة اسطنبول والتي تم الحصول عليها من برمجية Ladybug. بعدها مر النموذج الرقمي بعملية تحليل لتجزئة سطح الواجهة والتي تمت طبق معيار ضوء النهار وأصبح النموذج جاهزاً للطباعة ثلاثية الأبعاد. كنتيجة للدراسة تم تطوير نقاش حول كيفية دمج الألواح الخرسانية مسبقة الصنع في تصميم أسطح بأشكال هندسية معقدة باستخدام تقنيات التصميم الحسابي.

الكلمات المفتاحية: تحليل ضوء النهار، تحليل Ladybug-Honeybee، التجزئة اللوحية، الأسطح المتكيفة، الأسطح المعقدة.

1. Introduction

Due to increasing demand, the number of studies on building-scale sustainable and renewable energy has increased in the world. It has been said that "Special focus should be put on the building envelope design since the local climate requires customized solutions" (Haase *et al.*, 2016). Addressing environmental factors in regional areas in the name of sustainability has encouraged designers to produce location-based solutions. Gagne (2011) advised "To help designers deal with such complex situations, many different tools have been developed for daylighting design and analysis." Today, many design methods have been developed to obtain this kind of data, and innovative workspaces have been described along with computational design tools that have been developed in line with technological changes. "The increase in the quantity of information embedded in the architectural form began in the descriptive dimension, when software borrowed from other disciplines made possible the presentation and alteration of complex forms," Grobman (2013) reported. With the help of these computational design tools, environmental data sources can be obtained through improving plug-ins or specialized software, and designers have started an interactive process in design by converting this data into parameters. Fox *et al.* (2016) reasoned "A biological paradigm of interactive architecture requires not just pragmatic and performance-based

technological understandings, but awareness of aesthetic, conceptual, and philosophical issues relating to humans and the global environment.”

These design methods are often found to be performance-based design approaches. In interactive architecture, a change is seen that emerges from the interaction of environmental data and human data in the result stage of the design model. Konis et al. (2016) highlighted that “Rather than analyzing whether a predetermined building design surpasses or fails a compliance requirement in the late stages of design development, designers are increasingly interested in obtaining rapid and iterative performance feedback on decisions in the early stages of design, where the largest impacts on building performance and occupant comfort are set.” Using the analysis process as a design input in the early design process, predictable simulations and optimizations could be made with computational design tools. Gagne (2011) explained that “One reason why simulation tends to be used more often for analysis of a near-completed design than for early design exploration may be that most simulation tools generally do not provide designers with the means to easily gauge their specific early design options against performance objectives, or with some kind of feedback about how they might change their designs to meet these goals.” By using the analysis process as a design input in the early design process, predictable simulations and optimizations can be achieved using computational design tools. In this context, in this study, in the intersection of the two methodical developments, panelization system is integrated into the design model and are sensitive to daylight, as created in the early design process using the real daylight parameter, which is an important environmental data source. In addition to these situations, differences between solar radiation are produced with techniques different from traditional design methods and structures that are useful in establishing that a structural and formal relationship can be observed. Kalay (1999) noted that “Performance evaluation is intended, therefore, to assess the desirability of the behavior of the confluence of the form, function and context.” Evins et al. (2013) added to this by explaining that “The facade of a building forms a barrier to heat, light and air, and so must be carefully designed in order to achieve high performance.” Further, Andriensis et al. (2014) outlined that “Solar radiation control is performed by identifying an appropriate built shape, passive or active, through dialectic form-finding.” In this study, based on the assumption that the design of the facade according to daylight and wind will affect the entire energy performance of the structure, “the way real environmental data affects the interactive design model” was questioned. “Performance domains,” Kalay (1999) explained, “include energy consumption, lighting (both daylighting and artificial lighting), heat transfer, natural ventilation, mechanical systems, materials, structure, and safety (such as evacuation).” This study concluded with a proposal for a model that could change simultaneously as Yao (2014)

DESIGNING FACADES BASED ON DAYLIGHT PARAMETER: A PROPOSAL FOR THE PRODUCTION OF COMPLEX SURFACE PANELIZATION

proposed: “Movable shading systems were found to reduce the building energy demand while improving indoor thermal and visual comfort conditions significantly.” In the light of the data obtained, we continued our research by focusing on the question “how can we develop a method with computational design tools to increase performance-based energy gain on the facades of buildings during the early design period of environmental inputs”.

Goldman et al. (2014) noted that “The ability to add technical information specific to components, context, and/or place can provide valuable information during the design process.” The steps of the design framework create the analyses, designing a form in order to merge output data with design form, and redesigning the form dependent on the information of changes in sunlight directions. The analyses were conducted as follows: the environmental data were obtained through the EPW.file that was created through the Grasshopper plug-in of Ladybug-Honeybee; temperature data diagrams and wind directions were obtained through the EPW.file; and the distribution of the sunlight directions were based on certain years, months, and days. In the design process, firstly, a mesh surface in grasshopper is achieved; subsequently, the output data from ladybug is merged and integrated with the mesh surface. As a result, the object was wrapped using the color range from warm to cold weather. The design process continued by reconsidering cause of design form of the overlapping fault of the mesh surface. After redesigning the model by reconsidering interactions, a new loft form is designed in order to create panelization which is changeable according to the direction of the sunlight.

2. Related Works

Recently, thanks to developments in computational design tools, several studies have been conducted on façade design using sunpath parameters; Noble and Kensek (1998), Knowles (2003), Zemella and Faraguna (2014) Krietemeyer et al. (2015) and Hosseini et al. (2019) have contributed a great deal in this field. Among them, Hosseini et al. (2019) took the change of the position of the sun as an attraction point and achieved a hierarchical change in the facade modular panelization system. The panelization on the facade changes according to the position of the sun and this provides a gradual transition through closed, semi-closed, and open between the modular panels depending on changes in the sun angle. Figure 1 shows the kinetic facade interaction with sun timing position and occupant position based on the attraction point location and parametric decentralized façade apertures logic resulting in hierarchical modular element configuration (Hosseini, 2019).

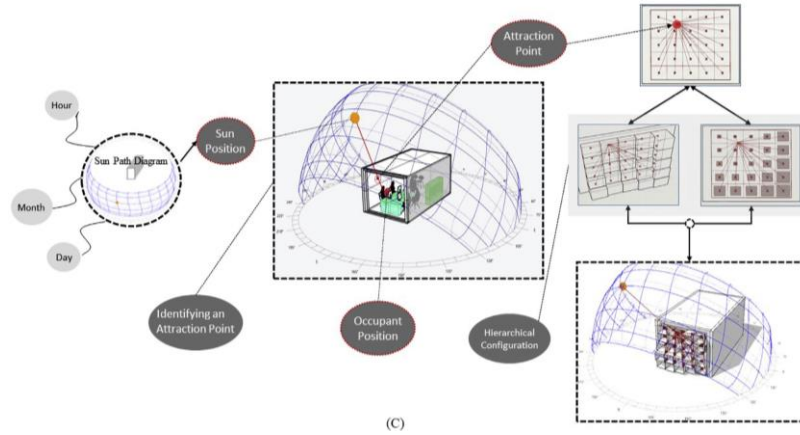

Figure 1. The panelization on the facade

As a result of reviewing studies of adaptive facade panel systems, similar studies led us to define the question of how a complex structure could be designed using panelization change on a facade in Istanbul. Studies on flat surfaces through to complex surfaces were examined within the framework of examples and important reference points were captured for our own study.

3. Materials and Method

In this study, certain data were obtained, such as the latitude and longitude and environmental data of the selected region in Istanbul province. For this purpose, the Grasshopper Ladybug-Honeybee Plug-in and EPW.file were used, and climatic data were obtained.

The Ladybug plug-in analyzed the EPWMAP data and the analysis data. Through the Ladybug, the open weather file and import EPW.file components were processed, and thus, climatic data were obtained. Subsequently, some diagrams were obtained by analyzing the direction, intensity, and temperature of the wind that were obtained from the EPW.data through the Ladybug plug-in. The color range was determined ranging from hot to cold and ranked from the highest degree (orange) to the lowest (blue) (Figure 2).

DESIGNING FACADES BASED ON DAYLIGHT PARAMETER: A PROPOSAL FOR THE PRODUCTION OF COMPLEX SURFACE PANELIZATION

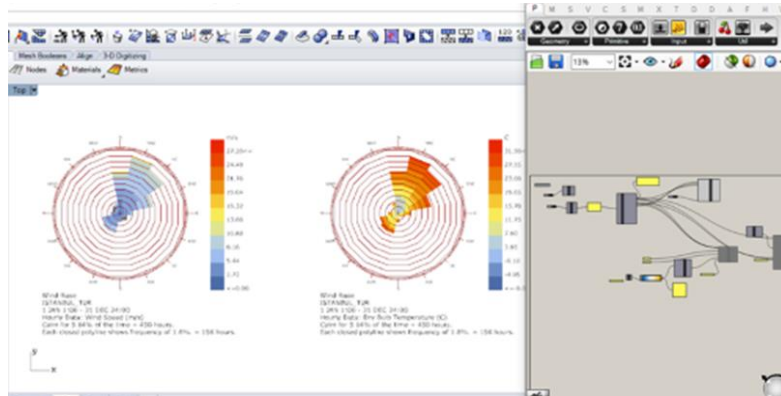

Figure 2. Wind analysis according to the determined temperature range within the determined color range

When working with Ladybug, this analysis process, which affects the design inputs more than any other factor, has been developed interactively with the design model throughout the design process. Owing to the EPW data obtained using Ladybug, the direction and range of daylight could be determined in years, months, days, and hours. Thanks to the Sun-path component of the plug-in, analysis can be performed for these determined months, years, days, and hours. According to the analysis, the range of degrees that should be read in definition was determined as $15 < x < 50$ (Figure 3). The center of the design model was determined using the Sun-path diagrams that were created as the origin. The variability of the Sun-path diagram that will be created later, specifically its scale and the number of the sun vectors, can be adjusted.

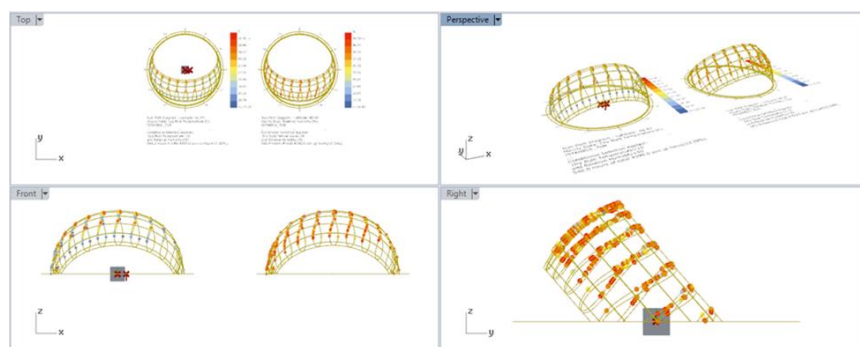

Figure 3. Sun-path diagrams

3.1. CREATING THE PARAMETRIC MODEL THROUGH THE GRASSHOPPER

A model was designed for the integration of daylight analysis with the building model. In the next stage, the first parametric 3D model loft form was created that was planned for panelization. The analysis representation was created directly on the structure form, through the combination of the created loft form and the definition created with Ladybug in accordance with daylight analysis; thus, the mesh surface was obtained. On the surface of the created structure form, it was determined which surfaces receive the majority of the sunlight and which surfaces receive less sunlight. These were color-coded using the same colors as those in the hot/cold color scale in the analyses earlier. The generated Sun-path diagram was arranged to be simpler and to create a single path. Subsequently, it was thought to be more effective in the system, which was supposed to affect panelization as an attractive point or vector. Figure 4 demonstrates the first part of the Grasshopper definition; the output finally gave rise to a color range into the model connection. Then, the color range provided a connection between the facades and the sun by mapping into the facades.

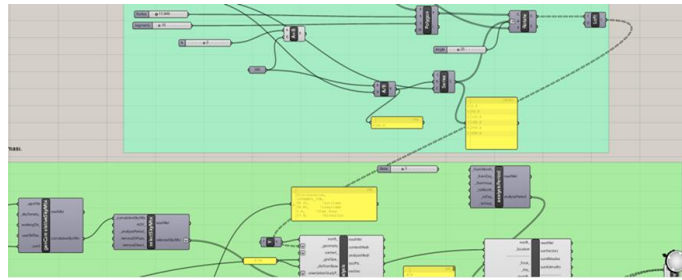

Figure 4. Creation of the Sun-path diagram and creation-determination of the color range, moisture, and daylight analysis definition part 1

Figure 5 demonstrates the analysis of the period created with Ladybug; the output taken from the sun position according to the data coinciding with the month and day hours, and its use as an attractive point on the model. The variability of panels regarding scale and movement was established according to the distance determined from the center point of panelization.

DESIGNING FACADES BASED ON DAYLIGHT PARAMETER: A PROPOSAL FOR THE PRODUCTION OF COMPLEX SURFACE PANELIZATION

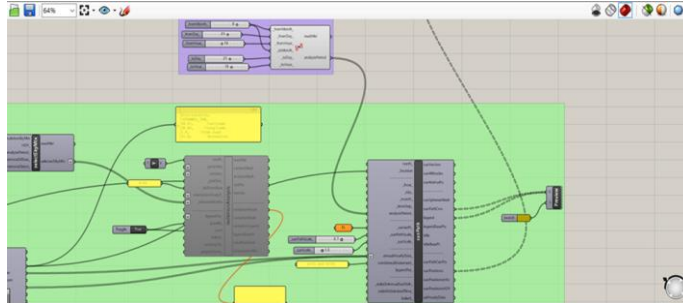

Figure 5. Creation of the sunpath diagram and creation-determination of the color range, moisture, and daylight analysis definition part 2

3.2. DETERMINING THE BEHAVIORS OF THE FACADE COMPONENTS ACCORDING TO THE DAYLIGHT ANALYSIS

The change of each determined panel depended on the distance of the center point from the position the sun was shown as the definition (Figure 6). Since we defined the change using the sun position as the attractive point, as seen in the definition created in Grasshopper, we can see panelization that can vary according to the daylight parameter. We can see that the angle of each panel module changes. The panelization obtained through the loft surface were eventually obtained as merges and then baked (Figure 7).

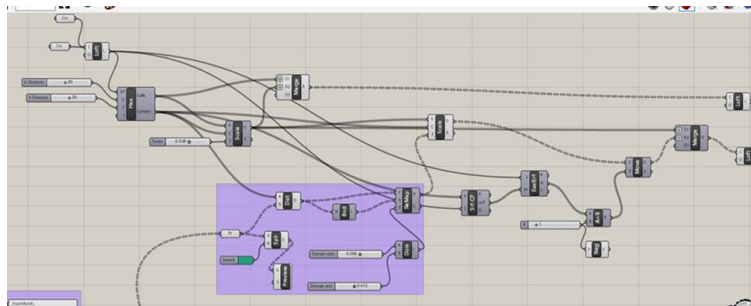

Figure 6. Panelization of the sun position that is used as the attractive point

Two types of solar positions were established in real time, and in this context, more closed panel system angles were created at the points with the most sunlight, while wider-angle panel systems were created to get the daylight on points receiving less daylight. Subsequently, these optimized models were designated as prototypes. The meshes created by the model and baked as a mesh surface were combined, and the prototypes were created by determining a thickness of 1 mm for the 3D print using the “offsetmesh”

command. Figure 8 and Figure 9. demonstrates the baked models in the rapid prototyping process.

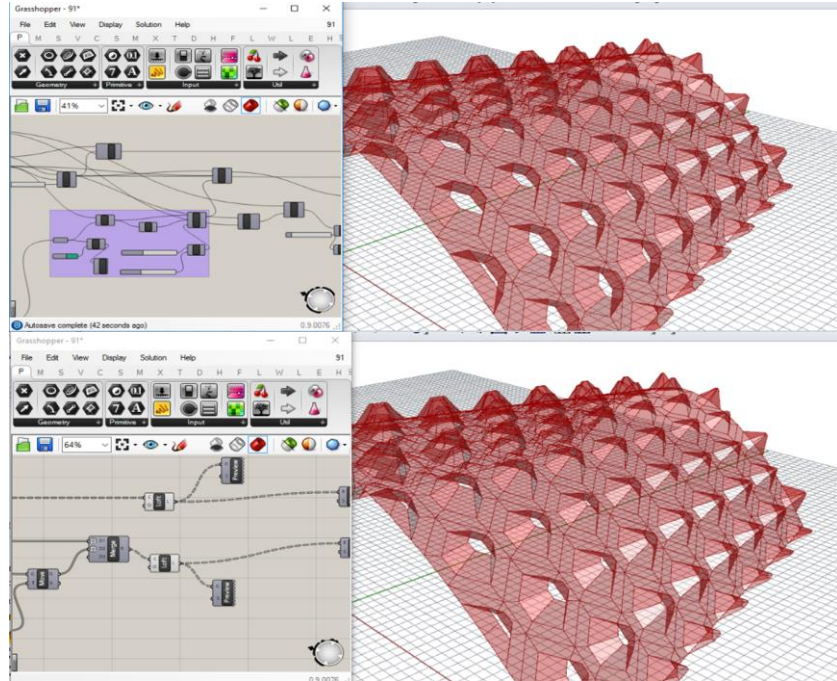

Figure 7. Panelization optimization of the two models created through Grasshopper

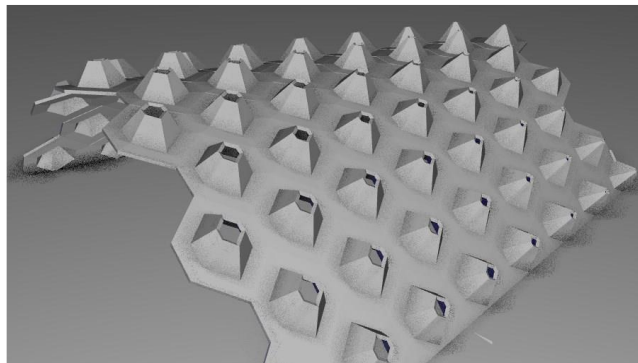

Figure 8. First prototype

DESIGNING FACADES BASED ON DAYLIGHT PARAMETER: A PROPOSAL FOR THE PRODUCTION OF COMPLEX SURFACE PANELIZATION

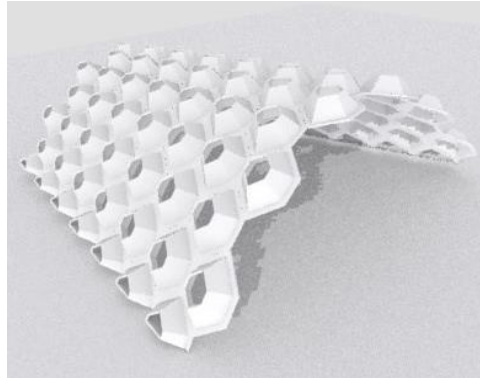

Figure 9. Second prototype

4. Conclusions

In light of the data obtained, we continued our research by focusing on the question “how we can develop a method with computational design tools to increase performance-based energy gain on the facades of buildings during the early design period of environmental inputs”. The way actual environmental data affects the interactive design model was investigated and a model proposal was presented that can change simultaneously. The real-time daylight position was determined according to the data from daylight analysis of the facade panelization, and in this direction, panel systems were created with more closed angles on the points receiving the majority of sunlight, and similarly, panel systems were created with wide angles on the points receiving less sunlight. When evaluating the first model created, it was found that rotating surfaces made it difficult to equally divide the surfaces formed for panelization. Thus, it was understood that the model was not the right choice for panelization due to its form. In the second design model created, a model was generated which was curvilinear but able to respond more clearly to daylight panelization. The change on the hexagonal and evenly partitioned panels created on the form was carried out using the Ladybug-Honeybee plug-in. Subsequently, these prototypes were remodeled using Rhino software in accordance with their original versions. The daylight direction parameter, which was changed during panelization settings using the Ladybug plug-in, forced the working capacity of the program and serious errors occurred from time to time. As the conclusion, it was observed that, owing to these optimized prototypes, a model proposal could be developed that could change simultaneously. In addition, each panel system creates systems that can change/transform according to

different angles. For this reason, concerning the panelization method that can be used in future projects, it was determined that the fabrication process requires certain methods such as one-to-one manufacturing and location-based production. This design significantly outperforms thousands of other traditional solutions. While lighting and ventilation provides positive angles towards the view, other parameters such as privacy are not taken into consideration. Also, there are no detailed solutions for connection points within the design; however, this detail is planned to be resolved in future studies.

References

- Al Bahr Towers, Office & Workplace, AHR, Architects and building consultants, [cited 2020 Oct 20]. Available from: <http://www.ahr-global.com/Al-Bahr-Towers>.
- Evins, R. (2013). A review of computational optimisation methods applied to sustainable building design. *Renewable and sustainable energy reviews*, 22, 230-245.
- Fox, M. (Ed.). (2016). *Interactive architecture: adaptive world*. Chronicle Books.
- Gagne, J. M. L. (2011). *An interactive performance-based expert system for daylighting in architectural design* (Doctoral dissertation, Massachusetts Institute of Technology).
- Goldman, G., & Zarzycki, A. (2014). Smart buildings/smart (er) designers: BIM and the creative design process. *Building information modeling BIM in current and future practices*, 3-16.
- Grobman, Y. J., & Neuman, E. (Eds.). (2013). *Performatism: form and performance in digital architecture*. Routledge.
- Haase, M., & Amato, A. (2006, September). Sustainable facade design for zero energy buildings in the tropics. In *Proceedings of The 23rd Conference on Passive and Low Energy Architecture*, Geneva, Switzerland.
- Hosseini, S. M., Mohammadi, M., & Guerra-Santin, O. (2019). Interactive kinetic facade: Improving visual comfort based on dynamic daylight and occupant's positions by 2D and 3D shape changes. *Building and Environment*, 165, 106396.
- Kalay, Y. E. (1999). Performance-based design. *Automation in construction*, 8(4), 395-409.
- Konis, K., Gamas, A., & Kensek, K. (2016). Passive performance and building form: An optimization framework for early-stage design support. *Solar Energy*, 125, 161-179.
- Knowles, R. L. (2003). The solar envelope: its meaning for energy and buildings. *Energy and buildings*, 35(1), 15-25.
- Krietemeyer, B., Andow, B., & Dyson, A. (2015). A computational design framework supporting human interaction with environmentally-responsive building envelopes. *International Journal of Architectural Computing*, 13(1), 1-24.
- Noble, D., & Kensek, K. (1998). Computer generated solar envelopes in architecture. *The Journal of Architecture*, 3(2), 117-127.
- Reinhart, C. F., Mardaljevic, J., & Rogers, Z. (2006). Dynamic daylight performance metrics for sustainable building design. *Leukos*, 3(1), 7-31.
- Yao, J. An investigation into the impact of movable solar shades on energy, indoor thermal and visual comfort improvements. *Build. Environ.* 2014, 71, 24–32.
- Zemella, G., & Faraguna, A. (2014). *Evolutionary optimisation of facade design: A New approach for the design of building envelopes*. Springer Science & Business Media.
- URL1 <http://www.ladybug.tools/epwmap/>
- URL2 <http://www.food4rhino.com/app/ladybug-honeybee>

A COMPUTATIONAL APPROACH FOR OPTIMIZING THE DAYLIGHTING PERFORMANCE OF EXISTING BUILDINGS

MARIAM M. EL HUSSAINY, MOHAMMED S. MAYHOUB
The American University in Cairo, Egypt
mariam.elhussainy@aucegypt.edu
Al-Azhar University, Cairo, Egypt
msmayhoub@hotmail.com

AND

AHMED EL KORDY
Al-Azhar University, Cairo, Egypt
Ahmed.elkordy@ymail.com

Abstract. Daylighting provision gives a significant contribution to the enhancement of the indoor visual environment and user comfort. This study aims to provide a methodology to assess and optimize daylighting performance in buildings. The paper utilizes simulation techniques for identifying the most efficient daylight performance by incorporating parametric optimization tools to enhance the daylighting performance of existing buildings. The developed workflow includes three consecutive phases. The first examines the daylighting performance of the existing building. The second phase is concerned with daylighting adequacy and the third aims to optimize the quality of light rather than just the quantity through the utilization of a simple shading system to parametrically investigate the effect of using different shading configurations on daylighting performance and to select the optimal solution. A louver system was parameterized according to a predefined process that associates its depth, count and rotation angle while a vertical screen was parametrized according to its scale and tilt angle. To examine the potentials of the proposed multi-stage method, it has been implemented on an office building located in new Cairo, Egypt. The results demonstrate that using the proposed optimization strategy drastically enhanced the Spatial Daylighting Autonomy of the building from 27% to 87% in comparison with the base case. Moreover, the optimum shading solution enhanced the daylighting quality by reducing the glare probability for better visual comfort from 60% to only 14%.

Keywords: Daylighting, Visual comfort, Shading systems, Optimization, Glare.

ملخص. تساهم الإضاءة الطبيعية في تحسين البيئة البصرية داخل المبنى لراحة مستخدميه. تقدم الدراسة طريقة لتقييم وتحسين أداء الإضاءة الطبيعية في المبنى وذلك باستخدام تقنيات المحاكاة للوصول لأفضل أداء بتطبيق برامج انتقاء الحل الأمثل البارامترية. وتضمنت خطة العمل ثلاث مراحل متتالية بدءاً بتقييم الإضاءة الطبيعية (مقياس SDA). ويليهما التغلب على مشاكل نقص أو زيادة الإضاءة الطبيعية من خلال تغيير مادة تشطيب الأسقف والحوائط وتهتم المرحلة الأخيرة بتحسين جودة الإضاءة الطبيعية المعدلة في المرحلة الثانية وذلك بتطوير وتقييم نظام تظليل بسيط مثل كاسرات الضوء الأفقية أو الحاجبات الرأسية بهدف الوصول للحل الأمثل. وقد تم تطبيق الدراسة الحالية على مبنى إداري بالقاهرة الجديدة مما رفع الإضاءة الطبيعية من ٢٧٪ إلى ٨٧٪ (مقياس SDA). كما نجحت الحاجبات الرأسية في تقليل الزغلة من ٦٠٪ إلى ١٤٪.

الكلمات المفتاحية: الإضاءة الطبيعية، الراحة البصرية، نظام التظليل، أداة إنتقاء الحل الأمثل، الزغلة البصرية.

1. Introduction

Incorporating daylight simulation methods in the design process has rapidly developed to use daylight simulation as a driven tool for design to reach maximum daylight quality. They were utilized to optimize the whole building design (Fang et al., 2019) (Toutou et al., 2018) (Li et al., 2013) (Suyoto, et al., 2015) or only individual components, such as roofs (Turrin et al., 2012), skylights (El-Abd et al., 2018) (Al-Obaidi et al., 2017) (Acosta et al., 2012) (Chel et al., 2010) or fenestrations (El Daly, 2014). In a recent study, Gonzalez and Fiorito carried out an optimization design of the shading devices in an office space in Sydney. Results showed that the useful daylight illuminance (UDI) maximized between 2.5 m and 3.5m away from windows and drastically reduced farther away from the windows. Investigations revealed that shading systems significantly reduced the illuminance levels only in the first few meters from the windows, but they helped obtaining more uniform illuminance levels (González et al., 2015).

Many buildings in Egypt have ignored their climatic conditions, considering that Egypt lies in the hot arid region by, extending the use of glazing that causes unwanted glare and increase cooling loads (Reinhart, 2001). This triggered the researchers to develop workflows that utilizes simulations software to guide the designers towards designs that adapts with the climate rather than neglecting its impact.

The previous studies focused on enhancing the daylighting performance of a one-room-study-model, while this study aims at retrofitting an existing building in urban context to prove the sufficiency of the proposed workflow and obtain applicable results. Moreover, this workflow can be used in the preliminary design phase to evaluate the daylighting performance of the proposed alternatives and guide the designers towards better decisions.

Daylighting simulation has been carried out with the use of Rhinoceros/Grasshopper to evaluate the daylighting performance of an open office

A COMPUTATIONAL APPROACH FOR OPTIMIZING THE DAYLIGHTING PERFORMANCE OF EXISTING BUILDINGS

space in an office building located in New Cairo, Egypt. The results shall determine whether the daylighting provision is sufficient or not and identify the associated problems. The study will show how these problems can be approached using different optimization techniques to enhance the qualitative and quantitative properties of the space lighting.

2. Daylighting Evaluation Criteria

2.1 DAYLIGHT AVAILABILITY

It divides the space area into three zones and gives a warning when daylight exceeds the maximum threshold for more than 5% of the occupied hours (Table 1).

TABLE 1. Daylighting Availability threshold

Daylight Availability	Threshold	Occupied Hours
Daylit	300 to 3000 lx	For at least 50% of the occupied hours
Partially- Daylit	300 lx	Less than 50% of the occupied hours
Over-lit	<3000 lx	More than 5% of the occupied hours

2.2 SPATIAL DAYLIGHT AUTONOMY

Spatial Daylight Autonomy (sDA) describes how much of a space receives sufficient daylight. It represents the percentage of floor area having 300 lx for at least 50% of the occupied hours (8:00 am – 6:00 pm in this study) throughout the year. A preferred minimum percentage of 75% of room area for sDA is recommended (U.S. Green Building Council, 2009; Wagdy et al., 2015). Similarly, the preferable daylighting conditions set by the IES for sDA 300/50% should be equal or more than 75% of the room area.

3. Methodology

A simulation-based design workflow was developed in Grasshopper capable of evaluating the daylighting performance of the building. Each phase of the workflow consists of multiple steps that must be completed to set up and run the optimizations. The existing building was modelled and daylighting performance simulations were performed and evaluated based on the previously mentioned daylighting performance metrics. Then, the daylighting issues of the building were identified. The solution procedure, according to the developed workflow, starts with materials changes for the most effective elements to enhance the daylight distribution. This is followed by writing a parametric script of the fenestration system geometry parameters that are set by the designer, which can be adjusted and run again to compare differences in performance. Repeating the process many times are intended to produce an improvement in the building's daylighting performance.

The remarkable differences between the proposed approach and the previous studies are as follow:

- It was examined on an existing building not a study model.
- It was utilized in a whole building level and not on a specific room model like other studies (Fukuda et al., 2016).
- It improved the building performance with minimal modifications.
- It optimized the daylighting for all building facades not only on a southern facade like other studies (Wagdy et al., 2015).
- The simulation included the surrounding context, while in other attempts there were no surroundings since they were applied on study models.

3.1 SITE ANALYSIS

New Cairo, a newly developed urban settlement around Cairo (30° N, 31° E), has been selected as a study area due to its popularity and fast growing ratio. The study area is a linear raw of buildings that extends about 3 km along the southern 90th Street. A considerable number of corporations and institutions have recently established new headquarters or main branches in the commercial spine. Most of these buildings' facades include vast areas of glass ignoring their climatic region (Mayhoub et al., 2015) (Figure 1).



Figure 1. The site layout of the case study building, actual building shot and 3D model

A glazed-façade-office building has been selected as the study model to evaluate its daylighting performance and apply the proposed optimization technique to enhance the occupants' visual comfort, increase workers' productivity and satisfaction. The building is surrounded by two buildings from both sides with almost the same height, while on the back there is an empty plot that is expected to be built any time. This context shall affect the simulation since surrounding

A COMPUTATIONAL APPROACH FOR OPTIMIZING THE DAYLIGHTING PERFORMANCE OF EXISTING BUILDINGS

buildings can cast shadow over the chosen building, or even reflect the sunlight and cause glare.

3.2 BUILDING THE 3D MODEL

The building floor plans were modelled in addition to the outer skin with its curtain walls as measured from the actual building. Different studies have emphasized the influence of the surrounding context on the daylight availability and recommended considering it to secure adequate daylight exposure for the occupants (Kim et al., 2014). Thus, the surrounding context has been modelled with its actual height and materials. Each building element was defined and assigned material in Grasshopper according to its function. The grid size was set along at a 0.70m height from the floor finish level.

3.3 THE SIMULATION-BASED WORKFLOW

The simulation went through three consequent phases illustrated in the section below:

3.3.1 Phase One: Evaluation process of the existing daylighting performance

The building WWR was modelled according to the original building to evaluate its daylighting performance. The materials reflectance values were set according to the recommended reflectance values for this function (Table 2).

TABLE 2. Original building parameters

Building Parameters	Attributes	
WWR	North facade	Ratio = 50%
	South facade	Ratio = 80%
	East facade	Ratio = 55%
	West facade	Ratio = 45%
Material	Walls	Reflectance = 50%
	Floors	Reflectance = 20%
	Ceiling	Reflectance = 70%
	Glazing	Visual Transmittance = 80%

3.3.2 Phase Two: Enhancing the daylighting quantitative performance

The LEED rating system requires an evenly distributed illuminance of 300–500 lx (U.S. Green Building Council, 2009). The simulated illuminance levels show a trend of excessive provision of daylight near the window and lack of provision towards the rear of the room. As the distance from the window increases, the space became more dependent on the light reflected from the surrounding surfaces. However, most of the time, the walls, floors and furniture are of low reflectance, thus making the

rear part appears gloomy and too dark to perform visual tasks. The stark contrast between the bright windows and dark rear area is also likely to create discomfort glare. As a result, occupants tend to pull down the curtains and switch on electrical lighting. This situation is commonly found in office spaces. The prolonged usage of electrical lighting will inevitably result in high-energy consumption. The application of advanced daylight systems can reduce the energy consumption in buildings (Wittkopf et al., 2006).

Light and materials are mutually dependent on each other. Materials are key to understanding light in architecture because they directly affect the quantity and the quality of the light. Specular materials, such as glossy finishes, have highly reflective ratios but might reflect the image of the light source causing disturbing glare. Matte surfaces, such as natural stone and plaster, reflect light in all directions producing diffuse homogeneous illumination.

There are several ways in which an architect can optimize the design and building orientation to capture natural light, which is not always enough, necessitating the help of a building's interior materials to introduce light further inside. The most important interior light-reflecting surface is the ceiling (Spellman, 2018). Tilting the ceiling plane towards the daylighting source increases the daylight reflected from this surface, which eventually enhances the daylighting distribution. Sidewalls and floor surfaces have less impact on reflecting daylight in the space (Spellman, 2018). For example, using a ceiling with a light reflection of 87% can draw light 11% further into a space than using regular gypsum tiles (Rockfon, 2013).

Therefore, for the case study, to have deeper penetration as well as light diffusion in the building core without making major changes to the existing design, the following solutions were proposed:

- a) Changing the wall material to white glossy paint with 60% reflectance.
- b) Replacing the regular gypsum board ceiling with a high reflective ceiling (90%) that could be stone wool ceiling tiles with a super white matt finish (Rockfon, 2013). This idea is inspired from interior reflective light shelves as they are fixed above window openings to draw the light into the space. However light shelves increase the UDI values mainly in only the first six meters from the windows. Thus, this solution cannot be generalized in the case of deep plan buildings (Berardi, 2016). Deep plan buildings (floor plans greater than 10m depth) have become a common practice in middle and high-rise office building design for economic reasons and spatial requirements of the workplace. The deep core areas of these buildings cannot be naturally illuminated by side windows, and depend entirely on artificial lighting (Hansen et al., 2003). Therefore, the high reflective ceiling is proposed to better bounce the daylight around the space and reduce extreme brightness contrast, which is the main cause of glare (Spellman, 2018), while discharging the daylight to the deep and gloomy zones. Thus, the demand for electrical lighting will be reduced. As for the suggested reflectance values, they have obtained from the Whole Building

A COMPUTATIONAL APPROACH FOR OPTIMIZING THE DAYLIGHTING PERFORMANCE OF EXISTING BUILDINGS

Design Guide (WBDG) to keep ceiling reflectance over 80%, walls over 50%, and floors around 20%.

c) Adding a curtain wall to the inner western façade with WWR of 75%, as it does not contain any openings (Figure 2).

3.3.3 Phase Three: Optimizing the daylight qualitative performance

The aim of an efficient daylighting design is not only to provide the required illuminance levels, but also to maintain a comfortable atmosphere. Therefore, after achieving the optimum daylighting quantity in the second phase, a shading system may be needed to reduce the harshness of direct sunlight while allowing indirect sunlight penetration. The WBDG recommends avoiding direct sunlight beam and daylight filtration through, curtains, louvers or vertical screens that should help in distributing light (Gregg D. Ander, 2012). In a previous study, the effectiveness of solar screens was studied through different screen configurations for a living space model located in a desert climate. Recommendations were given for each orientation regarding adding light shelves, changing rotation angle, screen height and aspect ratio (Sabry et al., 2012).

The current study will examine two different shading systems to optimize the quality of light. Horizontal louvers and vertical screens were selected because they are the most common solutions used to overcome the daylighting issues.

3.3.3.1 External louvers system

Three external louver system configurations have been investigated; horizontal, vertical and combined. Different parameters were tested, as presented in Table 2, to know which configuration performs better. The louver system was recently adopted by (Wagdy et al., 2015) to reach the best configuration that achieves optimum daylighting performance in the desert climate and to reach a balance between daylighting adequacy and energy consumption (Wagdy et al., 2016). Another study developed a combined louver system to reach a balance between daylighting availability, prevention of glare, and energy conservation. The results proved that horizontal louvers were successful in the north and south orientation while the vertical ones performed better in the east and west facades (Sabry et al., 2014). A perforated curved louver system to control the visual comfort of a glazed office space located in four different climates was the scope of study of another research. The results demonstrated how each location was controlled by a specific louver parameter to reach the main goal (Uribe et al., 2019)

The depth ratio of the louvers was set to start from 0.50m as smaller depths showed insufficiency in preventing glare (Wagdy et al., 2015). While the parameter louver rotation was added in order to test the efficiency of using combined shading systems (horizontal and vertical) especially in the eastern and western facades.

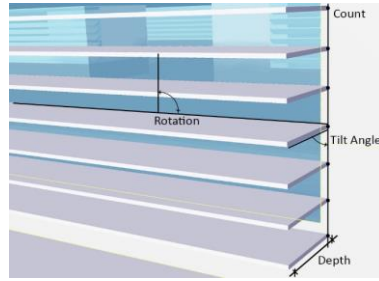

Figure 2. Louver system parameters

TABLE 3. The fixed and variable parameters of the used shading device

Parameters	Attributes
Material reflectance	80%
Depth	From 0.50 to 0.95 with an increment of 0.05
Tilt Angle	From -20° to 20° with an increment of 10°
Louver Rotation	Either 0° (Horizontal) or 90° (Vertical)
Louver Count	From 2 to 6 with an increment of 1

3.3.3.2 Vertical Screen system

Although perforated panels already exist in the market and have been used as vertical screens in buildings, they have been usually utilized for aesthetic purposes rather than functional, such that intended in this research, or they respond to standard solutions with perforations that have no relation to the indoor comfort needs. The selected perforated screen is mainly a cladding made up of rhomboid textile awnings and inserted rigid membranes supported by a tensile-stressed steel cable structure. It acts as sunshades to achieve maximum shading, but also to allow possible views from the inside from the perforations between the screen panel and the structure system.

The shape of the screen was selected due to its simplicity, easy to manipulate parameters that can drastically affect the results with a minor move in the grasshopper slider component. Another important factor is that despite it is considered static, it offers the occupants the option of adjusting the tilt angle according to their preference. Furthermore, the screen parameters can be easily adjusted according to each building needs after running an optimization process to determine these values. On the other hand, its simple, light structure makes it applicable to different types of buildings. Similar designs were used in King Fahd National Library in Riyadh, Saudi Arabia and Hazza Bin Zayed Stadium in Abu Dhabi, UAE (Figure 3).

The simulation was carried out to determine the size of the diamond shape panel and the tilt angle. The simulation parameters are shown in Table 3. The scale factor of the screen means the solid to void ratio according to the size of the panel to the

A COMPUTATIONAL APPROACH FOR OPTIMIZING THE DAYLIGHTING PERFORMANCE OF EXISTING BUILDINGS

1.00m*1.00m skeleton system. Therefore, the smaller the scale factor is, the more the direct daylight penetrates (Figure 4).

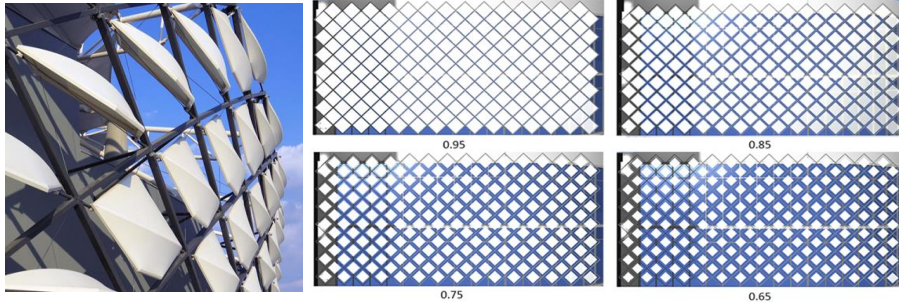

Figure 3. Bin Zayed Stadium Figure 4. Different scale factors of the screen size

TABLE 3. Fixed and variable parameters of the used screen

Parameters	Attributes	
Window	WWR	Fixed as in the base case model
	Window Material	Metal Diffuse
	Glazing	Double clear pane (VT=80%)
Screen	Scale	From 0.50 to 0.95 with an increment of 0.05
	Tilt Angle	From 90° to -90° with an increment of 15°

4. Results

4.1 DAYLIGHTING SIMULATION OF THE BASE CASE

The simulation results show that the partially daylit areas reached 50%, while the over-lit spaces that occurred mainly beside the openings reached 40%, which causes a high amount of glare. The sDA achieved only 27%, which strongly indicates that the majority of the office space has insufficient illuminance level (Figure 5).

4.2 ENHANCING THE DAYLIGHTING QUANTITATIVE PERFORMANCE

Changing the wall and ceiling materials and the addition of a daylighting source in the west façade significantly enhanced the sDA from 27% to 87%, which considerably solves the issue of the insufficient lighting level (Figure 5). Nevertheless, this increase in daylight consequently caused an increase in the glare level from 40% to 60%.

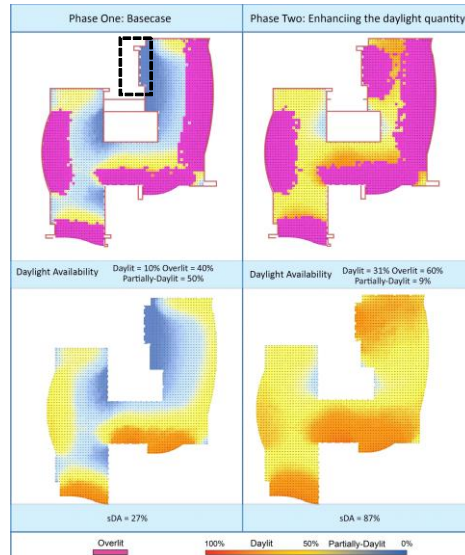

Figure 5. Comparison between the simulation of the 3rd floor before and after enhancing

4.3 ENHANCING THE DAYLIGHTING QUALITATIVE PERFORMANCE

4.3.1 Louvers utilization

Different louver types (i.e. horizontal, vertical and combined) and different louvers parameters (i.e. depth, count, and tilt angle) have been tested. Among 450 trials, Figure 6 shows the cases that achieved the best results and Table 4 presents their parameters.

Case A achieved the highest sDA (77%), but accompanied by an over-lit percentage of 31%, which would certainly affect the quality of daylight and the occupants' visual comfort level. Case B achieved 68% sDA, which is slightly lower than the LEED acceptable level. However, the corresponding over-lit percentage reached 22%, since there is a reversed correlation between the sDA and over-lit percentage. In Case C and D, the sDA reached 63% and 61%, while the over-lit percentage was 25% and 26% respectively.

The achieved results show that the utilization of the louver system has the potential to significantly increase the illuminance level, but combined with glare hazard. The target was to find out a configuration that allows the best achievable sDA, while preventing unwanted glare. The louver approach did not effectively achieve the desired compromise between sufficient daylighting and the minimization of the combined glare.

A COMPUTATIONAL APPROACH FOR OPTIMIZING THE DAYLIGHTING PERFORMANCE OF EXISTING BUILDINGS

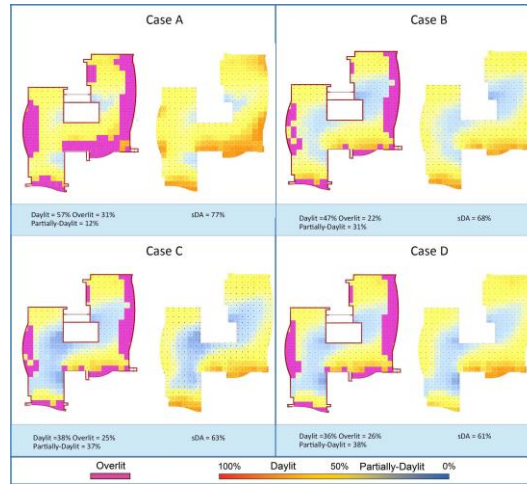

Figure 6. Simulation results of the 3rd floor using louvers with different parameters.

TABLE 4. The louver parameters of the best cases

Screen Parameters	Façade	Case A	Case B	Case C	Case D
Depth	South	0.65	0.80	0.95	0.95
	East	0.65	0.75	0.90	0.90
	West	0.50	0.85	0.90	0.95
	Inner East	0.65	0.65	0.70	0.95
	Inner West	0.50	0.60	0.75	0.95
Tilt Angle	South	0°	-30°	60°	-30°
	East	-15°	-60°	30°	45°
	West	-15°	60°	-30°	-30°
	Inner East	-15°	-30°	45°	30°
	Inner West	-15°	45°	0°	15°
Louver Rotation	South	0°	0°	0°	90°
	East	0°	90°	90°	0°
	West	0°	0°	90°	0°
	Inner East	0°	0°	0°	90°
	Inner West	0°	0°	90°	0°
Louver Count	South	4	3	4	3
	East	3	3	4	4
	West	4	2	2	3
	Inner East	6	4	5	4
	Inner West	5	4	6	3

4.3.1 Vertical Screen utilization

The results show that the utilization of the vertical screen achieved much better results with sDA percentage of 78% and over-lit percentage as low as 14%.

Table 5 shows the optimized screen parameters concluded from the optimization process. Figures 7 & 8 show a comprehensive comparison between the performances of the base case in phase one, phase two optimization results and the results of the utilization of the louvers and vertical screen in phase three. The optimized screen was very effective in reducing the glare probability, which is an

important factor to enhance the visual comfort of users while providing sufficient daylighting level. In addition, the screen perforations maintained a percentage of transparency that allows the visual contact between the inside and the outside of the building.

5. Discussion

The proposed method demonstrated a potential to enhance daylighting performance with minimal modifications to the building form, which makes it applicable to both new and existing buildings. The daylighting analysis of the existing building showed a lack of adequate lighting, as it reaches 27% in terms of sDA. In addition, the over-lit area count for 40% causing

uncomfortable visual environment due to the excessive presence of the direct sunlight because of having 80% glazing in the south façade, 60% in the northern one, 55% in the eastern façade and 45% in the western facade. This means that there is a non-uniform daylighting distribution due to the contrast between direct sunlight near the windows and dark areas at the core of the building. Therefore, with the intention to maintain the original design, very limited modifications have been suggested to enhance the building performance. According to previous publications, using materials with high light reflection and the increase of light diffusion can increase the level of daylighting availability in a particular space. To avoid disturbing glare, it is also recommended to use products with a matt surface, as it helps nurture visual comfort. So, the modifications were resembled in using high reflective ceiling tiles as well as adding an opening to the inner western façade. Although these modifications succeeded in increasing the sDA percentage to 80%, this drastic increase was accompanied by excessive glare. Therefore, the third phase proposed two different types of shading devices to diminish the glare problem while maintaining the sDA percentage as high as possible. The first shading system was louvers with variable depth, count, tilt angle and rotation. The optimization managed to increase the sDA by 50%, which reached a LEED acceptable level. However, it was not able to optimize the quality of light as required due to the glare percentage that reached 31%. From a broader perspective, most of the cases that achieved minimum glare, obtained sDA percentage below the accepted level. While the ones that maintained adequate sDA did not decrease the glare as required.

It was also concluded that the louver depth ratio was the most dominant parameter in controlling the amount of glare. However, depth ratios smaller than 0.55 m was found to be insufficient in preventing glare and the downwards tilt angles was found to have a positive impact in blocking the direct light. On the contrary, the upwards tilt angles allowed direct sunlight beams. On the other hand, the louver count had

TABLE 5. The optimum screen parameters for the base case scenario.

Screen Parameters	Facade	Optimum Solution
Scale	South Right	0.70
	South Left	0.85
	Middle South	0.60
	East	0.75
	West	0.70
	Inner West	0.60
Tilt Angle	All Facades	0°

A COMPUTATIONAL APPROACH FOR OPTIMIZING THE DAYLIGHTING PERFORMANCE OF EXISTING BUILDINGS

neither negative nor positive impacts on the daylight distribution, which agrees with the conclusion of a previous study, investigated the louvers' impact on the lighting performance of a south-oriented generic classroom (Wagdy et al., 2015). It is found that louvers count has no remarkable influence, while louver's depth ratio contributed to blocking direct sunlight. Moreover, the study reported that solutions that met the predefined criteria were attained in large WWRs with downwards tilted angles. Another research attempt that studied the effect of sun breakers cut off angles, inclination angles and slats number on daylighting performance in a south-facing office façade concluded that changing the number of slats had no significant effect on daylighting measure (Gadelhak et al., 2013).

The vertical screen shading system showed the ability to maintain a sufficient lighting level of around 78%, while reducing the glare by 46%. It was observed that the screen tilt angle had a negative impact on daylighting, as it either allowed direct sunlight penetration or blocked the light completely (Figure 7).

On the other hand, the screen scale had a greater impact, as solutions that met the predefined criteria were attained in scale factors greater than 60%, while smaller scales were considered useless in blocking glare. In a similar approach, Thanyalak and Kyosuke aimed to find the optimum perforations scale of a double skin south oriented façade. They found that the average scale factor that achieved optimum daylight was 80% solid to void perforations, while the number goes up in summer to reach almost 90% and decreases in winter to reach 70% (Srisamranrungruang et al., 2020).

Comparison between these results and the optimum scale factor in the current study reveals that the numbers are within the same range, as it is concluded that the optimum scale factor of the south façade is between 75% and 85%.

To sum up, the first attempt to optimize the quality of daylight using louvers did not achieve the required balance. Meanwhile, the second attempt using a vertical screen achieved much better results as shown in (Figure 8).

In conclusion, the findings prove that solar screens can drastically improve the daylight distribution in the spaces. Meanwhile, the glare phenomenon was eliminated in the East, West and South orientations.

This workflow can be generalized in any type of buildings after evaluating the building performance and tailoring the parameters according to each condition. Although the louver system was not able to reach satisfying results, this does not mean that it would be insufficient in all cases, because each building has its own conditions, such as location, context and WWR. The same workflow could be applied on a building located in high-density urban environment where buildings are surrounded by other tall buildings, so the resulting parameters could have a smaller depth ratio in the louver system or larger scale in the screen system to allow more light.

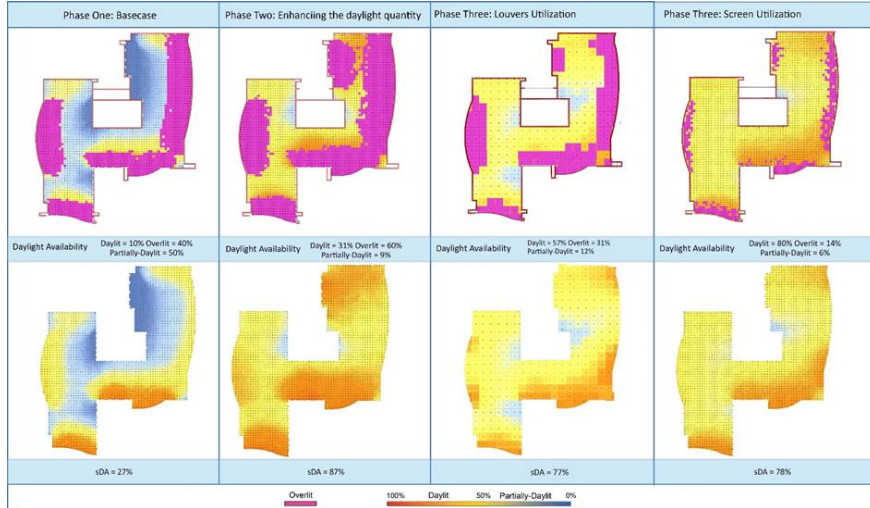

Figure 7. Comparison between phase one, two and three

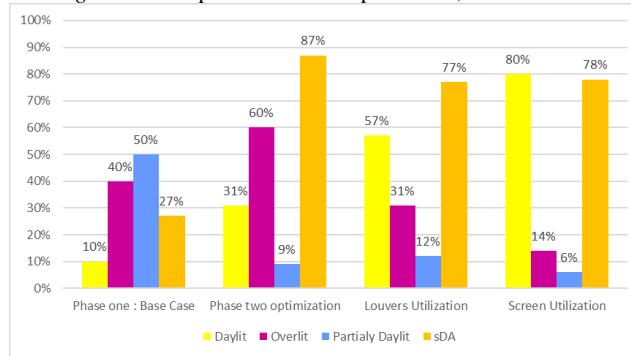

Figure 8. A bar chart that compares between the base case and the two phases of optimization

6. Conclusion

The current study proposes an optimization strategy that has the potential to improve the daylighting performance of buildings as well as enhance the experience of the users through achieving a better quality of daylighting. The workflow consists of three phases that include analysing the existing building performance, modifying indoor finishing materials and using proper shading devices. An office building located in new Cairo was studied to examine the proposed method. The results demonstrated that the original building had insufficient lighting issues. Thus, the optimization process was carried out to figure out the optimum modifications and shading strategies that achieve better lighting quantity and quality. The results also demonstrated that the building suffered from lack of lighting due to the core depth that exceeded 10 m while the glazed facades caused excessive daylight beside the windows that was all resolved by the reflective ceiling for more homogeneous light distribution along with the vertical screen to block the direct light.

A COMPUTATIONAL APPROACH FOR OPTIMIZING THE DAYLIGHTING PERFORMANCE OF EXISTING BUILDINGS

The study proves that improvements in the daylighting performance could be achieved when using the right methodology and tools. In other words, this workflow has the ability to control many design parameters for each type of building geometry at any level of detail. It uses the analysed data, evaluates them, and guides the architect towards the optimum solution. The proposed technique becomes an effective way to enhance the daylight illumination quality. Although the assessment and optimization process is preferably done in the early design phase, the paper proved that retrofitting measures could still enhance daylighting performance. Ultimately, this workflow could be upgraded in the future to involve different environmental factors, such as solar radiation, wind and ventilation, energy demand, thermal losses and more. Some conflicts may occur, but the proposed approach will help to trade-off and direct the final solution towards the main design objective, while taking into account the overall performance of the building.

References

- El Daly, H., 2014: Automated fenestration allocation as complying with LEED rating system. *Alexandria Engineering Journal.*, 53, 883–890.
- Elghazi, Y.; Wagdy, A.; Mohamed, S.; Hassan, A., 2014: Daylighting Driven Design : Optimizing Kaleidocycle Facade for Hot Arid Climate. *German-Austrian IBPSA Conference.*, 314–321.
- Gadelhak, M.; Aly, M.; Sabry, H., 2013: High performance facades: The effect of sun breakers on daylighting performance and energy consumption in south oriented office spaces. *AEI 2013: Building Solutions for Architectural Engineering - Proceedings of the 2013 Architectural Engineering National Conference.*, 776–784.
- Gregg D. Ander, F., 2012: *Whole Building Design Guide. Daylighting.*
- HBRC, 2009: *The Egyptian Code for Energy Efficiency commercial Building.*
- Lavin, C.; Fiorito, F., 2017: Optimization of an External Perforated Screen for Improved Daylighting and Thermal Performance of an Office Space. *Procedia Engineering.*, 180, 571–581.
- Sabry, H.; Sherif, A.; Gadelhak, M., 2012: Utilization of combined daylighting techniques for enhancement of natural lighting distribution in clear-sky residential desert buildings. *Proceedings - 28th International PLEA Conference on Sustainable Architecture + Urban Design: Opportunities, Limits and Needs - Towards an Environmentally Responsible Architecture, PLEA 2012.*
- Spellman, F. R., 2018: *Environmental Engineering Dictionary.*
- Srisamranrungruang, T.; Hiyama, K., 2020: Balancing of natural ventilation, daylight, thermal effect for a building with double-skin perforated façade. *Energy and Buildings.*, 210.

PARAMETRIC SIMULATION AND SENSITIVITY OF LIGHT SHELF ON DAYLIGHTING AND SHADING

Light Shelf Performance Map

MINA ISHAC
German University in Cairo
mina.ishac@guc.edu.eg

Abstract. The design of the optimal light shelf to maximize daylighting performance in a space is governed by many factors which change simultaneously. The dynamic characteristics inherited in such factors range from: temporal changes of daylight over the course of the year and the change of daylighting conditions from one country to another to variable factors that are informed by the design process and functional programmatic use. The lack of a comprehensive study that links all these factors together to find out the near-optimal light shelf adapted to different conditions and locations, and moreover devise performance map that could be used to predict the performance. Given the constraints of light shelf's dimensions endorsed by previous literature, this paper develops a map to predict daylighting in unexamined geographical locations, based on annual daylight profile in 3 cities (Stockholm, Cairo, and Nairobi) using quadratic regression method. The aim is to find the approximate dimensions for the needed near-optimal light shelf that optimizes daylighting and shading in any location. The paper uses a parametric approach to simulate daylighting using Radiance, in which 11 models of light shelves will be varied in a hypothetical typical room. The studied variables are: geographical latitude and their respective climatic conditions, and window-to-wall ratio (20-60%). The examined aspects: seasonal hourly illuminance, annual daylighting using UDI and DAV, average annual uniformity, and control of direct sunlight. The data are analyzed in MATLAB to present plot radar diagrams which can provide insights into the performance sensitivities of the models, with respect to daylighting. The performance curves are a preliminary design tool, that is based on approximation of dynamic daylighting.

Keywords: *daylighting; light shelf; parametric simulation; Useful daylighting illuminance; daylighting availability.*

PARAMETRIC SIMULATION AND SENSITIVITY OF LIGHT SHELF ON DAYLIGHTING AND SHADING: LIGHT SHELF PERFORMANCE MAP

ملخص. إن تصميم الكاسرات الشمسية المثلى، المعروفة بـ"Light Shelf"، التي تسعى لتحقيق أقصى قدر من الإضاءة الطبيعية عادةً ما يخضع إلى العديد من العوامل التي تتغير في آن واحد. ومن ثم، تتعدد وتتغير العوامل المؤثرة ومنها التغيرات الزمنية والديناميكية للضوء الطبيعي على مدار العام وتغير حالة الإضاءة الطبيعية من بلد إلى آخر إلى عدة عوامل أخرى تتغير تبعاً للعملية التصميمية والبرنامج الوظيفي للفراغ الدراسي. وتسعى هذه الدراسة إلى ربط كل هذه العوامل معاً للوصول إلى أمثل الحلول لتحسين الإضاءة الطبيعية والذي يتكيف مع طبيعة مناخ المدن المختلفة، علاوةً على وضع خريطة أداء يمكن استخدامها للتنبؤ بأداء الكاسرات الشمسية المستخدمة في المواقع الجغرافية العديدة وهذا أخذاً في الاعتبار محددات الكاسرات من الدراسات السابقة. تم تصميم هذه الخريطة بناءً على بيانات الإضاءة الطبيعية السنوية في ثلاث مدن: ستوكهولم والقاهرة ونيروبي وهذا باستخدام طريقة خطوط الاتجاه 'Regression' التريبيعية. ومن أجل الوصول إلى هذا الهدف، يتم محاكاة 11 نوع من الكاسرات الشمسية في فصل دراسي نموذجي وأفتراضي باستخدام برنامج المحاكاة 'Radiance'. ويتم دراسة تأثير تغير العوامل العديدة على الإضاءة، ومنها: الموقع الجغرافي والظروف المناخية الخاصة به، ونسبة الفتحات. ومن جهة تقييم النتائج، يتم دراسة الإضاءة اللحظية والموسمية والسنوية UDI و DAV والتحكم في الإضاءة المباشرة بالإظلال. ويتم تحليل البيانات باستخدام برنامج MATLAB لحساب قيم الإضاءة المختلفة ورسم منحنيات ومخططات الرادار التي تسجل حسابات أداء النماذج المختلفة. ومن الجدير بالذكر أيضاً أن هذه المنحنيات ما هي إلا أداة مبدئية لتصميم الكاسرات، والتي تقوم على تقريب الحسابات الديناميكية للضوء الطبيعي المرتبطة بالأجواء المناخية الحقيقية.

الكلمات المفتاحية: الإضاءة الطبيعية، Light Shelf، المحاكاة الرقمية، الإضاءة الطبيعية المفيدة، وفرة الإضاءة الطبيعية.

1. Daylighting Availability

Daylighting is continuously changing temporally and spatially over many geographical locations. The variations in daylighting predict an impact on the lighting quality and quantity in the built environment and occupants' comfort. As our planet Earth rotates around its axis, the day and night changes simultaneously. Countries lie on same latitudes, and with different longitude, have the same daylight hours (Danilenko et al. 2000). The study by Ibrahim, Hayman, and Hyde (2009) carried out simulations on daylighting to study how daylighting changes as the latitude changes, and its effect on the rule of thumb of the window to floor ratio.

Depending on the time of the year, prevailing climate and sky cloudiness (Arnesen, Kolas and Matusiak 2011), availability of daylighting will change. At the equator (latitude 0°) day length is constant per the year and will last approximately 12 hours. As we move up/down to the north or south, daylight vary depending on the time of the year (Hausladen, Liedl and Saldanha 2011; Ruck et al 2000).

2. Daylighting Performance and Objectives

Daylighting has profound benefits to the human eye and can improve the performance of students in schools (Heschong et al. 1999; Baker 2012) when it is provided in reasonable quantity and quality. Thus, daylighting objectives have been formulated in schools in Caldas and Norford (2001) to:

1. Shade direct sunlight and reduce overlit light (above 2000 lux).
2. Increase useful daylight levels (500-2000 lux according to IESNA 2000, Cellai et al 2014) in the middle of the room.
3. Increase useful daylight levels at the back of the room.
4. Improve distribution of light across the room (increase uniformity).

Useful daylighting illuminance UDI and Daylighting Availability DAV are a climatic based dynamic metrics which incorporate local climate, orientations, and occupancy (Reinhart and Fitz 2006; Mardaljevic 2000).

3. Light Shelf as a Daylighting Redirecting Device

As the need for daylighting increases in school, there has always been a necessary need to protecting students from direct sun, and thus; shading played an important role and became a necessity. One of the lighting-redirecting devices, that is well-known for regulating daylighting distribution, blocking direct sunlight and commonly used in educational facilities, is the light shelf.

Light shelf is a sun breaker that regulates daylight by cutting direct sunlight. There has been a body of literature reviewing light shelves from functional and performance points of view, as well as studies sought finding the optimal dimensions of light shelves, to name a few (Rogers and Goldman 2006; De Carli and De Giuli 2009; Littlefair 1995; Moazzeni and Ghiabaklou 2016; Raphael 2011; Hu, Du, and Place 2011; Abdulmohsen, Boyer, and Degelman 1994; Soler and Oteiza 1996; Ochoa and Capeluto 2006; Kurtay and Esen 2017; Freewan 2010; Moore 1985; Kostantoglou and Tsangrassoulis 2012; Lee, Kim, and Seo 2018; Brotas and Rusovan 2013; Lee et al. 2017; Almssad and Almusaed 2014; Freewan, Shao, and Riffat 2008; Ishac and Nadim 2021). Rogers and Goldman (2006) simulated light shelf, overhang, and internal shades in classrooms. The recommended constraints of the light shelves based on past literature are within 20-120 cm for an external shelf and 20-80 cm for an internal shelf. The study conducted by De Carli and De Giuli (2009) suggested using longer light shelves (135 x 80cm) in lower latitude countries and shorter light shelves (80 x 40cm) in

PARAMETRIC SIMULATION AND SENSITIVITY OF LIGHT SHELF ON DAYLIGHTING AND SHADING: LIGHT SHELF PERFORMANCE MAP

higher latitude countries in the northern hemisphere. Ishac and Nadim (2021) reviewed the previously mentioned literature for the daylighting and shading performance of the light shelf tested with respect to latitudes. The study, furthermore, simulated and optimized light shelf in an architectural studio at the German University in Cairo and concluded a near-optimal light shelf in the south façade to have external and internal dimensions of 120 x 80 cm, respectively.

However, to the best knowledge of the author, only one study attempted to simulate the effect of light shelves in different latitudes which is the study by Kurtay and Esen (2017), and few studies only provided rules of thumb' recommendations to the various shading systems to be used for different climates, such as; IEA (2000); Hausladen, Liedl and Saldanha (2011). To Kurtay and Esen (2017) used DSI to simulate light shelves and created design curves with 97% accuracy to determine the dimensions, position and height of suitable light shelves in different latitudes in a varied office room. However, the previous study was restricted to the International Commission on Illumination (CIE) overcast sky conditions, and not clear sky which might be dominant most of the year in other latitudes, e.g., Cairo (Robaa 2006). The same study incorporates DF daylight factor, which also does not consider local climate, orientations, and occupancy, and thus; not representing local climatic conditions. In light of this, this shows a clear gap in a research that attempts to find an accurate approximation to the dynamic and real daylighting in each city.

In light of the above, this shows a clear gap in a research that attempts to find an accurate approximation to the dynamic and real daylighting in each city.

4. Methodology

The contribution of this work is to devise a 'light shelf performance map' based on the dynamic component of daylighting and accounting for the real climatic conditions in three northern latitudes which considered as representatives (*TABLE 1*), with their solar path shown in Figure 2. This could predict and learn about the annual daylighting and shading performance of light shelves over different locations, and thus approximate the most suitable light shelf for each latitude to maximize its performance. The paper uses a hypothetical typical classroom with dimensions of 9 x 7.20 x 3 meters and with a south window of various size (Figure 1). The classroom is divided into three zones to monitor the effect of the devices in

the front, middle, back of the room. South was selected as the simulated orientation, as it receives most of the overhead sunlight and has more potential for harvesting daylighting, while East or West are the least favored orientations for classrooms.

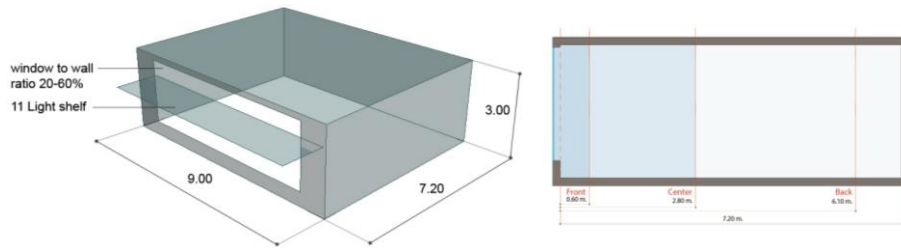

Figure 1. Hypothetical typical classroom and zones

TABLE 1. Proposed geographical latitudes

Location	Hemisphere	Actual Latitude (°)	Representative Latitude (°)	Daylight length (hours)	
				June 21 st	December 21 st
Stockholm, STO	Northern	N 59° 39'	N 60°	18:37	6:04
Cairo, CAI	Northern	N 30°	N 30°	14:04	10:12
Nairobi, NAI	Southern	S 1.29°	0°	12	12

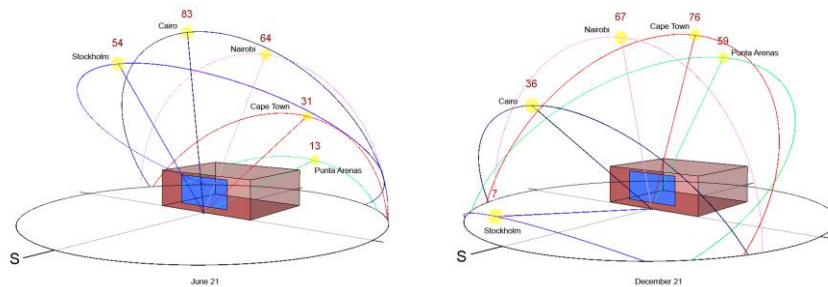

Figure 2. Solar path for the studied locations in June and December 21st days.

A set of 11 light shelf types (Figure 3) which vary increasingly on steps of 20 cm to cover a large variation of shelves. Radiance is used to simulate annual daylighting (Ward and Shakespeare 1998, Mardaljevic 1995) using DAV and UDI which consider dynamic daylight as they use local weather files of each city. Then, simulated illuminance is processed using visual basic scripts, and then analyzed in MATLAB to proceed with calculations and plot line and radar diagrams. Parametric variables are listed *TABLE 2*.

PARAMETRIC SIMULATION AND SENSITIVITY OF LIGHT SHELF ON DAYLIGHTING AND SHADING: LIGHT SHELF PERFORMANCE MAP

Radar diagrams can provide insights into the strength and weakness of each light shelf and magnitude of improvement, with respect to base case, in four daylighting objectives (described above), which are: shading, increasing daylight levels in the middle (2.80 m) and at the back (6.10 m) of the room, and lastly average uniformity which is calculated as ratio of the minimum to average illuminance, on average of the two months of Jan (winter) and June (summer). The performance curves are devised by a relation to fit the known performance data to quadratic-degree regression curves, which minimize the error in the simulated data and could lead to form these curves.

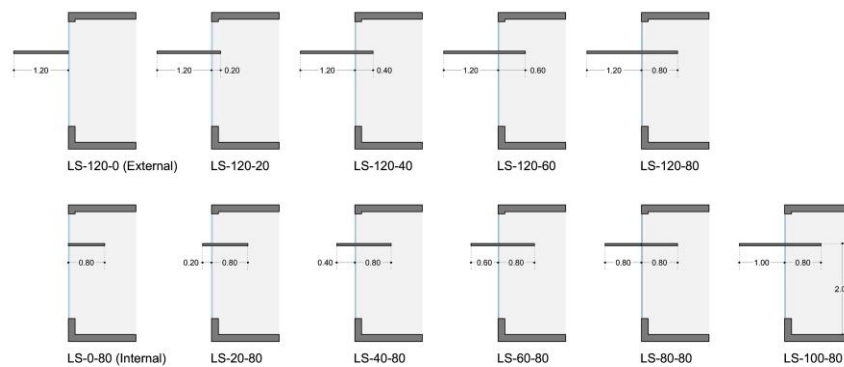

Figure 3. Light shelf models

TABLE 2. Parametric variables

Variable	Value
Room Dimensions	9.00 x 7.20 x 3.00 m
Window to Wall Ratio	Variable, 20 / 30 / 40 / 50 / 60%
Window orientation	Fixed, South
Light shelf Height	Fixed, 2 meters
Occupancy Schedule	5 days / week - 8 hours (From 8 AM - 4 PM)
Horizontal working plane	75 cm above finish floor level
Grid sensors	50 cm spacing between sensors
Weather File	Stockholm / Cairo / Nairobi
Sky type	Weather data dependent
Minimum horizontal illuminance	500 lux
Material reflectance	Floor 20%, ceiling 80%, wall 70%, light shelf 90%
Glass light transmittance	VLT 60%

5. Results

5.1. IMPACT OF WINDOW SIZE ON DAYLIGHTING

As the window increases, daylighting increases significantly through the width of the room, more than across the depth, which increases but slightly (

Figure 4). The relative difference in the magnitude of illuminance across the depth of the room, received by windows from 20 to 60%, is a nearly a fixed offset in the five openings. In conclusion, large windows do not increase daylighting illuminance through the depth of the room. In the following investigations, window size of 60% WWR will be, further, analyzed.

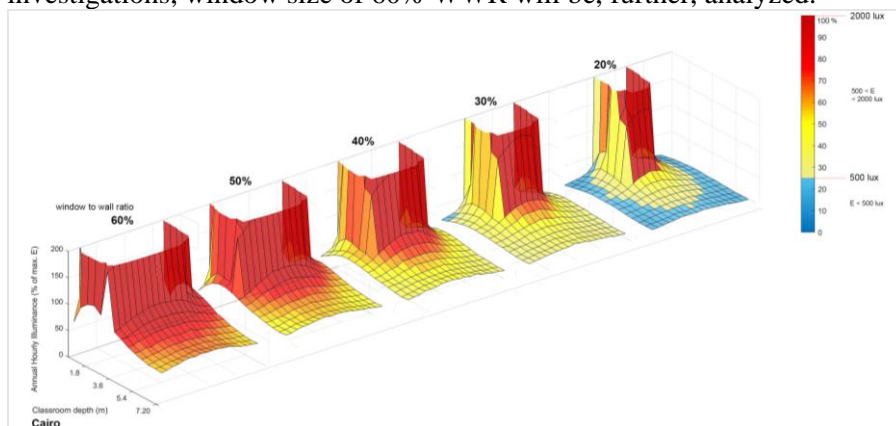

Figure 4. Annual hourly illuminance 3D diagrams for variation of window size in Cairo

5.2. POINT-IN-TIME AND SEASONAL ILLUMINANCE IN LATITUDES

In summer, daylighting levels decrease significantly as we go down from the far north (26000 lx) to the equator (6000 lx). Levels are the highest inside the room in Stockholm due to the relative lower sun position with respect to its location in other latitudes which are higher (Figure 2). In the cold season, direct sunlight around 6000 lx penetrates through the whole depth of the classroom in Stockholm due to the lowest solar elevation (altitude 7°). This reflects the need for a shading device which can block low direct sunlight. In Nairobi, extreme high levels of daylight enter nearby the window until 1 meter away from the window, and then it falls very sharply as sunlight comes from near the zenith. In Cairo, daylight falls gradually due to the lower sunlight angle than in Nairobi, to reach around 6000 lx at about 4 meters away from window.

PARAMETRIC SIMULATION AND SENSITIVITY OF LIGHT SHELF ON DAYLIGHTING AND SHADING: LIGHT SHELF PERFORMANCE MAP

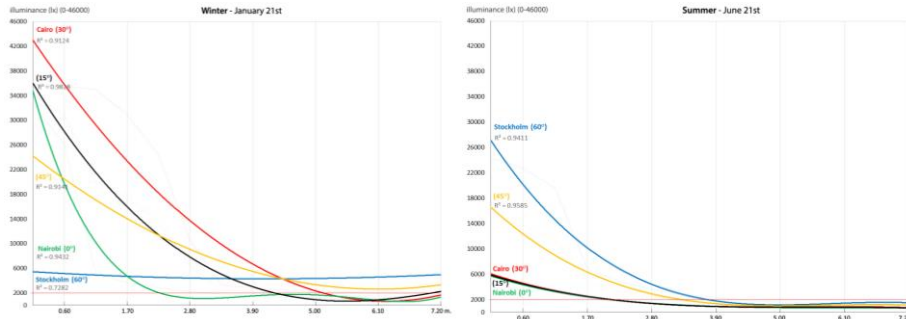

Figure 5. Illuminance best fit curves of base case in winter and summer

5.3. ANNUAL DAYLIGHT PERFORMANCE OF LIGHT SHELF MODELS

The annual performance of light shelves is firstly studied using DAV metric. Figure 6 shades the light on the improvement of daylighting by the different light shelves in the studied latitudes, rather than on shading. The LS-80-120 had a stronger impact on improving daylighting in 30° (13%) and 60° (12%). In Nairobi 0°, daylighting improved by the internal shelf, more than by the external shelf.

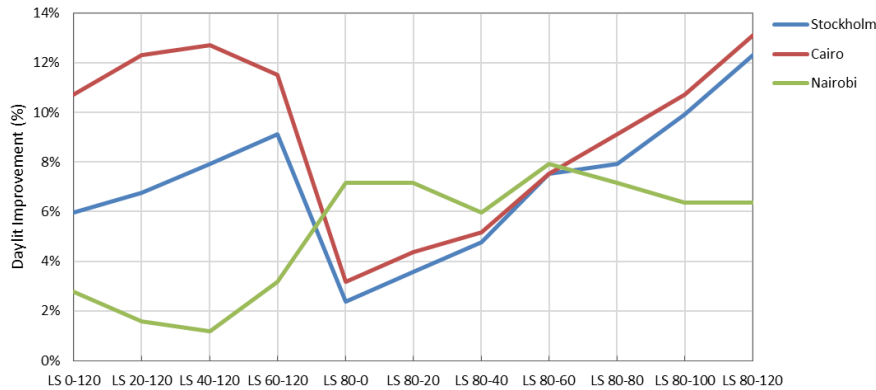

Figure 6. Daylit improvement (%) by light shelf models in studied latitudes

5.4. PERFORMANCE SENSITIVITY OF LIGHT SHELF MODELS

Radar diagrams plot the UDI to highlight the most effective device in each objective in various latitudes (Figure 7-12). The range of shading effectivity of all light shelf models is smaller as we go from equator to far north. This reveals how a wide range of horizontal shading devices can easily variate in shading direct sunlight in cities near the equator. As we go north, all horizontal devices alike, shade direct sunlight similarly without large differences in shading capacity (Figure 11). In shading efficiency, the LS-

80-120 outperforms all other shelves, but with relative reductions from one latitude to another. In Latitude 0° it reduces the overlit the most (-54% of the time per year), -27% in latitude 30°, and -18% in latitude 60°. In latitude 0° where the sun has high elevation angle, both an external and internal shelf are necessary to block direct light. The longest external light shelf (LS-0-120) shades better in latitude 60° than in low latitudes.

Regarding daylight in the middle of the room, the shelves (internal LS-80-0) and (LS-80-120) respectively play a small role in improving daylight (increase by 9%) in latitudes 0° and 60°. Almost none of the shelves increased daylight in latitude 30°. At the back of the room, LS-60-120 increased annual daylight by 5% in latitude 30°. Most of the shelves (8 out of 11) in that latitude improved daylight at the back very slightly. In latitudes 60° and 0°, nearly all shelves diminished daylight at the back of the room.

An external light shelf improved uniformity distribution across the room with relative impacts in each location. The longest light shelves (LS-80-120) led to improving the average annual uniformity in all latitudes, significantly in the equator by 0.30, by 0.20 in latitude 30°, and very slightly in north 60°.

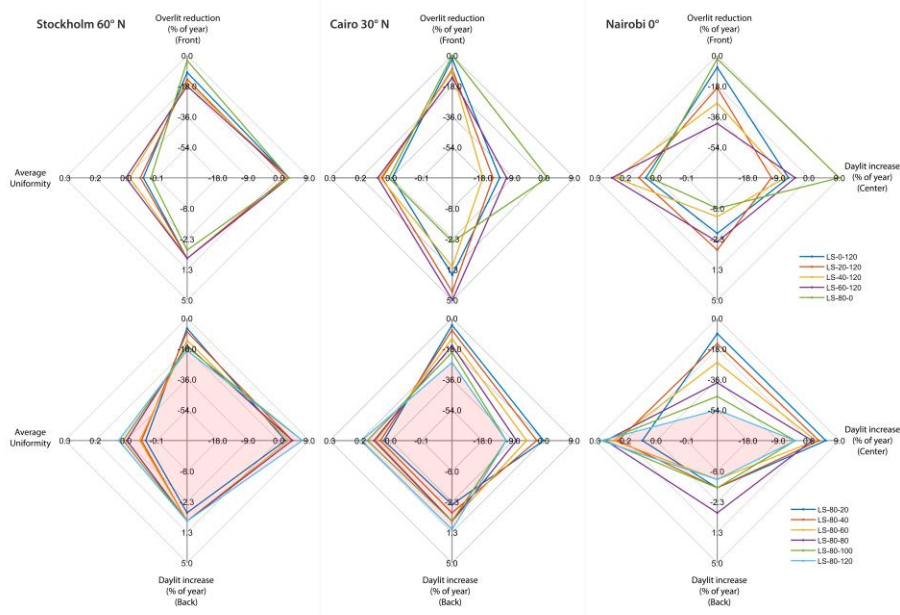

Figure 7. Effective light shelves in shading performance

PARAMETRIC SIMULATION AND SENSITIVITY OF LIGHT SHELF ON DAYLIGHTING AND SHADING: LIGHT SHELF PERFORMANCE MAP

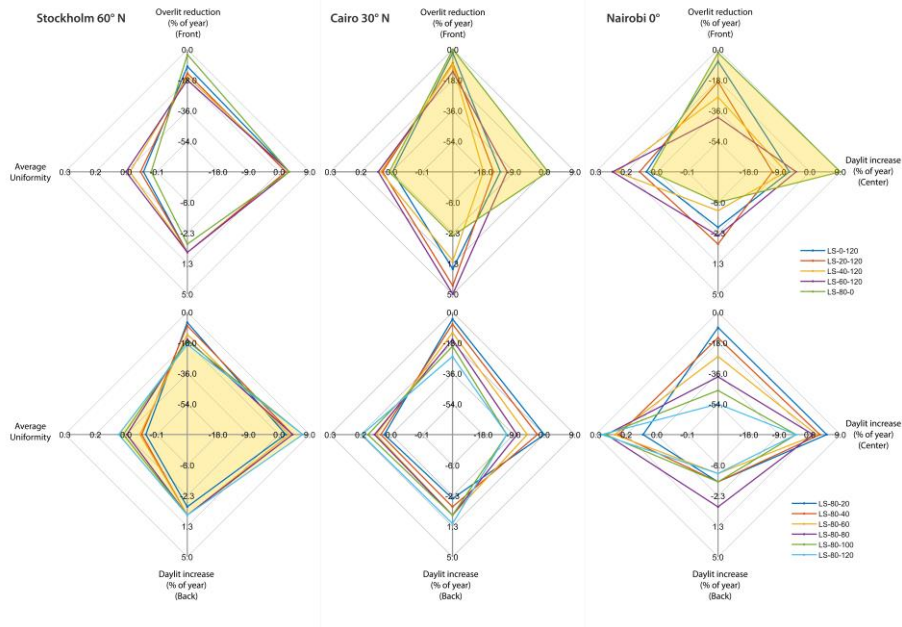

Figure 8. Effective light shelves for increasing annual daylight in the middle of the room

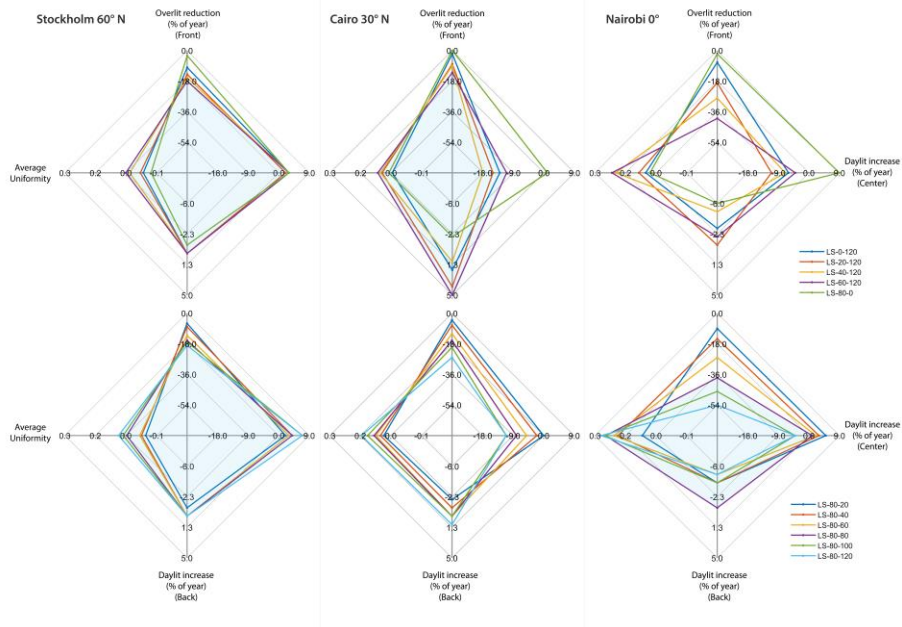

Figure 9. Effective light shelves for increasing annual daylight at the back of the room

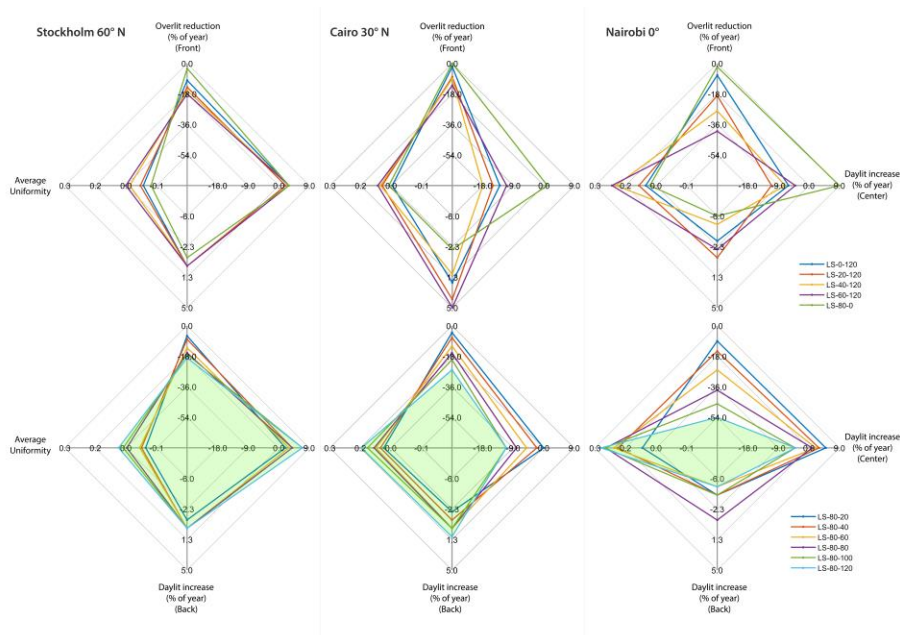

Figure 10. Effective light shelves for improving annual average uniformity

5.5. PERFORMANCE CURVES OF LIGHT SHELF MODELS

Performance curves are lines which best fit the annual UDI performance of the studied latitudes by regression. The second step is interpolation to use these curves to estimate the daylighting and shading performance of base case located in other unexamined latitudes, with/out the light shelves impact. This is also to differentiate which of the light shelf models would best suit to this specific latitude.

Figure 11 shows performance curves of light shelf models. Cities near the equator 0° and latitudes 30° experience large periods of direct sunlight, compared to a smaller period in the north. The middle part in latitude 0° receives more useful daylight (80%) than direct sunlight (20%), compared to shorter period of useful daylight (30%) and longer period of direct sunlight (45%) in latitude 60°. Inadequate levels of daylight at the back of the room rise as we go north to reach 40% of the year, compared to short periods of time (10%) near the equator.

Architects can utilize these maps as a preliminary design tool to interpolate a latitude of interest and predict daylighting performance in that location, without simulations. These curves are an approximation for daylighting performance which take into account its dynamic variability and availability

PARAMETRIC SIMULATION AND SENSITIVITY OF LIGHT SHELF ON DAYLIGHTING AND SHADING: LIGHT SHELF PERFORMANCE MAP

in various latitudes worldwide. A demonstration example is depicted in same Figure 11 to learn about daylighting and test the performance of light shelves in Munich (48°N) and Ethiopia (9°N). Munich was found to receive around 80% of time direct sunlight in the front part of the room and 20% useful daylight, While Ethiopia receives around 100% of the year direct sunlight. LS-80-120 would increase the useful daylight at the front significantly in Ethiopia (45%) than in Munich (20%). Furthermore, an internal shelf alone (LS-80-0) would increase useful daylight to 5% in the middle of the room.

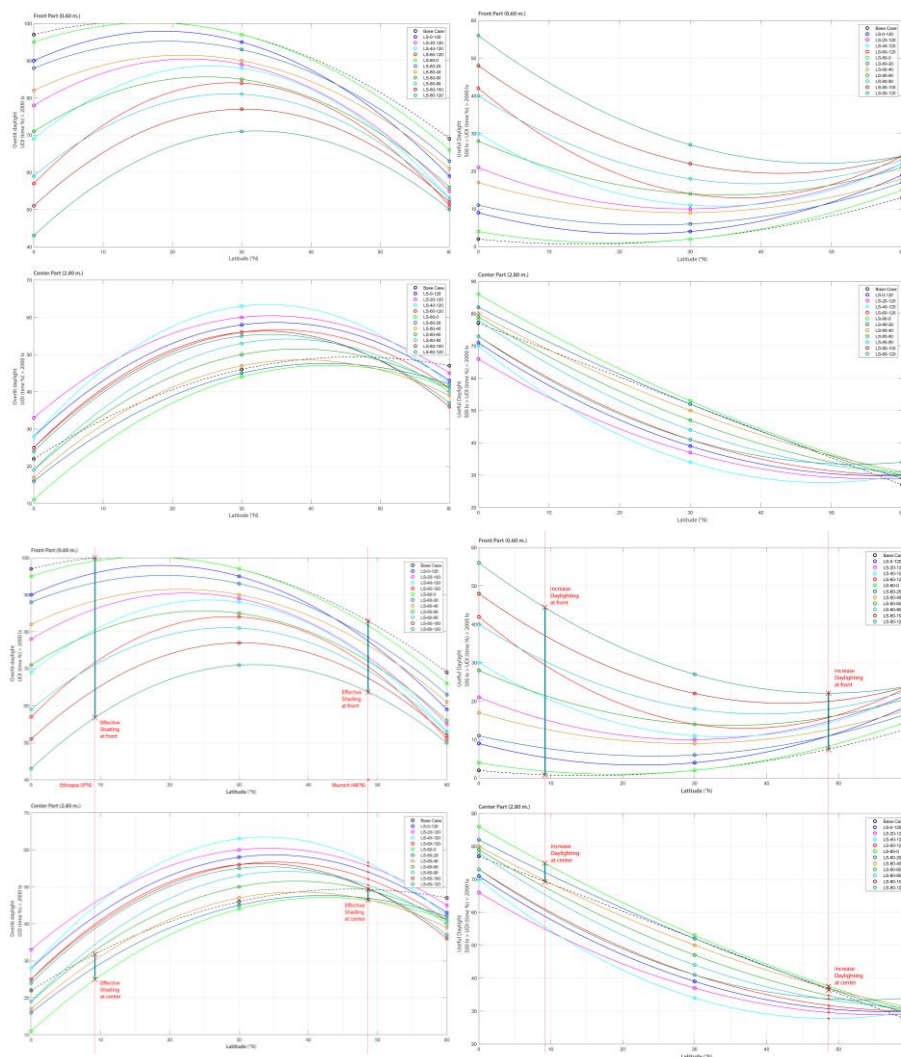

Figure 11. Performance curves of light shelves and interpolating unexamined latitude

5. Discussion

This study confirmed that longer light shelves (LS-80-120 and its variations) are the most effective shading devices in lower latitudes than to higher latitudes. Shorter combination (LS-80-0) is advantageous to improve daylighting slightly in the middle of the room in Nairobi, but with compromise on reducing shading. In latitude 30°, most of the shelves improved very slightly annual daylight at the back of the room. In opposite in latitudes 0° and 60°, nearly all shelves diminished daylight. An external light shelf proved to improve the uniformity distribution across the room.

6. Conclusion

Natural light is vital for students' performance and health. This paper aims to explore the effect of light shelf on daylighting and shading performance in various studied locations, specified by latitudes. Given the simulated illuminance in these known locations, best fit curves are drawn to develop a map, so called 'performance curves' map. This map is used to predict the near-optimal light shelf that would best suit in any unexamined locations. Radar plots envisage the potentials and sensitivities of each light shelf in achieving daylighting objectives, and hence can differentiate the suitable model.

The findings of this paper can be generalized to any other location since the classroom used was a hypothetical with typical dimensions. Architects can utilize these maps as a preliminary design tool to approximate and predict performance without simulation. It is important to note that the performance curves are an approximation to the real and dynamic daylighting conditions in many locations worldwide, however, future studies are required to validate the accuracy of the curves, statistically correlate them to real measurement, and would need to include other factors that affect daylighting availability; such as: sky cloudiness. Also, future work can be extended to experimenting other variables; such as: orientation, room height, and reflectance.

PARAMETRIC SIMULATION AND SENSITIVITY OF LIGHT SHELF ON DAYLIGHTING AND SHADING: LIGHT SHELF PERFORMANCE MAP

References

- Abdulmohsen, A., L. Boyer, and L. Degelman, 1994. "Evaluation of Lightshelf Daylighting Systems for Office Buildings in Hot Climates." Symposium on Improving Building Systems in Hot and Humid Climates, Texas.
- Almssad, A., and A. Almusaed, 2014. "Efficient Daylighting Approach by Means of Light-Shelve Device Adequate for Habitat Program in Aarhus City." *International Journal of Smart Grid and Clean Energy* 3 (4): 441–453.
- Arnesen, H., Kolas, T. and Matusiak, B., 2011. A guide to daylighting and solar shading systems at high latitude. ZEB Project report 3.
- Baker, L., 2012. A History of School Design and its Indoor Environmental Standards, 1900 to Today. National Institute of Building Sciences. National Clearinghouse for Educational Facilities - Descriptive Report.
- Brotas, L., and D. Rusovan, 2013. "Parametric Daylight Envelope. Sustainable Architecture for a Renewable Future," Munich.
- Caldas, L., Norford, L., 2001. "Architectural constraints in a generative design system: interpreting energy consumption levels." Building Simulation IBPSA Conference, Brazil.
- Cellai, G., Carletti, C., Sciurpi, F., and Secchi, S., 2014. "Transparent Building Envelope: Windows and Shading Devices Typologies for Energy Efficiency Refurbishments." Building Refurbishment for Energy Performance, Green Energy and Technology.
- De Carli, M., and De Giuli, V., 2009. "Optimization of Daylight in Buildings to Save Energy and to Improve Visual Comfort: Analysis in Different Latitudes." Building Simulation, IBPSA Conference, Scotland.
- Danilenko, K.V. et al., 2000. Phase advance after one or three simulated dawns in humans. *Chronobiology International: Journal of Biological & Medical Rhythm Research*.
- Freewan, A. A., L. Shao, and S. Riffat, 2008. "Optimizing Performance of the Lightshelf by Modifying Ceiling Geometry in Highly Luminous Climates." *Solar Energy* 82: 343–353.
- Freewan, A. A., 2010. "Maximizing the Light Shelf Performance by Interaction Between Light Shelf Geometries and a Curved Ceiling." *Energy Convers. Manag* 51: 1600–1604.
- Hausladen, G., Liedl, P. and Saldanha, M., 2011. Building to suit the climate A Handbook. Birkhäuser Basel publisher.
- Heschong Mahone Group, 1999. "Daylighting in Schools, An Investigation into the Relationship Between Daylighting and Human Performance." A Report to Pacific Gas and Electric.
- Hu, J., J. Du, and W. Place, 2011. "The Assessment of Advanced Daylighting Systems in Multi-Story Office Buildings Using a Dynamic Method." *Low-Energy Architecture, Sweden*.
- IESNA. 2000. "Illuminating Engineering Society of North America." *Lighting Handbook: Reference and Application*.
- Ibrahim, N., Hayman, S., and Hyde, R., 2009. The influence of latitude variations on daylighting rule of thumb effectiveness. 43rd Annual conference of Architectural science association, University of Tasmania.
- International Energy Agency IEA. 2000. Daylight in Buildings. A source book on daylighting systems and components. Solar Heating and Cooling Programme, Energy Conservation in Buildings & Community Systems. Lawrence Berkeley National Laboratory, U.S. Department of Energy.
- Ishac, M. & Nadim, W., 2021. Standardization of optimization methodology of daylighting and shading strategy: a case study of an architectural design studio – the German University in Cairo, Egypt, *Journal of Building Performance Simulation*, 14:1, 52-77
- Kostantoglou, M., and Tsangrassoulis, A., 2012. Performance Evaluation of an Automatically Controlled Light-Shelf. 5th Balkan light Conference, Serbia.

M. ISHAC

- Kurtay, C. and Esen, O., 2017. A new method for light shelf design according to latitudes: CUN-OKAY light shelf curves. *Journal of Building Engineering*.
- Lee, H., S. Kim, and J. Seo. 2018. Evaluation of a Light Shelf Based on Energy Consumption for Lighting and air Conditioning.” *Indoor and Built Environment* 27 (10): 1405–1414.
- Lee, H., G. Jeon, J. Seo, and Y. Kim. 2017. Daylighting Performance Improvement of a Light-Shelf Using Diffused Reflection. *Indoor and Built Environment* 26 (5): 717–726.
- Littlefair, P. J., 1995. Computer Assessment of the Daylighting Performance of Light Shelves. *Lighting Research and Technology* 27 (2): 79–91.
- Mardaljevic, J., 2000. The Simulation of Annual Daylighting Profiles for Internal Illuminance. *Lighting Research and Technology* 32 (3): 111–118. 1.
- Mardaljevic, J., 1995. Validation of a lighting simulation program under real sky conditions, *Lighting Research & Technology*, 27(4), pp.181-1.
- Moazzeni, M. H., and Z. Ghiabaklou. 2016. Investigating the Influence of Light Shelf Geometry Parameters on Daylight Performance and Visual Comfort, a Case Study of Educational Space in Tehran, Iran. *Buildings* 6 (3): 26.
- Moore, F., 1985. *Concepts and Practice of Architectural Daylighting*. New York. Van Nostrand Reinhold.
- Ochoa, C. E., and I. G. Capeluto. 2006. Evaluating Visual Comfort and Performance of Three Natural Lighting Systems for Deep Office Buildings in Highly Luminous Climates. *Building and Environment* 41: 1128–1135.
- Raphael, B., 2011. Active Control of Daylighting Features in Buildings. *Computer-Aided Civil and Infrastructure Engineering* 26: 393–405.
- Reinhart, C. F., and A. Fitz, 2006. Findings from a Survey on the Current use of Daylight Simulations in Building Design. *Energy and Buildings* 38: 824–835.
- Robaa, S. M., 2006. A Study of Solar Radiation Climate at Cairo Urban Area, Egypt and its Environs. *International Journal of Climatology* 26: 1913–1928.
- Rogers, Z. and Goldman, D., 2006. Daylighting Metric Development Using Daylight Autonomy Calculations in the Sensor Placement Optimization Tool Development Report and Case Studies.
- Ruck, N. et al., 2000. Daylighting in buildings. IEA-Task-21. The International Energy Agency.
- Soler, A., and P. Oteiza., 1996. Dependence on Solar Elevation of the Performance of a Light Shelf as a Potential Daylighting Device. *Renewable Energy* 8: 198–201.
- Ward, G. and Shakespeare, R., 1998. *Rendering with radiance. The art and science of lighting visualization*. San Francisco, CA. Morgan Kaufmann.

ENERGY AND DAYLIGHT PERFORMANCE OPTIMIZATION OF BUTTERFLY INSPIRED INTELLIGENT ADAPTIVE FACADE

ALI NAJAFI, PEIMAN PILECHIHA

Department of Architecture, Bu Ali Sina University, Hamedan, Iran.

Email address: a.najafi.design@gmail.com

Department of Architecture, Tarbiat Modares University

Department of Architecture, Kowsar Institute of Higher Education, Qazvin, Iran.

Email address: p.pilechiha@modares.ac.ir

Abstract. The Adaptive Solar Façade (ASF) as an integrated dynamic and flexible building facade could be a hopeful design tool to provide residents comfort and energy efficiency by applying relevant integrated parametric design. Based on that, in this study, we investigated a designing process and optimization of ASF concentrating on providing the visual comfort and energy efficiency. We start with an extended summary of previous studies which has been done for developing a dynamic system correspond to origami and butterfly wings. Afterwards, we design 10 movement patterns for façade at the next stage, we simulate the Illuminance uniformity distribution and amount of energy consumption in the interior area. It should be noted that this simulation is done hourly. Therefore, 52 base models were investigated in Hamedan without using intelligent façade. It should be considered that these models are offices and they are investigated in the cold tundra in four days of the year between 6 A.M. to 6 P.M. Afterwards, 520 façade affected proposed models simulated for comparing to the base model. We have done the latter simulation using Colibri plugin while it optimized linearly. All of the datasets have been processed in an algorithm circulation for analyzing the simulations results.

Keywords: *Adaptive Solar Façade, Light Efficiency, Parametric Design, Algorithmic Simulation, Visual Comfort, Energy Efficiency*

ملخص. يمكن أن تكون الواجهة الشمسية التكيفية (ASF) كواجهة بناء ديناميكية ومرنة متكاملة أداة تصميم مأمولة لتوفير الراحة للسكان وكفاءة الطاقة من خلال تطبيق تصميم حدودي متكامل ذي صلة. بناءً على ذلك، في هذه الدراسة، قمنا بالتحقيق في عملية تصميم وتحسين ASF مع التركيز على توفير الراحة البصرية وكفاءة الطاقة. نبدأ بملخص موسع

للدراسات السابقة التي تم إجراؤها لتطوير نظام ديناميكي يتوافق مع الأوربيغامي وأجنحة الفراشة. بعد ذلك، نقوم بتصميم 10 أنماط حركة للواجهة في المرحلة التالية، نقوم بمحاكاة توزيع انتظام الإضاءة ومقدار استهلاك الطاقة في المنطقة الداخلية. وتجدر الإشارة إلى أن هذه المحاكاة تتم كل ساعة. لذلك، تم فحص 52 نموذجًا أساسيًا في مدينة همدان دون استخدام الواجهة الذكية. يجب اعتبار أن هذه النماذج عبارة عن مكاتب ويتم فحصها في التندرا الباردة في أربعة أيام من العام بين الساعة 6 صباحًا حتى 6 مساءً بعد ذلك، تأثرت 520 واجهة من النماذج المقترحة التي تمت محاكاتها للمقارنة بالنموذج الأساسي. لقد أجرينا المحاكاة الأخيرة باستخدام البرنامج المساعد Colibri أثناء تحسينه خطيًا. تمت معالجة جميع مجموعات البيانات في تداول خوارزمية لتحليل نتائج المحاكاة.

الكلمات المفتاحية: واجهة شمسية تكيفية، كفاءة الضوء، تصميم حدودي، محاكاة خوارزمية، راحة بصرية، كفاءة في استخدام الطاقة.

1. Introduction

This article focuses on smart facades as a climate-compatible design technique which response to both direct environmental inputs and user needs. Multiple studies have shown that energy consumption in construction sector includes 34% of total energy consumption all over the world which is even higher than the share of energy consumption per capita in the transport sector and factories (Soflaei et al. 2017). On the other hand, Maldigom institute of physics introduces the facades of buildings as responsible for wasting 40% of the energy of buildings, which is caused by overheating in summer and heat loss in winter, which is inevitable to provide comfort to internal space residents there is no choice except to use air conditioning systems (Barozzi et al. 2016).

Today, the idea of adaptive smart facades (ASF) has been proposed by many researchers and designers (Loonen et al. 2013; Bueno et al. 2018; Attia et al. 2015).

Previous studies have shown that design methods with light and energy-efficiency approaches are one of the most important methods to increase the residents comfort in the interior (Panopoulos and Papadopoulos 2017; Rodriguez et al. 2014). However, daylight can cause undesirable reflection or concentration of radiation in certain parts of the space, which in itself reduces visual comfort and energy-efficiency (Suk, Schiler, and Kensek 2016). Accordingly, there is need to exposure a responsive system for adaptive shading system with adaptability to different climate conditions to supply visual comfort and reduce energy consumption (Nagy et al. 2016).

Many studies have been done in the field of visual comfort and energy-efficiency (Barozzi et al. 2016; Attia et al. 2015; Bueno et al. 2018; Freewan and Al Dalala 2020; Nagy et al. 2016). But the challenges of providing visual comfort and increasing energy efficiency in a building with a glass facade (office) remain (Eltaweel and SU 2017; Hafiz 2015). In this regard, this article specifically examines a smart facade that is inspired by the

ENERGY AND DAYLIGHT PERFORMANCE OPTIMIZATION OF BUTTERFLY INSPIRED INTELLIGENT ADAPTIVE FACADE

morphology of the butterfly wing and structured based on origami, to provide visual comfort (ensure uniformity of light distribution) to residents and reduce energy consumption in an administrative department in the cold and dry climate of Iran, which has been selected as a case study of this climate of Hamadan.

2. Research Background

Adaptive facades are not a new concept for sustainable building facades but have gone through several stages since the beginning of the twentieth century (Hopkinson 1972). Therefore, significant efforts have been made to develop smart buildings in the field of energy with a focus on advanced systems (Attia et al. 2018; Park et al. 2003; Sadek and Mahrous 2018). The energy-saving potential of these systems, such as electrochromic windows, has led to many applications (Attia et al. 2015), as they can adapt themselves to changing climatic conditions.

The term adaptation here refers to reaction potential or take advantage of external climatic conditions for the comfort of residents, welfare needs and reduced energy consumption (Loonen et al. 2013). In this regard, the uniformity of light distribution is considered as one of the main elements of quality of space, which can play an important role in maintaining the health, efficiency and comfort of residents (Bian, Leng, and Ma 2018; Hafiz 2015). As another solution, adaptive systems with integration in the facade of sustainable buildings can be an important factor in reducing the need for artificial light, cooling or heating in different seasons, which increases the level of energy-efficiency (Ruck, N; Aschehoug, Oe; Aydinli 2000).

3. Research methods

The type of progressive research is categorized as usage research based on the purpose. The progressive research method is a descriptive-analytical method and its information has been collected in a library method and using the sources and information available in books and articles.

The ultimate goal of this research is to offer an adaptive modular smart facade (ASF) that can adapt to climatic conditions according to the needs of users. To achieve this goal, the architectural idea for designing an initial research project of innovation and inspiration from the butterfly wing movement, as you can see in figure 2, (Shanks et al. 2015), whose simulation mechanism was based on origami concept used.

One way to achieve the various forms of exterior design that are classified by different factors is to determine the strengths and weaknesses

points of each layout. This method provides the possibility of different layouts of smart facade modules (Nagy et al. 2016).

This study, inspired by the morphology of butterfly wing by rules of parametric design of origami, led to the formation of a smart kinetic structure and a hypothesis based on existing studies in this field, which to quantify this hypothesis using parametric design tools, a designed model to climate simulate in different facade states was evaluated using Ladybug tools, to optimize all the existing states, linear optimization was used by colibri tool, finally, using the design tool, the results of the simulation were analyzed. In this research, the facilities and limitations of creating ASF using the algorithm in an applied case study in a singular office space facing south in the city of Hamadan-Iran with cold and dry climate have been investigated. The case study is classifiable into four consecutive phases as follows:

Modelling: in the first phase, inspired by the morphology of the butterfly wing, the dynamic behaviour of the smart facade was studied, then using the rules governing the origami algorithmic design, this model was designed as a parametric model in the Rhino/Grasshopper.

Simulation: in the second phase, the designed model using Ladybug and Honeybee plugins was placed in the climate conditions of Hamadan, the simulated models in this phase were evaluated in two basic states that were without smart facade application and in the research model state which were capable of change state for every 10 hours. The simulation results in this phase included EUI and sIUD study, which represent the hourly energy consumption and uniformity of indoor lighting distribution.

Optimization: in the third phase, linear algorithmic optimization was performed using colibri tools, object mapping (independent variables) was performed by this tool in parallel with the simulation steps following changes in input genomes (dependent variables). Downloadable file for data analysis in design explorer environment, .csv extension was received at the output of this composite. The performed optimization can be classified in the section of multi-objective linear optimizations.

Analysis of results: the fourth phase includes the analysis of the results of the optimization, which tried to eliminate the local optimum results by applying constraints and selecting the best facade state per hour.

3.1. MODELLING

The initial concept was created in such a way that according to many studies, the butterfly wing movement pattern can affect the amount of radiation absorption and in nature, the butterfly increases or decreases this amount of reception by changing its wing angle to receive sunlight.

ENERGY AND DAYLIGHT PERFORMANCE OPTIMIZATION OF BUTTERFLY INSPIRED INTELLIGENT ADAPTIVE FACADE

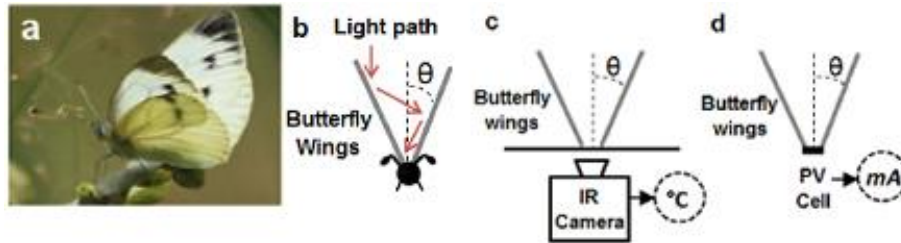

Figure 1. Innovation and inspiration from the butterfly wing movement (shanks et al .2015).

The mechanism of using the amount of radiation in the butterfly is in the situation that in the early morning to warm the muscles that move the wing, it changes the angle of the wing, in figure 1 you can see this mechanism (Shanks et al. 2015).

In the present study, by stylizing the butterfly wing and turning it into a repeatable module, this facade is placed in the facade of the building and tries to find the best angles to optimize light and energy, this module can change the mode parametrically in 10 modes, which the algorithm writing process of this facade is shown in Figure 2.

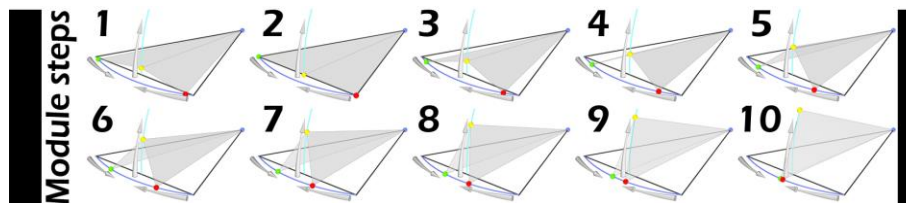

Figure 2. Butterfly module steps

3.2. SIMULATION

The purpose of this study is to investigate the effect of the designed facade on indoor lighting and amount of energy consumption. Ladybug and Honeybee support the ability to model daylight and thermodynamic model algorithmically during all simulation steps by importing the .epw weather file. Honeybee calculates the results of simulation using radiance, energy models using Energy Plus / Open Studio and heat flow through construction details using Berkeley Lab Therm/Window.

3.2.1. Simulation data collection

The first step in simulation is the definition of the zone or the simulation room that all light and energy analysis is performed in this room. Considering that the orientation of the building is not one of the variables of this research, therefore, in all simulation cases, the north-south orientation is considered. The south wall, which is the main wall, was considered to be

95% WWR and this percentage of the opening is also considered to prevent the coefficients of the interfering variable during the simulate process (Pesenti et al. 2015).

The reflection coefficient for the walls in the material radiance was considered to be 0/5, 0/5, 0/5, respectively, for the floor, coefficients of 0/2, 0/2, 0/2, considered and for the ceiling, coefficients of 0/8, 0/8, 0/8, were considered, which are considered the same in all simulation states (Compagnon 1997).

To analyze the energy to eliminate the effect of heat transfer coefficient and heat resistance, the walls of the base model and the adiabatic research model were defined.

The mechanical equipment system (HVAC) in this analysis is an ideal system based on the ASHRAE standard, which can be defined in Ladybug software default (Lynch et al. 2013). In this study the value of 0/0001 was considered for unwanted ventilation (USGBC 2016).

In this study, analysis based on a grid base sensors. For light analysis, 460 sensors were installed at a distance of 80cm from the floor, which each of sensors located at a distance of 30cm from the next sensor. The type of modelled space with office use is considered and this use is effective on the table of presence and use of space by residents (Lynch et al. 2013).

All analysis performed in this study performed on an hourly basis and due to the extent of the analyses. From all days of the year, the days of midsummer, midwinter, spring equinox and autumn equinox were chosen. Analyzes were repeated every four days from 6 A.M. to 6 P.M. and a total of 52 hours were analyzed.

3.2.2. Measurement indicators

All tables of results obtained from the analysis were classified and analyzed based on these indicators. It is worth to mention that to facilitate the identification of these indicators, they were divided into two series: light evaluation indicators and energy evaluation indicators.

To measure illuminance in this study, the illuminance uniformity distribution which is presented in European standard EN 12464-1 was used in sections 4, 3, 3, this standard is related to light evaluation indicators in office space, which was selected as user-selected case sample (Technical Committee CEN/TC 169 “Light and Lighting” 2002).

This standard is used to evaluate the amount of illuminance of a bench surface, in this way, the amount of light received, which is considered illuminance here, in first evaluated by sensors at the bench surface, then the average of all light receipts is calculated accordance of lux, in the next step, if the point with the lowest light reception received at least 40% of the average total light reception, is was able to pass this standard. The formula 1

ENERGY AND DAYLIGHT PERFORMANCE OPTIMIZATION OF BUTTERFLY INSPIRED INTELLIGENT ADAPTIVE FACADE

used for calculating the uniform illuminance distribution indicator (Wagiman and Abdullah 2018).

$$U_o = E_{min}/E_{avg} \quad (1)$$

E_{min} : the minimum amount of light reception, E_{avg} : the average of light received from sensors on the bench surface in one hour, U_o : light uniformity distribution index.

The main question in the research process in connection with the measurement of this indicator was how to evaluate this indicator on a larger scale than the surface of a bench?

The answer was obtained in the form of algorithmic coding in which the daylight uniformity distribution index was calculated spatially. In simpler term, if we measure the total space of a room, we get a large number of responses to the amount of light received, but how can we measure this indicator for the entire room. The solution was that the average light reception was obtained in all points with sensors in the room and then each point was compared with the average, alone, and the points were able to pass the standard were separated, by calculating the percentage of the sum of these points to the measured points, we obtain a number as a percentage, which of course, the higher this percentage indicates the better state of light distribution. This indicator was used as the “Spatial Illuminance Uniformity Distribution” and is indicated by sIUD.

$$E_{avg} = (\sum E_1 + \dots + E_n) / n \quad (2)$$

$$n_{Epass} = E_n / E_{avg} \geq 0.5 \quad (3)$$

$$sIUD = n_{Epass} / n \quad (4)$$

Which E_{avg} is average illuminance in all illuminance sensitive areas, n is the total number of illuminance sensitive points and n_{Epass} is the total number of points that received more than 50% of the average illuminance.

The EUI index was used to measure energy consumption, this indicator evaluates the amount of energy consumption based on the unit kWh/m².

$$EUI = (EUI_{cool} + EUI_{heating}) / A \quad (5)$$

Which EUI_{cool} is the amount of energy consumption to cool the whole space, EUI_{heat} is the amount of energy consumption to heat the whole space and A is the area of the analyzed space.

3.3. OPTIMIZATION

In the third phase, the optimization of the written algorithm in the first and second phases was performed by a Colibri tool from linearly TT-toolbox

tool kit, which is coded based on an artificial intelligence algorithm. The optimization was repeated once for the baseline model and once for comparison with the baseline model for the research model. In the basic model, two genomes were defined, the first genome of the month and the second genome of the time, the first genome was a factor of the change of the analysis days, which simulated the midsummer and midwinter and the spring and autumn equinoxes in the algorithm and the second genome was a time change agent on each of these days, from 6 A.M. to 6 P.M., in the research model, in addition to the first two genomes, a third variable was added that changed the facade movement states, these changes included 10 modes that were mentioned in the modelling section. The optimized results included 52 sIUD analysis modes, 52 EUI analysis modes for the baseline model and 520 sIUD analysis modes, 520 EUI analysis modes for a research model, which were transferred to Design explorer environment as a .csv file for data analysis.

3.4. ANALYSIS OF RESULTS

In the fourth phase, the recorded results by the Colibri tool were received in the form of a file that contains image analysis and a file with .csv extension and transferred to Design Explorer. Design Explorer is online numerical analyzing data program that designed to review the results of multi-objective researches (T. Tomasetti 2017).

All 520 analyzed states of illuminance and 520 analyzed states of energy, is drawn in Figure 3, input genomes are written in black at the top of the diagram and research objects are shown in blue, from left to right, the first diagram is displayed the month of analysis, which has a value equal to an integer between 1 and 4 to, which with a coefficient of 3 indicates the desired month in the Gregorian date, in the second column, you see the hours of research per day, which are the correct values between 6 A.M. and 6 P.M. and the third column shows facade states that have integer values between 0 and 9.

4. Results and discussion

4.1. ANALYSIS RESULTS IN THE BASELINE MODEL

In the research, first, the designed zone in the baseline model was analyzed by Ladybug tool and the obtained results include 52 objectives in output for IUD and 52 objectives for sIUD. The results were recorded using the Colibri plugin. To analyze the simulated model, the Open Studio component has been used in this research. The results obtained from the light analysis in

ENERGY AND DAYLIGHT PERFORMANCE OPTIMIZATION OF BUTTERFLY INSPIRED INTELLIGENT ADAPTIVE FACADE

baseline model indicate that the sIUD index contains a value equal to 60% of the total measured points and this means that 10% out of the total number of sensors had light reception more than 50% of the average. In Figure 4, you see the analysis results of the 21st day of the 3rd month, which is related to spring equinox. Energy analysis in the present study was first analyzed in baseline model in Ladybug tool environment, obtained results include 52 objects at the output for cooling energy load, and 52 objects for heating energy load, and 52 objects for EUI. The results were recorded using the Calibri plugin and then transferred to Excel software for analysis in form of a .csv file. Obtained results from the energy analysis of the baseline model show that the average energy consumption in the total analyzed days before applying the facade is equal to 2/02 KWh/m².

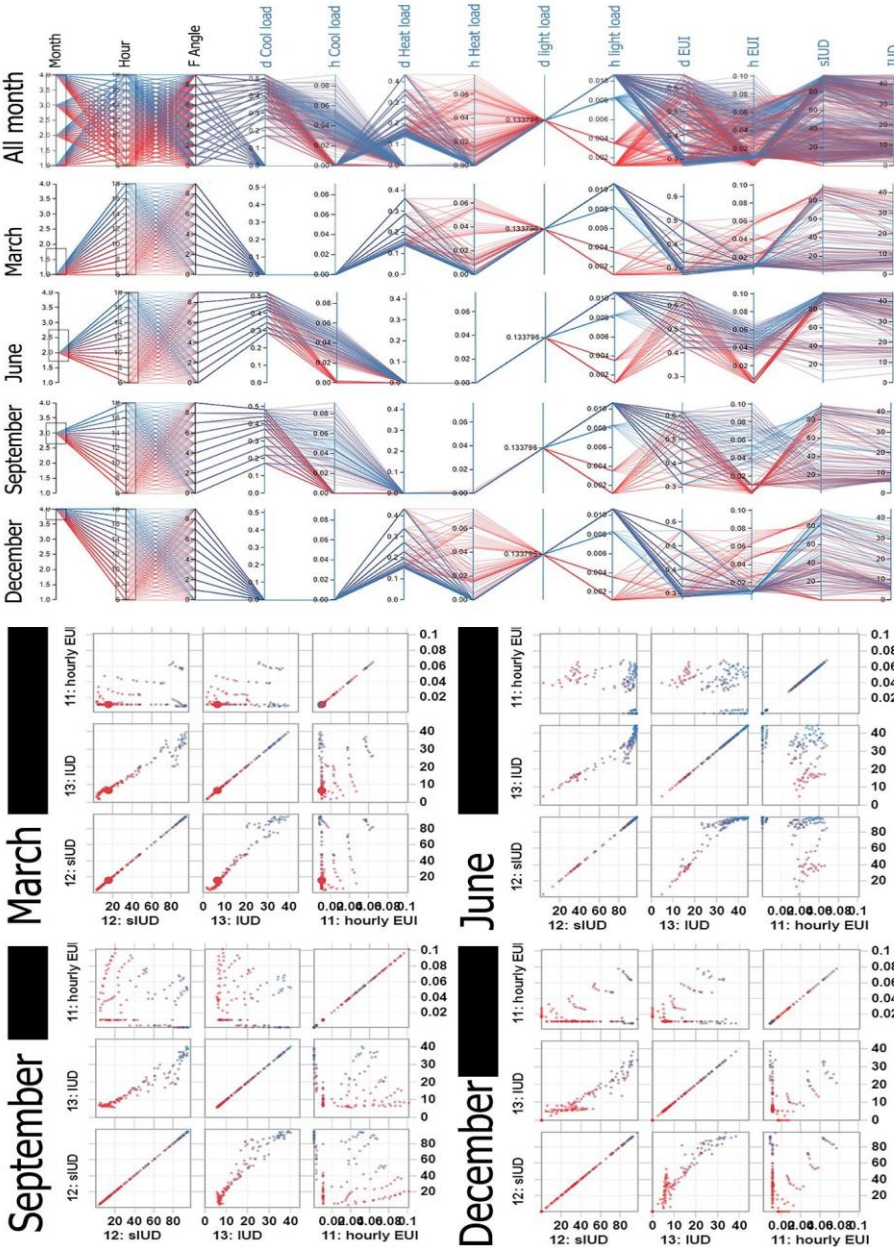

Figure 3. Analysis of illuminance and energy results in Explorer Design environment.

ENERGY AND DAYLIGHT PERFORMANCE OPTIMIZATION OF BUTTERFLY INSPIRED INTELLIGENT ADAPTIVE FACADE

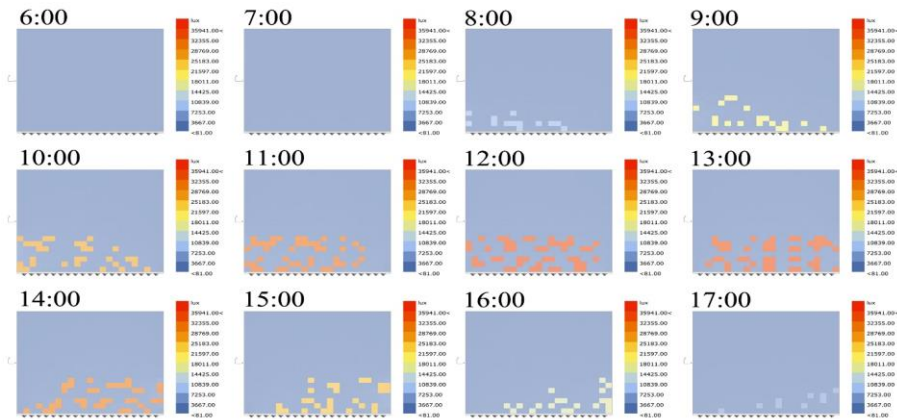

Figure 4. Results from illuminance analysis in the baseline model.

4.2. ENERGY ANALYSIS COMPARISON RESULTS IN THE BASELINE MODEL AND RESEARCH MODEL

In Figure 5, you see illustration of energy analysis results. Results shows the value of 2/02 KWh/m² and you see the average consumption in the most optimal cases in the analysis, which shows the amount of energy consumption up to 1/26 KWh/m², it can be inferred from results in energy analysis findings that the designed facade can reduce energy consumption up to 37/5%. In Figure 5, you see a comparison of the simulation results in the baseline model and the best-received responses from the EUI index.

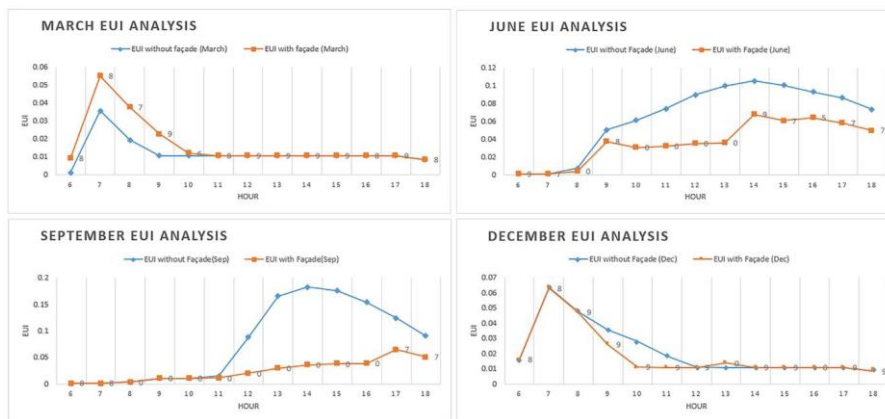

Figure 5. Comparison diagrams of EUI index in the baseline model and research model.

4.3. COMPARISON RESULTS OF ILLUMINANCE ANALYSIS IN THE BASELINE MODEL AND RESEARCH MODEL

The illuminance analysis comparison results in two states with the facade and without facade application, the percentage average of sIUD in baseline model is 60, and this value has increased to 68, in research model, which indicates an improvement in light scattering. The rate of improvement of the sIUD index in research model shown equal to 8/14, in some cases where only the sIUD index is measured, the applied smart facade can increase the optical efficiency amount up to 13/47%. In Figure 6, you see a comparison of the simulation results in the baseline model and the best-received responses from the sIUD index.



Figure 6. Comparison diagrams of sIUD index in the baseline model and research model.

5. Conclusion

The purpose of this study was to investigate the effect of smart facades on reducing energy consumption and illuminance efficiency in cold and dry climates, optimization method was selected from multi objective type, the first priority in simulation and analysis stages was to reduce energy consumption, in the second priority, the role of designed facade was placed on increasing the uniformity of illuminance scattering in office environments, considering the second priority is because all the taken arrangement to reduce energy consumption are done with the aim of providing comfort to residents, for this reason, among all the existing standards, the EN-12464-1 standard was chosen as a reference for the comfort of residents in office spaces and among all indicators in this standard, IUD index was considered as a illuminance scattering uniformity measure, as regards, considering that this index was defined only for illuminance scattering measure on the surface of a person's bench, in continuation of this research, a new index was defined that shows the

ENERGY AND DAYLIGHT PERFORMANCE OPTIMIZATION OF BUTTERFLY INSPIRED INTELLIGENT ADAPTIVE FACADE

uniformity of illuminance scattering in entire work space, this index was defined as sIUD, and was used to analyze the designed facade in research process. Another indicator that was used in this study to analyze the energy calculation of cooling and heating space energy consumption is EUI. All outputs in this study were done hourly in 4 sample days, which include midwinter and midsummer and spring and autumn equinox from 6:00 A.M. to 6:00 P.M., the analyzed facade was changeable in 10 different states every hour and the best of these 10 states was considered to optimized illuminance and energy. In total 52 states were performed for illuminance analysis without facade application were used as a baseline model to compare with results after facade application or the same research model. 520 states were simulated for illuminance analysis in the research model and 520 states for energy analysis. The obtained results from the analysis of office space in baseline model and research model show 8/14% increase in sIUD index, which indicates an improvement in illuminance distribution uniformity in the simulated office space, and also in energy analysis the results show 37/59% decrease in EUI index, which this energy consumption reduction means the high efficiency of smart facades in cold and dry climates, which was selected as a case study in Hamadan city. According to the hypotheses of this research, the designed facade in Hamadan climate has energy efficiency and high-efficiency illuminance approach and it can be introduced as an optimal energy consumption model in a cold and dry climate.

References

- ATTIA, SHADY et al. 2015. "Adaptive Façades System Assessment: An Initial Review." 10th Conference on Advanced Building Skins (November): 1275–83. [https://orbi.ulg.ac.be/bitstream/2268/187576/1/Attia_Adaptive Façades System Assessment An initial review_v05.pdf](https://orbi.ulg.ac.be/bitstream/2268/187576/1/Attia_Adaptive_Façades_System_Assessment_An_initial_review_v05.pdf).
- BAROZZI, MARTA, JULIAN LIENHARD, ALESSANDRAN ZANELLI AND CAROLMONTICELLI. 2016. "The Sustainability of Adaptive Envelopes: Developments of Kinetic Architecture." *Procedia Engineering* 155: 275–84. <http://dx.doi.org/10.1016/j.proeng.2016.08.029>.
- BIAN, YU, TIANXIANG LENG and YUAN MA. 2018. "A Proposed Discomfort Glare Evaluation Method Based on the Concept of 'Adaptive Zone.'" *Building AND Environment* 143: 306–17. <https://doi.org/10.1016/j.buildenv.2018.07.025>.
- BUENO, BRUNO, JOSE MANUEL CEJUDO LOPEZ, ANGELINA KATSIFARAKI AND HELEN ROSE WILSON. 2018. "A Systematic Workflow for Retrofitting Office Façades with Large Window-to-Wall Ratios Based on Automatic Control and Building Simulations." *Building and Environment* 132(January): 104–13.
- COMPAGNON, R. 1997. "<Compagnon97_RadianceTutorial.Pdf>."
- ELTAWHEEL, AHMAD AND YUEHONG SU. 2017. "Parametric Design and Daylighting: A Literature Review." *Renewable and Sustainable Energy Reviews* 73(December 2016): 1086–1103.

- FREEWAN, AHMED A.Y., AND JACKLINE A. AI DALALA. 2020. "Assessment of Daylight Performance of Advanced Daylighting Strategies in Large University Classrooms; Case Study Classrooms at JUST." *Alexandria Engineering Journal* 59(2): 791–802. <https://doi.org/10.1016/j.aej.2019.12.049>.
- HAFIZ, DALIA. 2015. "Daylighting, Space, and Architecture: A Literature Review." *Enquiry A Journal for Architectural Research* 12(1): 1–8.
- HOPKINSON, R. G. 1972. "Glare from Daylighting in Buildings." *Applied Ergonomics* 3(4): 206–15.
- LOONEN, R. C.G.M., M. TRČKA, D. C6STOLA, AND J. L.M. HENSEN. 2013. "Climate Adaptive Building Shells: State-of-the-Art and Future Challenges." *Renewable and Sustainable Energy Reviews* 25(2013): 483–93.
- LYNCH, BRIAN M et al. 2013. "Thermal Environmental Conditions for Human Occupancy." ASHRAE Standard 7(55).
- NAGY, ZOLTAN et al. 2016. "The Adaptive Solar Facade: From Concept to Prototypes." *Frontiers of Architectural Research* 5(2): 143–56. <http://dx.doi.org/10.1016/j.foar.2016.03.002>.
- PANOPOULOS, K., AND A. M. PAPAPOPOULOS. 2017. "Smart Facades for Non-Residential Buildings: An Assessment." *Advances in Building Energy Research* 11(1): 26–36.
- PARK, CHEOL-SOO et al. 2003. "Occupant Responsive Optimal Control of Smart Façade Systems." Eighth International IBPSA Conference (May): 1009–16.
- PESENTI, MARCO, GABRIELE MASERA, FRANCESCO FIORITO, AND MICHELE SAUCHELLI. 2015. "Kinetic Solar Skin: A Responsive Folding Technique." *Energy Procedia* 70: 661–72. <http://dx.doi.org/10.1016/j.egypro.2015.02.174>.
- RODRIGUEZ, R G, A RUIZ, A E PATTINI, AND J A YAMIN GARRET. 2014. "Degree of Eye Opening : A New Discomfort Glare Indicator."
- RUCK, N; ASCHEHOUG, OE; AYDINLI, S. 2000. "ETDE Web."
- SADEK, AHMED H., AND REWAA MAHROUS. 2018. "Adaptive Glazing Technologies: Balancing the Benefits of Outdoor Views in Healthcare Environments." *Solar Energy* 174(September): 719–27. <https://doi.org/10.1016/j.solener.2018.09.032>.
- SHANKS, KATIE, S. SENTHILARASU, RICHARD H. FRENCH-CONSTANT, AND TAPAS K. MALLIK. 2015. "White Butterflies as Solar Photovoltaic Concentrators." *Scientific Reports* 5: 1–10.
- SOFLAEI, FARZANEH, MEHDI SHOKOUHIAN, HOSSEIN ABRAVESHDAR, AND ALI ALIPOUR. 2017. "The Impact of Courtyard Design Variants on Shading Performance in Hot- Arid Climates of Iran." *Energy and Buildings* 143: 71–83. <http://dx.doi.org/10.1016/j.enbuild.2017.03.027>.
- SUK, JAE YONG, MARC SCHILER, AND KAREN KENSEK. 2016. "Absolute Glare Factor and Relative Glare Factor Based Metric: Predicting and Quantifying Levels of Daylight Glare in Office Space." *Energy and Buildings* 130: 8–19. <http://dx.doi.org/10.1016/j.enbuild.2016.08.021>.
- T. TOMASETTI. 2017. "Design Explorer." <http://tt-acm.github.io/DesignExplorer>.
- TECHNICAL COMMITTEE CEN/TC 169 "Light and Lighting." 2002. "Light and Lighting - Lighting of Work Places - Part 1: Indoor Work." *European Standard* 3: 1–43. [file:///C:/Users/amira/Downloads/I.S.EN12464-1-2002 \(5\).pdf](file:///C:/Users/amira/Downloads/I.S.EN12464-1-2002%20(5).pdf).
- USGBC. 2016. "LEED v 4 for BD and C.": 113–65. <http://dx.doi.org/10.1016/B978-0-12-803830-7.00004-9>.
- WAGIMAN, K. R., AND M. N. ABDULLAH. 2018. "Lighting System Design According to Different Standards in Office Building: A Technical and Economic Evaluations." *Journal of Physics: Conference Series* 1049(1).Y

D1.P1.S2

EMERGENT MODES OF LEARNING I

IMMERSIVE VR ENVIRONMENT FOR CONSTRUCTION DETAILING EDUCATION: BIM APPROACH

M. ELGEWELY, W. NADIM, M. TALAAT, A.KASSED, M.YEHIA
German University in Cairo (GUC), 5th settlement, New Cairo, Egypt.
maha.elgewely@guc.edu.eg, wafaa.nadim@guc.edu.eg,
mostafa.talaat@guc.edu.eg, akassed@gmail.com,
myehiah@gmail.com

AND

S.ABDENNADHER
slim.abdennadher@guc.edu.eg

Abstract. According to literature in education, adults learn best when learning is active, self-directed, problem-based, and relevant to their needs. In Building Construction Education, construction site visits provide students with real-life practical experience which are considered an extension for classroom. Nevertheless, it is challenging to integrate construction site visits regularly during the academic semester with respect to the class specific needs. Virtual Reality as an interactive immersive technology may facilitate virtual construction site that meets the learning needs where students can explore and build in a real scale environment. The proposed VR environment is an HMD VR platform for construction detailing that provides experiential learning in a zero-risk environment. It builds on integrating VR technology as a medium and Building Information Modeling (BIM) as a repository of information. This work discusses the proposed environment curricular unit prototype design, implementation, and validation. System usability and immersion are assessed both qualitatively and quantitatively. After considering the feedback, The VR environment prototype is then validated on the level of learning outcomes, providing the evidence that it would enhance students' engagement, motivation and achievement accordingly.

Keywords: *Building construction education, BIM, human computer interaction, interactive learning environments, virtual construction site, and Virtual reality.*

IMMERSIVE VR ENVIRONMENT FOR CONSTRUCTION DETAILING

ملخص. تعتبر الزيارات الميدانية لمواقع البناء من أهم ما يساعد طلاب العمارة وتشبيد المباني على ربط ما يدرسونه بشكل نظري بالواقع مما يعزز فهم الطلاب لممارسات البناء ويعرفهم بمتطلبات الصناعة، ويوفى أيضا بطرق التعلم النشطة والرابطة بالحياة العملية والقائمة على حل المشكلات. ومع ذلك، فإن تلك الزيارات تعتبر محدودة، وتعرض الطلاب للمخاطر؛ أثناء تلك الزيارات الميدانية لمواقع الإنشاء. ومع تقدم تكنولوجيا المعلومات، تستخدم نماذج المباني المعززة بالمعلومات المعروفة كأساس معياري في صناعة إنشاء المباني، كمصدر معلوماتي هام في مجال تعليم العمارة والعلوم الهندسية والإنشاء. وإضافة إلى ذلك، فإن تكنولوجيا الواقع الافتراضي، بوصفها أداة تفاعلية وتعمل على اندماج المستخدم في بيئات شبيهة حقيقية، فضلا عن توافقها مع نظام نماذج المباني المعززة بالمعلومات، تنطوي على إمكانية جلب موقع البناء إلى غرف الدراسة من خلال توفير أداة تعليمية تقنية، توفر بيئة انغماسية بالأبعاد الحقيقية ومعززة بالمعلومات. الهدف الرئيسي من هذا البحث هو تعزيز تجربة التعلم الخاصة بتطوير التفاصيل الإنشائية وتحسين نتائج العملية التعليمية لطلاب العمارة، عن طريق دمج تقنيات الواقع الافتراضي بالإضافة إلى تقنية النمذجة المعلوماتية للمباني كمصدر للمادة العلمية، وذلك لتيسير التعلم التجريبي للطلاب، وذلك من خلال تصميم وتطوير بيئة افتراضية تعمل كنظام مساعد لتعليم التفاصيل المعمارية لتشبيد المباني. وأخيراً، لقد خضعت البيئة الافتراضية المشار إليها للاختبار على عدة مراحل، لكل منها هدفها ونتائجها في تقييم واعتماد البيئة الافتراضية المصممة كنظام مساعد في العملية التعليمية. وقد أشارت النتائج إلى 30% نسبة تحسن في مخرجات التعلم في المتوسط لدى المتطوعين من الطلاب لتجربة النموذج المطور وهو ما يسلط الضوء على قدرات هذا النظام على تحسين اندماج وانغماس الطلاب في التعلم وبالتالي تحسين النتائج التعليمية.

الكلمات المفتاحية: تعليم تشبيد المباني، الواقع الافتراضي، نماذج المباني المعززة بالمعلومات، مواقع البناء الافتراضية.

1. Introduction

The provision of the right skills to prepare the students to practice has always been a heated discussion worldwide with the built environment education; and the architecture education is no exception. With the increasing urbanization rates, the increasing complexity of buildings, wide range of materiality, and technologies used etc.; equipping the students with the appropriate skills has become a challenging proposition. Text books rely largely on 2D details which would require a lot of imagination from the students, which may not be sufficient to grasp due to the complexity of the detail.

While site visits may be an important integral valuable component of architecture education; nevertheless, the inclusion of site visits within a course schedule is not always feasible due to unavailability of construction sites meeting the intended learning outcomes (ILOs) (Haque et al., 2005), time conflicts, large class sizes, and safety issues. Based on a research survey on a number of construction programs in USA universities, graduates have had either none, one or two site visits for each construction core subject areas taught throughout their careers (Pereira et al., 2017). In this respect, the need for supplementary methods to allow experiential learning; and further to

compensate for the inability to fully benefit from real construction site visits becomes persistent.

2. Virtual Construction Site

Immersive technologies are being introduced into gamification, game enhanced learning, and pure education (Shavinina, 2013). The exponentially increasing publications in the field of VR in education (Liu et al., 2017) prove that it enhances students understanding helping them to learn by doing and engaging learners in a learning environment close to reality (Blazauskas et al., 2017; Merchant et al., 2014). Nevertheless, pedagogical approach should drive VR educational applications in order to fulfill the educational goals (Liu et al., 2017; Merchant et al., 2014).

One of the significant, yet innovative information technology (IT) applications in built environment education is virtual construction site (Bille et al., 2014). It is a semi- to all-immersive virtual experience that employs some sort of photo/video-graphic medium for construction projects that might be accessible anytime, anywhere by construction students (Pereira et al., 2017). It has been applied in extant literature in several approaches such as time-lapse videos, power point tours, interactive panoramas (Robert et al., 2006) and real time streaming from large construction project sites (Jaselskis et al., 2011) as well as adaptive e-tutorials (Kamardeen, 2014). In addition, virtual construction site has potential to be extended to the construction industry as a training tool for offsite production (Goulding et al., 2012) or construction management (Vries et al., 2004; Austin and Soetanto, 2010).

3. BIM

One of the current advancements in IT is building information modeling. BIM, from a process perspective, is defined as a facility that enables information management throughout the lifecycle of a building (Isikdag, 2015). During such process, a certain structure's real-world elements—for example, slabs, columns, and beams—are represented like objects found in a digital 3D model. While there are many initiatives worldwide to include BIM in AEC education (Ghosh et al., 2013; Sacks and Pikas, 2013); it is argued that BIM visualized models and associated databases has the potential to provide an enhanced platform for education (Clevenger et al., 2012). This has been attributed to its ability to allow information to be readily available in a visual form. In addition, BIM's 4D capabilities enable students to better understand the assembly process through the production of assembly animations (Boon and Prigg, 2011; Le et al., 2015; Gledson and Dawson, 2017; Irizarry et al.,

2012). As a user-friendly, interactive repository of information can extend the learning environment beyond the classroom boundaries, having the potential to considerably enhance the educational experience of students (Irizarry et al., 2012), especially when integrated with other technologies such as VR and AR in different forms (Horne and Thompson, 2007; Gledson and Dawson, 2017).

4. The VR Environment

This research proposes an integrated immersive tool that builds on the VR technology as a visualization and interaction medium, which facilitates active learning through its high capabilities of real-time visualization, compatibility with game engines, and handling different data types. The VR system is a head-mounted display (HMD) VR construction detailing environment which integrates VR technology and BIM where a VR construction site is brought into classrooms with enhanced gamified learning experience providing edutainment environment to motivate learners to gain knowledge. BIM is integrated to support 3D models with technical information that is part of the display and game mechanics.

The aim of The VR system is to work as a technology enhanced learning (TEL) tool that overcomes limited construction site visits and offers a contemporary active way of learning that increases student motivation and adapts to different complexity levels based on the ILOs, and thus to be resilient to accommodate more parameters as needed. In this context, the proposed environment is intended to be a modular expandable system that is able to expand vertically to cover advanced BIM dimensions and horizontally to broaden the tackled topics according to curricula.

4.1. THE VR ENVIRONMENT SYSTEM ARCHITECTURE

The VR environment is intended to support two types of users; namely instructor (desktop interface) and student (VR and desktop interface). Each has their own interface and controls. Based on construction detailing classifications, the system is intended to allow the instructor to determine which approach is most appropriate for the session's objective.

The proposed system composed of three main categories (Elgewely and Nadim, 2020), namely the instructor interface, the student interface, and the core where all the information is processed (Figure 1). The system supports classifications based on materiality, function, or building element which supports information filtration according to course learning outcomes and complexity level.

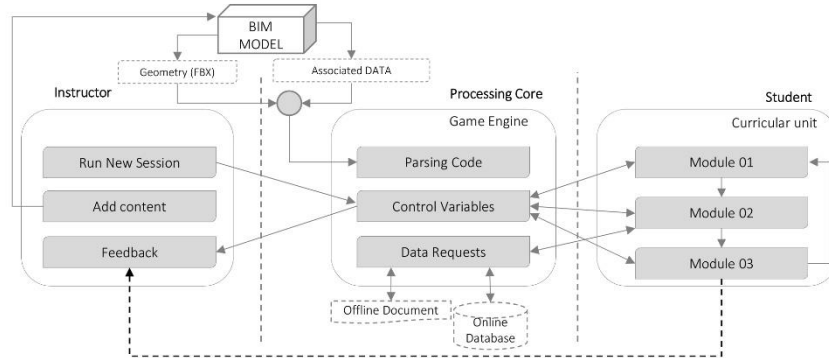

Figure 1. The VR Environment Soft System Methodology.

The system empowers the instructor to add BIM models and associated information. In addition, the system is able to request numeric data from online calculators or offline documents such as environmental data, fire rating, or any other relevant numeric input. Students have customized portals identified by ID that would help in generating the analytics and giving feedback to both the instructor and student with his/her earlier plays and results to point out progress. In the VR environment, a student learns by exploring a BIM real-scale building through teleportation, explode and build a number of construction details. The environment also includes control variables that work as module switchers such as number of collected building materials, exploded details, solved problems, etc.

4.2. CURRICULAR UNIT

The proposed system is supported by a three-level curricular unit, that is designed to follow four methods of construction detailing exercise methods (Allen and Rand, 2016) (Figure 2). Freestyle detailing is not supported as it needs infinite collection of building materials and construction elements as well as constraint database.

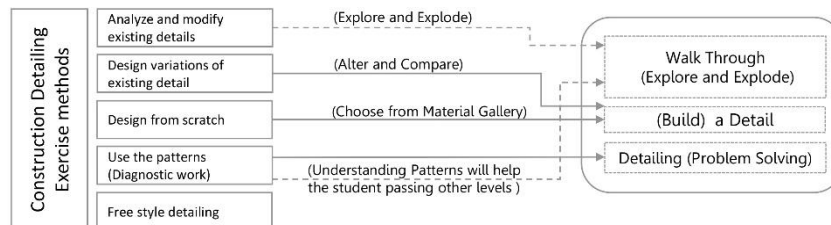

Figure 2. The VR environment curricular-unit Modules to their Corresponding Exercise Method(s).

IMMERSIVE VR ENVIRONMENT FOR CONSTRUCTION DETAILING

In the first module, the student (Walkthrough) a BIM model, explore construction materials as well as explode construction details. The second module enables the student to (Build) a construction detail. Using several components of construction materials. The student gets feedback on the detail performance in different numeric aspects like environmental control, fire rating, etc. The third module of The VR environment curricular unit is (Problem Solving) where the student makes decisions to solve multiple construction problems such as water leakage, stability issues, etc.

4.3. TECHNOLOGY

According to the curricular module design, student has to have the ability to walk through a building and intuitively interact with its components. HTC vive® head-based display VR equipment has been chosen as it fulfills the criteria with its room setting and hand-held controllers in comparison to CAVE systems and mobile-based VR. In addition, multiuser VR experience became possible in HBD through avatars. With regard to the software, Unity3D cross-platform game engine, SteamVR and VRTK software development kits (sdk) were used to develop the VR prototype.

4.4. PROTOTYPE ENVIRONMENT IMPLEMENTATION

A prototype environment has been developed with particular focus on masonry construction. This prototype is designed to be scalable and dynamic to include a wider range of building mock ups, construction topics, building materials as well as complexity levels.

4.4.1. Module 01: Walkthrough (Explode and Explore)

The first module, the student walks through a BIM model, explore construction materials, get technical information, explode few construction connections and explore their components, and understand patterns. Teleportation points are distributed strategically around the building based on SteamVR predefined interaction system (Figure 3).

Associated information to each object is displayed on the users' demand (Figure 4) on a panel attached to the left hand-held controller. In addition, other motivating game elements and challenges are integrated in user experience (UX) design. For example, the student is asked to collect a number of construction materials and read the associated technical information that helps the user to gain knowledge/clues for passing other levels.

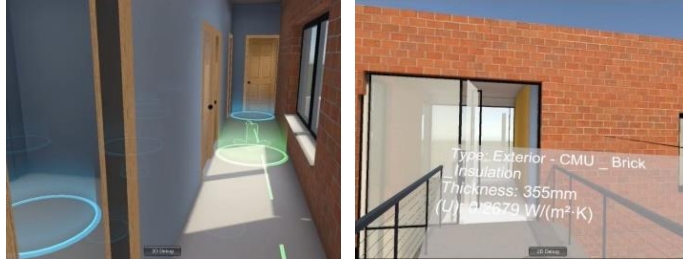

Figure 3. (Left)
Teleportation
Figure 4. (Right)
Info panel

Few explodable spots are highlighted around the building. In case of the walls, the connections are window-wall, wall-foundation, parapet, etc. Each triggered spot contains the correspondent detail fragmented to its components that allow the student to interact with and get information about. After collecting all available construction materials' tokens and visiting all the explosion scenes, the user is allowed to “build” a detail—in this case, a wall.

4.4.2. Module 02: (Build) a Detail

Module 02 allows the student to build a construction detail using different components and construction materials. The instructor controls the detail type, complexity and construction materials available according to the ILOs of the session. The student should be able to choose the various layers or components of the construction detail in order, thus, receives a feedback on the constructed detail in the form of numeric values such as U-Value (heat transfer indicator) or fire rating and constructability deficiencies extracted from BIM constraint and conflict detection; given the chance to edit, compare and restart. With specific focus on masonry wall detailing, students are able to design and build wall layers to achieve optimized thermal performance. Three interaction functions are included in module 02:

- Construction material selection through a collection of categorized wall construction materials supported by an information panel (Figure 5).
- Placement materials, representing detail/wall layers, in six layer slots (Figure 6) that facilitate flexible modification.
- Assembly of the detail components, and getting instant feedback on deficiencies (if any) in addition to thermal resistivity for each material, and the overall U-value.

The (Build) a Detail module is self-exploratory level that also gives the student the chance to mistake, edit, modify and compare the resultant details.

4.4.3. Module 03: Detailing (Problem Solving)

In the problem-solving level, the student meets multiple technical problems building a construction detail that are required to be solved. In the case of

IMMERSIVE VR ENVIRONMENT FOR CONSTRUCTION DETAILING

masonry walls, problems might reflect water leakage or stability problem. The clues to solve these issues are the collectibles that a student has met previously

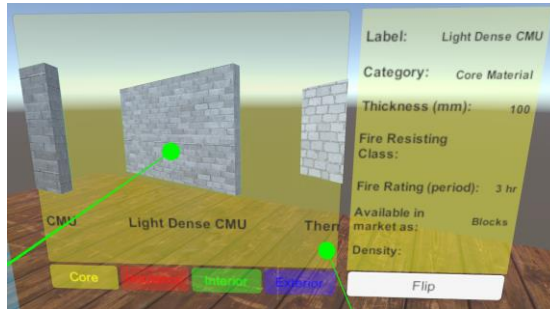
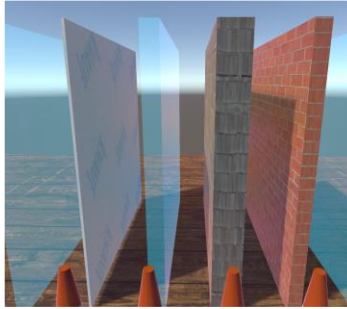
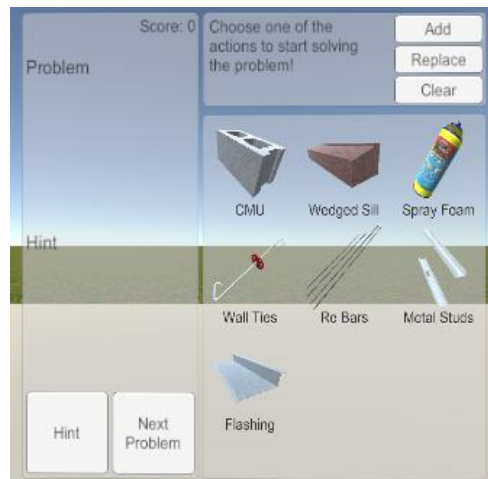

Figure 5. Wall layers placement slots Figure 6. Material gallery

The student employs the collected materials to fix the challenge in hand either by adding or replacing components with drag and drop interaction. With increasing complexity, a student meets multiple construction problems as needed.

Figure 7. Problem Solving Panel



5. Validation

The developed prototype, which includes only wall components-related data, is a user-friendly demo modules that make it possible to validate students' learning outcomes and learning experience. The validation aims to test the user friendliness and test the extent to which the VR environment helped improve students' comprehension and understanding of construction detailing. The validation of The VR environment was conducted on three phases, namely, piloting, testing, and learning gain validation, each of which has its aim and outcomes.

5.1. VALIDATION METHODOLOGY

Piloting took place throughout the development, starting from self-testing, students, VR experts, architecture instructors as well as nonexperts in either VR or architecture, with the aim to test proof errors, examine VR experience, and identify key features that may have been missed during the development before fully develop the learning tool and validate it on larger groups.

UX Testing phase is intended to get feedback on challenges to resolve. In order to get discrete feedback on each game level, Walkthrough module and Build a wall module have been tested separately, each on two different groups of students, to achieve both qualitative and quantitative feedback on both usability and immersion of the corresponding prototype module (Figure 8). Problem solving module has been developed using the same interaction features and spatial experience following the other modules. Due to time limitations, it didn't undergo the validation process.

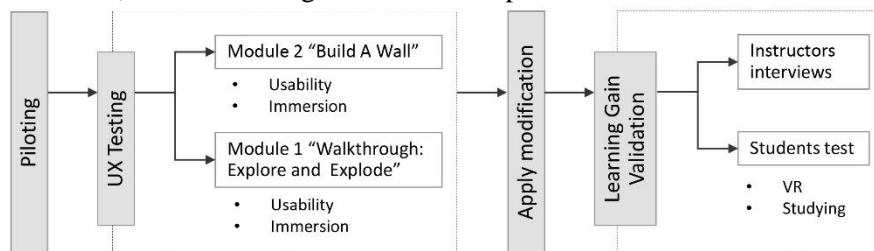

Figure 8. Validation Methodology

Usability has been assessed both qualitatively by conducting System Usability Scale (SUS) standardized questionnaire (Brooke, 1996) has been conducted to give feedback on effectiveness, efficiency as well as user satisfaction. As usability scales are not diagnostic and not designed specifically for VR applications, a personalized questionnaire was essential in order to evaluate certain features' friendliness to the users. Furthermore, each module has been assessed qualitatively by observation of users' behaviour during testing sessions and unstructured feedback after the VR experience. Module 01 and 02 have been tested for usability on a convenience sample of 13 and 10 volunteered architecture students.

In order to assess the VR prototype in terms of sense of presence, standardized Igroup Presence Questionnaire (IPQ) (Schubert et al., 2001) was conducted on each module separately to measure immersion level. By assessing spatial presence (SP), Involvement (INV) and experienced realism (REAL), retrieving average score/6. Immersion test has been conducted on two groups which consisted of 12 and 10 architecture and nonarchitecture volunteered students for the "walkthrough" module and "build a wall" module respectively. All volunteers were introduced to a VR interaction tutorial before experiencing VE for 13 to 15 minutes.

Based on the results of the UX testing, modifications are implemented on the VE. A revised version of VR prototype environment underwent two levels of learning gain validation; namely instructor level and student level. Two building technology professors were interviewed to give feedback on the content, interface, and system feedback whereas a focus group of fresh-eye

IMMERSIVE VR ENVIRONMENT FOR CONSTRUCTION DETAILING

architecture students (Group A) was tested before and after experiencing VR with specific focus on their learning gain. Their learning outcome progress is compared to the learning outcome progress of another correspondent paper-based-studying focus group (Group B). Both groups are volunteering architecture fourth semester students, 16 and 15 students respectively.

5.2. UX TESTING RESULTS

SUS questionnaire retrieves 78.04 and 78.5 percentile for module 01 and 02 respectively which indicates close successful interaction methods for both modules. Usability personalized questionnaire for module 01 is composed of 21 questions; five are personal questions that may indicate users' background and familiarity with VR technology. The questionnaire also inquire about interface controls consistency, teleportation and navigation, collectibles, information display and explosion scenes.

The personalized questionnaire and the qualitative feedback indicate few deficiencies that needed to be optimized before the learning gain validation such as, text overlap, minor teleportation problems, uncomfortable areas, colliders' deficiencies, collectibles behaviour, controls difficulties, etc.

In addition to the personal information section, usability personalized questionnaire for module 02 contains questions about controls smoothness, components placement mechanism, spatial perception, and interaction features (i.e. assembly button physical interaction). According to the personalized questionnaire and qualitative feedback that has been recorded by observation and unstructured feedback few difficulties were noted through observation with gallery menu navigation and object instantiation, discomfort for the users against real-scale instantiated wall layers, as well as their location and colliders was noted, which was reconsidered in the modification phase.

With regards to Immersiveness, IPQ test Module 01 scored 5.3, 4.2, 3.4 and 2.9 in general presence, spatial presence, involvement, and realness respectively whereas module 02 scored 5.6, 4.9, 4.5 and 3.7 in general presence, spatial presence, involvement, and realness respectively (Figure 9) which indicates acceptable immersion levels of both modules. Only realness factor of the walkthrough level scored slightly below 3. As a limitation for real-time rendering environments, lighting and rendering qualities are usually reduced in order to optimize real-time calculations for better speed and lagging avoidance.

5.3. UX TESTING ANALYSIS AND ACTIONS

In light of the UX testing results, problems were classified into categories that require certain actions that should be taken before the learning gain validation of the tool and future recommendations that can be implemented later. Accordingly, actions were taken with regards to animating collectibles to enhance their visibility, fix unclear controls labelling, modifying teleportation

points positioning and permeability of few objects to give the space a sense of extension and provide easier interaction.

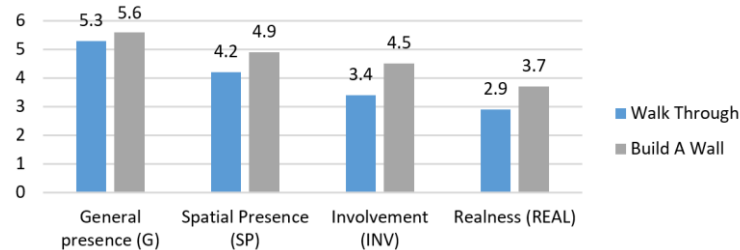

Figure 9. IPQ test results – module 01 vs. module 02

5.4. LEARNING GAIN VALIDATION

Learning gain validation was conducted on a refined version of the VE after implementing modifications resulted from UX testing, on two levels namely; students test and instructors interviews. The main aim of this test phase was to validate the effectiveness of The VR environment as a computer assisted tool for learning that can enhance learning outcomes as well as a learning experience for construction detailing education.

5.4.1 Students Test

The students' learning gain test was conducted on two samples of convenience were volunteering architecture students from a pool of sample decided according to the complexity level of the developed prototype content, which in this case, 4th semester students.

Students' learning progress is measured by testing them before and after experiencing the VR prototype for group A and studying for group B. Pre-and post-tests were piloted to make sure both have the same complexity level yet challenging enough to be able to measure the real progress if any. Building technology section assesses materiality, construction, and problem solving, while thermal performance section assesses the student's ability to relate materiality and thermal performance of the wall. Moreover, pre-test of group A included three questions about the students learning style, prior experience with VR, and familiarity with video games.

The results indicated 30% progress average for group A (VR) for both test sections vs. 13.8% for group B (Studying). Furthermore, group A students achieved 33.125% and 23.75% progress average for building technology and thermal performance sections, respectively. In addition, there was no significant difference in progress between hardcore gamer students and their less experienced colleagues. As part of the learning gain validation, user satisfaction was evaluated on a 5-point scale, customized questionnaire that measures the acceptance of the VE as a technology enhanced learning tool

IMMERSIVE VR ENVIRONMENT FOR CONSTRUCTION DETAILING

among students, the ability of the system to allow visualizing and conducting the learning materials, the capacity to provide edutainment environment, and finally acceptance of users to be assessed or solve problems through the VR environment to assess understanding. Results reflect high acceptance among students of VR method of learning as well as satisfaction about the VR prototype environment (Figure 10).

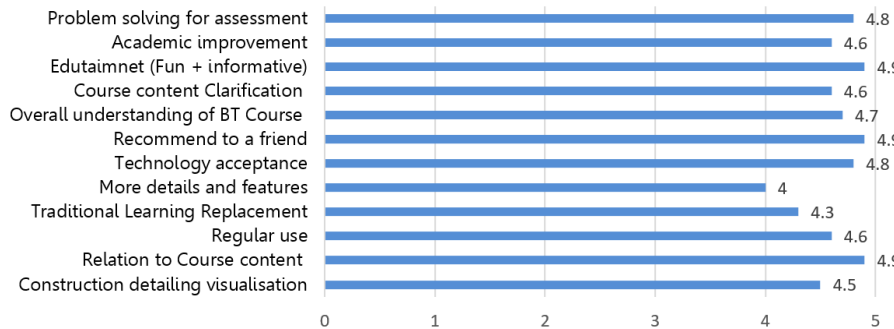

Figure 10. User satisfaction customized questionnaire

5.4.2 Instructors Interviews

Two building technology professors were available for interview to gauge to extent to which the VR developed environment would help support their courses. After a ten-minute presentation to explain the concept, system architecture and methodology, instructor feedback and interface, and finally the prototype structure, each professor was able to experience the VR prototype; then they were asked to give their feedback through a semi-structured interview that included open-ended questions. The main aim is to assess the concept, prototype content, learning experience, instructor user interface in addition to discuss future development recommendations.

The interviewee professors confirmed the low rate of site visits which makes the students detached, to an extent, from the construction industry. As a compensation, the proposed environment can play a role in bridging this gap. Although, one of the professors stated that real site visits are more valuable; he found “build a wall,” with its quantifiable feedback, to be beneficial for students. In addition, both professors see the quantifiable feedback is useful. After trying the VR prototype, they found the learning environment is interesting for the students, yet it needs improvement with regard to architecture quality. In terms of the content/learning material, professors recommend to integrate more parameters to control the material such as adjusting wall thickness, testing other building typologies, consider construction sequence as well as include non-standard details. Furthermore, they proposed several ideas to be implemented in the future, such as a 3D detailing catalogue, a database for senior students’ entries, real-time protocol

with BIM platforms where user builds in real time using the BIM constraints; in addition to increasing complexity by adding more aspects such as life cycle feedback, CO2 emissions, and other quantifiable data.

6 Study Results

Validation results indicate high acceptance of the developed VE among students as a learning-aid tool supported by appropriate level of visualization and conduction of learning materials as it succeeded to provide an active learning environment that is informative and entertaining at the same time.

Learning outcomes test indicated more than double average progress for group A (VR) over group B (studying), respectively which confirms efficiency of active learning in general and VR in particular to enhance the learning experience and learning outcomes. In terms of the educators' feedback, although they found the VR environment useful for their students, they proposed using it as a stand-alone experience in the framework of an open platform. Furthermore, generally most of the comments were suggestions which already taken into consideration in the system architecture but were not included in the VR prototype due to time constraints. Nevertheless, their feedback and eagerness to give more suggestions, may be considered as an indication for their positive impression and acceptance to have a VR tool to improve building technology learning experience.

6.1. THE VR SYSTEM AS A MAINSTREAM

BIM integrated virtual construction site as a concept is expected to be widely applied in the very near future to be a mainstream in AEC education, as well as a decision support system for project and construction management. On the other hand, adopting the new technology naturally implies adapted ways of teaching and prepared materials which requires extended agreements between academia and industry to employ real projects documentation in the educational process. In addition, applying the VR system as a mainstream has few challenges such as time consumed in preparing new teaching materials and qualifying trainings for construction educators to integrate such new technology. In this essence, endeavours of capacity building on the scale of universities and architecture and construction firms are expected to be increased fostering the up-to-date technology.

7. Conclusion

The research at hand adopts integrating BIM in AEC educations by proposing a system that can work as a main stream complementary construction detailing

IMMERSIVE VR ENVIRONMENT FOR CONSTRUCTION DETAILING

learning method for architecture students. BIM integrated virtual construction site as a concept is expected to be widely applied in the very near future to be a mainstream in AEC education, and also in industry as a decision support system for project and construction management. This paper is proposing a VR system for construction detailing education which integrates potentials of both immersive VR and BIM as a source of data. The proposed system has been validated on the level of usability, immersion and learning outcomes.

Validation results confirm that virtual reality is an effective and motivating educational medium that apparently enhances the students' learning experience and learning outcomes in comparison to traditional paper based studying. Results also indicate VR acceptance among educators as an educational medium. However, it is challenging to apply The VR environment as a mainstream or regular classes.

References

- ALLEN, E. AND RAND, P., 2016. *Architectural detailing: function, constructibility, aesthetics*. John Wiley & Sons.
- AUSTIN, S. AND SOETANTO, R., 2010. The use of ACT-UK Virtual Reality Simulation Centre to enhance the learning experience of undergraduate building students. *engineering education*, 5(1), 2-10.
- BILLE, R., SMITH, S.P., MAUND, K. AND BREWER, G., 2014, December. Extending building information models into game engines. In *Proceedings of the 2014 conference on interactive entertainment*, 1-8.
- BLAZAUSKAS, T., MASKELIUNAS, R., BARTKUTE, R., KERSIENE, V., JURKEVICIUTE, I. AND DUBOSAS, M., 2017, October. Virtual reality in education: new ways to learn. In *International Conference on Information and Software Technologies*, 457-465. Springer, Cham.
- BOON, J. AND PRIGG, C., 2011. Releasing the potential of BIM in construction education. In *Management and Innovation for a Sustainable Built Environment MISBE 2011*, Amsterdam, The Netherlands.
- BROOKE, J., 1996. SUS: a "quick and dirty" usability. *Usability evaluation in industry*, 189.
- CLEVENGER, C., GLICK, S. AND DEL PUERTO, C.L., 2012. Interoperable learning leveraging building information modeling (BIM) in construction education. *International Journal of Construction Education and Research*, 8(2), 101-118.
- D. VRIES, B. S. VERHAGEN, AND A. J. JESSURUN., 2004. Building management simulation centre. *Automation in Construction* 13, no. 5, 679-687.
- ELGEWELY, M. AND NADIM, W., 2020. Immersive Virtual Reality Environment for Construction Detailing Education Using Building Information Modeling (BIM). In *The 10th International Conference on Engineering, Project, and Production Management*, pp. Springer, Singapore, 101-112.
- GHOSH, A., CHASEY, A.D. AND ROOT, S., 2013, April. Industry and academia: A partnership to VDC curriculum. In *49th Associated schools of construction annual international conference proceedings*.
- GLEDSON, B.J. AND DAWSON, S., 2017. Use of simulation through BIM-enabled virtual projects to enhance learning and soft employability skills in architectural technology

M. ELGEWELY, W. NADIM, M. TALAAT, A.KASSED, M.YEHIA AND
S.ABDENNADHER

- education. In *Building Information Modelling, Building Performance, Design and Smart Construction*. Springer, Cham, 79-92.
- GOULDING, J., NADIM, W., PETRIDIS, P. AND ALSHAWI, M., 2012. Construction industry offsite production: A virtual reality interactive training environment prototype. *Advanced Engineering Informatics*, 26(1), 103-116.
- HAQUE, M.E., ALUMINIUMWALLA, M. AND SAHERWALA, S., 2005. A virtual walkthrough on reinforced concrete construction details. In *Proceedings of American Society for Engineering Education Annual Conference & Exposition*.
- HORNE, M. AND THOMPSON, E.M., 2007, October. Virtual Reality and 3D modelling in built environment education. In *7th Conference on Construction Applications of Virtual Reality*, 22-23.
- IRIZARRY, J., MEADATI, P., BARHAM, W.S. AND AKHNOUKH, A., 2012. Exploring applications of building information modeling for enhancing visualization and information access in engineering and construction education environments. *International Journal of Construction Education and Research*, 8(2), 119-145.
- ISIKDAG, U., 2015. Enhanced building information models. *SpringerBriefs in Computer Science*, 577-590.
- JASELSKIS, E., RUWANPURA, J., BECKER, T., SILVA, L., JEWELL, P. AND FLOYD, E., 2011. Innovation in construction engineering education using two applications of internet-based information technology to provide real-time project observations. *Journal of construction engineering and management*, 137(10), 829-835.
- KAMARDEEN, I., 2014. Adaptive e-tutorial for enhancing student learning in construction education. *International Journal of Construction Education and Research*, 10(2),79-95.
- LE, Q.T., PEDRO, A. AND PARK, C.S., 2015. A social virtual reality based construction safety education system for experiential learning. *Journal of Intelligent & Robotic Systems*, 79(3-4), 487-506.
- LIU, D., BHAGAT, K.K., GAO, Y., CHANG, T.W. AND HUANG, R., 2017. The potentials and trends of virtual reality in education. In *Virtual, augmented, and mixed realities in education*, 105-130. Springer, Singapore.
- MERCHANT, Z., GOETZ, E.T., CIFUENTES, L., KEENEY-KENNICUTT, W. AND DAVIS, T.J., 2014. Effectiveness of virtual reality-based instruction on students' learning outcomes in K-12 and higher education: A meta-analysis. *Computers & Education*, 70.
- PEREIRA, R.E., MOUD, H.I. AND GHEISARI, M., 2017. Using 360-degree interactive panoramas to develop virtual representation of construction sites. In *Lean and Computing in Construction Congress (LC3): Volume 1D Proceedings of the Joint Conference on Computing in Construction (JC3), July 4-7, 2017, Heraklion, Greece*, 775-782.
- ROBERT CT, E., IAN, D., CHRISTOPHER, G. AND ADRIAN, R., 2006. Virtualsite: an interface for accessing learning resources. *Journal for Education in the Built Environment*, 1(2), 15-26.
- SACKS, R. AND PIKAS, E., 2013. Building information modeling education for construction engineering and management. I: Industry requirements, state of the art, and gap analysis. *Journal of Construction Engineering and Management*, 139(11).
- SCHUBERT, T., FRIEDMANN, F. AND REGENBRECHT, H., 2001. The experience of presence: Factor analytic insights. *Presence: Teleoperators & Virtual Environments*, 10(3), 266-281.
- SHAVININA, L.V. ED., 2013. *The routledge international handbook of innovation education*. Routledge.

TRANSFORMING LEARNING FOR ARCHITECTURE

Online Design Studio as New Norm for Crises Adaptation under COVID-19

DUAA AL MAANI, SABA ALNUSAIRAT

Architecture Engineering, Applied Science Private University.

Email address: d_almaani@asu.edu.jo

Architecture Engineering, Al-Ahliyya Amman University.

Email address: s.alnusairat@ammanu.edu.jo

AND

AMER AL-JOKHADAR

Architecture Engineering, University of Petra, Amman, Jordan

Email address: amer.aljokhadar@uop.edu.jo

Abstract. For students, studying architecture necessitates a fundamental shift in learning mode and attitude in the transition from school. Beginner students are often surprised by the new mode of learning-by-doing and the new learner identity that they must adopt and adapt to in the design studio. Moreover, due to the COVID-19 pandemic, architecture teaching has moved online. Both instructors and students are experiencing dramatic changes in their modes of teaching and learning due to the sudden move from on-campus design studios to a virtual alternative, with only the bare minimum of resources and relevant experience. This study explored the virtual design studio as a transformative learning model for disaster and resilience context, including the factors that affect foundation students' perceptions and experiences of the quality of this adaptation. Data obtained from 248 students who took online design studios during the lockdown in 15 universities in Jordan highlight many factors that make the experience of the online design studio more challenging. Despite these challenges, strongly positive aspects of the online studio were evident and widely discussed. A model of hyper-flexible design studio in which students can have a direct contact with their instructors when needed – in addition to online activities, reviews, and written feedback – is highly recommended for the beginner years. This HyFlex model will enrich students' learning and understanding of the fundamentals of design and ensure that technology solutions deliver significant and sustainable benefits.

Keywords: virtual learning, online design studio, crises, COVID-19, Transforming learning, sustainable e-learning.

ملخص. تتطلب دراسة الهندسة المعمارية تحولاً أساسياً في نمط التعلم واتجاهاته بعد الانتقال من التعليم المدرسي. فغالبا ما يتفاجأ الطلاب في سنواتهم الأولى بالنمط الجديد لتعلم العمارة بالممارسة و بمسؤوليتهم التعليمية الجديدة التي يجب عليهم تبنيها والتكيف معها في مرسوم التصميم. علاوة على ذلك ، و بسبب جائحة كورونا ، فقد مرّ كل من المدرسين والطلاب بتغيرات جذرية في أساليب التدريس والتعلم بسبب الانتقال المفاجئ من مراسم التصميم داخل الحرم الجامعي إلى بديل سيبراني ، مع الحد الأدنى من الموارد والخبرة ذات الصلة. تطرح هذه الدراسة مرسوم التصميم الافتراضي كنموذج تعليمي تكيفي في الكوارث ، بما في ذلك العوامل التي تؤثر على تجربة الطلاب في سنتهم الأولى بشأن جودة هذا التحول. تُبرز البيانات التي تم الحصول عليها من 248 طالباً ممن شاركوا في مراسم التصميم عبر الإنترنت أثناء الإغلاق في 15 جامعة في الأردن العديد من العوامل التي تجعل تجربة المرسوم التصميم عبر الإنترنت أكثر تحدياً. على الرغم من هذه التحديات ، كانت الجوانب الإيجابية في المرسوم عبر الإنترنت واضحة ونوقشت على نطاق واسع. يوصى بنموذج استوديو التصميم المدمج المرن حيث يمكن للطلاب الاتصال مباشرة بمعلمهم عند الحاجة - بالإضافة إلى الأنشطة عبر الإنترنت والمراجعات والتعليقات المكتوبة - للسنوات المبتدئة. سيثري هذا النموذج المدمج و المرن تعلم الطلاب وفهمهم لأساسيات التصميم ويضمن أن تقدم الحلول التقنية فوائد كبيرة ومستدامة.

الكلمات المفتاحية: المرسوم التصميمي الافتراضي، التعلم الإلكتروني، التعلم الإلكتروني المستدام.

1. Transformative Learning in the Contexts of Disaster and Resilience

There are three models of the learning process in universities (El-Bakry and Mastorakis, 2009): traditional learning, which is based on classes and facial communication between instructors and learners; distance learning, in which instructors and students are separated by time, location, or both; and blended learning, which combines traditional classes with e-learning. Technological advances have allowed rapid forward movement, with web technology employed via the internet to enhance the learning process. Such tools facilitate the rapid exchange of information across distance and to a wider population (Broadfoot and Bennett, 2003).

Online education is seen as a learning model for sustainability that contributes to achieving the UN's sustainable development goals for 2030 (Casanova and Price, 2018). In addition, virtual education is a model of risk management for change in higher education, which is considered the new learning paradigm (Angelou and Economides, 2007; Atkinson, 2015). However, to promote lifelong learning, the key factors for adoption are adaptive and dynamic resilience that are increasingly acknowledged as key components in education (Hall, 2015). The implementation of adaptive and dynamic resilience will ensure that technology solutions deliver significant and sustainable benefits (Atkinson, 2015).

TRANSFORMING LEARNING FOR ARCHITECTURE: ONLINE DESIGN STUDIO AS NEW NORM FOR CRISES ADAPTATION UNDER COVID-19

In recent years, several universities around the world have introduced e-learning as a supplement to or replacement for traditional classrooms (Jati, 2013). However, these online courses are assumed to be well-planned, with educators having prepared their courses in advance of joining the online platform; thus, their contexts are very different to the emergent, ad hoc redevelopment of the teaching model that we have seen during COVID-19.

Most – if not all – educators are dealing with new applications, introduced to them and their students only days before the start of online teaching. Educators and students had different levels of digital fluency and had never before engaged with this type of learning experience.

Moreover, types of learning settings and pedagogical approaches in education determine whether a discipline can be taught via online lecturing. For example, many disciplines in science schools emphasise the need for lab teaching and learning experiences, whereas education in art programmes have largely been based in a studio environment and require face-to-face interaction (Lueth, 2008). Turning to architectural education, it is apparent when analysing literature on virtual design studios that online studios have some pedagogical shortcomings. The question of the adoption of and adaptation to the online design studio as a replacement for the traditional form has been investigated by various researchers and educators over the last decade (Alnusairat *et al.*, 2020; Salama and Wilkinson, 2017; Saghafi *et al.*, 2012; Silva and Lima, 2008). These studies argue that online design studios will not replace the traditional studio in the future and that many of the essential aspects – such as peer-learning – mean that a full online mode simply would not be successful.

Thus, the study explores the extent to which the virtual design studio can achieve the desired outcomes of the physical design studio. Furthermore, it seeks to identify whether there are benefits to this shift towards the new mode of online learning. The study focuses on the learning experiences of foundation-year students and explores the outcomes of the design studio culture, as perceived by the student participants in this study. Although physical outcomes such as the drawings and models produced by the students to fulfil their assignment requirements are important, this study concentrates on the participants' experiential perceptions.

2. The Architectural Design Studio

In architecture, design courses are the core of the programme. In the design studio, students undertake design projects under the supervision of a studio instructor and learn by constructing solutions to design problems, rather than by listening passively to lectures. Schön (1983, 1985, 1987) sees learning design as a process of 'reflection in

action’, in which conversations between the instructor and student have different forms, ranging from the desk tutorial (one-to-one) and the group tutorial to the formal crit/review (jury critique).

Students’ work in the design studio is constantly being assessed through the use of desk reviews, where instructors spend the class time speaking to the students individually about their work at their desks. Student work is also reviewed through public juries, critiques, or reviews. Judges or reviewers are usually either architecture instructors or architects from practice. However, students can also act as reviewers to give feedback on the work produced by their peers for a project.

Dutton (1987) states that design studios, unlike typical classrooms, are active learning environments in which students are engaged socially and intellectually in different sets of activities, such as model-making and drawing, while shifting between analytic, synthetic, and evaluative models of thinking. Moreover, it is a place that offers students an experience and learning culture all of its own. While students are expected to work in the studio space during the official ‘class’ time, many students continue their work in the studio after the designated time. Williams et al. (2007) argue that ‘learning is socially constructed, and architectural practice involves social practice’. This view is supported by many researchers, who point out that the studio appears to be an ideal environment to develop lifelong learning, as it encourages independence, reflective analysis, and critical thinking (Al Maani, 2019; Clune, 2014; McClean, 2009).

In addition to interacting and socialising with their peers, students need to integrate different forms of knowledge and skills as they learn in the design studio. The major sources of this knowledge are the other theoretical courses provided in the educational programme, such as history and theory of architecture, construction, and technology, as well as computer-aided design tutorials. This is in addition to the students’ personal interpretations of and interest in the design brief (Al Maani, 2019). In other words, students learn design by doing, while learning a new formal language, new skills, and architectural thinking (Ledewitz, 1985). Therefore, unlike in the traditional classroom, assessment in the design studio relies not only on the final ‘product’ of the student’s work, but also on the design process undertaken by the student to reach the final product – which requires them to take control of their learning and be confident in their learning ability.

2.1. THE DESIGN STUDIO FOR FIRST- AND SECOND-YEAR STUDENTS

Design courses in the first two years are considered the ABC of any design pedagogy. The journey begins with the basic elements of spatial perception. Such studios have the primary role of initiating creativity and understanding the art and science of design in many forms. It is the students’

TRANSFORMING LEARNING FOR ARCHITECTURE: ONLINE DESIGN STUDIO AS NEW NORM FOR CRISES ADAPTATION UNDER COVID-19

mean that should facilitate the higher design courses and transfer the ideas from the abstract into reality and from knowledge to application. These studios are a tool with which students can develop their ability to analyse and think, bridge the gap between theory and practice, help to define targets for curriculum planners, and achieve sustainable personal and professional development. Therefore, for the students, the study of architecture necessitates a fundamental shift in learning mode and attitude in the transition from school. The first-year experience is of particular interest due to the challenges of adapting to a new learning environment (Kahu *et al.*, 2017), which plays a significant role in shaping students' attitudes and performance in their subsequent years (Tinto, 1993). Therefore, design students – whether they are new to the studio learning environment or have previous experience but are unsure how the design studio operates – find it very difficult to form perceptions of what occurs in the studio when instructors' personalities vary, their expectations are unclear, and the students' own backgrounds have not prepared them for this unique learning environment (Anthony, 1991; Dutton, 1987, 1991).

Generally, architecture students in their first and second years of study consider their learning experiences to be confusing and frustrating (Lueth, 2008), especially as they enter architecture school with little or no experience of design or other subjects that might contribute to their university studies. Such feelings can be traced back to students' earlier learning experiences, their lack of confidence, and the wickedness of the design process itself, or even to instructor's way of teaching. Investigations of what students know, how they think in the design studio, and what they would like to accomplish by being in a particular studio would be beneficial to their academic, social, and emotional growth and development (Alharthi *et al.*, 2019).

2.2. LEARNING INDEPENDENCE IN DESIGN STUDIOS

Due to the threat of COVID-19, all institutions of higher education in Jordan, as in many other countries, have opted to cancel all face-to-face lectures and offered emergency online teaching. Accordingly, students need to adapt to this situation and cope with a new learning identity that requires more responsibility and independence.

There has been growing concern about learning independence in the context of architecture (McClellan, 2009; Vowles *et al.*, 2012; Al Maani, 2019). These studies suggest that, to encourage independent thinking, studio instructors should be aware of their responsibility for creating an appropriate environment in which students can take the lead in controlling and developing their design learning and share responsibility (Al Maani, 2019).

Students must understand that their work should reflect deeper and higher-level processes, including processes of analysis, synthesis, and evaluation (Light *et al.*, 2009) and that it is not limited to spending time in the studio, imitating their instructor or copying others.

Learning in the design studio has various characteristics that promote learning responsibility and independence. These factors can be categorised into two groups: (a) course-related and (b) student-related. Course-related factors include (i) promoting critical, creative, and pragmatic thinking (Dutton, 1987; Koch *et al.*, 2002); (ii) developing skills that students can apply in their future courses and careers (Yanar, 1999; Koch *et al.*, 2002; Clune, 2014); and (iii) shifting the focus from teaching to learning. In addition, student-related factors include (i) communication with peers enables students to learn from working with each other and with other students of different years and levels (Lueth, 2008; McClean, 2009; Vowles *et al.*, 2012); and (ii) promoting self-confidence (Koch *et al.*, 2002).

As a result, understanding how first-year students experience design and how they progress towards independent learning in the design studio could greatly enhance the way in which they learn. As part of this process, it is also important to recognise the changes that occur in students' learning in relation to different stages of the design process.

3. Methodology

This study aimed to explore the factors that affected foundation students' perceptions and experiences related to the quality of their online design courses. The target was to gather a better idea of the types of online learning aspects that foundation architecture students valued most highly, as well as what they found challenging and why. Furthermore, it focused on learning and teaching practices, the learning quality, and the possibility of adopting virtual learning environments for future design courses. A questionnaire was used to develop a set of measures for the factors and challenges of online teaching in different programmes. A preliminary set of 32 indicators and practices was derived from the literature and grouped into two dimensions in terms of context, process, and transformation (Table 1). These factors are (a) factors related to the faculty (including instructors, feedback, access to resources, and technology measurements) and (b) factors related to learners, including individual and personal measurements (e.g., responsibility, time management, peer collaboration, learning behaviours).

TRANSFORMING LEARNING FOR ARCHITECTURE: ONLINE DESIGN STUDIO AS NEW NORM FOR CRISES ADAPTATION UNDER COVID-19

TABLE 1. Dimensions and measurements of the questionnaire: (a) factors related to faculty and (b) factors related to learners.

Sub-categories of factors	Survey measurements	
Faculty-related factors	Instructor	<ul style="list-style-type: none"> The instructor is happy/satisfied with teaching online. The workload in the online studio is the same as in the usual studio. The instructor allows the use of any available material for exercises and projects. Online communication with instructors is more efficient and comfortable than usual.
	Feedback	<ul style="list-style-type: none"> There is more feedback in the online studio than usual. Online feedback is quicker than usual. The new online grading system was explained.
	Technology	<ul style="list-style-type: none"> The student is satisfied with the application. The application runs well on the students' devices. Online communication is generally effective.
	Design process and resources	<ul style="list-style-type: none"> The online learning resources are available and helpful. The online studio is useful for conducting precedent and site analysis. The online studio is useful for developing design concepts. The online studio is useful for developing architectural drawings. The online studio is useful for conducting reviews/crits.
Students-related factors	Responsibility	<ul style="list-style-type: none"> The students are committed to attending every design studio. Access to other online design studio is easier than usual. Self-assessment of performance has been enhanced. Learning outcomes/objectives for online design course are being achieved. Students become more independent in taking decisions regarding design.
	Management	<ul style="list-style-type: none"> The online studio helps students to plan their time more effectively. The online studio leaves students with more time to study. The online tools are useful for presenting design progress, without manual drawings or physical models. The online studio has no impact on physical activity. Quarantine time has no effect on adapting the online studio.
	Peer collaboration	<ul style="list-style-type: none"> Students prefer online meetings over face-to-face alternatives. Online collaborations between peers are effective.
	Skills and behaviours	<ul style="list-style-type: none"> The online studio is a useful medium for knowledge of the course material, what is required, instructions, etc. The students' software skills have been developed. The students plan how to use paper and card in the most beneficial way (i.e., reducing their use). The students use/reuse both sides of the paper. The students reuse cards, folders, boxes, envelopes, etc.

The BSc Architecture programme in Jordan is a 5-year programme, each year having two design courses – one in each semester – in addition to other theoretical courses. In the first and second years, students are taught the knowledge, background, and practice skills for 2D and 3D design principles. The programme follows the curriculum requirements of the Accreditation and Quality Assurance Commission for Higher Education Institutions. Architecture students who took online design studios, in 15 universities in Jordan, during the lockdown (March to June 2020), were invited to complete the online questionnaire. Of the 248 students who did so, 113 were in their first year and 135 in their second, while 64.7% were attending public universities and 35.3% private institutions. The sample included 189 female students and 59 males.

Students were invited to rate the statements in the questionnaire on a five-point Likert scale, from 'strongly disagree' (1 point) to 'strongly agree' (5 points). The higher the respondent's score, the more positive their attitude towards online learning and the more positive their experience was deemed to be. Descriptive statistics were produced using SPSS and utilised to measure the students' responses.

4. Results

Overall, the data gained from the questionnaire indicate low levels of satisfaction among foundation students with the online learning experience (38.52%). The average mean for the responses related to faculty factors was 2.65, while it was slightly higher (2.92) for learner factors. The final rank order of the measurements was developed from the mean scores of the students' responses. These measures were classified into four categories in terms of their impact on the online-design-studio experience: high impact, moderate impact, low impact, and no impact (Figure 1). The barriers in the 'high impact' category had an average mean of 2.01, those in the 'moderate impact' category had an average mean of 2.39, those in the 'low impact' category had an average mean of 2.74, and the average mean of the 'no impact' factors was 3.77.

The results show that the 'high impact' barriers are mostly learner-related, as shown in Figure 1 (items 1, 3, 4; $M=1.87$). Across the whole questionnaire, the students expressed the lowest satisfaction with preferences for online meetings and online collaboration tools (8.7%). The online studio had had a negative impact on students' engagement in physical activity. A large majority (85.4%) thought that the lockdown as a whole had reduced the potential quality of the online design studio. High-impact barriers related to faculty factors (items 2, 5, 6, 7; $M=2.13$) were measured in terms of workload, feedback, and design process. Managing the workload was identified by most students (85.6%) as a particular challenge with online learning. The results indicate the importance of instructor feedback from the students' point of view. The students reported very low rates of satisfaction with the amount and frequency of feedback (14.4% and 22.4%, respectively) that they had received from their design instructors. Only 19.4% of the students found the online design studio useful for the development of concepts and architectural drawings.

The 'moderate impact' challenges were roughly equal for faculty-related measurements (items 9, 10, 11, 13, 15; $M=2.36$), and learner-related measurements (items 8, 12, 14, 16, 17; $M=2.42$). Only 16.8% of the students felt that they could clearly translate and express their design ideas when working with computers and without manual drawings or physical models.

TRANSFORMING LEARNING FOR ARCHITECTURE: ONLINE DESIGN STUDIO AS NEW NORM FOR CRISES ADAPTATION UNDER COVID-19

Categories	Measurements	Year 1 & Year 2 (N= 248)					Measurements	Year 1 & Year 2 (N= 248)				
		Strongly Disagree	Disagree	Neutral	Agree	Strongly Agree		M	S			
High Impact Average Mean = 2.01	(1) Students prefer online meeting than meeting face-to-face.	176	27	24	8	13	1.6	8.7%				
	(2) Workload in online studio is as usual studio.	149	31	32	23	13	1.9	14.4%				
	(3) Online studio has no impact on physical activity.	140	40	32	16	20	2.0	14.6%				
	(4) Quarantine time has no effect on accepting the online studio.	126	39	47	16	20	2.0	14.6%				
Moderate Impact Average Mean = 2.39	(8) Online tools are useful to express design without having manual drawings or physical models	89	63	54	23	19	2.3	16.8%				
	(9) Online communication with tutors is more efficient and comfortable than usual.	96	46	60	25	21	2.3	18.2%				
	(10) Online feedback is quicker than usual.	109	45	39	29	26	2.3	22.4%				
	(11) Online studio is useful to conduct reviews/crits.	120	37	33	18	40	2.3	23.4%				
	(12) Online collaborations between peers is effective.	94	42	58	32	22	2.4	22.0%				
	(13) The new online grading system was explained.	91	59	43	23	32	2.4	22.8%				
Low Impact Average Mean = 2.74	(14) Online studio is useful material to understand course instructions, etc.	96	41	46	33	32	2.4	25.2%				
	(15) Online studio is useful to conduct precedent and site analysis.	94	35	51	38	30	2.5	26.9%				
	(16) Online studio helps students to plan time more effectively.	87	45	58	29	29	2.5	23.8%				
	(17) Online studio offers students more time to study.	104	25	40	44	35	2.5	31.9%				
	(21) Tutor is happy/satisfied with online course.	54	52	72	44	26	2.8	29.1%				
	(22) Students become more interested in making decisions regarding design.	54	41	81	49	23	2.8	60.2%				
	(28) Tutor accepts any available material to do exercises and projects.	27	11	36	62	112	3.9	70.0%				
No Impact Average Mean = 3.77	(29) Students reuse cards, folders, boxes, envelopes, etc.	22	19	48	31	128	4.0	84.1%				
	(30) Students plan in advance how to use papers, cards in the most beneficial way (reduce).	11	15	41	57	124	4.0	89.7%				
	(31) Students commitment to attend each design studio.	16	22	33	47	130	4.1	71.8%				
	(32) Students use/reuse both sides of the paper.	12	15	37	33	131	4.3	89.4%				
	(25) Online learning resources are available and helpful.	44	57	63	46	38	3.0	59.6%				
(24) Satisfaction with the application.	43	44	53	63	45	3.1	43.5%					
(25) Self-assessment performance has enhanced.	35	17	45	73	78	3.6	28.7%					
(26) Access to other online design studio than usual	24	11	58	54	101	3.8	85.8%					
(27) Run on the application on various devices.	23	24	33	49	119	3.9	67.9%					

Ex: S: Satisfaction (percentage of positive responses of agree and strongly agree).

M: Mean

151-175 responses
126-150 responses
101-125 responses
76-100 responses
51-75 responses
26-50 responses
1-25 responses

Figure 1. Descriptive statistics for foundation students' views on various measurements of the online-design-studio experience.

In addition, 75.7% of the students reported problems with understanding the material, the requirements, and the instructions. Three-quarters (76.5%) of the students considered time to be a challenge, but this was not necessarily a *lack of time*, but rather difficulties in coping with the online environment and workload. In this study, the students' dissatisfaction with the support from their instructors was evident. Almost 81.8% of the students felt that communication with their instructor was more difficult than usual, saying they felt uncomfortable when communicating virtually. Only 22.5% of the students were happy with the new assessment criteria. Less than a quarter of the students were satisfied with reliance on online tools for conducting research and analysis and for the juries and reviews.

The following aspects were rated as low-impact or no-impact obstacles: ease of technology (e.g., internet quality, online applications), instructor flexibility in terms of permitting the use of any available materials for exercises and projects, and the availability of online resources. Although the responses in all domains were overall negative, the students did indicate that some of their learning skills had developed to a greater extent than they would have expected. Most (57%) had substantially developed their skills in various software tools (such as Photoshop, Revit, and CAD) and more than half (60.2%) believed that they had become more independent in their learning and more responsible when taking design decisions.

In addition, 71.8% students indicated that they were committed to attending every design studio. From a different perspective, this shift to online learning and greater independence has led to positive changes in terms of sustainability. Students cited changes into two areas of practice: the reduction in use and increase in reuse of materials (items 28, 29, 30, 31, 32).

5. Conclusion

Digital transformation is not a novel phenomenon, and it has been ongoing in higher education institutions for many years. The facilitation of learning – whether in the online design studio or any other learning setting – requires the formulation of inclusive pedagogic strategies that explicitly accommodate students' diversity and individuality.

In this study, many of the participants felt uncertain about aspects of design learning and wanted more guidance and support when learning online. Encouragement and direct guidance are vital during the first year, as students can feel uncertain and lost when trying to cope with learning design and this new mode of online learning. This indicates that the students are not fully aware of the scope of online learning and remain attached to the teacher-centred model. This is a predictable finding because, although the students already use technology very effectively, they are not familiar with

TRANSFORMING LEARNING FOR ARCHITECTURE: ONLINE DESIGN STUDIO AS NEW NORM FOR CRISES ADAPTATION UNDER COVID-19

the new formal digital communication tools and have not had face-to-face communication with their instructors.

The students emphasised the importance of face-to-face contact with their instructors, as this affects their understanding and learning engagement. This suggests that direct contact with students can help to ensure their different learning styles are accommodated and help the students to accomplish their learning objectives. Although the responses in all domains were overall negative, the online studio has succeeded in developing and achieving its pedagogical goals. Students are becoming more independent and taking more responsibility for their learning and design decisions at an earlier stage. They have also developed their design skills through learning and exploring design software in a short period of time. This was this primary strategy implemented to compensate for the lack of face-to-face contact with instructors. The students have also made more use of e-resources to overcome this issue.

The students also indicated that it has been beneficial for them to re-watch the recordings of the reviews and discussions in the online sessions. This highlights an important issue around feedback and assessment in both the physical and virtual design studios: during reviews, students can miss some of the feedback given to them verbally, for various reasons (including stress, the critics' behaviour, and poor communication skills). This highlights the need to have recorded and written feedback to which they can refer later. This conclusion is supported by recent studies on the same topic (Ceylan *et al.*, 2020, Alnusairat *et al.*, 2020, Al Maani, 2019), which highlight that students miss out reviews as an additional learning resource.

Peer learning is another valuable source of informal education. Beginner students experienced less communication with their peers during the online studio, which meant that they missed out on this additional learning source. Peer-to-peer communication and interaction in a group discussion are not often feasible in the online learning settings. This should be taken into consideration and reflected in the design-studio model. Design studios should be available with that type of open arrangement, and institutions should consider this necessity when developing their architecture schools. Institutions should also strive for maximum academic and social interaction between their students – and across the physical studio spaces – to enhance the students' learning experiences. Moreover, instructors should encourage their students to benefit more from technology and attend other students' reviews throughout the year, as well as arranging collaborative activities such as peer critiques and skill-sharing workshops to ensure effective high-level communication and quality learning.

A final point of interest is that the students praised the online studios for offering greater flexibility in costs and learning resources. With physical

models and drawings replaced by digital alternatives, the students have been forced to explore new design software. Online studios also offer more learning resources for students, allowing them to access a wider range of topics and information. These advantages suit the learning process of design, as students must explore new trends in architecture and remain up-to-date regarding relevant topics and projects.

All the previous issues should be considered during the development of a hyper-flexible design studio, where students have the opportunity to make direct contact with their instructors when needed and to attend online activities and reviews (the latter being highly recommended for those in the beginner years). Instructors should also be aware of the demands of workload management, implementing different approaches to teach students and not to limiting their feedback to the verbal form. The use of e-resources such as videos, articles, guest lectures, and even written feedback can enrich students' online learning and understanding of the fundamentals of design.

With the increased reliance on online learning during COVID-19, the current research is vital – not only for architecture researchers and educators, but also for the wider spectrum of educators in many programmes. However, the current study examined only the experiences of beginner students in architecture schools in Jordan with no prior practice in design or art-related subjects; and, accordingly, the generalisability of these results is subject to certain limitations.

References

- ALHARTHI, A.D., SPICHKOVA, M., AND HAMILTON, M., 2019. Sustainability requirements for eLearning systems: a systematic literature review and analysis. *Requirements engineering*, 24(4), 523-543.
- AL MAANI, D., 2019. *Exploring transition toward independent learning: student experiences in the first year of architecture school*, Doctoral dissertation, Cardiff University, UK.
- ALNUSAIRAT, S., AL MAANI, D. and AL-JOKHADAR, A., (2020), "Architecture students' satisfaction with and perceptions of online design studios during COVID-19 lockdown: the case of Jordan universities." *Archnet-IJAR: International Journal of Architectural Research*.
- ANGELOU, G.N., AND ECONOMIDES, A.A., 2007. E-learning investment risk management. *Information resources management journal*, 20(4), 80-104.
- ANTHONY, K., 1991. *Juries on trial: analysis and critique of design juries and studios*. New York: Van Nostrand Reinhold.
- ATKINSON, S.P., 2015. Adaptive learning and learning analytics: a new learning design paradigm. *BPP Working Paper*, January, 1-9.
- BROADFOOT, O., AND BENNETT, R., 2003. Design studios: online? comparing traditional face-to-face design studio education with modern internet-based design studios. *The Apple University consortium academic and developers conference: digital voyages*, 28 September - 1 October 2003, University of Adelaide, South Australia.

TRANSFORMING LEARNING FOR ARCHITECTURE: ONLINE DESIGN
STUDIO AS NEW NORM FOR CRISES ADAPTATION UNDER COVID-19

- CASANOVA, D., AND PRICE, L., 2018. Moving towards sustainable policy and practice: a five level framework for online learning sustainability. *Canadian journal of learning and technology*, 44(3), 1-20.
- CHALLIS, D., 2002. Integrating the conceptual and practice worlds: a case study from architecture. *Quality conversations: research and development in higher education*, 25, 106-113.
- CLUNE, S., 2014. Design for sustainability and the design studio. *Fusion journal*, 3.
- DUTTON, T.A., 1987. Design and studio pedagogy. *Journal of architectural education*, 41(1), 16-25.
- DUTTON, T.A., 1991. The hidden curriculum and the design studio: toward a critical studio pedagogy. *Voices in architectural education: cultural politics and pedagogy*, 165-194.
- EL-BAKRY, H.M., AND MASTORAKIS, N., 2009. E-Learning and management information systems for e-universities. *The 13th WSEAS international conference on computers*, 555-565.
- HALL, L., 2015. Building resilience for lifelong learning. *Fine print*, 38(2), 18-22.
- JATI, G., 2013. Learning management system (Moodle) and e-learning content development. *Jurnal sosioteknologi*, 12(28), 277-289.
- KAHU, E., NELSON, K., AND PICTON, C., 2017. Student interest as a key driver of engagement for first year students. *Student success*, 8(2), 55-66.
- KNOWLES, M.S., 1988. Preface. In: BOUD, D., ed. *Developing student autonomy in learning*. Routledge.
- KOCH, A., SCHWENNSSEN, K., DUTTON, T.A., AND SMITH, D., 2002. *The redesign of studio culture: A report of the AIAS studio culture task force*. American Institute of Architecture Students.
- LEDEWITZ, S., 1985. Models of design in studio teaching. *Journal of architectural education*, 38(2), 2-8.
- LIGHT, G., CALKINS, S., AND COX, R., 2009. *Learning and teaching in higher education: the reflective professional*. Sage.
- LUETH, P.L.O., 2008. *The architectural design studio as a learning environment: a qualitative exploration of architecture design student learning experiences in design studios from first-through fourth-year*. Retrospective theses and dissertations, Iowa State University.
- MCCLEAN, D., 2009. Embedding learner independence in architecture education: reconsidering design studio pedagogy.
- SALAMA, A.M., AND WILKINSON, N., eds., 2017. *Design studio pedagogy: horizons for the future*. Gateshead: The urban international press.
- SCHÖN, D.A., (1987), *Educating the reflective practitioner*.
- SCHÖN, D.A., (1985), *The design studio: An exploration of its traditions and potentials*. International Specialized Book Service Incorporated.
- SCHÖN, D. (1983). *The reflective practitioner*.
- SIMONSON, M., ZVACEK, S.M., AND SMALDINO, S., 2019. *Teaching and learning at a distance: foundations of distance education*. 7th ed. IAP.
- TINTO, V., 1993. Leaving college: rethinking the causes and cures of student attrition.
- VOWLES, H., LOW, J., AND DORON, H.R., 2012. Investigating architecture studio culture in the UK: A progress report. *Journal for education in the built environment*, 7(2), 26-49.
- WILLIAMS, A., OSTWALD, M.J., AND FULLER, S.R., 2007. Issues confronting architectural education in Australia.
- YANAR, A., 1999. *The silenced complexity of architectural design studio tradition: pedagogy, epistemology and the question of power*. Doctoral dissertation, Oxford Brookes University.

STUDENT EXPERIENCES OF ONLINE DESIGN EDUCATION POST COVID-19

A Mixed Methods Study

RAMY BAKIR, SARA ALSAADANI

*Architectural Engineering and Environmental Design Department,
Arab Academy for Science, Technology and Maritime Transport,
Cairo Campus, Elhorria Moshir Ismail St., Heliopolis, Cairo,
P.O.Box 2033*

r.bakir@aast.edu

*Architectural Engineering and Environmental Design Department,
Arab Academy for Science, Technology and Maritime Transport,
Smart Village Campus, B2401, Giza, P.O.Box 12577*

sara.alsaadani@aast.edu

AND

SHERIF ABDELMOHSEN

*Department of Architecture, American University in Cairo,
AUC Avenue, New Cairo, 11835*

sherifmorad@aucegypt.edu

Abstract. This paper presents findings of a survey conducted to assess students' experiences within the online instruction stage of their architectural education during the lockdown period caused by the COVID-19 pandemic between March and June 2020. The study was conducted in two departments of architecture in both Cairo branches of the Arab Academy for Science, Technology & Maritime Transport (AASTMT), Egypt, with special focus on courses involving a CAAD component. The objective of this exploratory study was to understand students' learning experiences within the online period, and to investigate challenges facing architectural education. A mixed methods study was used, where a questionnaire-based survey was developed to gather qualitative and quantitative data based on the opinions of a sample of students from both departments. Findings focus on the qualitative component to describe students' experiences, with quantitative data used for triangulation purposes. Results underline students' positive learning experiences and challenges faced. Insights regarding digital tool preferences were also revealed. Findings are not only significant in understanding an important event

STUDENT EXPERIENCES OF ONLINE DESIGN EDUCATION POST COVID-19: A MIXED METHODS STUDY

that caused remote architectural education in Egypt but may also serve as an important stepping-stone towards the future of design education in light of newly-introduced disruptive online learning technologies made necessary in response to lockdowns worldwide.

Keywords: *Architectural education; Online learning; Students' learning experiences; Questionnaire; Mixed methods; COVID-19.*

ملخص. تقدم هذه الورقة نتائج دراسة إستقصائية تم إجراؤه لتقييم تجارب الطلاب في مرحلة التعليم عن بعد خلال فترة الإغلاق التي سببتها جائحة الكورونا بين مارس ويونيو 2020. وقد أجريت الدراسة في قسمين للهندسة المعمارية في فرعي الأكاديمية العربية للعلوم والتكنولوجيا بالقاهرة في مصر. تم التركيز في البحث على المواد التي تتضمن مكون الـ (CAAD) والتي تعتمد على الحاسب الآلي. كان الهدف من هذه الدراسة الاستكشافية هو فهم تجارب تعلم الطلاب عبر الإنترنت خلال فترة إنتشار وباء الكورونا، وذلك لفهم التحديات التي تواجه التعليم المعماري. إستخدم البحث طريقة مختلطة لجمع البيانات، حيث تم تصميم استبيان قائم على جمع البيانات بنوعها النوعي والكمي، معتمداً على آراء عينة من الطلاب من كلا القسمين. النتائج المقدمة هنا تركز على المكون النوعي لوصف تجارب الطلاب، مع استخدام البيانات الكمية لتحقيق التعدد في أساليب جمع البيانات (Triangulation). تؤكد نتائج البحث على مجالات التحسن التي شهدتها الطلاب في تجاربهم الخاصة أثناء الإغلاق وأيضاً التحديات التي واجهوها. تم الكشف أيضاً عن نتائج تتعلق بتفضيلات الطلبة للأدوات الرقمية. تأتي أهمية النتائج في فهم وضع التعليم المعماري عن بعد في مصر، وهي أيضاً بمثابة نقطة انطلاق مهمة نحو فهم مستقبل تعليم التصميم في ضوء تقنيات التعلم الرقمي التي تم استحضارها حديثاً والتي أصبحت ضرورية للاستجابة لحالات الإغلاق في الكثير من دول العالم.

الكلمات المفتاحية: *تكنولوجيا التعليم، التعليم المعماري، التعليم عن بعد، جائحة الكورونا، دراسة استقصائية.*

1. Introduction

In March of 2020 a lockdown caused by the COVID-19 pandemic was implemented on universities in Cairo. Several architecture departments switched to online teaching within the same week and conducted distance learning until the end of that spring semester. This was enabled by developed tools that were used for course delivery, made available due to advances witnessed in online educational technologies. These support higher education and address challenges of flexibility and access (Dahlstrom et al. 2013). These tools have increasingly allowed universities worldwide to resort to online course delivery at a fraction of the cost (Drucker, 1997).

Particularly in design education, the educational community have progressively shifted attentions toward the internet, exploring potentials it offers to overcome pitfalls of traditional design studios. For example, virtual design studios (VDS), *a type of studio that investigates environments to expand studio space beyond physical and time limits,*” (Pektaş, 2015) are

widely-cited in use across schools of architecture worldwide (e.g. Kvan, 2001; Ham and Schnabel, 2011; Pektaş, 2015).

Academic Learning Management Systems (LMS) (e.g. Blackboard, Moodle, etc.) are often used to facilitate VDS setups; (Park, 2011; Lotz et al., 2015). These allow mimicking of conventional course delivery; providing students online access to course content, creating a platform for collaboration and allowing assessment of student works via a web-based environment (Kocaturk et al., 2012). Research has shown that LMS allow faculty to shift from content to process-based learning (Vogel & Klassen, 2001), while facilitating active learning (Herse & Lee, 2005). The potential of reaching students off-campus also increases student enrollment (Nunes & McPherson, 2003) and enhances faculty-student interaction (Lonn & Teasley, 2009). Moreover, reliance on LMS means that higher education institutions can control access to online course material; ensuring that only fee-paying students are allowed (Schnabel and Ham, 2014). Nevertheless, it is recognized that such virtual environments better align with instructionist teaching approaches and propagate a top-down relationship between teacher and student, while *“teaching architecture is not primarily an instructionist process, but rather a process of interaction and experience”* (Kocaturk et al., 2012). Ham (2010) posits that this leads to a culture of teaching in-silos; reducing the potential for student engagement and peer-to-peer appraisal, essential ingredients for socialization of students into the profession. *“It is no wonder why ‘distance learning’ is not a popular approach in design studio education in architecture”* (Kocaturk et al., 2012).

The new reality enforced by the COVID-19 lockdown has forced architectural educators in Egypt to come face-to-face with the developing nature of online teaching. Nearly no research exists investigating the reality of design education in times of a global pandemic. However, using the previously mentioned literature we were able to identify areas that supported this exploratory investigation into the online teaching stage of the Spring 2020 semester, focusing on understanding students’ personal experiences of learning approaches and knowledge construction (Richard, 2016). This may guide educators in the efficient set-up of online and hybrid frameworks for architectural education in the future.

2. Method

A mixed methods study was conducted, where a questionnaire-based student opinion survey was developed to gather both qualitative and quantitative data from both AASTMT architectural engineering departments in Cairo, Egypt; in Heliopolis, and at the Smart Village. The scope of this work is

STUDENT EXPERIENCES OF ONLINE DESIGN EDUCATION POST COVID-19:
A MIXED METHODS STUDY

focused on students' experiences within the design curriculum¹ that include a CAAD component. These courses include a digital or computational component in its course outline. Out of 36 core and 25 elective courses offered in the undergraduate program, 19 were selected. These were classified into two streams; the design stream that included 6 design studio courses and the Graduation Project, all of which comprised a significant digital component, including the foundational design studio due to the online stage. The second stream was for technology and computational courses, comprising 4 core courses (e.g. CAD, 3D Modeling, Environmental studies), and 8 electives (e.g. Computer Applications, Computer Graphics, etc.). These are offered between the second and final year of the 5-year BSc program.

The questionnaire comprised both closed and open-ended questions. Closed-ended questions consisted of Likert-scale statements, the purpose of which was to gauge the collective student online learning experience in terms of levels of satisfaction, effort undertaken and enjoyment. Students were also asked what physical devices and digital platforms were used to support their online learning experience. Qualitative data was collected using open-ended questions seeking to understand whether and how online learning may have enhanced students' pedagogic experience and challenges faced. Open-ended questions were also used to collect students' opinions regarding physical and digital platforms that were most and least effective, and reasons behind this.

Equal probability random sampling, which ensures that all members of the population are equally likely to be selected, was used to construct a sample of students from both AASTMT campuses, to distribute the questionnaire to. A total of 502 students were registered in the afore-named courses in Heliopolis campus, and 215 students were registered in these courses at Smart Village, comprising a population of 717 students. A sample size was calculated for each campus according to the population of registered students using the equations 1 and 2 (Czaja and Blair 1996). The first equation is for large populations of several thousand; and does not take the original population size into account. Therefore, the correction factor for finite populations (equation 2) (Czaja and Blair, 1996) was used.

$$\text{Sample size} = \frac{Z^2 \times p \times (1 - p)}{m^2}$$

Such that:

Z = the confidence level. 95% confidence level means Z = 1.96

p = worst case percentage, expressed as a decimal. Conservative value = 0.5.

m = margin of error, expressed as a decimal. 95% confidence level means m = 0.05.

¹ Both branches offer the same architectural engineering curriculum.

(1)

Based on these equations, and for a confidence level of 95%, the sample needed that would be representative of the total population was 218 students from Heliopolis branch, and 138 from Smart Village (356 students in total ($n=356$)). In equal probability systematic sampling, a sampling interval is needed to systematically select members of the sample from the population; and to ensure that each member of the sample has an equal chance of being sampled. According to equation 3 (Czaja and Blair, 1996), which was used to determine interval size, an interval of 2 was used to derive the sample of 356 students from the total population of 717 students. A starting point was chosen at the first student in the compiled list of registered students. Sampled students received links of the questionnaire created. By the time this paper was prepared 162 students had participated in the online survey hosted on Google forms, with a response rate of 45.5%. Students' fully-informed consent was obtained prior to responding to the questionnaires, and all questionnaires were collected completely anonymously.

$$\text{New sample size} = \frac{\text{sample size}}{[(\text{sample size}-1)/\text{population}]+1} \quad (2)$$

Such that:

$$\text{Interval size} = \frac{N}{n}$$

N = Total population
n = Sample size (calculated from equations 1 and 2)

(3)

Qualitative responses to open-ended questions were coded using thematic content analysis, to extrapolate and identify reasons for positive experiences and challenges faced by the students to the online process. Quantitative data was initially coded onto a Microsoft Excel spreadsheet, which was then imported into the statistical software package SPSS for descriptive statistical analyses. Components of both quantitative and qualitative findings are reported in the results section of this paper. Nevertheless, as there is little work on design education during conditions of a global pandemic, in this contribution, we use students' qualitative opinions and statements as a starting point to collate and understand their opinions of online learning. Thus, in the upcoming results section, most findings presented are qualitative in nature, whereas descriptive statistics are used for purposes of triangulation, generating complementarity, and where applicable, understanding whether the qualitatively-voiced opinions were similarly shared by the wider sample of students.

STUDENT EXPERIENCES OF ONLINE DESIGN EDUCATION POST COVID-19:
A MIXED METHODS STUDY

3. Results and Analysis

The 162 responding sample students represented the 4 years studied nearly equally. Females constituted nearly 60% of the sample. Students with a GPA of more than 2.80 constituted 72.8% of the responding students, and nearly 61% of them were registered in 6 courses during the studied semester.

3.1. STUDENT EXPERIENCES

Students were asked to compare their overall experience during the studied semester compared to previous semesters. In general students appeared to appreciate the online stage, as 47.6% of 162 students perceived the experience positively, while only 28% reported finding the experience either fair or poor (Table 1). In table 1 also, student experiences are further broken down in terms of, effort and level of satisfaction; generally reported to lie on either the positive end of the weighting scales, or average. Further data analysis of the open-ended questions presents a more in-depth understanding of such experience, with students describing what they **perceived as positive experiences of online instruction, and/or how it enhanced their learning.**

TABLE 1. Statistical analysis of student experience

OVERALL EXPERIENCE		IN TERMS OF THE EFFORT		IN TERMS OF LEVEL OF SATISFACTION.	
16.3%	Excellent	4.4%	Not demanding at all	11.9%	Extremely rewarding
31.3%	Good	16.4%	Not demanding	22.5%	Rewarding
24.4%	Average	35.8%	Average	42.5%	Average
15.0%	Fair	30.2%	Demanding	15.6%	Unrewarding
13.0%	Poor	13.2%	Extremely demanding	7.5%	Extremely unrewarding

3.1.1. Positive Experiences

Both quantitative and qualitative data indicated that students generally enjoyed the online learning instruction phase. Based on quantitative results, 45% of the sample enjoyed or extremely enjoyed the online design studio phase, compared to 28.4% of the sample who did not enjoy it. Analysis of qualitative data further indicated 4 main themes, and 8 sub-themes that capture reasons for students' appreciation of online instruction, and how it enhanced their learning (figure 1).

Overwhelmingly students mentioned the aspect of **saved time** as the most important aspect of their appreciation of the online stage; time saved on

commute and printing allowed students to invest more time to “*accomplish more*” in their studies with “*full concentration*.” Three students indicated that the online stage was more **focused** mainly because they were able to work “*without the regular distractions in design studios*.”

Students reported **increased support from faculty members** during the online stage, who were “*very friendly and helpful*,” and “*were giving every single effort they could do to help*.” Furthermore, **enhanced quality of feedback** given by instructors, which was described as “*to the point and very organized*” meant that students felt encouraged and supported. These insights are supported by quantitatively data; as 52% of students reported receiving beneficial or highly-beneficial feedback from their instructors, compared to 29% of the sample who rated the feedback received from instructors as average. Similarly, 49% of respondents rated feedback received from TAs to be either beneficial or highly-beneficial. Possibly as a consequence, the online stage was reported as **less stressful**; as evident in responses such as; “*it was easy and organized. I didn’t feel pressured like back at college*.”

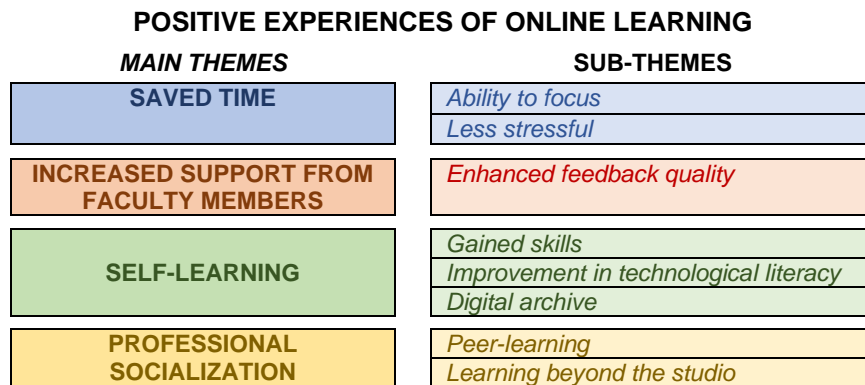

Figure 1. Main themes and sub-themes describing students’ positive experiences of online learning.

Self-learning was cited as a benefit of online learning, which “*help[ed] [them] in becoming more independent*,” and “*made [them] search more by [themselves]*.” Students also appreciated additionally **gained skills** obtained through self-learning, which enabled them to share and present their work, as is evident in responses such as; “*allowed more time for searching*,” and “*enhanced ... presentation skills*.” One of the skills particularly noted was **improvements in technological literacy**, as students “*learned more about technology, and new programs*,” and “*sketch on their work on the screen*.” Having a **digital archive** was also cited as a positive attribute of online learning, as “*recorded lectures could easily be referred back to in time of need*,” allowing them to “*listen carefully to the things*”

STUDENT EXPERIENCES OF ONLINE DESIGN EDUCATION POST COVID-19:
A MIXED METHODS STUDY

[they] want to change in [their] project” after their recorded feedback sessions.

Alluding to **professional socialization**, five students indicated that **peer-learning** was enhanced in the online stage, as by “listening to different ideas and as students we were helping each other with some information, [which] was inspiring and helpful for the projects.” One student even expressed that his/her **learning** has reached even **beyond the studio**, by gaining access to “new platforms allowing the idea of easily communicating and working internationally in architecture” learning from the many free to access streams and discussion that were made available online. Despite this, results from the quantitative component of the study indicate that 44% of students report finding the online design studio experience to be completely or somewhat isolating.

3.1.2. Perceived Challenges

Only 108 respondents replied to the question asking them to “describe any difficulties/challenges they faced during online instruction.” Qualitative responses were coded to reveal 3 main themes and 8 sub-themes capturing challenges that students faced (figure 2).

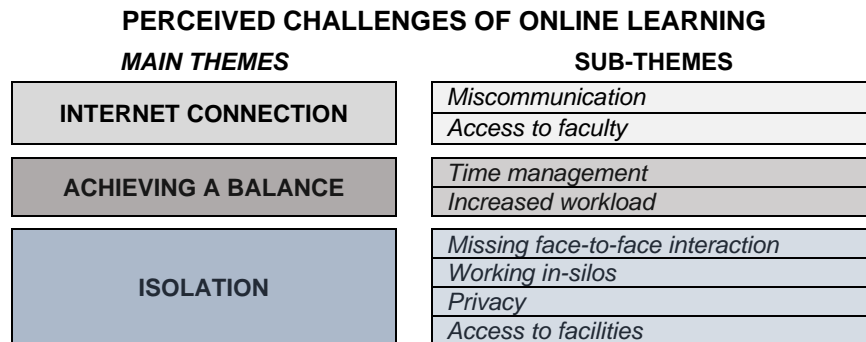

Figure 2. Main themes and sub-themes describing students’ perceived challenges during online learning.

The most two most overwhelming challenges were that of **internet connection** and **miscommunication**. The poor internet connection did not only make them “miss a few sessions” or “parts of the lecture,” but also one student cited internet cost as a challenge, as the “budget of internet payment was too much.” It also emerged that the new online terrain was unfamiliar to most parties involved during the initial stages of transition to online teaching, leading to potential miscommunications. Students cited that “it was extremely difficult to communicate with the tutors” and that “some doctors found it hard to give proper feedback online.” In addition, **access to faculty** was another challenge frequently mentioned by students; who stated

that *“it was very difficult to be in touch with some of the staff,”* and that *“some of TAs weren’t available for the office hours.”* Nevertheless, most students indicated that these types of challenges had been *“ironed out by the finals.”*

Increased workload is another frequently-cited challenge, where some students mentioned they were getting *“more assignments which puts [them] under pressure and leads to incomplete research or assignments,”* which in turn *“increases the stress on the students by the several deadlines that follow.”* Despite the earlier-cited result of saved time on commute and/or printing, students indicated that difficulties in **time management** was an issue, as *“meetings with doctors end after hours of the time of the lecture,”* Another student mentioned that *“a lot of submissions had little time to complete”* and another complained from *“taking the lectures during a different time than those shown in the schedule.”*

Missing **face-to-face interaction** was cited as a challenge; evident in statements such as *“showing work was harder online than face-to-face”* as students felt that they were not *“able to express the thoughts/ ideas as easily as in person.”* As a consequence, some students felt that they were losing the *“spirit of challenge”* that exists in physical design studios. A difficulty was also expressed at working in **separate silos**; *“not seeing others’ feedback or panels made us completely blind on which stage are we in exactly”*.

This is supported by results from the quantitative dataset, as 44% of students agreed that they found the online learning experience either completely or somewhat isolating. Nevertheless, despite such descriptions of isolation, students also indicating having issues with **privacy**, as *“all [virtual] platforms are reachable even WhatsApp, as a student it’s very overwhelming.”* Both qualitative and quantitative data indicates that students *“didn’t like to switch on [their] camera in [their] home;”* almost 40% of respondents state that they rarely switched on their camera and 13.7% never switched the camera on.

One theme that appeared to be distinct to the technology/computational stream arose regarding **access to facilities**, as students indicated that their courses required demanding software and use of the department’s computers. Not being on-campus meant that they *“use[d] [their] own laptops which wasn’t able to handle the rendering.”* Nevertheless, as multiple student responses were related to the use of different educational technologies, we further explore students’ experiences with such devices and online platforms in the forthcoming sections.

STUDENT EXPERIENCES OF ONLINE DESIGN EDUCATION POST COVID-19:
A MIXED METHODS STUDY

3.2. STUDENT PREFERENCES OF ONLINE PLATFORMS

According to the descriptive statistics shown in figure 3, students reported using up to 6 online platforms simultaneously, to continue their online courses throughout the lockdown period. Almost 27% of students report using 3 online platforms in a single course during the online semester, while less than 7% of students report using 6 platforms per course.

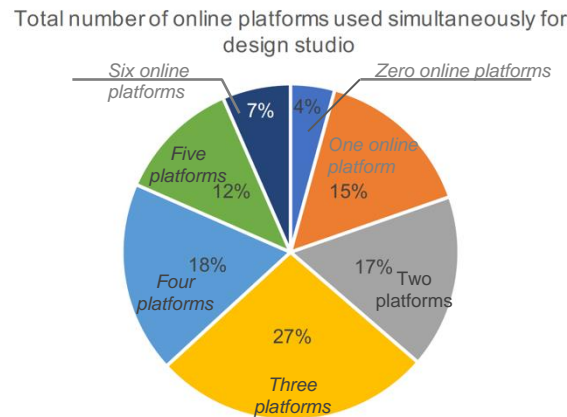

Figure 3. Total number of online platforms used.

The most and least efficient of these platforms, as experienced and reported by students in their questionnaire responses, are shown in figure 4. The overwhelming majority of students (over 79%) consider Zoom to be the most efficient platform, and almost 50% of students found the private university network least efficient of all platforms.

EFFICIENCY OF ONLINE PLATFORMS USED

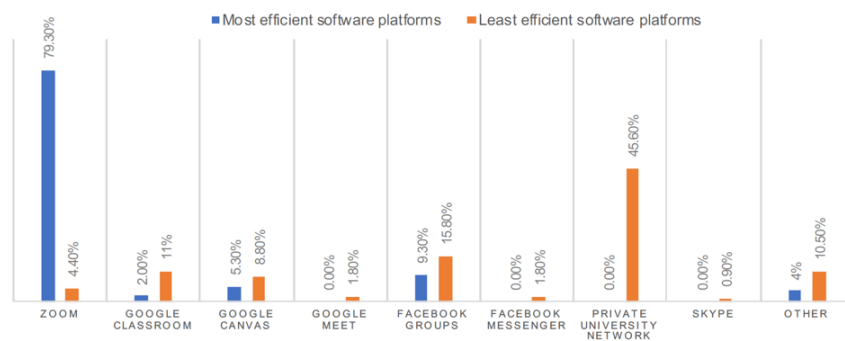

Figure 4. Most-efficient and least-efficient software platforms, as perceived by students.

3.2.1. Most Preferred Platforms

Thematic analysis of qualitatively-collected responses revealed 102 instances in which Zoom was cited as the most efficient platform, followed by Facebook groups; which agrees with quantitative responses.

Students found Zoom suitable for long lectures, feedback sessions for online design studios as well as quick 5-minute calls. Preference for Zoom included that it was efficient for receiving feedback and sketches, screen-sharing, user-friendliness, live-stream 2-way real-time communication, quick setup and access of sessions, remote control of screen, organization via breakrooms, and saving screenshots. For most students it was *“easy, clear and versatile to use, with its annotating functions being key in online feedback”* and *“it provided a better and closer experience to a real live one.”* Generally, students underlined that the platform provided *“tools that somehow replace the physical ones.”* Preference was also drawn from the notion that the conversation could be controlled both by the student and/or the instructor, and that feedback sessions could be established via voice and video *“if needed and approved by both parties.”*

Nevertheless, use of the Zoom platform was mostly reported in conjunction with other applications, including Facebook Groups, Google Classroom, Google Canvas, Schoology and What’s App to name a few. These combinations appear to be preferred for providing an easy and organized experience for communication feedback and submission.

Both qualitative and quantitative data (figure 4) indicate that students found **Facebook groups** to be the most efficient platform, subsequent to Zoom. This efficiency was related to the instructors used it for public announcements that students quickly and easily received notifications for. Also many students mentioned that, by sharing their work within a private group, it allowed them to see the work of their peers, and the feedback they received, helping them to their work progress and development compared to their peers. Students also mentioned how *“it’s easy to control Facebook notifications and what you want to be notified of.”* Being a well-established platform that most students already used made several consider it efficient due to its reliability and how it never lagged. Having the work kept on the group ‘wall’ helped them *“get inspired by one another...[and] it was beneficial as we were able to have even the slightest feedback in a shape of a comment on each photo shared,”* which helped them *“get inspired by one another’s work.”*

3.2.2. Least Preferred Platforms

Again, both qualitative and quantitative results to the questionnaire (table 3) indicate that the **private university online platform** was generally least preferred by most of the students. While one student appreciated how it was dependable *“for submitting and downloading course material, its potential*

STUDENT EXPERIENCES OF ONLINE DESIGN EDUCATION POST COVID-19: A MIXED METHODS STUDY

as a comprehensive study platform with built-in communication systems was wasted.” The interface was perceived as complicated and *“harder to maneuver and was constantly down with very limited capacity to upload submissions.”* The issue of limitation on number and size of files to upload appeared to have forced most students to decrease the quality of their submissions or reduce file size. The issue of it lagging or being down due high number of submissions led to problems in exam and final submissions times. Nevertheless, several students however mentioned how it developed throughout the 2 months period of the online stage. The fact that it does not present 2-way communication (live streaming), and that students did not receive *“notifications for any announcement, and [they] had to check [them]selves”* repeatedly for assignments and announcements also appeared problematic.

While **Facebook groups** were considered one of the most efficient platforms for communication and announcements as described in section 3.3.1, other students described it as least efficient and felt that the tool is not suitable for teaching purposes, or receiving direct design feedback. The **Facebook Live** feature, which allows the instructor to broadcast a live video/audio was also considered one of the least preferable platforms because *“the only way [the students] communicated with the lecturer was by writing comments, which is not very efficient and due to connection lags, misunderstandings always occurred.”* Students expressed that, while they had occasionally communicated with their instructors via the instant messaging facility offered by Facebook before the lockdown period, relying on instant messaging for communication without face-to-face *meetings “was hard, and [messenger] was only [useful] for short notes or questions or quick updates.”*

Despite being considered the most efficient platform by almost 80% of students as indicated in table 3; one reason that **Zoom** was sometimes cited as non-efficient was for the 45-minute limit for a session for basic accounts that some instructors were limited to.

4. Conclusion

This exploratory work seeks to understand students’ perceptions of online learning experiences. A mixed methods approach is used, comprised of a questionnaire-based student opinion survey which was developed to gather both quantitative and qualitative data from two AASTMT architectural engineering departments in Cairo; in Heliopolis, and Smart Village. The questionnaire focused on design, technology, and elective undergraduate courses that had a CAAD component in the curriculum. At the time of writing, 162 students had participated in the online survey, after which

analyses were conducted to gauge student experiences of online learning during the 2020 lockdown period 2020, and understand positive experiences, perceived challenges, tool preferences and reasons behind.

Despite the sudden onset of the lockdown experienced and transition to online learning with no prior preparation, the dataset shows that, in general, sampled students had a positive experience of online learning. Data analysis of open-ended questions four main themes identifying how the students perceived the ways by which online learning enhanced their learning (saved time – increased support from faculty members – self-learning and professional socialization) and eight sub-themes. The main challenges pertained to internet connectivity issues, access to facilities, sense of isolation and achieving a balance between available time and the increased workload experienced. Nevertheless, these challenges may be considered as opportunities for development in the future of design learning, in light future design education during the COVID-19 reality.

Positive and negative experiences described may have been influenced by use of online teaching platforms. Despite how the departments rapidly faced the new demanding reality of online technology tools, again positive aspects were identified, as the overwhelming majority of students found Zoom to be the most efficient platform used. Reasons appear to be related to qualities that the platforms provide, including live communication –digital archiving – control and privacy and notifications, to name a few. Nevertheless, it is worth noting that when platforms, such as Zoom and Facebook Messenger, were both described as both most and least efficient, this was related to the contexts and ways in which these are used.

This mixed-methods exploration provides a preliminary understanding of students' experiences with online learning in design education; an important first step as we navigate the complex and arduous post-pandemic reality, which has had an intrinsic impact on architectural education. The findings have notable implications for educators in the field who seek to maintain adequate levels of student understanding and engagement in this new pedagogic landscape, while keeping abreast of the challenges imposed. By better understanding students' experiences and usage of online technology we could better shape frameworks for online/hybrid design education in this post COVID-19 reality.

Having painted a picture of student experiences, we further seek to extend this work by digging deeper into the quantitative dataset during the next stage of the research, to decipher statistically-ascertained patterns between variables. This may allow us to visualize how experiences may vary for academic cohorts from different year groups, and accordingly allow us to address student needs in a more constructive and tailored manner. This detailed understanding may open various avenues for further investigation, to answer research questions pertaining to whether and how students' design-thinking is possibly transformed in online design teaching settings,

STUDENT EXPERIENCES OF ONLINE DESIGN EDUCATION POST COVID-19: A MIXED METHODS STUDY

allowing us to understand the implications of rapid online communication technology developments on the design process in future work.

5. References

- CZAJA and BLAIR 1996. *Designing surveys; A guide to decisions and procedures*. London: Sage.
- DAHLSTROM, E., WALKER, J. and DZUIBAN, C. 2013. ECAR study of undergraduate students and information technology, 2013. Louisville: Educause. Retrieved from <http://www.educause.edu/ecar>.
- DRUCKER, P. 1997. Universities won't survive, *Forbes Magazine*, <https://www.forbes.com/forbes/1997/0310/5905122a.html?sh=2bfdd1e424b9>
- HAM, J., and SCHNABEL M. A. 2011. Web 2.0 virtual design studio: Social networking as facilitator of design education. *Architectural Science Review* 54, no 2: 109-116.
- HAM, J. J. 2010. Working outside of the system: engaging in Web 2.0 to enhance learning and teaching in the design studio. *Proceedings of the 15th International Conference on Computer-Aided Architectural Design Research in Asia CAADRIA*, CAADRIA, Hong Kong.
- HERSE, P., and LEE, A. 2005. Optometry and WebCT: A student survey of the value of web-based learning environments in optometric education. *Clinical and Experimental Optometry* 88, no. 1: 46-52.
- KOCATURK, T, BALBO, R., MEDJDOUB, B. AND VELIZ, A. 2012. An innovative approach to technology mediated architectural design education; A framework for a web-based socio-cognitive ecosystem, *Proceedings of the 30th eCAADe Conference*, Prague, Czech Republic.
- KVAN, T. 2001. The pedagogy of virtual design studios. *Automation in Construction* 10, no. 2001: 345-353.
- LONN, S., and TEASLEY, S. 2009. Saving time or innovating practice: Investigating perceptions and uses of Learning Management Systems. *Computers & Education* 53, no. 3: 686-694.
- LOTZ, N., HOLDEN, G. and JONES, D. 2015. Social engagement in online design pedagogies, *Proceedings of Learn X Design; The 3rd International Conference for Design Education Researchers*, Chicago, Illinois, USA.
- NUNES, M. B. and MCPHERSON, M. 2003. Action research in continuing professional distance education. *Journal of Computer Assisted Learning*, 19, no. 4: 429-437.
- PARK, L. Y. 2011. Design education online: Learning delivery and evaluation. *International Journal of Art and Design Education*, 30 no. 2: 176-187.
- PEKTAS, S. T. 2015. The virtual design studio on the cloud: A blended and distributed approach for technology-mediated design education. *Architectural Science Review*, 58 no. 3: 255-265.
- RICHARD, T. 2016. *Collaboration and Student Engagement in Design Education*. IGI Global.
- SCHNABEL, M. A. and HAM, J. J. 2014. The social network learning cloud: Architectural education for the 21st Century. *International Journal of Architectural Computing*, 12 no. 3: 225-241.
- VOGEL, D. and KLASSEN, J. 2001. Technology-supported learning: status, issues and trends. *Journal of Computer Assisted Learning*, 17, no. 2: 104-114.

PARAMETRIC TOOL TO SKETCH SONIC AMBIENCES

Esquissons, a plugin for ecological and educational issues

THEO MARCHAL, NOHA GAMAL SAID

Equipe Cresson: Centre de recherche sur l'espace sonore et l'environnement urbain – Lab. AAU “Ambiances – Architectures, Urbanités” - Ecole Nationale Supérieure d'Architecture de Grenoble.

Email address: theo.marchal@grenoble.archi.fr

Ain Shams University, Faculty of Engineering, Department of Architecture and Urban Design.

Equipe Cresson: Centre de recherche sur l'espace sonore et l'environnement urbain – Lab. AAU “Ambiances – Architectures, Urbanités” - Ecole Nationale Supérieure d'Architecture de Grenoble.

Email address:

noha.gamalsaid@eng.asu.edu.eg, said.n@grenoble.archi.fr

Abstract. This paper presents the process and outcomes of a thematic winter school on designing sustainable soundscapes. It aims to present a new parametric tool: Esquis'Sons! that has been initiated during a French research project on sustainable sound environment and then developed as part of Theo Marchal's PhD. Combining Rhinoceros and Grasshopper, the Esquis'Sons! tool has allowed the integration of the sound dimension during the design phase of architectural spaces. The thematic school aims to test the validity of this tool through experimenting it with multidisciplinary teams involving architecture, urban design, acoustics, art, landscape and sociology. We have chosen to use this methodology on two urban districts located in Grenoble, France in order to auralize in real time the different intervention scenarios proposed by participants for ameliorating the experience of sound in the two districts.

ملخص. تشارك الورقة البحثية مسار ومخرجات العملية التعليمية لورشة عمل حول تصميم الفراغات الصوتية المستدامة. وتهدف إلى تقييم أداة برمجية بارامترية plug-in تحت مسمى Esquis'Son! تم برمجتها خلال مشروع بحثي فرنسي وتم إستخدامها في رسالة الدكتوراه الخاصة بماتيو مارشال بكلية العمارة بجرنوبل. الأداة البرمجية تعمل مع برنامجي رينوسيروس وجراسهوبر بحيث تم إدماج البعد الصوتي في المرحلة التصميمية للفراغات المعمارية والعمرانية. في هذا الإطار كان الهدف الرئيسي من ورشة العمل هو

PARAMETRIC TOOL TO SKETCH SONIC AMBIENCES

إختبار مدى كفاءه هذه الأداة البارامترية وذلك من خلال دراسة تطبيقية علي أحياء عمرانية بمدينة جرونوبل قام بها فريق عمل من مختلف التخصصات والتي تشمل العمارة وال عمران والصوتيات وتنسيق الموقع وعلم الإجتماع. كان الهدف من ورشة العمل هو دراسة التغير في الأصوات العمرانية عند إقتراح تغيير في الشكل العمراني والمعماري للمكان والذي يقترحه المشتركين في ورشة العمل من أجل تحسين الخبرة الحسية الصوتية في الأحياء العمرانية تحت الدراسة.

1. Esquis'Sons! Design support tools for sustainable sound environments

Esquis'Sons! is a parametric tool that constitutes the main focus of this paper. Its name couples two French terms: *esquisse* and *son*. *Esquisse* in French is equivalent to “Sketch” in English; it signifies an architectural tool for elaborating the main design concept and corresponds to the early design phase as well; while *son* means sounds. This combination ‘*Esquis'Sons!*’ highlights the objective behind the creation of this tool, which involves primarily introducing the sound dimension as a main design material to be manipulated in the early stages of the design process.

Esquis'Sons! is therefore a sound sketch tool built as a parametric interface using the Grasshopper plug-in in order to link Rhinoceros (3D modeling) and Max MSP (3D sound creation). The tool allows for the possibility to hear sound scenes generated from a digital model of space in 3D. It also allows for assigning acoustic characteristics, such as the level of porosity of volumes and faces, to spatial contexts, in addition to positioning points of listening anywhere in the 3D modeled space. The auralization module is informed by the geometrical characteristics of the spatial model and vice versa. We then adjust the qualities and the origin of the sound environments of the scene (Rémy, et al. 2016).

It is worth mentioning that Esquis'Sons's idea was initiated during a French research project dealing with sustainable soundscapes that took place in 2014 and 2015 and was funded by ADEME (*Agence de l'environnement et de la maîtrise de l'énergie*). The project, that was proposed by Equipe Cresson – Grenoble School of Architecture, is entitled “*Esquis'Sons!* Sustainable soundscape help tools”. It was conducted by a multidisciplinary research team including architects, urban designers, acousticians, and sound technicians.

2. Thematic School on Sketching Sonic Ambiences: Towers and Courtyards in Dense Urban Contexts

After a first impulse, the tool as a search result allowed to sketch the sound environments on the balcony. It was then developed to reach a sound sketch

tool status applicable in any urban context (Marchal, 2015). The next step was to test the validity of the Esquis'Sons tool in an educational exercise. We have chosen the form of an intensive one-week thematic school on soundscapes that took place in Grenoble in January 2017 during the week of sound- A European event on Sounds. Managed by the Cresson research team at the Grenoble School of Architecture, the objective of this thematic winter school was to introduce the sound dimension in contemporary architectural issues by coupling work on sound environments and dense urban forms. Sound, which is today an important element to enhance the quality of life of the built space, is particularly important in the increasingly dense urban environment.

In fact, dense urban forms propose a specific architectural language in which aspects such as building heights, shared spaces or more generally the question of interfaces play an important role in constituting ordinary listening and changing sound practices. Providing a dynamic relation to the surrounding, varying from ground to sky, from near to far or from intimacy to exposure, the dense habitat brings out remarkable listening situations, including suspension, immersion, nesting, panoramic sound, dual listening, exposure, or acoustic retreat (Gamal Said, Marchal, 2017).

Based on a space-sound pairing concept, the winter school focused on two archetypal dense urban forms: towers and courtyards, therefore defining a language of protrusions and voids (Figure 1). In this urban configuration, the interfaces located at the articulation between private and public spaces, such as balconies, loggias, corridors and landings, form shared sound spaces, which constitute in this winter school the main architectural object of study. They are as much configured by the sound qualities of the street as they themselves configure the sound qualities of the latter. It is in this reciprocal exchange that we shall consider these liminal spaces, in the way that they redraw new acoustic arenas and negotiate their intimacy with public spaces. In dialogue with the existing environment, we sketch sound atmospheres based on the Esquis'Sons tool.

In order to auralize in real time the different audio-spatial intervention scenarios, participants engaged in *in situ* sound recordings, representations, manipulations and sketches, where the intention was to explore sounds in order to create an atmosphere (Figure 2).

Participants of the winter school were invited to pursue the following steps: The first step is to define a spatial context, which was to be modeled in Rhinoceros3D via Grasshopper. The second step is to set listening points by associating a point in the model with the position of the listening point from which auralization is to be calculated in real-time. In the third step, they build a sound scene by defining sources associated with points « source_location » in the Rhinoceros / Grasshopper 3D model. The last step involves auralization in real-time by connecting these different objects to the

PARAMETRIC TOOL TO SKETCH SONIC AMBIENCES

main sketch motor through which we obtain a sound result (Remy, *et al.* 2016).

3. Sound Diagnosis in Two Urban Districts in Grenoble

Two districts in Grenoble, France, Village Olympique and Vigny Musset were chosen as case studies for conducting the sound diagnosis and modification (Figure 03). The urban configurations of the two districts are composed of pedestrian spaces which are qualified in terms of sound as impermeable in certain spaces and porous in others due to the presence of *sound doors* opening to the outside, or completely open, exposed to urban traffic.

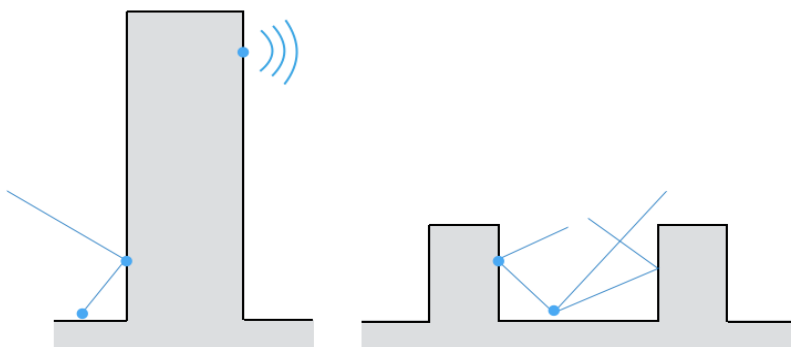

Figure. 1. The two urban fabrics: courtyards and towers and their acoustic behavior

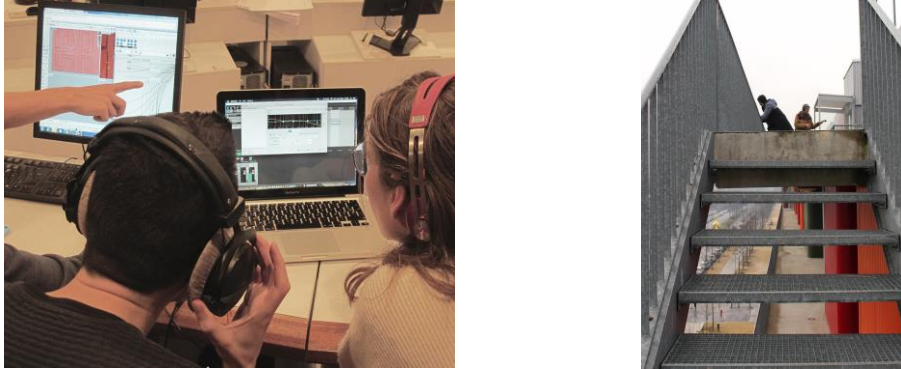

Figure 2. The in-situ sound recordings and the studios for elaborating the sound scenarios

Despite the contrast in urban and architectural forms of the two districts, their geographical juxtaposition has allowed participants to compare and articulate them by means of transversal listening. Two sound walks were conducted, one was free and silent during the day and the other was nocturnal and guided by Pascal Amphoux. These listening exercises have allowed participants to identify certain sono-architectural typologies and to distinguish the sound markers and the singularity of the soundscapes of both districts. Beyond a simple diagnosis, the main objective of this phase is to spot specific characteristics in order to steer prospective transformation.



Figure 3. The urban form of Vigny-Musset to left composed of courtyards and Village Olympic to the right composed of linear pedestrian streets with residential towers.

4. Sound Intervention Scenarios using Esquis'sons tool

The main objective of the thematic winter school is to use the Esquis'sons tool to design and project new sound environments for both districts. In

PARAMETRIC TOOL TO SKETCH SONIC AMBIENCES

order to attain this goal, participants manipulated different scales to change the existing soundscape: the urban neighborhood, the architectural buildings and courtyards, until reaching architectural elements at the body scale (*dispositifs architecturaux*). The proposed interventions focused on the notions of height, porosity, and temporality as main features of a dense sound configuration.

Several categories of sound intervention scenarios were identified. Some propose important spatial modifications in order to change their sound perception, such as “Variations in suspension”. Others propose an implantation of new sound sources or a displacement of the existing ones in order to modify the soundscape itself and to offer new listening experiences such as sonic markers (*Amers Sonores*) or “From the fountain to the market”. Finally, certain scenarios target the quality of the sound spaces themselves through modifying their uses, such as the example of “Degrees of publicity”. Six sound intervention scenarios were proposed in this workshop:

4.1. DEGREES OF PUBLICITY, *DEGRÉE DE PUBLICITÉ*

Scale of intervention: the courtyard as an urban element

The main idea of this project is to remove or open the gates and the grid surrounding the courtyard. This simple intervention changes the status of the courtyard as a private entity to a public space. This modification helps accommodating other usage patterns such as traversing, encounters, etc. The sonic sketch helped incorporating by sounds the increase in the degree of permeability between the interior ambience of the courtyard and the outer one of the street. The soundtrack permits to better understand the transformation in the sound environment of the courtyard (Figure 4).

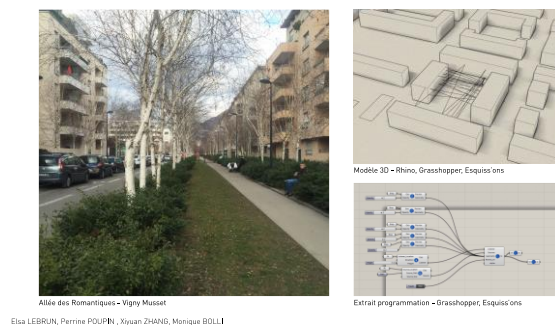

Figure 4. The location of the intervention scenario in Vigny-Musset with a Rhino and Grasshopper sketch.

4.2 THE FLYING BENCH, *LE BANC VOLANT*

Scale of intervention: the tower as building

The main idea is to work the relationship between building heights as a main characteristic of the dense urban form and sound perception. By modifying the presence of a sound source (a ball game), the Esquis'sons tool enabled a continuous reconfiguration of the listening experience as one climbs the stairs of a tower located in the Olympic Village. The building height underlines the change in sound perception through alternating between near and faraway sounds.

4.3 InTERREaction

Scale of intervention: the street and the courtyard

This project proposes a sound perspective for the pedestrian alley “Allée des Romantiques” -mainly in front of Marie Reynoard School in Vigny-Musset. It is a green linear space or promenade traversing the district and delimits enclosed spaces (courtyard and school). The proposed sound sketch seeks to make the urban configuration more porous, create spaces for sociability, and make the school entrance more secure by prohibiting vehicular passage. Participants propose rural imprints by transforming certain green spaces into community gardens. The change in land covering (gravel and soil) creates a sonorous ground that marks the thresholds between public and private space (Figure 5).

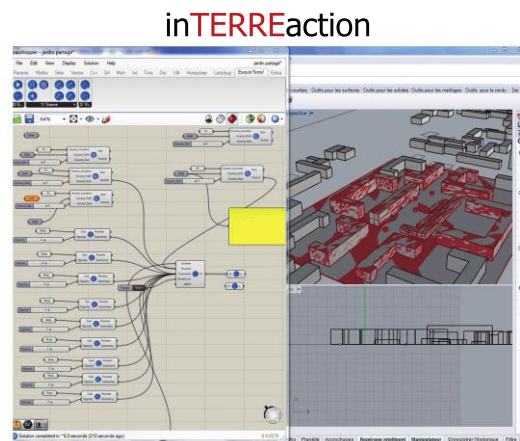

Figure 5. The location of the intervention scenario of InTERREaction in Vigny-Musset with a Rhino and Grasshopper sketch.

4.4 **Sonic markers, *Amers Sonores***

Scale of intervention: the district

The project seeks to characterize certain places from a sound point of view by creating sound markers. In fact, the Esquis'sons! tool allows to insert different sound sources and to vary their size. The injection of the sonic markers brings an entirely new dimension of a more or less distant listening to the neighborhood. Facing the homogenization of the sound space of Vigny-Musset, the proposed sonic sketch helps adding some relief to the sonic experience.

4.5 **Variations in suspension, *Variations en suspension***

Scale of intervention: the district

The sound-walk along the two districts - Vigny Musset and the Olympic Village –led the group to compare the two sound environments. The objective of this project is to import the different sono-spatial typologies composing the soundscape of the Olympic Village (pedestrian bridges, heights of the towers, and sound door) into the district of Vigny-Musset. In this optic, the team proposes a traversing sonorous bridge. The chosen path for this bridge flies over different urban elements such as the courtyard, street, pedestrian street, and main garden, giving rise to a new listening experience. The sonic sketch offers new porosities between private and public spaces: the street, school yard, buildings, courtyards, gardens and avenues. The variation in height along the bridge provides a more distant perception of the district's soundscape.

4.6 **From the fountain to the market, *De la fontaine au marché***

Scale of intervention: the neighborhood

This project is about designing a new soundwalk that is available to hear on smart phones. After capturing the existing different sounds along the chosen path, the team develops a more exotic soundscape of Vigny-Musset! In the gridiron pattern of Vigny-Musset, the group wants to create sonic poles. It proposes to insert charismatic sources and to polarize public life in order to give back to the courtyards their main role as spaces of intimacy. A market,

a fountain, a tropical greenhouse or a zoo, are examples. You are all invited to log in to hear the sounds of tomorrow!

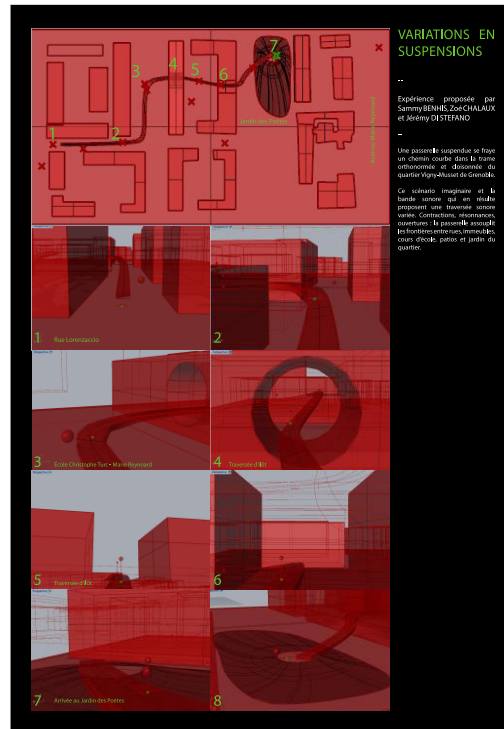

Figure 6. A sketch of Variation in suspension in Vigny-Musset using Rhino and Grasshopper

5. Conclusion

The Esquis'Sons tool has allowed participants to propose real sound projects that constitute a solid material to listen and to debate. Thanks to this tool, it is possible to « sonorize » a 3D virtual environment and then to hear the consequences of architectural choices. In other words, this application allows you to sketch a space while listening to it.

The projection of new sound scenarios results from combining the use of digital design tools (Rhinoceros / Grasshopper / Esquis'Sons!) with fieldwork by means of in situ sound recording and brief interviews with the inhabitants. The hybridization of the different working methods over three half-days has made it possible to bridge the theoretical presentations given during the week on the methods and fundamentals of the Cressonian approach to understand, modify, and create sound spaces and to apply them in an empirical exercise.

PARAMETRIC TOOL TO SKETCH SONIC AMBIENCES

Elaborating on a variety of sound sketches using Esquis'Sons! adds another dimension in understanding architectural and urban configurations. It opens new perspectives in fabricating and transforming city spaces. Putting the soundscape into debate has enriched and consolidated different sound projections. The proposed intensive one-week exercise helped elaborate rich prospective sound scenarios both in terms of content and presentation. In brief, it was a fruitful exchange!

References

- GAMAL SAID, N.; MARCHAL, T., 2017. Esquisser l'environnement sonore : un enjeu écologique et pédagogique. *Ières rencontres du réseau de l'enseignement de transition écologique dans les ENSA*, Jul 2017, Lyon, France.
- REMY, N.; AMINI, H., BARDYN, J.-L., CHELKOFF, G., GAMAL SAID, N., MARCHAL T., 2016. *Esquis'sons ! Outils d'aide à la conception d'environnements sonores durables*. [Rapport de recherche] 88, Cresson; ADEME, Direction Villes et territoires durables; ENSAG.
- GAMAL SAID, N.; MARCHAL, T., 2017. *Prospectives sonores. Restitution des travaux des participants à l'École d'Hiver*. <https://ehas.hypotheses.org/849>
- MARCHAL, T., *Processus et outils pour la prise en compte des ambiances dans la conception architecturale : un outil d'esquisse des espaces sonores dans le projet d'architecture*, ongoing PhD Thesis.
- MARCHAL, T. 2015. *Esquis'Sons ! : Outil d'esquisse de l'environnement sonore* [Software] <https://hal.univ-grenoble-alpes.fr/hal-01274975>

D1.P2.S2

TECHNOLOGY INTEGRATION AND COLLABORATION I

AGAINST A WORKPLACE CONTAGION

A digital approach to support hygiene-conscious office space planning

MOHAMMED MEKAWY, MOSTAFA A. GABR

*Chair of Architectural Informatics, Technical University of Munich
mohammed.Mekawy@tum.de*

*Chair of Building Technology and Architectural Design, Technical
University of Berlin
m.gabr@win.tu-berlin.de*

Abstract. In today's corporate world, open-plan offices are supposed to enhance the communication and the flow of ideas among workers; however, they have also proven to facilitate the spread of infectious diseases. One approach to solve this problem is adopting spatial planning measures that reduce the risk of infection transmission. This research presents a Multi-Objective Optimization approach to integrate spatial planning measures in open-plan office environments in order to lower the risk of a workplace contagion. These measures were gathered, formalized, parameterized, and coded and integrated into a digital tool. The tool was able to automate the generation and optimization of spatial solutions based on the integrated criteria. The resulting solution space could be easily navigated and filtered to obtain one or more optimum, hygiene-conscious layouts for further development.

Keywords: *Space planning; Open-plan office; Covid-19; Infection transmission; Building Information Modelling; Multi-Objective Optimization; Generative Design*

ملخص. من المفترض أن توفر الفراغات الإدارية ذات المسقط الأفقي المفتوح بيئة محفزة لتبادل الأفكار بين المستخدمين, لكنها في واقع الأمر تيسر أيضاً انتشار الأمراض المعدية بينهم بسهولة. إلا أنه من الممكن التغلب على هذه المشكلة باستخدام حلول فراغية تخفف من خطر انتقال العدوى سريعاً بين الأفراد في هذه الفراغات. هذا البحث يقدم نهجاً جديداً لدمج مجموعة من التدابير التصميمية الهادفة لتقليل خطر العدوى في الفراغات الإدارية مستخدماً تقنية الاستمثال التطوري متعدد الأهداف. وقد تم تطبيق هذا النهج في صورة أداة إلكترونية استطاعت أن تأخذ فراغ إداري خالي وتوفر مجموعة من الحلول المثلى لهذه المشكلة التصميمية بشكل يسهل على المصممين في مراحل التصميم المبكرة استكشاف هذه الحلول وتطويرها والبناء عليها.

الكلمات المفتاحية: التخطيط الفراغي، الفراغات الإدارية ذات المسقط الأفقي المفتوح، جائحة كورونا، انتقال العدوى، نمذجة معلومات المبني، الاستمثال التطوري متعدد الأهداف، التصميم التوليدي.

1. Introduction

The origins of the present day's "open-plan" workspace can be traced back to West Germany's late 1950s when the concept of an "Office Landscape" was first developed and implemented (Pearson-Mims and Lohr, 2000). Proponents of that concept envisaged a space where communication flows freely without being hindered by walls. Yet this original notion has gradually shifted into an exercise of packing more employees into an ever more expensive office space (Richtel, 2020). This presents perfect conditions for infectious diseases to spread, as they traditionally flourish in indoor environments. Studies estimate that 16% of Influenza infections occur in the workplace (Edwards, Tomba and de Blasio, 2016). A study conducted in January and February 2020 in China, 318 Covid-19 outbreaks were studied, and all of them, except one, took place in indoor environments (Qian et al., 2020). These findings should push designers to rethink Open-plan office design. What is required is a sustainable approach towards the planning of a more contagion-resilient workplace.

In the context of the Covid-19 pandemic, the response measures to limit infection transmission could be broadly classified into three categories. The "Administrative" approach, which involves advising a regular disinfection plan, strict hygiene rules, and staggered working hours (CDC, 2020). The "Technical" approach, like installing fever detection cameras, advanced air filtration systems, and touchless fixtures (AIA, 2020). The third approach, which will be the subject of this research, is the "Spatial planning" approach, which comprises spatial aspects of designing an office floor plan to impede the spread of infectious diseases. This research aims to present a digital optimization approach for the spatial planning of open-plan workspaces to mitigate the risks of infection transmission. Spatial planning criteria are coded numerically into a digital tool that can receive an office space and provide preliminary furniture plans that are optimized to meet these criteria.

2. Background

2.1. SPATIAL PLANNING MEASURES

There have been a number of attempts to tackle the "Spatial planning" approach, like the "Covid Space Planner" which uses a semi-automated approach with 2D plans to recommend spatial and furniture plans to mitigate infection risks (Ahmad, 2020). Another approach was devised in "ReRun"

AGAINST A WORKPLACE CONTAGION: A DIGITAL APPROACH TO SUPPORT HYGIENE-CONSCIOUS OFFICE SPACE PLANNING

software, which focuses solely on testing a huge number of 2D configurations of social distancing “bubbles” to identify the optimum arrangement of employee seating (Cousins, 2020). Finally, a geometric approach was developed by Bañón and Bañón (2020), to examine the seat and table distribution for different space uses and space sizes.

This research complements these attempts and compiles data from multiple public guidelines (OSHA, 2020; Perkins&Will, 2020; AIA, 2020), scientific research (Dietz et al., 2020), and simulations done by Japanese researchers using the Fugaku supercomputer, which modeled the flow of virus-like particles from people in different sitting patterns and the amount of exposure in each setting (Swift, 2020). By examining these publications, relevant spatial measures could be broadly summarized as follows: Physical distancing (1.5-2m) has to be kept at all times, access to natural ventilation has to be facilitated, furniture has to be configured in such a way to prohibit face-to-face or back-to-back seating, crowding has to be prevented as far as possible. And these are the measures that this research will address.

2.2. COMPUTER-AIDED SPACE PLANNING

The first approaches to automate space planning using CAD software dates back to the sixties (Armour and Buffa, 1963). Since then, many more attempts were made, which fall broadly into three categories (Liggett, 2000): Single Objective Optimization; used to reach an optimal configuration based on a single criterion, Graph Theory; primarily concerned with generating layouts that fulfill adjacency requirements between zones/activities, and Multi-Objective Optimization (MOO), which attempts to find an arrangement that balances between an adversarial set of constraints and fitness objectives. The MOO approach has been used repeatedly in the space planning domain, for example, to optimize layouts using spatial quality metrics (Bahrehmand et al., 2017), to optimize furniture planning (Yu et al., 2011), and to optimize residential layouts (Wong and Chan, 2009). This approach is well suited to design problems where there is no “single” optimum solution, but many “acceptable” solutions (Flack and Ross, 2011). This makes it ideal for the design problem at hand, where many adverse constraints and objectives need to be balanced and explored in order to arrive at a solution.

3. Approach demonstration

3.1. DESIGN PROBLEM DEFINITION

To demonstrate the research’s approach, a simple design problem was designed, explored, and the results were evaluated. The researchers assumed

an empty open office space, with the windows and doors (as exits and/or as access to amenities) already in place (Figure 1). The aim is to optimize the space planning, with the following objectives in mind:

- Maximize the number of employees in a floor while maintaining physical distancing recommendations for avoiding infections
- No face-to-face or back-to-back seating positions are allowed.
- Maximize physical access to windows for natural ventilation
- Minimizing areas with potential “congestions” in the space, i.e., areas susceptible to overlapping foot traffic from a large number of employees, which increases the potential for close encounters
- Minimizing the travel distance from the employee’s desk to all neighbouring desks, hence reducing the foot traffic in the space.

In the experiment, the following was assumed:

- The workspace layout is rectangular
- The workstation desks are rectangular
- The seating area, windows, and access to exits and amenities are well-defined

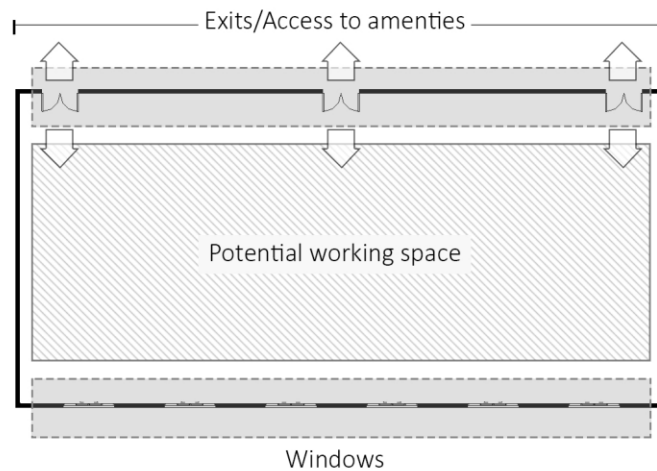

Figure 1. The generic office space used to test the research's approach.

3.2. DESIGN SPACE PARAMETERIZATION

In order to be able to devise an algorithm that can come up with multiple desk configurations, and subsequently evaluate them, the space should be sufficiently parameterized. To do so, a hypothetical modular grid for the placement of desks was established. The modular grid and its parameters are shown in Figure 2, and can be explained as follows:

AGAINST A WORKPLACE CONTAGION: A DIGITAL APPROACH TO SUPPORT HYGIENE-CONSCIOUS OFFICE SPACE PLANNING

First, a circulation zone on the perimeter of the space is placed, so that the area of the actual space available (S_{act}) can be defined as:

$$S_{act} = (L-2a) (W-2a) = L_{act} \times W_{act} \quad (1)$$

Where (L,W) are the length and width of the space respectively, and (a) is the width of the circulation zone, from which we determine the values of (L_{act}, W_{act}), which are the length and width of the actual available space. Next, the actual distance between the individual seating/working positions (D_{act}) can be defined as follows:

$$D_{act} = d + 2p \quad (2)$$

Where (d) represents the value of the appropriate physical distance between individuals, and (p) is the radius of an imaginary bubble of personal space. The value of p is assumed to be 0.3m according to Jocher (2010). Next, and according to the assumption that seating should only be placed on a diagonal pattern, an equilateral triangular grid needs to be established. In geometrical terms, an equilateral triangular grid ensures a fixed distance between vertices. Additionally, an equilateral triangle has the smallest circumradius-to-inradius ratio (Svrtan and Veljan, 2012), and thus minimum surface area and maximum distribution efficiency. The grid is established as follows:

$$U_{grid} = D_{act} \times \cos 60^\circ \quad (3)$$

$$V_{grid} = D_{act} \times \sin 60^\circ \quad (4)$$

Where U_{grid} , V_{grid} represent the “planned” grid spacing in both directions. However, the spacing should conform to the actual values of (L_{act}, W_{act}) for a given value of D_{act} . So the final step is to recalculate the U-subdivisions of the grid ($U_{subdivs}$), and the V-subdivisions of the grid ($V_{subdivs}$) as follows:

For the placement of desks parallel to the L-direction of the space:

$$U_{subdivs} = \lfloor L_{act} \div U_{grid} \rfloor \quad (5)$$

$$V_{subdivs} = \lfloor W_{act} \div V_{grid} \rfloor \quad (6)$$

To place the desks parallel to the W-direction of the space:

$$U_{subdivs} = \lfloor W_{act} \div U_{grid} \rfloor \quad (7)$$

$$V_{subdivs} = \lfloor L_{act} \div V_{grid} \rfloor \quad (8)$$

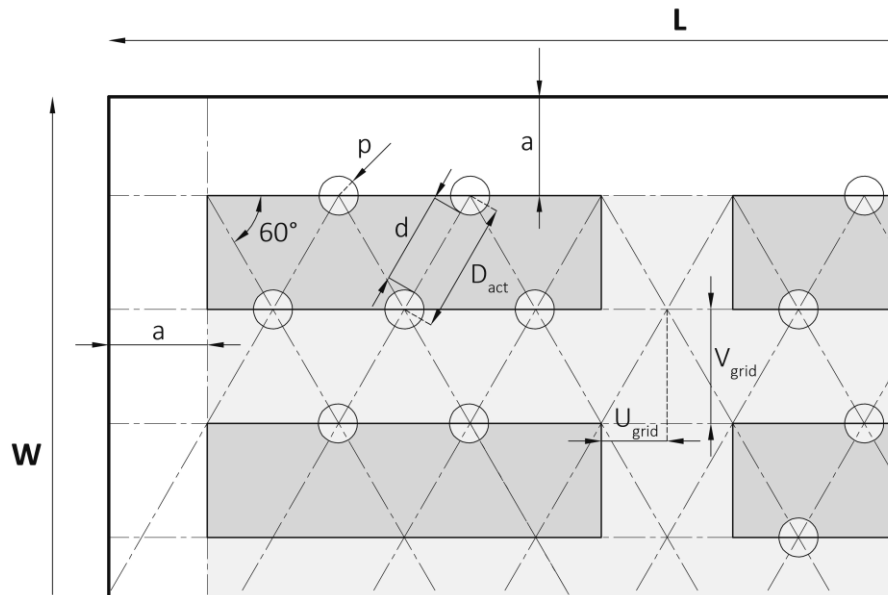

Figure 2. The desk and seating triangular distribution grid and its parameters.

Having established the grid, it is now easy to use it for the placement of the desks and the seating. Desk size can start from two grid modules (U direction) for one employee, up to an assumed desk configuration for 6 employees, occupying seven grid modules. The distance between desks can be assumed to be one grid module (V direction) in the direction perpendicular to the desks and two grid modules (U direction) for the direction parallel to the desks.

3.3. SOLUTION IMPLEMENTATION

A simple Building Information Model (BIM) was built in Autodesk Revit. The research's approach is to utilize BIM data in Revit to extract the required information, the digital computation capabilities of its visual/textual programming platform, Dynamo, for parameterization and calculation, and finally Project Refinery, Autodesk's generative design engine to perform the required MOO to explore the best available solutions for the described design problem. Project Refinery, also known as "Generative Design for Revit and Dynamo", is Autodesk's proprietary platform. It builds on a Dynamo graph and provides an interface for a "Solver" to show design options. At the time of writing, the solver can be based on a random, cross-product, or an evolutionary algorithm (Autodesk, 2019).

The elements of the optimization model are represented in Figure 3. First, model information is extracted; room, openings, and access to Points

AGAINST A WORKPLACE CONTAGION: A DIGITAL APPROACH TO SUPPORT HYGIENE-CONSCIOUS OFFICE SPACE PLANNING

of Interest (POIs). The information is then passed to a group of nodes that perform the necessary calculations to evaluate the design options. So the “variable” input set of parameters becomes: physical distancing value (d), orientation of desks, and a random seed value to create desks with variable sizes. The information is then passed to another group of nodes to create the desk geometry and seating. Finally, this information is analysed to determine their compatibility with the design metrics. These metrics, essentially representing the “Fitness objectives” in the evolutionary solver, are namely:

- Number of workers (*Maximize*): The maximum number of seating positions available for a given desk configuration.
- Window proximity score (*Maximize*): Represents the amount of workers with close proximity to external windows for ventilation
- The “Buzz score” (*Maximize*): This score was practically implemented in a new office space for Autodesk in Toronto (Nagy et al., 2017). The shortest paths from desks to various POIs are measured to come up with a congestion map, which visualizes the spaces where people are likely to cross paths (Figure 4), and a Buzz score, which represents the degree of distribution of these congestions in a floor plan.
- The “Adjacency score” (*Minimize*): The score is analogous to the “Total depth” parameter in the Space Syntax domain (Ratti, 2004). In this research, the Adjacency score is the average of the shortest paths from all seating positions to all other seating positions.

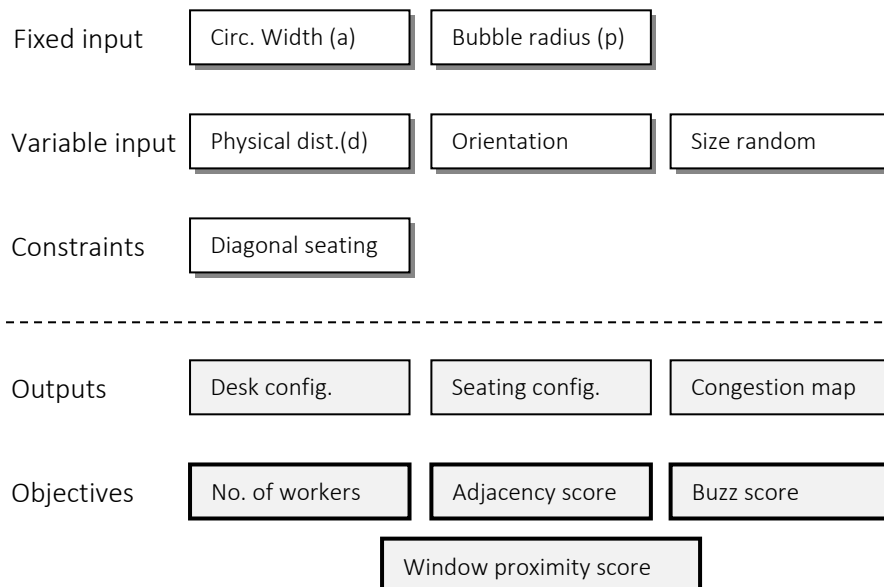

Figure 3. Diagram showing the elements of the developed optimization model

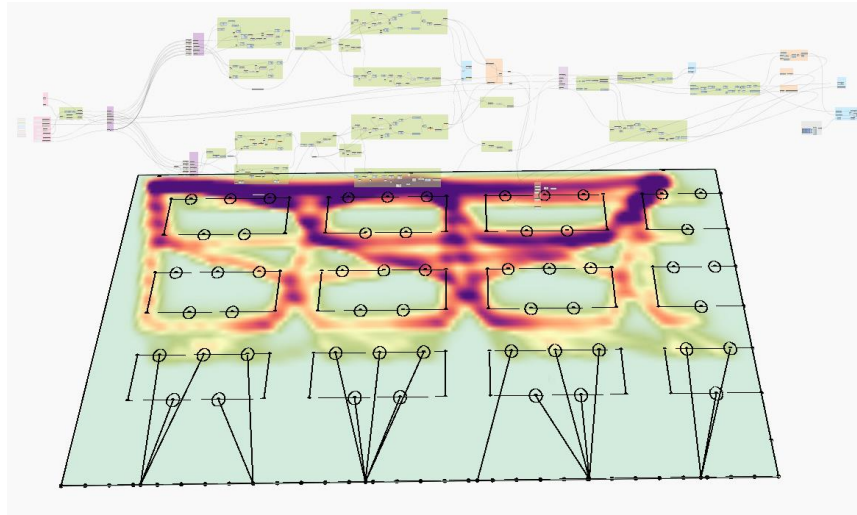

Figure 4. The visual Dynamo output, which shows the designated desk/seating distribution, and the corresponding congestion map.

4. Results

For the example demonstrated here, the variables were set so that the physical distance would vary between 1.5-2.0m, and the random seed of desk generation would vary from 0 to 5000. Refinery's evolutionary solver gives the user the capability to control the population size and the number of generations only. In this example, the population size was set to 200 and the number of generations was set to 20; however, there was no discernible difference found after the 16th generation.

An overview of the results can be seen in Figure 5. By exploring the results, it was found that configurations with desks parallel to the longer side of the space provided more employee capacity; however, they usually performed poorer in terms of the Buzz score. On the other hand, configurations with desks perpendicular to the longer side of the space had, on average, better buzz scores, usually at the cost of the reduction of the number of potential employees. There was however one alternative in the latter set of configurations, which achieved above-average buzz and adjacency scores, and the potential to accommodate 56 employees, one of the highest capacities for employees in the solution space (the highest being 60). Designers could explore the design space further to make sure it complies with these basic spatial rules for mitigating the spread of infections, while experimenting with the workspace layout.

AGAINST A WORKPLACE CONTAGION: A DIGITAL APPROACH TO SUPPORT HYGIENE-CONSCIOUS OFFICE SPACE PLANNING

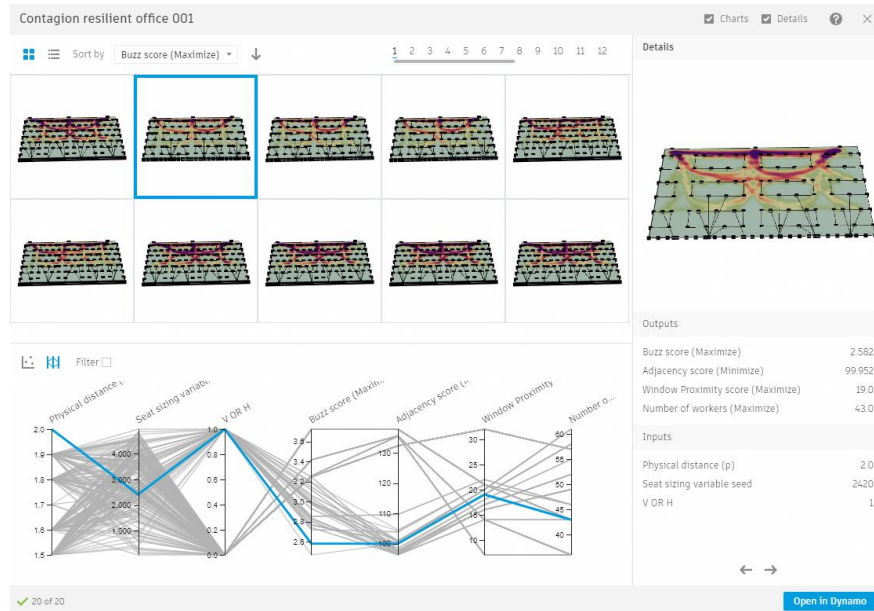

Figure 5. The results of the MOO analysis done in Refinery.

5. Conclusion

This research presented a digital optimization approach to enhance the spatial planning process in open-plan office spaces, with the aim of mitigating the risks of infectious diseases' transmission. Spatial design considerations were gathered from literature and formalized as design objectives and constraints, then further parameterized and represented as numerical values and scores for objective evaluation. The design parameters, constraints, and calculations to derive the scores for the designated design objectives were coded into a digital tool that can receive a BIM model of an office space and provide preliminary furniture plans using a MOO approach. It is obvious that the furniture layouts that can be considered "acceptable", based on this approach, are not considered "ready-to-implement" solutions, because designers need to integrate a multitude of other design factors in their design. This approach can still, however, be useful to help the designer integrate spatial considerations for slowing down a contagion.

References

AHMAD, F. (2020) *covid space planner*. [Online] Digital Blue Foam. Available from : <https://www.digitalbluefoam.com/covidspaceplanner> [Accessed 09/07/20].

- AIA (2020) *Reopening America: Strategies for safer buildings*. The American Institute of Architects.
- ARMOUR, G.C. and BUFFA, E.S. (1963) A heuristic algorithm and simulation approach to relative location of facilities. *Management Science*, 9(2), pp. 294–309.
- AUTODESK (2019) *Generative Design Primer*. Available from : <https://www.generativedesign.org/> [Accessed 02/11/20].
- BAHREHMAND, A. et al. (2017) Optimizing layout using spatial quality metrics and user preferences. *Graphical Models*, 93, pp. 25–38.
- BAÑÓN, L. and BAÑÓN, C. (2020) Improving Room Carrying Capacity within Built Environments in the Context of COVID-19. *Symmetry*, 12(10), p. 1683.
- CDC (2020) *Resuming Business TOOLKIT*. [Online] Centers for Disease Control and Prevention (CDC) [Accessed 09/07/20].
- COUSINS, S. (2020) *Gensler software helps reconfigure workspaces*. [Online] The RIBA Journal. Available from : <https://www.ribaj.com/products/gensler-rerun-physical-distancing-software-helps-uk-return-to-work> [Accessed 09/07/20].
- DIETZ, L. et al. (2020) 2019 Novel Coronavirus (COVID-19) Pandemic: Built Environment Considerations To Reduce Transmission. *mSystems*, 5(2).
- EDWARDS, C.H., TOMBA, G.S. and DE BLASIO, B.F. (2016) Influenza in workplaces: transmission, workers' adherence to sick leave advice and European sick leave recommendations. *The European Journal of Public Health*, 26(3), pp. 478–485.
- FLACK, R.W.J. and ROSS, B.J. (2011) Evolution of Architectural Floor Plans. In: DI CHIO, C. et al. (eds.) *Applications of Evolutionary Computation*. Lecture Notes in Computer Science. Berlin, Heidelberg: Springer, pp. 313–322.
- JOCHER, T. (2010) *Raumpilot: Grundlagen*. Stuttgart, Zürich: Krämerverlag.
- LIGGETT, R.S. (2000) Automated facilities layout: past, present and future. *Automation in Construction*, 9(2), pp. 197–215.
- NAGY, D. et al. (2017) Project discover: an application of generative design for architectural space planning. In: *Proceedings of the Symposium on Simulation for Architecture and Urban Design*. SIMAUD '17. San Diego, CA, USA: Society for Computer Simulation International, pp. 1–8.
- OSHA (2020) *Guidance on Preparing Workplaces for COVID-19*. Occupational Safety and Health Administration.
- PEARSON-MIMS, C.H. and LOHR, V.I. (2000) Reported Impacts of Interior Plantscaping in Office Environments in the United States. *HortTechnology*, 10(1), pp. 82–86.
- PERKINS&WILL (2020) *Road Map for Return – Perkins and Will*. [Online] Perkins&Will. Available from : <https://perkinswill.com/road-map-for-return/> [Accessed 09/07/20].
- QIAN, H. et al. (2020) Indoor transmission of SARS-CoV-2. *medRxiv*, p. 2020.04.04.20053058.
- RATTI, C. (2004) Space Syntax: Some Inconsistencies. *Environment and Planning B: Planning and Design*, 31(4), pp. 487–499.
- RICHTEL, M. (2020) The Pandemic May Mean the End of the Open-Floor Office. *The New York Times*, 4 May.
- SVRTAN, D. and VELJAN, D. (2012) Non--Euclidean versions of some classical triangle inequalities. In: *Forum geometricorum*. pp. 197–209.
- SWIFT, R. (2020) *Japan supercomputer shows humidity affects aerosol spread of coronavirus*. [Online] Reuters. Available from : <https://www.reuters.com/article/us-health-coronavirus-japan-supercompute-idUSKBN26ZOPI> [Accessed 14/11/20].
- WONG, S.S.Y. and CHAN, K.C.C. (2009) EvoArch: An evolutionary algorithm for architectural layout design. *Computer-Aided Design*, 41(9), pp. 649–667.
- YU, L.-F. et al. (2011) Make it home: automatic optimization of furniture arrangement. *ACM Transactions on Graphics*, 30(4), p. 86:1-86:12.

ECO-NUDGING: INTERACTIVE DIGITAL DESIGN TO SOLICIT IMMEDIATE ENERGY ACTIONS IN THE BUILT SPACE

SHERIF GOUBRAN,

*Department of Architecture, School of Sciences and Engineering
The American University in Cairo (Cairo, Egypt)
Email address: sherifg@aucegypt.edu*

CARMELA CUCUZZELLA*

*Department of Design and Computational Arts, Concordia University
(Montreal, Canada)
Corresponding author: carmela.cucuzzella@concordia.ca

AND

MOHAMED OUF

*Department of Building, Civil and Environmental Engineering,
Concordia University (Montreal, Canada) –
Email address: mohamed.ouf@concordia.ca*

Abstract. In the built space, building occupants, their behaviours and control actions are research areas that have gained a lot of attention. This is well justified since energy behaviours can result in differences of up to 25% in building energy consumption. Previous research recommends exploring ways to influence occupants' energy behaviour – through eco-feedback and by directly engaging occupants with building controls. Very little attention has been given to the role digital art and design can play in soliciting and changing human energy-related actions and behaviours in the built space. This paper proposes a new process that combines eco-feedback, gamification, and ecological digital art to trigger occupants to take immediate and precise control actions in the built space. We design, deploy and test this by creating an immersive human-building-interaction apparatus, which we place in a month-long exhibition. This experimental interface was informed by a novel vision for engagement-based human-building interactions deeply rooted in aesthetics, digital art and design. It also uses digital art to mediate between the occupants and energy-performance of spaces by redefining their relationship with and perception of energy – moving

from metrics and quantities understanding to one that is art and emotion-based. The analysis reveals that this new type of human-engagement-based interactive building-control mechanism can add a significant layer of influence on energy-related actions – without revoking the individuals' ability to control their environment. It also highlights digital design and art's power in guiding actions and interactions with the built space.

Keywords. *Human building interactions (HBI); occupant behaviour (OA); ecological feedback (eco-feedback); gamification; energy behaviour; immediate actions.*

ملخص. قد وجد أن سلوكيات شاغلي المباني قد ينتج عنها اختلافات تصل الي 25% من استهلاك الطاقة. وقد تم توجيه الاهتمام للبحث في طرق جديدة لتغيير سلوك شاغلي المباني لتقليل الاستهلاك و الكثافة الاستخدام. وقد كانت الأبحاث السابقة توصي بإيجاد طرق للتأثير على استهلاك الشاغلين عن طريق إشراكهم في محددات المباني من خلال تفاعلات ذكية. ولم يكن هناك الاهتمام الكافي للدور الذي يقوم به الفن الرقمي لتغيير نمط المستعملين للطاقة. هذه الورقة البحثية تقدم وسيلة جديدة لدمج المعلومات البيئية المستمدة بالتناغم مع التصميم الرقمي للتأثير علي شاغلي المباني لاتخاذ خطوات جادة وسريعة لضبط البيئة المبنية. نصمم وننفذ ونختبر فكرة لربط بين الإنسان والبيئة المبنية من خلال تجربة تم عرضها لمدة شهر. هذه التجربة التي بنيت علي الربط بين التفاعل بين الإنسان والمبنى وربطهما معا بالفن والتصميم الرقمي الجمالي. و أيضا استخدمت الفن الرقمي للتوسط بين السكان وأداء الطاقة في الفراغات بإعادة تحديد العلاقة بينهما وبين مفهوم الطاقة وذلك بالانتقال من القياسات المترية والكمية الى قياسات تعتمد علي الفن وترتكز على التفاعل العاطفي. وقد أظهر تحليل هذه البيانات أن آلية التفاعل بين الإنسان والبيئة المبنية يمكنها إضافة أبعاد جديدة للتأثير في تصرفات المستعملين الخاصة بالطاقة بدون تحجيم قدرتهم علي التحكم في بيئتهم المحيطة. وكذلك تلقى الضوء على قدرة الفن والتصميم الرقمي على توجيه التفاعل مع البيئة المبنية.

الكلمات المفتاحية: التفاعل البشري مع المباني، سلوكيات شغري المباني، تفاعلات بيئية، تحكم بيئي للمباني

1. Introduction

In the built space, building occupants, their behaviours and control actions are research areas that have gained much attention. This is well justified since energy behaviours can result in differences of up to 25% in building energy consumption (Stazi *et al.*, 2017). Additionally, building controls are one of the areas that have been rapidly advancing due to the application of new information technologies, such as automation, artificial intelligence and big data (Day *et al.*, 2020). Most of the current work on the topic is focused on predicting occupant behaviour and automating building controls, without intending to change occupants' behaviour nor their modes of interactions with the building and its components (Swaminathan *et al.*, 2018; Tamas *et al.*,

ECO-NUDGING: INTERACTIVE DIGITAL DESIGN TO SOLICIT IMMEDIATE ENERGY ACTIONS IN THE BUILT SPACE

2020). However, these smart building controls' technical, social and ethical challenges are becoming ever more apparent.

On the other hand, eco-feedback, which aims to inform users or actors about the consequences of their actions to reduce negative impacts, has been reported as an effective means for influencing behaviour (Buchanan *et al.*, 2014; Jain *et al.*, 2012; Khosrowpour *et al.*, 2018). Adversely, little attention has been given to studying the design parameters, game-logics, and the logics that can allow feedback technologies to solicit specific behaviours from occupants.

This paper moves beyond the current mainstream building-control automation research and other forms of "smart utopias" (Darby, 2014) to explore a new engagement-based process that combines eco-feedback, gamification, and ecological digital art to trigger occupants to take immediate and precise control actions in the built space. Through this exploration, the paper attempts to answer the following question: *Can real-time artistic eco-feedback be an effective way to trigger targeted indoor environmental control actions?*

2. Background

2.1. CONTROLS AND OCCUPANT BEHAVIOR

Occupants' behaviour and their priorities are influenced by various external factors (Ozcelik *et al.*, 2019; Stazi *et al.*, 2017). Today, many automation and control models, even those proposing what is known as human-in-the-loop controls, assume that discomfort is one of the major drivers for triggering interaction with building controls (Aryal and Becerik-Gerber, 2018; Gupta and Kar, 2018; Park *et al.*, 2019).

While meeting the occupants' comfort expectations appears to be a relevant strategy for smart controls, it might be missing on the potential to direct users to take more environmentally favourable actions. Also, in the context of the global environmental crisis (Jain *et al.*, 2012; Vandevyvere and Heynen, 2014), comfort-focused control approaches disregard many important ecological, ethical (related to prioritizing humans and their over nature or resource consumption), cultural/beliefs and even biological factors (Cole and Brown, 2009). Additionally, many studies have highlighted that occupants willingly accept minor or temporary discomfort – when given the correct, material or psychological, incentive, in the form of rewards or compensations (Deuble and de Dear, 2012; Eichler *et al.*, 2017).

Thus, the question arises, *how can occupants be persuaded to take control actions that are more favourable to the building or the environment?*

2.2. ECOLOGICAL FEEDBACK

Feedback, and ecological feedback in specific, is one of the external parameters known to influence human behaviour in built spaces (2014). Previous work, such as that of Jain *et al.* (2012), has shown that the engagement-character of control interfaces or their interactive-ness is directly linked to possible energy reduction. Other studies have also reported on the success of eco-feedback in raising awareness and possibly creating medium and long-term occupant behaviour changes (Buchanan *et al.*, 2014; Gulbinas and Taylor, 2014; Tiefenbeck *et al.*, 2019).

However, the current work on eco-feedback remains focused on long-term metrics and overall consumption and saving trends. Certainly, the consequences (such as energy savings) are essential to consider in eco-feedback approaches' success. However, little research has attempted to study directly the range of actions that can result from eco-feedback – precisely immediate actions that answer to eco-feedback. Also, very little attention has been given to understanding the role digital art and design can play in the process of soliciting and changing human energy-related actions and behaviours in the built space (Gunay *et al.*, 2014; Orland *et al.*, 2014; Zhuang and Wu, 2019).

While Janda (2011) suggest that we approach eco-feedback in buildings as a form of pedagogy, most published work depends on providing occupants with direct data (such as energy consumption metrics or savings metrics) or messages (such as red indicators for high usage and green indicators for eco-usage, or text information related to comfort or efficiency) (Zhuang and Wu, 2019). This approach is novel and has been barely explored in the built environment – except for the work of (Cucuzzella, 2019; Cucuzzella *et al.*, 2019). Also, little published research have focused on exploring ambient and alternative (i.e. non-technical and non-quantitative) eco-feedback and interfaces – with few exception such as the work of Rodgers and Bartram (2011).

3. Methodology

To answer the proposed research question and to explore the potential of artistic and ambient eco-feedback to trigger targeted, or specific, indoor environmental control actions, we design, deploy and test an immersive human-building-interaction apparatus. We place our experiment in a month-long exhibition. The setup included a living-room-like space, equipped with 3-indoor environment devices (a heater, fan, and 2-lights), and a large screen with a control pad. The large screen allowed for an immersive experience. Each of the 3 devices included a non-invasive AC current sensor. We use

ECO-NUDGING: INTERACTIVE DIGITAL DESIGN TO SOLICIT IMMEDIATE ENERGY ACTIONS IN THE BUILT SPACE

electric current information to create real-time artistic visualizations. We design 3 different profiles (sleep, workout and study) with different target levels for the equipment (for example, in the sleep profile, the heater was set to level 1, and the fan and lights are off). The setup can be seen in Figure 1.



Figure 1. Experiment Setup

The logic of the interface was designed to be simple. When the participants first enter the space, they are prompted to reset all devices to the zero (0) level, pick up the control pad, and select one of 3 profiles. Each of the profiles had its specific device target levels. The artistic visuals moved a cross a spectrum of conditions, between *two opposing extremes*: (1) a state of harmony and (2) a state of agitation. As the devices' settings approach the target levels, the visual would progressively approach harmony. We made the difference between the two states very obvious during the design process. Figure 2 shows an example of the workout profile transition from harmony to out of sync.



Figure 2. The workout visuals in the harmonious, uneasy (intermediate), irritated states (from left to right)

The interaction's goal was for the participants to arrive to a state of harmony by executing control actions on the 3 devices. We gave the participants the option to use hints along the way (which appeared in the form of text on the screen) – to help them achieve the target. When the users were satisfied with the settings, they were required to press "SUBMIT". Figure 3 presents the overall interaction process.

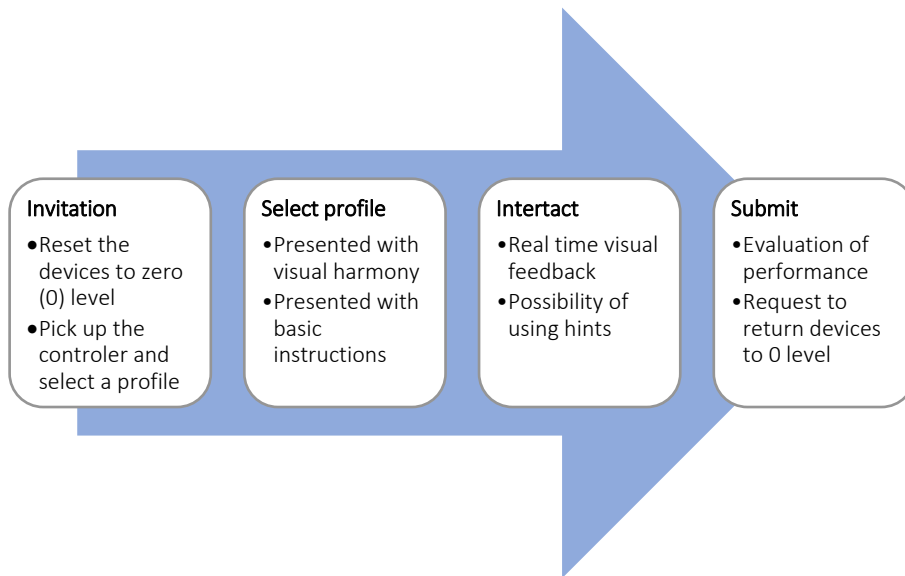

Figure 3. Interaction process

We collect data about the time it took for the users to from the start of the interaction to the moment they submitted, the number of hints used for each interaction, and the 3 devices' levels at the SUBMIT moment. We assess the submitted answer's accuracy, ranging from 3-all correct, 2 or 1 – partially correct, and 0-incorrect. We complemented the quantitative data with informal discussions with the participants.

4. Results and Discussion

4.1. GENERAL RESULTS

We collect 197 data points throughout the month-long setup. The basic data analysis shows that in close to one-third of the cases, the participants were able to arrive at the correct settings for the selected profile. In about 50% of

ECO-NUDGING: INTERACTIVE DIGITAL DESIGN TO SOLICIT IMMEDIATE ENERGY ACTIONS IN THE BUILT SPACE

the time, they figured out one or two of the parameters, and in less than 20% of the cases, they were not able to get to any correct parameters. These results are illustrated in Figure 4 (left).

We find that the average number of hints used was 0.7 (median of 0 hints, and a mode of 0 hints), with a standard deviation of 1.4 hints. The distribution shows most participants did not use any hints (about 65% of the cases) and about 20% of the cases 1 hint was used, and in about 15.75% of the cases two or more hints were used. These findings are illustrated in Figure 4 (right).

The engagement time recorded for the cases had an average of 27.6 seconds and a standard deviation of 24.9. Figure 5 presents the Pareto chart of the engagement time, showing close to 50% of the cases below 20s of engagement time.

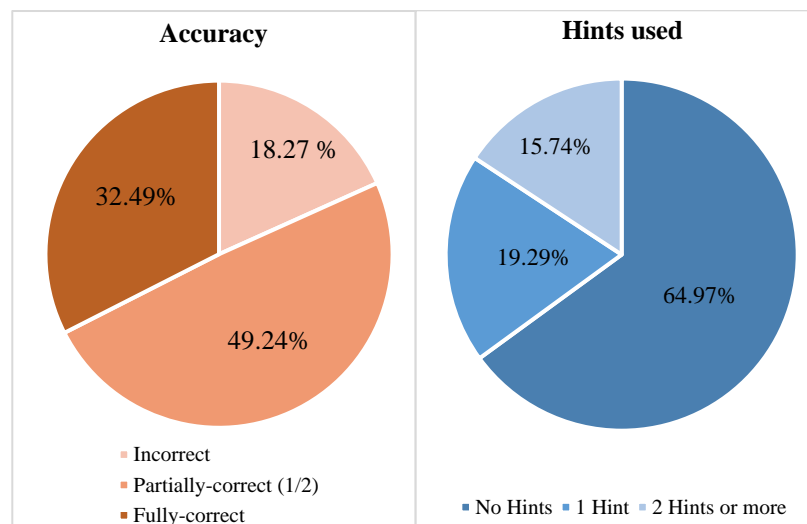

Figure 4. Results – left: accuracy and right: hints used

The results show that the artistic eco-feedback setup we used was able to trigger occupants to take the specific control actions required and reach all or some of the correct parameters in more than 80% of the time. To reach the device levels of the profile required the participants to modify 3 independent devices. It is important to note that the participants did not have earlier knowledge of the required device levels, they did not know how their control actions affect the visuals they saw on the screen, and they had no numerical/quantitative data related to the devices' energy. They also did these control actions with little or no assistance (in the form of hints) and were able to attain outcomes in less than 20 seconds.

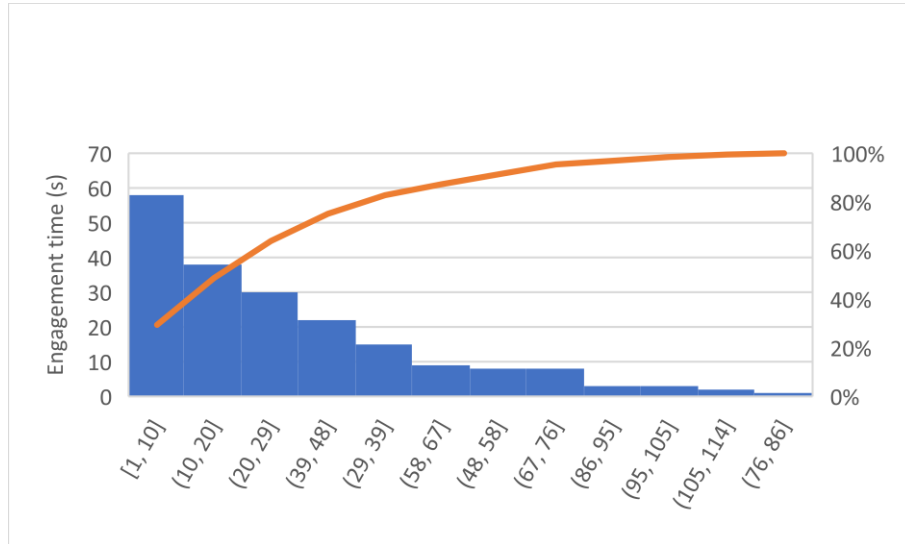

Figure 5. Pareto chart for the engagement time

4.2. CORRELATIONS BETWEEN EXPERIMENT PARAMETERS

Using the Spearman's Rank-Order correlation, we find a highly significant positive correlation between the hints used and the engagement time (i.e. the more hints used the longer the engagement time), a highly significant positive correlation between the hints used and the accuracy (i.e. the more hints used the more accurate the solution), and we find a weak correlation between the engagement time and the accuracy of the solution. These findings are presented in Table 1.

TABLE 1. Correlation between the different variables of the experiment.

		Hints used	Accuracy
Engagement time (s)	R²	0.361	0.169
	p -Value	1.81×10^{-7} ***	0.0177*
Hints used	R²	-	0.434
	p -Value	-	1.97×10^{-10} ***

* $p < 0.05$, ** $p < 0.01$, *** $p < 0.001$

4.3. INFERENCES AND RELATION TO AVAILABLE KNOWLEDGE

The collected measurements and the occupants' discussion revealed a number of important dimensions that are key for developing new modes of interactions

ECO-NUDGING: INTERACTIVE DIGITAL DESIGN TO SOLICIT IMMEDIATE ENERGY ACTIONS IN THE BUILT SPACE

with buildings. These developments have been suggested by Day et al. (2020) and others as an urgent task in the field of smart building controls.

- A. Art and design-based interfaces can help users take actions that are not rooted in their need for comfort. Thus we might consider that interactive eco-feedback tools can trigger users to take actions that would be considered illogical or irrational under normal conditions (O'Brien and Gunay, 2014). For example, we find that occupants have turned on both the fan and heater in a very small space – when triggered by the interface to do so (in more than 50% of the cases requiring such action to occur). While most participants indicated that there was no environmental/comfort motive for changing the devices (since the space environment was controlled), that the heater and fan cause discomfort in the small space, and that the equipment (specifically the fan and heater) were significantly overpowered for room size – they still took actions that contradict these comments.
- B. We find that the priorities of indoor control actions have shifted to meet the profiles selected' requirements. Previous publications, such as Ozcelik et al. (2019), suggested that lighting or visual comfort actions usually take precedence. Our experiment shows that the visual dominance reported by is replaced by thermal or multimodal action dominance when triggered by the interface to do so.
- C. That very little or no "material" rewards (such as monetary or score-based rewards) were needed to trigger participants to take action. Instead, the visual appeal of the art-form acted as a form of psychological incentive mechanism. This is clear since most participants noted that the visual's ambient nature made them appealing to watch.
- D. There is a clear potential to explore building controls and interaction as a form of companionship – where the long-term relationship needs to be developed, maintained and fostered. Such an approach has been studied previously in the "Tamagotchi Effect", where owners developed emotional attachments to their virtual pets.
- E. Janda's (2011) suggestion to consider HBI and building control interfaces as a form of pedagogy is as relevant today as it was 10 years ago. This places building controls and HBI beyond a "simple" engineering or technical problem – referring to complex problems as defined by (Rittel and Webber, 1973). We find that further explorations in the field of design are needed to study the forms, modes and logics of building controls. We propose that exploring the theoretical underpinnings of human-building interactions is necessary to make the technical engineering developments meaningfully applicable in real-world contexts.

While theoretical in nature, this experiment's findings placed the issue of human behaviour in built spaces at the intersection of the fields of design, art, engineering, and education. The findings suggest that, researchers can move away of depending on occupants' knowledge about their long-term energy consumption or savings to concentrate on providing occupants with prompt positive stimuli regarding their short-term energy-actions (de Dear, 2011) – and on ways to deliver immediate action-reward mechanisms through enticing visuals and interactions. This would transition energy eco-feedback from objective reporting to form of coaching (through step-by-step guidance) – where occupants are presented with options to take immediate and precise control actions that are within their means. This contrasts to other messages that are broad in their focus or that fall beyond the user's capacity. Such an approach would also place energy eco-feedback as a for of modern digital companionship – as explored in the work of (Chen *et al.*, 2012; Floridi, 2008; Kumar *et al.*, 2019; Pfadenhauer, 2015).

5. Conclusion

In this research, we investigate the topic of indoor environment building control from an alternative approach. We find that the current focus of most published work is centred on prediction and automation issues. We find that, while there are calls for more interactive and engaging interfaces to be developed, little attention has been given to studying the content, logic and form of eco-feedback in an indoor environment – including non-metric based feedback methods. Additionally, available work is highly focused on analyzing the long- and medium- term consequences of eco-feedback (such as energy savings). However, no work has focused on studying the immediate occupancy control actions that can result from exposure to eco-feedback.

In the face of these gaps, we, designed and deployed a new system that uses art as an ambient eco-feedback mode, intending to trigger occupants to take specific control actions. During the 1 month experiment, we collected close to 200 data points. We found that, despite the abstract nature of the required actions' feedback and ambiguity, participants were successful in attaining the pre-defined target levels for 3 indoor devices. We also found that participants were very efficient and generally accurate when figuring the devices' required setup – with 1 or more of the 3 devices levels set correctly in an average of about 27 seconds.

While the findings here cannot be directly transferable to real-building situations, they highlight that giving users control (as opposed to revoking control through automation), while guiding them to make decisions can translate to positive and accurate control of indoor parameters. Such interaction and engagement-focused control strategy would also develop the

ECO-NUDGING: INTERACTIVE DIGITAL DESIGN TO SOLICIT IMMEDIATE ENERGY ACTIONS IN THE BUILT SPACE

users' awareness of the consequences of their actions and lead occupants to possibly develop meaningful "relationships" with their buildings. The exploration here can help answer the design gaps identified in recent reviews of the topic (Day *et al.*, 2020).

Acknowledgements

We would like to thank Aya Doma for her excellent assistance and insights the statistical analysis. We would like to thank Anghelos Coulon for his work on the software design and setup of the experimental interface. We would also like to thank Gabriel Peña for setting up the experimental space and providing the experience of sitting in a living room. We would like to thank Anna Waclawek of Concordia University's 4th Space for organizing the Cities event.

This research did not directly receive specific grants from funding agencies in the public, commercial, or not-for-profit sectors. However, the researchers would like to recognize the support of the Canadian Social Science and Humanities Research Council for their support, and Sherif Goubran would also like to acknowledge the support received through the Vanier Canada Graduate Scholarship and the Concordia Public Scholar Program.

References

- ARYAL, A. and BECERIK-GERBER, B. (2018), "Energy consequences of Comfort-driven temperature setpoints in office buildings", *Energy and Buildings*, Elsevier B.V., Vol. 177, pp. 33–46.
- BUCHANAN, K., RUSSO, R. and ANDERSON, B. (2014), "Feeding back about eco-feedback: How do consumers use and respond to energy monitors?", *Energy Policy*, Elsevier, Vol. 73, pp. 138–146.
- CHEN, H.M., LIN, C.W., HSIEH, S.H., CHAO, H.F., CHEN, C.S., SHIU, R.S., YE, S.R., *ET AL.* (2012), "Persuasive feedback model for inducing energy conservation behaviors of building users based on interaction with a virtual object", *Energy and Buildings*, Elsevier B.V., Vol. 45, pp. 106–115.
- COLE, R.J. and BROWN, Z. (2009), "Reconciling human and automated intelligence in the provision of occupant comfort", *Intelligent Buildings International*, Vol. 1 No. 1, pp. 39–55.
- CUCUZZELLA, C. (2019), "Eco-didactic design in the public realm", in Mambretti, S. and i Garcia, J.L.M. (Eds.), *The Sustainable City XIII*, Vol. 238, Sustainable City, Valencia, Spain, pp. 283–289.
- CUCUZZELLA, C., HAMMOND, C.I., GOUBRAN, S. and LALONDE, C. (Eds.). (2019), "Du Didactisme en Architecture / On Didacticism in Architecture", *Cahiers de Recherche Du LEAP*, Potential Architecture Books, Montreal, QC.
- DARBY, S.J. (2014), "Smart energy technologies in everyday life. Smart Utopia?", *Energy Research & Social Science*, Vol. 1, pp. 240–241.
- DAY, J.K., MCILVENNIE, C., BRACKLEY, C., TARANTINI, M., PISELLI, C., HAHN, J., O'BRIEN,

- W., *ET AL.* (2020), "A review of select human-building interfaces and their relationship to human behavior, energy use and occupant comfort", *Building and Environment*, Elsevier Ltd, Vol. 178 No. April, p. 106920.
- DE DEAR, R. (2011), "Revisiting an old hypothesis of human thermal perception: alliesthesia", *Building Research & Information*, Vol. 39 No. 2, pp. 108–117.
- DEUBLE, M.P. and DE DEAR, R.J. (2012), "Green occupants for green buildings: The missing link?", *Building and Environment*, Elsevier Ltd, Vol. 56, pp. 21–27.
- EICHLER, A., DARIVIANAKIS, G. and LYGEROS, J. (2017), "Humans in the Loop: A Stochastic Predictive Approach to Building Energy Management in the Presence of Unpredictable Users", *IFAC-PapersOnLine*, Elsevier B.V., Vol. 50 No. 1, pp. 14471–14476.
- FLORIDI, L. (2008), "Artificial intelligence's new frontier: Artificial companions and the fourth revolution", *Metaphilosophy*, Vol. 39 No. 4–5, pp. 651–655.
- GULBINAS, R. and TAYLOR, J.E. (2014), "Effects of real-time eco-feedback and organizational network dynamics on energy efficient behavior in commercial buildings", *Energy and Buildings*, Elsevier B.V., Vol. 84, pp. 493–500.
- GUNAY, H.B., O'BRIEN, W., BEAUSOLEIL-MORRISON, I. and PERNA, A. (2014), "On the behavioral effects of residential electricity submetering in a heating season", *Building and Environment*, Elsevier Ltd, Vol. 81, pp. 396–403.
- GUPTA, S.K. and KAR, K. (2018), "Human-in-the-Loop Thermal Management for Smart Buildings", in J., W. and Mishra, S. (Eds.), *Intelligent Building Control Systems*, Springer, Cham, pp. 191–217.
- JAIN, R.K., TAYLOR, J.E. and PESCHIERA, G. (2012), "Assessing eco-feedback interface usage and design to drive energy efficiency in buildings", *Energy and Buildings*, Elsevier B.V., Department of Civil Engineering and Engineering Mechanics, Columbia University, S.W. Mudd Building, 500 West 120th Street, New York, NY 10027, United States, Vol. 48, pp. 8–17.
- JANDA, K.B. (2011), "Buildings don't use energy: People do", *Architectural Science Review*, Vol. 54 No. 1, pp. 15–22.
- KHOSROWPOUR, A., JAIN, R.K., TAYLOR, J.E., PESCHIERA, G., CHEN, J. and GULBINAS, R. (2018), "A review of occupant energy feedback research: Opportunities for methodological fusion at the intersection of experimentation, analytics, surveys and simulation", *Applied Energy*, Elsevier, Vol. 218 No. September 2017, pp. 304–316.
- KUMAR, P., BRAR, G.S., SINGH, S., NIKOLOVSKI, S., BAGHAE, H.R. and BALKIĆ, Z. (2019), "Perspectives and intensification of energy efficiency in commercial and residential buildings using strategic auditing and demand-side management", *Energies*, MDPI AG, Electrical and Instrumentation Engineering, Thapar Institute of Engineering and Technology, Patiala, Punjab 147004, India, Vol. 12 No. 23, available at: <https://doi.org/10.3390/en12234539>.
- O'BRIEN, W. and GUNAY, H.B. (2014), "The contextual factors contributing to occupants' adaptive comfort behaviors in offices - A review and proposed modeling framework", *Building and Environment*, Elsevier Ltd, Vol. 77, pp. 77–87.
- ORLAND, B., RAM, N., LANG, D., HOUSER, K., KLING, N. and COCCIA, M. (2014), "Saving energy in an office environment: A serious game intervention", *Energy and Buildings*, Elsevier B.V., Vol. 74, pp. 43–52.

ECO-NUDGING: INTERACTIVE DIGITAL DESIGN TO SOLICIT IMMEDIATE ENERGY ACTIONS IN THE BUILT SPACE

- OZCELIK, G., BECERIK-GERBER, B. and CHUGH, R. (2019), "Understanding human-building interactions under multimodal discomfort", *Building and Environment*, Elsevier, Vol. 151 No. December 2018, pp. 280–290.
- PARK, J.Y., OUF, M.M., GUNAY, B., PENG, Y., O'BRIEN, W., KJÆRGAARD, M.B. and NAGY, Z. (2019), "A critical review of field implementations of occupant-centric building controls", *Building and Environment*, Elsevier, Vol. 165 No. May, p. 106351.
- PFADENHAUER, M. (2015), "The Contemporary Appeal of Artificial Companions: Social Robots as Vehicles to Cultural Worlds of Experience", *Information Society*, Vol. 31 No. 3, pp. 284–293.
- RITTEL, H.W.J. and WEBBER, M.M. (1973), "Dilemmas in a general theory of planning", *Policy Sciences*, Vol. 4 No. December 1969, pp. 155–169.
- RODGERS, J. and BARTRAM, L. (2011), "Exploring ambient and artistic visualization for residential energy use feedback", *IEEE Transactions on Visualization and Computer Graphics*, IEEE, Vol. 17 No. 12, pp. 2489–2497.
- STAZI, F., NASPI, F. and D'ORAZIO, M. (2017), "A literature review on driving factors and contextual events influencing occupants' behaviours in buildings", *Building and Environment*, Elsevier Ltd, Vol. 118, pp. 40–66.
- SWAMINATHAN, S., WANG, X., ZHOU, B. and BALDI, S. (2018), "A University Building Test Case for Occupancy-Based Building Automation", *Energies*, Vol. 11 No. 11, p. 3145.
- TAMAS, R., OUF, M.M. and O'BRIEN, W. (2020), "A field study on the effect of building automation on perceived comfort and control in institutional buildings", *Architectural Science Review*, Vol. 63 No. 1, pp. 74–86.
- TIEFENBECK, V., WÖRNER, A., SCHÖB, S., FLEISCH, E. and STAAKE, T. (2019), "Real-time feedback promotes energy conservation in the absence of volunteer selection bias and monetary incentives", *Nature Energy*, Vol. 4 No. 1, pp. 35–41.
- VANDEVYVERE, H. and HEYNEN, H. (2014), "Sustainable Development, Architecture and Modernism: Aspects of an Ongoing Controversy", *Arts*, Vol. 3 No. 4, pp. 350–366.
- ZHUANG, X. and WU, C. (2019), "The effect of interactive feedback on attitude and behavior change in setting air conditioners in the workplace", *Energy and Buildings*, Elsevier B.V., Vol. 183, pp. 739–748.

BUILT-IN IMMERSIVE VR TECHNOLOGY FOR DECISION-MAKING IN DESIGN AND SIMULATION OF A FLEXIBLE SHADING DEVICE

ODYSSEAS KONTOVOURKIS, ANDREAS KONSTANTINOU,
NIKOS KYRIZI

University of Cyprus, Department of Architecture, Nicosia, Cyprus

*Email address: kontovourkis.odysseas@ucy.ac.cy,
antreas.au.79.93@gmail.com, nikos.kyrizi@gmail.com*

AND

PANAGIOTA TZIOURROU

Email address: Ptziourrou@gmail.com

Abstract. This paper discusses the potential offered by Virtual Reality (VR) and accompanied gesture-based devices as tools for architectural design and simulation. This is done by outlining a workflow and by demonstrating an experimental study for the development of an interactive, flexible and parametric shading device consisting of bending-active wooden strips. More specifically, the project focuses on the relationship between physical inputs acquisition and virtual experience of two users in space. Through the use of Kinect and VR headset, the first user is responsible to check and control the shading system regarding the shape and sun direction. The aim is to create configurations that serves his/her shading needs by moving his/her hand in order to hide the sun in a game like procedure until satisfactory shading is acquired. The second user, through the use of a leap motion sensor and a projection screen, is able to check and control the efficiency of structure in terms of bending behavior and environmental impact, also in a loop of possibilities. Using the thump and pointer fingers he/she controls the bending behavior by watching a screen that shows in different colours the bending factor of each element. At the same time, the distance between his/her hands controls the number of elements in order to achieve the optimal rate between material consumption and shading. The two users can intervene sequentially or concurrently during the process. A series of investigations related to shading rate and bending behavior as well as minimum material consumption leading to lower environmental impact are conducted. This attempts to offer useful conclusions as regard the potential application of immersive VR technology as

BUILT-IN IMMERSIVE VR TECHNOLOGY FOR DECISION-MAKING IN DESIGN AND SIMULATION OF A FLEXIBLE SHADING DEVICE

mechanism for decision-making in architecture and simulation but also in the fabrication of the suggested shading device.

Keywords: *Virtual reality, simulation, interactive shading device, design decision making.*

ملخص. تناقش هذه الورقة البحثية الإمكانيات التي يوفرها الواقع الافتراضي (VR) والأجهزة القائمة على الإيماءات المصاحبة كأدوات للتصميم المعماري والمحاكاة. يتم ذلك من خلال تحديد سير العمل وإثبات دراسة تجريبية لتطوير جهاز تظليل تفاعلي ومرن ومحدود يتكون من شرائط خشبية نشطة الانحناء. بشكل أكثر تحديداً، يركز المشروع على العلاقة بين اكتساب المدخلات المادية والتجربة الافتراضية لاثنتين من المستخدمين في الفراغ. من خلال استخدام سماعات الرأس Kinect و VR، يكون المستخدم الأول مسؤولاً عن فحص والتحكم في نظام التظليل فيما يتعلق بالشكل واتجاه الشمس. والهدف هو إنشاء تكوينات تخدم احتياجات التظليل من خلال تحريك اليد لإخفاء الشمس في عملية أشبه باللعبة حتى يتم الحصول على تظليل مرضٍ. يمكن للمستخدم الثاني، من خلال استخدام مستشعر حركة وشاشة عرض، التحقق من الكفاءة الإنشائية والتحكم فيها من حيث سلوك الانحناء والتأثير البيئي، وأيضاً في إطار حلقة من الاحتمالات. باستخدام أصابع الإبهام والمؤشر، يتحكم المستخدم في سلوك الانحناء من خلال مشاهدة شاشة تظهر بألوان مختلفة عامل الانحناء لكل عنصر. في الوقت نفسه، تتحكم المسافة بين يديه في عدد العناصر من أجل تحقيق المعدل الأمثل بين استهلاك المواد والتظليل. يمكن أن يتدخل المستخدمان بشكل تسلسلي أو متزامن أثناء العملية. يتم إجراء سلسلة من التحقيقات المتعلقة بمعدل التظليل وسلوك الانحناء بالإضافة إلى الحد الأدنى من استهلاك المواد مما يؤدي إلى تقليل التأثير البيئي. يعرض البحث من هذه التجارب لتقديم استنتاجات مفيدة فيما يتعلق بالتطبيق المحتمل لتقنية الواقع الافتراضي الغامرة كآلية لصنع القرار في الهندسة المعمارية والمحاكاة أيضاً في تصنيع جهاز التظليل المقترح.

الكلمات المفتاحية: الواقع الافتراضي، المحاكاة، جهاز تظليل تفاعلي، آلية اتخاذ القرار التصميمي.

1. Introduction

Virtual, Mixed and Augmented Reality (VR MR and AR) are in the forefront of the computational methods applied in architecture and engineering field for spatial perception, navigation, appreciation and generally for incorporating users in virtual or mixed worlds and for enhancing collaboration between users and digital spaces (Chan, 1997; Sampaio and Henriques, 2008). Thus, today different directions in the application of these technologies can be found, mainly in research, teaching and training of students and architects. Within this framework, the importance of immersive technology as a novel approach used in various stages of design and construction in order to enhance and promote interdisciplinarity and active involvement of stakeholders/users is recognized and, in several examples, is introduced and applied (Wang et al., 2018).

Regarding their application as mechanisms for education and training, several directions of implementation can be found, recognizing the role and benefits of immersive technology, which can bring in higher education (Radianti et al., 2020). According to Wang et al. (2018) these directions include 1. Architecture visualization and design education, 2. Construction safety training, 3. Equipment and operational task training and 4. Structural analysis education. More specifically, within architectural design/structural analysis education and training context, their application has been discussed in several case study examples.

In regard to architectural design, examples showed the potential of immersive technology as a digital medium for perception and visualization of architectural spaces but also as a virtual method to support architectural design, landscape architecture and environmental planning (Portman et al., 2015). In other cases, for instance in the work by Jelvard and Mullins (2019), the application of VR as tool for lighting design was discussed and in the work by (Akin et al., 2019) the application of MR examined a performative design development.

Also, several examples demonstrated their application in the area of construction for inspection, prediction and safety (Li et al., 2018). Moreover, examples integrated immersive virtual reality with gestures and haptics that were accompanied by physics-based simulation. Thus, examples demonstrated the introduction of haptics with sensation of touch of physical behaviour in an attempt to integrate in reliable way immersive and physical environment and provide a sense of users' interaction in the virtual environment (Radianti et al., 2020; Wang et al., 2018). This integration could take different forms and expressions. For instance, in the work by Kontovourkis and Stroumpoulis (2019) a VR methodology was applied for the prototyping of compression-only structures by simulating their physical behaviour based on physics-based principles. In another example, AR technology was applied to guide bending of construction components (Fologram, 2020).

Although, immersive technologies integrated with gesture and haptic devices have been used extensively in architectural design and construction, they have been mostly applied as perception and inspection mechanisms in the later stages of architectural design and construction processes. In addition, limited work has been observed regarding their application as flexible and dynamic mechanisms, which can be applied in the initial stage of the design process, allowing decisions to be made regarding architectural and construction planning (Klerk et al, 2019).

This paper outlines a built-in immersive VR technology application workflow for decision-making in design and simulation of an interactive and flexible shading device consisting of bending-active wooden strips. The suggested system can be placed in the frame of a window in order to control the relation between occupants' position and sun direction. In addition, it

BUILT-IN IMMERSIVE VR TECHNOLOGY FOR DECISION-MAKING IN DESIGN AND SIMULATION OF A FLEXIBLE SHADING DEVICE

intends to enable the collaboration between two users in the process of design decision-making.

Specifically, the suggested workflow is divided in three stages, the collection of data, the computational process and the immersive VR control. The collection of information (data) is based on the interactive capacity of users with the physical environment, using a Virtual Reality headset and a Leap Motion controller. In the second stage, the integration of human body and hands movement of the two users by the data collection mechanisms allows the detection and analysis of information, providing initial guidelines in which the shading device will be developed. In the third stage, the immersive VR control allows a series of results to be obtained, providing in parallel the design limits of bending-active wooden strips and the framework for their fabrication using an industrial robot.

2. Workflow process

The suggested workflow is divided into three main stages, which include the import of physical data, the computation and the export of information that is analyzed and projected into the physical world. Specifically, as first stage, the physical data is introduced into the digital world through two devices, the Kinect and the Leap Motion controller. Then, communication is established between the physical and digital world, where the data is sorted. In the second stage, physical behavior using the programs Firefly, Python, Kinect SDK and Leap Motion Orion Setup is conducted. At the same stage, constraints are introduced and the digital data is sorted, controlled and processed using Grasshopper plug-in for Rhino. In the same stage, results are investigated using Tortuga and Kangaroo plug-ins for Grasshopper. Also, geometrical data are processed for simulation of robotic fabrication using Taco ABB plug-in. Finally, as third stage, data is exported and perceived by the two users on a 2D screen based on a conventional projector and on virtual environment using a VR Headset device. In parallel, fabrication data are exported for robotic physical execution (Figure 1).

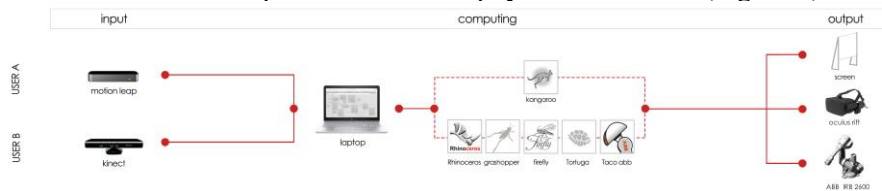

Figure 1. Methodological workflow

3. Experimental set-up

3.1 USERS

As it has been described, two users are involved in the workflow. The users collaborate to explore desirable shapes of the wooden shading device, which can be located on a rectangular window frame. Information derived from design decision-making and simulation allows possible fabrication of ideal forms through an industrial robot.

The first user wears the VR headset and interacts with the Kinect device, that captures his/her skeletal physical behavior. At the same time, he/she can perceive the design results in the virtual world. The second user stands in front of a table and interacts with the Leap Motion device, that captures his/her fingers' physical behavior. Similarly, he/she perceives the results of interaction on a 2D screen in the physical world (Figure 2).

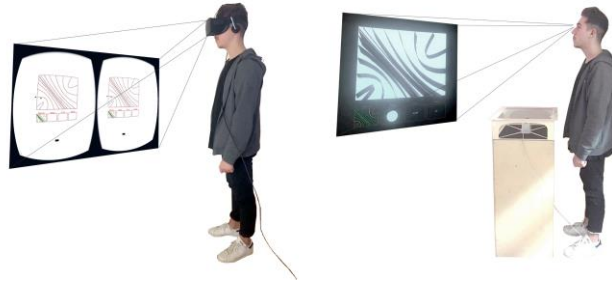

Figure 2. First user with VR headset and second user in front of the leap motion device.

Users play two different roles in the project, as the process progresses. The first user defines the direction of solar radiation compared with the shading device and his/her body location in space. In this way, he/she defines the point and the range from which the sun's rays enter the window and creates the pattern. The second user, acts as the person responsible to control the structure and its bending limits. He/she intervenes on the morphology of the pattern, which is defined by the first user, and modulates according to the static requirements of the structure. Once the shape is set and locked by both users, fabrication data is set for industrial robot simulation and execution (Figure 3).

BUILT-IN IMMERSIVE VR TECHNOLOGY FOR DECISION-MAKING IN DESIGN AND SIMULATION OF A FLEXIBLE SHADING DEVICE



Figure 3. Physical action and digital simulation of the two users.

The two users can intervene sequentially or concurrently in the evolutionary process. They can also act and shape the pattern of the structure in real time and examine the results of robotic simulation.

3.2. PROCESS STEPS

As mentioned above, the first step includes the importing of physical data, the establishment of communication between the physical movements and digital computation as data and the classification of them.

The first user, wearing the virtual reality headset device, stands in front of the Kinect camera. When the user lifts his/her right leg over 30 cm, the digital pattern starts to interact with the movement of his/her right hand. His/her right-hand movement defines the sun direction, with a hiding sun movement of his/her hand, and controls the shape. Specifically, the Kinect camera tracks the hand position and translate it in digital data through SDK toolkit. Using the Kinect SDK software and the Firefly plug-in for Grasshopper, the first user jumps into the digital environment. This common movement of hiding the sun with our hand when sun's rays bother our eyes is used to defined the point from which the sun's rays come into the room and the range/area around it, where the pattern has to act (Figure 4).

The second user, in front of the supporting device, where the Leap Motion sensor is embedded, places his/her hands and moves his/her figures. When he/she lifts his/her hand above the sensor, the digital shape of the pattern starts to interact with the movement of his/her fingers. His/her thumb and pointer fingers of both hands control the system. When he/she extends his/her hands the system expands, on the other hand when he/she bring closer his/her hands the system compresses. In addition, by closing his/her thumbs and pointer fingers the bending elements bend and by expanding his/her fingers the elements are released. These gestures were strategically selected to simulate the bending of an element and the expansion of the system because are connected with the actions that someone needs to do in real life for the same results. These figures define the range of the spread and control the curvature of the first and the last bending-active wooden strips,

where between them the rest wooden members are parametrically shaped. The Leap Motion sensor tracks the fingers positions using the Firefly plug-in for Grasshopper. Thus, the scale and distance between all members of the shading pattern are defined (Figure 5).

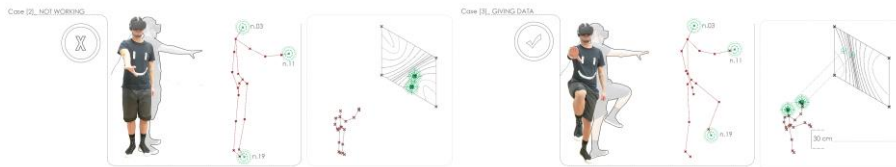

Figure 4. First users and his/her interaction with the system in the digital environment.

As soon as the first user interacts with the system, his/her physical behavior is simulated in Grasshopper. Then the second user has to define the structural context and the pattern axis. The position of his/her four fingers are translated in four points on the window surface. Then, a line is created, that defines the pattern's direction axis. The first user must land his foot to the ground to lock his decision. Similarly, the second user must move his hands at the height of 25cm or above the sensor to lock his decision. As a result, the form of the pattern is locked by the two users respectively (Figure 5).



Figure 5. Second user and his/her interaction with the system in the physical environment.

When the optimal form of the bending-active wooden shading device is locked by the users, an investigation of its bending behavior, CO₂ emission, and shadow rate is followed, using the Kangaroo and the Tortuga plug-ins for Grasshopper in combination with Occlusion, Gradient, and other supportive components. Specifically, by using the Kangaroo plug-in, a live physics engine, the simulation of the bending behavior of each wooden strip is achieved, eliminating any discrepancies between its physical and digital behavior. In detail, the curves of wooden strips generated during interaction of users, are introduced into the physics engine as lines with angle points. Their ending points are moved toward the center, while a bending force is exerted on the curves. In this way, a bending curve, similar to the physical wooden curve, is created. Alongside, an experiment with real wooden strips is performed, in order to identify boundaries of simulation (Figure 6).

BUILT-IN IMMERSIVE VR TECHNOLOGY FOR DECISION-MAKING IN DESIGN AND SIMULATION OF A FLEXIBLE SHADING DEVICE

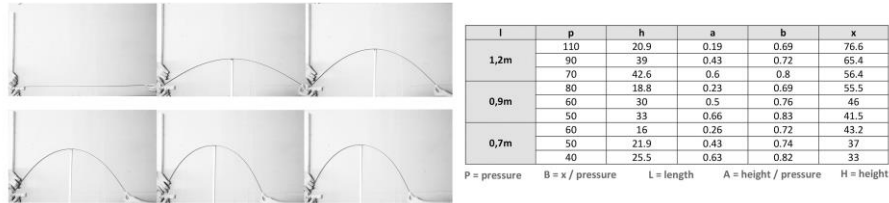

Figure 6. Results of physical bending-active behavior experimentation.

The Tortuga plug-in evaluates the Life Cycle Analysis and Global Warming Potential (CO₂e) of the Grasshopper model. Geometrical and volume data associated with the wooden shading device is used as input, while at the same time the material data from the Tortuga material library is used, in order to count the mass of wood and then the values of Global Warming Potential in CO₂e.

Finally, the shadow rate is displayed, which shades the area around the first user's head and the window area. Also, the efficiency of wooden patterns is presented by coloring the shaded points.

As a result, both users observe in their displays a series of measurable data that represent the whole procedure. The limits of bending curves (green for low and red for high bending strength), the CO₂e values, the percentage of shading in the head of the first user and the percentage of shading in the window surface. The results assist users in deciding the most ecological solution and the best performing shape in each situation, thus evaluating design results based on criteria that meet real life data and needs.

3.3 SCENE SETUP

The overall workflow process is organized based on a scene setup, where the devices and the users interact to achieve the overall behavior in physical and digital environments. The main components that consist the projection part of the scene are, the laptop, from where all the data are processed, a screen with the dimensions of 165cm x 130cm, where the pattern and digital data are projected and the projector, that is placed within a distance of 2m in front of the screen. At the same time, a Kinect camera is part of the scene, a Leap Motion sensor is embedded in a supporting device and a Virtual Reality Headset (Oculus Rift) is used (Figure 7).



Figure 7. Scene setup where users and devices interact.

4. Case study results

A case study is conducted in order to investigate design possibilities and demonstrate results, which include the curvature of each element that is represented by a graphic diagram (under and over bending limitation with green and red colours respectively). Also, the CO₂e emission, the shadow on the window screen (percentage) and the shadow on the user head level (percentage). In each case, the users observe the displayed results and control the process to create the best shape for each sun direction.

In this section, two representative phases of the case study are presented. In each phase, the number and the extrusion of elements remain constant but two different human gestures are implemented. The first phase is developed according to the sun direction and the second one according to the technical specification of the material. The two phases are separated for better understanding of the experiment; otherwise the two users can control the results of shading device at the same time.

In phase A (Figure 8), the first user, through gestures, responses to two cases of sun direction (same season but different time). In this phase, the hand direction controls the angle of pattern for maximum percentage of shadows in his head.

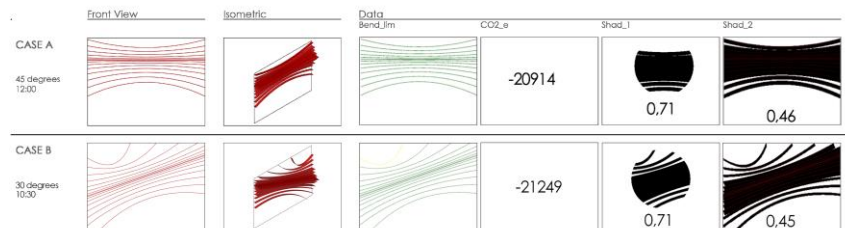

Figure 8. Phase A – First user investigation results.

BUILT-IN IMMERSIVE VR TECHNOLOGY FOR DECISION-MAKING IN DESIGN AND SIMULATION OF A FLEXIBLE SHADING DEVICE

In phase B (Figure 9), the second user holds the device consisting of 4 rings (for the index finger and thumb for each hand) and three bending elements that control the pattern. In this phase, the user controls the expansion of the pattern for the best CO₂e emission and bending behavior of elements (appropriate curvature and constructable elements in green). In case A, the user extends and bends the elements to its limit. In case B, he/she compresses their expansion and reduces their bending factor. In this investigation, case A was selected because of the lower CO₂e emissions and higher shadow percentage in both user's head and window surface.

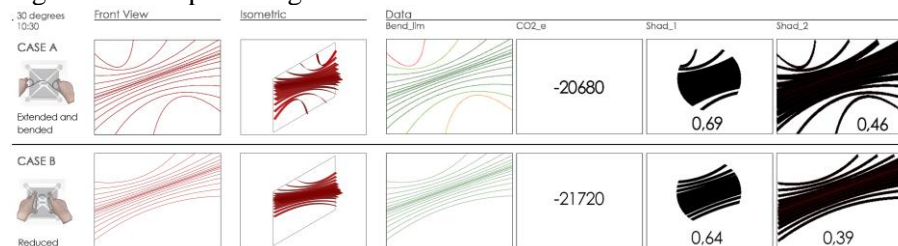

Figure 9. Phase B – Second user Leap Motion investigation results.

5. Conclusions

Consequently, the rapid evolution of digital technology enables us, not only to accomplish tasks that were not achievable in the past but also to reach them more efficiently. Regarding the case study cited in this paper, the challenges are the translation of the physical inputs to digital data, and vice versa, resulting digital processing and physical outputs. In this way, a mechanism of decision-making with a feedback-loop is established between two users, in order to create the most optimal outcomes.

Turning the focus on the data exchange between the physical and digital world, on the one side, Kinect and Leap Motion controller are used to record the physical data of the two users and simultaneously through computational processing to extract the required results. On the other side, Virtual Reality components allow the user to interact with that results as he/she enters the virtual world and takes part in the digital design process.

Furthermore, the roles of different stakeholders, for instance clients, architects, constructors, etc., as it is described in this study, reflect a fundamental collaboration approach between them, not only for the completion of a project but also for an optimal result that considers a number of criteria.

Acknowledgements

This work has been developed for the requirement of the postgraduate course ARH-522 – Advanced Computer-Aided Design Topics in the Department of Architecture at the University of Cyprus during the Fall 2017, taught by Odysseas Kontovourkis, Assistant Professor of Architecture. The team members were the Diploma students Andreas Konstantinou, Eleftherios Kaimakliotis, Giannos Koliandri, Ioanna Hadjipieri, Nikos Kyrizi and Panagiota Tziourrou. The methodology, the results and the conclusion discussed in this paper are the authors' view.

References

- AKIN, S., ERGUN, O., DINO, I.G., SURER, E., 2019. Improving Visual Design Perception by an Integrated Mixed Reality Environment for Performative Architecture. In: N. STEINØ, M. KRAUS, eds. *7th eCAADe RIS: Virtually Real. Immersing into the Unbuilt, 2-3 May Aalborg*. 47-56.
- CHAN, C.S., 1997. Virtual Reality in Architectural Design. In: Y. LIU, J. TSOU, J. HOU, eds. *CAADRIA'97 Workshops, 17-19 April 1997 Hsinchu*. 1-10.
- DE KLERK, R., DUARTE, A.M., MEDEIROS, D.P., DUARTE, J.P., JORGE, J., LOPES, D.S., 2019. Usability studies on building early stage architectural models in virtual reality. *Automation in Construction*, 103, 104-116.
- FOLOGRAM. Accessed 08.11.2020. <https://community.fologram.com/t/bending-active-structures-in-augmented-reality/446>
- JELVARD, P., MULLINS, M.F., 2019. The use of VR technologies to enhance methods for lighting design practice. In: N. STEINØ, M. KRAUS, eds. *7th eCAADe RIS: Virtually Real. Immersing into the Unbuilt, 2-3 May Aalborg*. 97-102.
- KONTOVOURKIS, O., STROUMPOULIS, A., 2019. Virtual Reality for prototyping compression-only structures. In: N. STEINØ, M. KRAUS, eds. *7th eCAADe RIS: Virtually Real. Immersing into the Unbuilt, 2-3 May Aalborg*. 5-14.
- LI, X., YI, W., CHI, H.L., WANG, X., CHAN, A.P.C., 2018. A critical review of virtual and augmented reality (VR/AR) applications in construction safety. *Automation in Construction*, 86, 150-162.
- PORTMAN, M.E., NATAPOV, A., FISHER-GEWIRTZMAN, D., 2015. To go where no man has gone before: Virtual reality in architecture, landscape architecture and environmental planning. *Computers, Environment and Urban Systems*, 54, 376-384.
- RADIANTI, J., MAJCHRZAK, T.A. FROMM, J., WOHLGENANT, I., 2020. A systematic review of immersive virtual reality applications for higher education: Design elements, lessons learned, and research agenda. *Computers & Education*, 147, 103778.
- SAMPAIO, A.Z. and HENRIQUES, P.G., 2008. Simulation of construction processes within virtual environments. In: J. BRAZ, N.J. NUNES, J.M. PEREIRA, eds. *Third International Conference on Computer Graphics Theory and Applications Conference, 22-25 January 2008 Funchal, Madeira*. 326-331.
- WANG, P., WU, P., WANG, J., CHI, H.L., WANG, X., 2018. A Critical Review of the Use of Virtual Reality in Construction Engineering Education and Training. *Int. J. Environ. Res. Public Health*, 15, 1204.

BIM EXECUTION PLAN (BEP) TO INFRASTRUCTURE SUPERINTENDENCE OF THE FEDERAL UNIVERSITY OF PERNAMBUCO

A proposal to implement BEP in a Federal University in Brazil

ISABELLA RODRIGUES, MAX ANDRADE
Federal University of Pernambuco, Av. Prof. Moraes Rego, 1235 -
Cidade Universitária, Recife, Pernambuco, Brazil
Email address: isabella.rodrigues@ufpe.br
Email address: max.andrade@ufpe.br

Abstract. This paper shows a proposal to implement a BIM Execution Plan (BEP) as an instrument for the successful BIM diffusion. BEP specifies the scope required for implementation, identifies processes, defines exchanges of information and describes needs of the design project to provide adequate support for BIM implementation. The proposed BEP is to be implemented in the Design Sector of a Brazilian Public University. It started with a diagnosis, choosing a pilot design project, defining the team to propose a BEP. This work presents the result of this BEP implementation, showing the benefits and the importance for the design project sector of the University.

Keywords: Building Information Modeling (BIM); BIM Execution Plan (BEP); BIM implementation in public company; Process project with BIM.

ملخص. تعرض هذه الورقة اقتراحاً لخطة تنفيذ نمذجة معلومات المبنى (BEP) كأداة لنشر تقنية الـ BIM بنجاح. تحدد خطة التنفيذ النطاق المطلوب للتنفيذ، كما تحدد العمليات ومتطلبات سير العمل وعمليات تبادل المعلومات وتصف احتياجات مشروع التصميم لتوفير الدعم الكافي لتنفيذ نمذجة معلومات المبنى بصورة فعالة. سيتم إطلاق خطة التنفيذ المقترحة في قطاع التصميم في جامعة برازيلية عامة. وقد بدأت بالتشخيص واختيار مشروع تصميم تجريبي وتحديد فريق العمل لاقتراح خطة التنفيذ. يقدم هذا العمل نتيجة تفعيل تلك الخطة، موضحاً الفوائد والأهمية لقطاع مشروع التصميم في الجامعة.

الكلمات المفتاحية. نمذجة معلومات البناء، خطة تنفيذ الـ BIM، تطبيق الـ BIM في شركات عامة، مشاريع وعمليات التصميم باستخدام الـ BIM.

1. Introduction

The current Brazilian scenario is still lacking when it comes to the implementation of BIM. BIM practices are not widespread, and are often misinterpreted, which has resulted in several cases of unsuccessful BIM execution. This is mainly due to the lack of knowledge of design managers and companies directors about the real needs that are linked to BIM practices in the design project (Leusin, 2018). It is also very common for BIM to be associated only with the use of object-based modeling tools, the well-known as BIM Platforms (Revit, Archicad, OpenBuilding, among other software). On the other hand, several national initiatives have stimulated the adoption of BIM in Brazil. Among these, we highlight Decree Federal Law No. 10,306, of April 2, 2020. This strategy is supported by several indicators that aim to guide the process of implementing BIM over 10 years in Brazilian federal public enterprises.

As a strategy to reduce risks and increase efficiency in BIM implementation, there is BIM Execution Planning (BEP). BEP is a BIM implementation manual in a planned and scaled way in order to achieve the objectives defined for BIM. This aims to bring clarity and transparency to the BIM implementation process (MESSNER et al., 2019).

It is within this context that the present work is inserted. This was developed as part of a Conclusion Work for the Undergraduate in Architecture and Urbanism Course. The goal is to assist the Infrastructure Superintendence (SINFRA) of the Federal University of Pernambuco (UFPE) in the introduction of BIM, through the creation of a BEP. SINFRA is a UFPE body whose purpose is the planning and administration of the built works and the use of the physical spaces of this university. UFPE is a Brazilian Federal Public University that is among the 10 largest universities in Brazil and has about 35 thousand students in undergraduate, master's and doctoral courses.

The work to be presented in this paper aims to present the stages used for the construction of a BEP at SINFRA, whose emphasis was on the creation of an architectural and complementary design project in the design development phase for the construction of an extension to an existing building on the campus of UFPE. The specific objectives of this paper are: To present the steps used to create a BEP for the realization of a design development phase (architecture and complementary) with SINFRA; Describe the design project flows, collaboration models and types of deliverables needed to create the BEP presented in this paper.

2. Building Information Modeling and BIM Execution Planning

As a means of encouraging the implementation of BIM, several efforts have been made in private and public companies. These efforts range from the creation of guides to the rules and tenders that require the use of BIM. United States, United Kingdom, Finland, Singapore, Norway and Hong Kong are pioneering countries in publishing guides with guidelines for BIM implementing. These guides include: Getting Started with BIM (NATSPEC, 2014); Building Information Modeling Roadmap (USACE and ERDC, 2006); National Building Information Modeling Standard (NIBS, 2007); National Building Information Modeling Guide 01-07 (GSA, 2006-2015); BIM Guide for Germany (Federal Office for Building and Regional planning, 2013); CIC Building Information Modeling Standards (Construction Industry Council, Hong Kong, 2015); BIM Guideline Standard (Public Works Department, Malaysia, 2016); Statsbygg Building Information Modeling Manual Version 1.2.1 (Statsbygg, 2017); 3D Working Method (Agency for Enterprise and Construction, Denmark, 2006) among others.

In Brazil, through non-governmental initiatives or governmental initiatives (federal, states and municipals), multiple subjects are discussed, such as fundamental BIM concepts, good practices, national standards, to develop libraries and templates. However, only a few have a direct implementation approach. In the Brazilian context, there are two standards on BIM: NBR ISO 12006 and NBR 15965. The latter is the first Brazilian standard that addresses the Information Classification System, adapted from OMNICLASS.

Among the most well-known protocols internationally, we can mention here the BIM Project Execution Planning Guide, Version 2.2 that was produced by Pennsylvania State University in 2019 (Messner *et al.*, 2019). This guide was also the basis for the creation of the main Brazilian guides and guidelines. The BEP steps, described below, were based on this guide and adapted to the present work.

The BIM Execution Plan (BEP) consists of a manual that establishes the guidelines for the implementation of BIM in companies in the Architecture, Engineering, Construction and Operation (AECO) industry, in a planned and scaled manner, in order to achieve the defined objectives. The BEP should specify the entire scope necessary for implementation, identify the processes for each activity, define the exchange of information between stakeholders and describe the needs of the design project and infrastructure essential to provide adequate support to the implementation process.

The objective of the BEP should therefore be to effectively integrate BIM into the whole process of project deliveries, implementing it at a level that maximizes its value while reducing its costs and impacts, which can guarantee a greater efficiency in the implementation of BIM. The BEP starts with the diagnosis of the company and the design project for which it is intended to

start a pilot BIM project. In this phase, the following must be identified: the owner or person in charge of the project; the name of the design project; the address; brief description of the design; current diagnosis of the design process; number of disciplines to be developed, schedule and phases of the design. This information serves to build an initial diagnosis of the company in which the BEP manager will use as a basis to identify the profile of the company and the design project. After that, it is important to specify all deliveries that will be made, the design phases, the design disciplines and their respective documents. This information must be constructed for a specific design project and should not be applied to all design projects in a company (Messner et al., 2019).

The next step is to define the BIM objectives, which serve to determine the organization's interests in relation to BIM. In order to identify these objectives, the particular characteristics of the design, the skills of the team and the risks of the activities must be taken into account. BIM objectives need to be fully in line with the company's strategic planning to be implemented in accordance with the organization's BIM Mandate. The chosen objectives need to be measurable and aligned with the improvement of the company's planning, design, construction and operation processes (Messner et al., 2019). After these objectives, which are general to the organization, it is necessary to define the objectives of the design. These objectives are related to the specific design to which the BEP will be applied. It must consider the purpose of that design and what should be delivered and which Employers Information Requirements (EIR) should be supplied at the end of the process.

After defining the objectives and goals, it is important to translate them into the BIM Uses determined by the organization's requirements, in order to unravel them throughout the BEP. These have characteristics and specificities that will guide the entire implementation of BIM and must be defined together with a strategic management of the company. Specificities of BIM Uses are: identify potential BIM Model Uses; identify responsible parties for each BIM Use; needs assessment for those responsible for each BIM Use (resources, competence and experience); and determining when to implement each BIM Use.

After this initial process of diagnosis and definition of BIM Models Uses, a new process flow to be implemented in the company is analyzed and proposed. All this information is recorded and will be part of the BEP. This constitutes a base document for the formation of design contracts based on a BIM practice. It is from these steps proposed by Messner *et al.* (2019) that the implementation of the SINFRA BEP was conducted. Below are the steps that have already been taken to implement the BEP and the challenges that are yet to come.

3. Methods

The proposed method for the development of the BEP was the Design Science Research (DSR). This is a method for solving theoretical and practical design problems. The DSR aims to create and evaluate an artifact that allows satisfactory resolution to a practical problem (Lacerda, 2013). The Artifact in the case of this work is the BEP. For the structuring of this BEP the present research was based on the Project Execution Planning Guide, Version 2.2 (Messner *et al.*, 2019). From the phases proposed by this guide, the creation of the BEP was outlined. After the creation of the artifact, the next phase consists in the evaluation of the benefits for a SINFRA of the application of the BEP in the studied design. As a first stage for the constitution of the artifact, an immersion phase in the problem of the artifact was carried out. This was done through a bibliographic search in some of the main publications, Brazilian and international in BEP. Among the researched documents, Messner *et al.*, (2019), Eastman (2014), Succar (2009, 2016) and Leusin (2018) stand out.

Still in the Awareness stage, exploratory case studies have been carried out with market companies in order to analyze the use of the BIM Execution Plan in organizations. The Suggestion stage was made through joint meetings with Projects sector board for the development of SINFRA's objectives for BIM, in order to guide the entire construction of the BEP. As for the Development stage, the BEP processes are defined and elaborated. The evaluation stage took place partially, as the constructed artifact was validated by the SINFRA project team, but has not yet been tested in practice.

4. Results

As a starting point for the implementation of BIM at SINFRA, the work presented in this paper created a BEP for the design development of an architectural and complementary design. The BEP was built collaboratively with the design team in order to ensure its applicability, based on employee engagement with the proposal solution.

The initial results of the research demonstrate the importance, within a BIM implementation process, of the creation of the BEP. It also shows that the implementation of BIM can be unraveled in several stages, within a short, medium and long term schedule. For this, it is recommended to create several BEPs. Thus, it is possible to establish an implementation process with a more consistent evolution, supported by the reality of the company at that time. The first step in the implementation of BIM/BEP was to carry out a diagnosis at SINFRA. With this diagnosis, the need for a sector restructuring process, in line with the institution's strategic planning, was confirmed.

I. RODRIGUES, M. ANDRADE

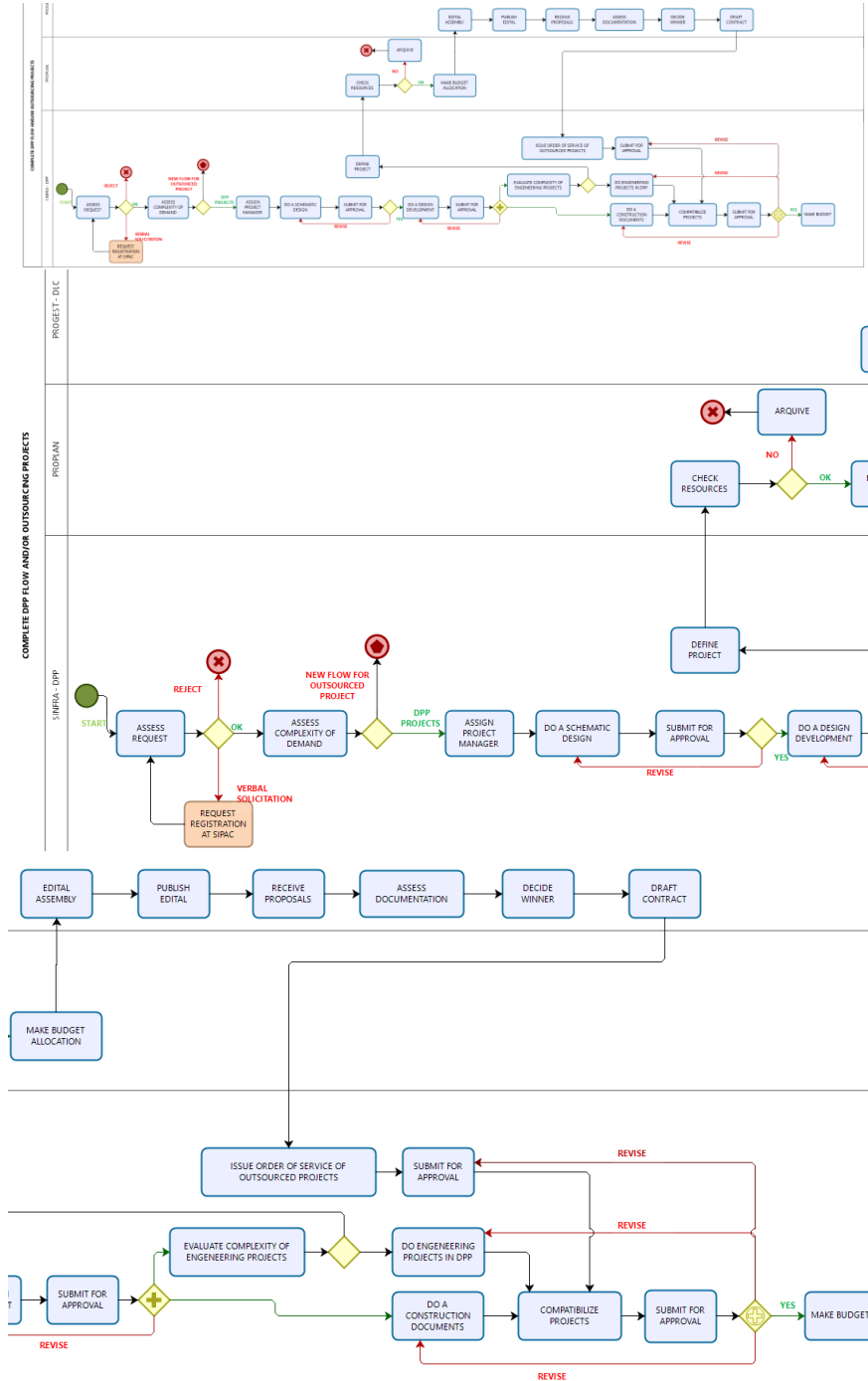

Figure 1: Current flow chart of SINFRA design process. Source: SINFRA internal production.

BIM EXECUTION PLAN (BEP) TO INFRASTRUCTURE SUPERINTENDENCE OF THE FEDERAL UNIVERSITY OF PERNAMBUCO

SINFRA is made up of five sectors, which have different but interconnected objectives and functions. For the initial stage of BIM implementation, the Plans and Design Sector was chosen. This is responsible for the development of design (architecture and complementary) and budgeting. The Design sector is composed of 22 people, 10 of whom are paid interns. Design subcontracting is decided according to the needs of each design project. It is based on the disciplines that the company has no specialist, as shown in the flow of projects in Figure 1.

SINFRA executes projects of very varied complexity, from simple maintenance of coating and painting to large educational centers within the university campus. This variation in the scale of the projects makes it necessary, when receiving a demand from a client - which may be the Rector or the Director of Institutes into the Campus - to assess the complexity of the order, in order to direct efforts to the internal team and/or hire an outsourced, see Figure 1.

To apply the BEP in the sector, a pilot project was chosen. The project consists in a building expansion of the UFPE Physics Department, with the construction of a small block of accessible toilets. For this work, it will be necessary to carry out architectural, hydro-sanitary, electrical, structural projects, in addition to budgets. Due to the size of the project, it was classified as low complexity and all projects were carried out by SINFRA internal team. The team assigned to the projects is composed by 02 architects, 01 electrical engineer, 01 hydro sanitary engineer, 01 budget engineer and 01 calculation engineer.

2.1. DESIGN OBJECTIVES

Based on the diagnostic interviews, it was possible to define the company's interests in relation to BIM, in order to leverage its internal processes. This has as essential objectives: (1) better collaboration between design teams and disciplines; (2) compatibility of design with the identification of possible clashes between disciplines; (3) improvement in the design's cost estimates with more accurate budgeting.

When analyzing the current design flow, it is noticed that the budget is built after the demand assessment, based on a basic design specification, and at the end, after the approval of the construction documents. Thus, between the initial cost estimate and the final budget, there may be a big difference, in financial terms, since the cost estimate only uses the design concept and the standard price reference table from UFPE as a basis.

With regard to collaboration, the design teams are assembled with two architects and a designer for each complementary discipline. As they are professionals of the SINFRA board, in theory it could be a positive point for

the existence of an effective collaboration. However, in practice, collaboration between design disciplines does not exist, or almost does not exist.

Complementary and structural design only enter the architecture flow after the construction documents design phase, and in many cases, there is no compatibility or revision. These happen only when required by the budgeting team. This late, not to say non-existent, clash process means that a lot of crucial information is not discussed in the preliminary study or in the preliminary design, and, when it occurs, only in the construction documents stage, causing rework and being able to influence the final cost of the design or the construction, since the design is in the final stages of detailing for delivery of the design for bidding and subsequent construction.

2.2. BIM USES

Table 1 presents the initial objectives of SINFRA for BIM and its BIM uses, specific to the implementation of a first pilot design project, already specified above. In the pilot design project, it was decided to separate the design flows from the Uses of the BIM Model defined in Table 1.

TABLE 1. BIM uses associated with the design objectives.

IMPORTANCE	GOALS OF THE PROJECT	BIM USES
HIGH	Improvement in cost estimation and quality of budget for construction	Cost estimation
HIGH	Improvement in project compatibilization	Clash detection
MEDIUM	Greater collaboration between the team and project disciplines	3D coordination

Source: Authors based on Succar (2018).

2.3. DESIGN FLOWCHART PROPOSED IN BEP

Based on the design's objectives, the institution's intention with BIM and the BIM uses, the design sector flowchart was redesigned. For this BEP, the proposal was the implementation of BIM in the design stage to finalize the architectural and complementary design development. In this context, the following flowcharts cover from the arrival of the demand until the completion of the architectural and complementary design development.

The proposal for the new flowchart (Figure 2) was to anticipate the entry of structural and installation design for the architectural design development stage. This decision was made based on the premises of BIM, which must anticipate possible errors in design in the various disciplines and adjust them in order to have a virtual model similar to the one executed in the work.

BIM EXECUTION PLAN (BEP) TO INFRASTRUCTURE SUPERINTENDENCE OF THE FEDERAL UNIVERSITY OF PERNAMBUCO

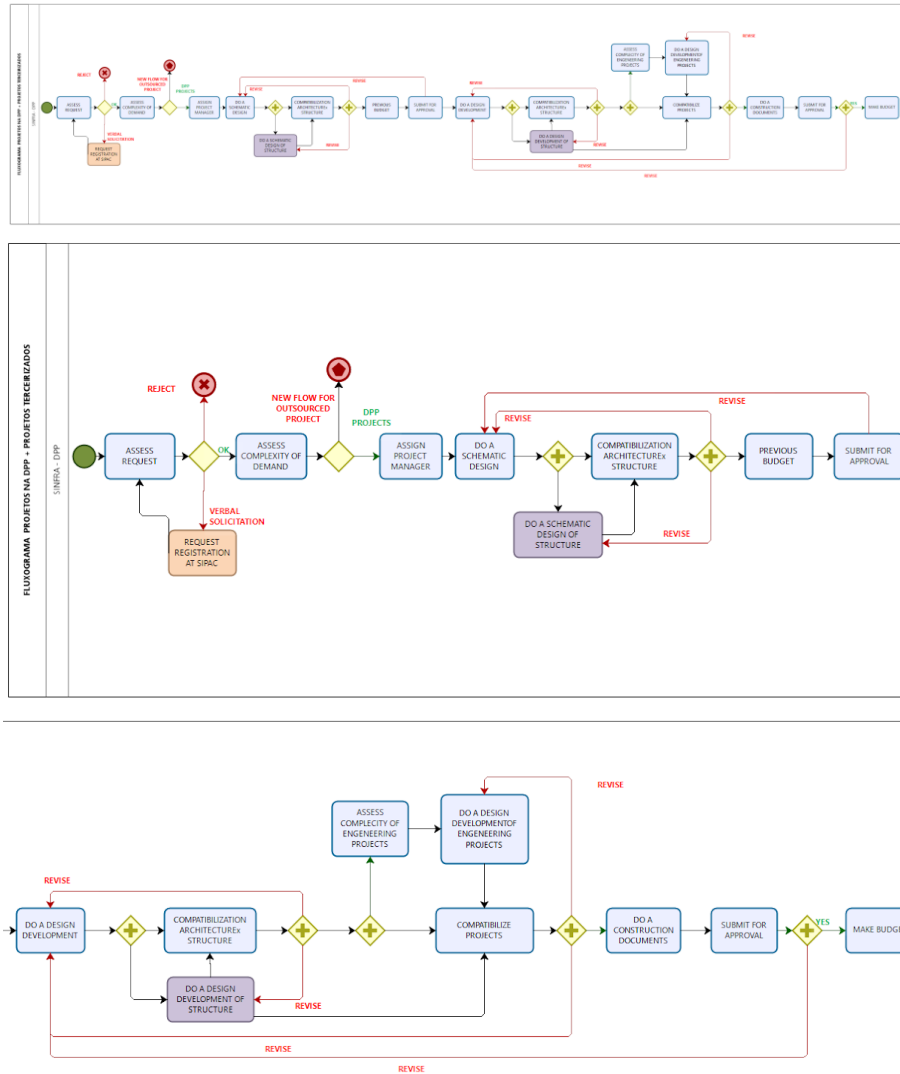

Figure 2: Design flowchart proposed up to the design development - SINFRA (revision 00). Source: Authors.

This helps to mitigate the recurring problem of collaboration and communication between disciplines at SINFRA. Therefore, in the preliminary study of architecture, the project is sent to the structural engineer and the preliminary study of the structure is received to be compatible with architecture (Figure 2). The schematic design of structure is a pre-

dimensioning and choice of the construction system, in order to assist the architectural design and the budget. After compatibility, the necessary adjustments are made in each design and it is advanced to carry out an estimate of the cost of the design, based on this model already reviewed. To conclude this step, the schematic design is submitted for approval and, if accepted, the schematic design architecture phase is passed.

In the design development phase, a new submission for the structure is carried out and made compatible with the structure design development phase received. Having carried out the revision based on compatibility, the architectural design is sent for the design of the complementary electrical and hydrosanitary development phase. A new stage of compatibility is made with the development phase of architecture, structure and complementary in order to eliminate the clashes and design inconsistencies. There is again a stage of presentation of the designs for approval and, then, the design development phases are sent to carry out the construction documents phases, with the creation of the respective documentation (plans, sections, facades, etc.).

It is also worth reiterating that the entire process of designing the flowchart was carried out in line with the design board members, as well as the team referring to the chosen pilot design project, through virtual presentation and discussion meetings. Such meetings generated the revision 01 present in this paper (Figure 3). After discussions with each of the team's designers and their deliverables, it became known that two complementary engineers develop their design by drawing it by hand, which would hinder the compatibility process proposed in the first flowchart (Figure 2).

Thus, revision 01 of the flowchart was proposed (Figure 3), in which the stage of complementary design development was added in software authored by a BIM intern and approved by the senior engineer, adapting to the need expressed by the team. It is also worth noting that it is not because there are steps that are not conceived in software authored by BIM that invalidates the BEP methodology and application (Sacks et al., 2018).

4. Final considerations

The development of the work is at the heart of the demand for the use of BIM to improve information management and increase collaborative work, especially within SINFRA. In addition to the previously mentioned BIM BR Strategy, the Government also aims to increase the BIM implementation in Brazil by 10 times, making 50% of civil construction GDP adopt BIM by 2024, when today only 9.2 % adopts, according to the survey by Fundação Getúlio Vargas (FGV IBRE). This confirms the need to invest in the proper implementation of methodologies that support BIM, in order to guarantee good results in its use.

BIM EXECUTION PLAN (BEP) TO INFRASTRUCTURE SUPERINTENDENCE OF THE FEDERAL UNIVERSITY OF PERNAMBUCO

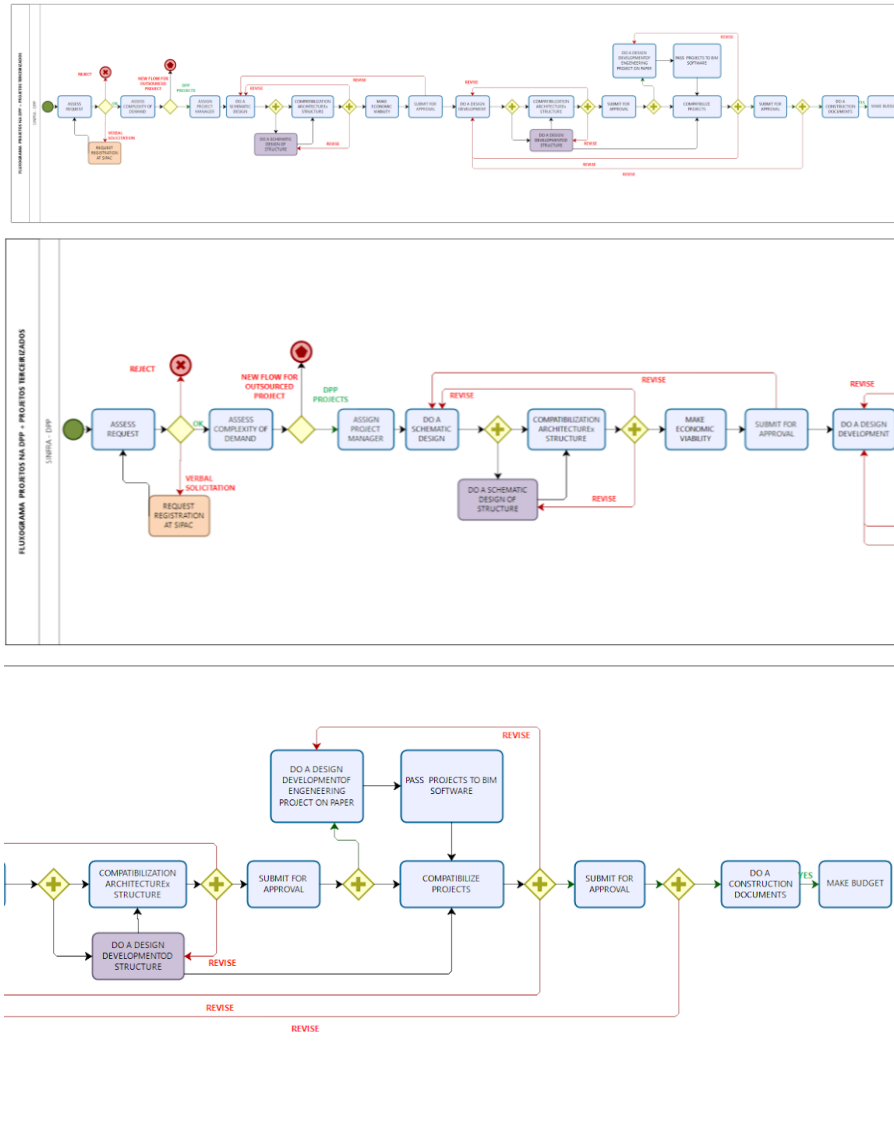

Figure 3: Design flowchart proposed up to the Design development - SINFRA (revision 01). Source: Authors.

The proposal to develop a BEP and its application allowed the deepening of theoretical knowledge, in addition to the application of that knowledge in an already consolidated, active design practice that presents a series of management deficiencies and collaborative practices. During the process of implementing the BEP, seeking to raise awareness among SINFRA design sector employees about the importance of adopting BIM and the need for structural changes for its proper implementation, the research faced the need

for changes in the proposed flows, adapting them to the local reality. This made it possible to improve the quality of the BEP, especially with regard to the adaptability of the employees' technical capabilities and the profile of the flow to be implemented.

Raising awareness of SINFRA's management and employees of the Plans and Design Directorate was another major challenge. Showing that the adoption of BIM involves not only the use of BIM tools and platforms, but a change in the way designers relate and exchange information was also another major challenge. More than simply using new tools, the proposal included making the team aware of the need to change the design culture, transforming the communication and collaboration processes. This was and still remains a major challenge for the Implementation of BIM and specifically the proposed BEP and partially presented in this paper. The next step, to be implemented in the coming months, is to assess the quality of the proposed BEP, identifying what has worked and what needs to be improved.

References

- ASSOCIAÇÃO BRASILEIRA DE NORMAS TÉCNICAS – ABNT. Construção de edificação: organização de informação da construção Parte 2 – Estrutura para classificação de informação. ABNT NBR ISO 12006-2, 2010.
- ASSOCIAÇÃO BRASILEIRA DE NORMAS TÉCNICAS – ABNT. Sistema de classificação da informação da construção. ABNT NBR 15965, 2011
- Brasil. Decreto nº 10.306, de 2 de abril de 2020(2020). Diário Oficial da União. Disponível em: http://www.planalto.gov.br/ccivil_03/_ato2019-2022/2020/decreto/D10306.htm
- EASTMAN, C. SACKS, R.; GHANG, L.; TEICHOLZ, Manual de BIM: um guia de modelagem da informação da construção para arquitetos, engenheiros, gerentes, construtores e incorporadores. 1º ed. Tradução: Cervantes Gonçalves Ayres Filho et al. Porto Alegre: Bookman.
- LACERDA, D., 2013. Design Science Research: método de pesquisa para a engenharia de produção (pp. 741-761). Gest. Prod., São Carlos.
- LEUSIN, S. (2018). Gerenciamento e Coordenação de Projetos BIM: Um guia de ferramentas e boas práticas para o sucesso de empreendimentos. 1. ed. Rio de Janeiro: Elsevier. ISBN 9788535290042.
- MESSNER, J., ANUMBA, C., DUBLER, C., GOODMAN, S., KASPRZAK, C., KREIDER, R., LEICHT, R., SALUJA, C., AND ZIKIC, N. (2019). BIM Project Execution Planning Guide, Version 2.2. Computer Integrated Construction Research Program, The Pennsylvania State University, University Park, PA, USA, August, Disponível em: <http://bim.psu.edu>.
- SACKS, R.; EASTMAN, C.; GHANG, L.; TEICHOLZ, P. BIM handbook: a guide to Building Information Modeling for owners, designers, contractors, and facility managers. Third edition. Hoboken, New Jersey: Wiley, 2018.
- SUCCAR, B. (2008) Building information modeling framework: a research and delivery foundation for industry stakeholders. Automation in Construction. Disponível em: <http://www.elsevier.com/locate/autcon>;
- SUCCAR, B. (2018) BIM adoption policies insights from across the World. ÉTS, Montreal. Disponível em: <http://gridd.etsmtl.ca/publications/atelier-bimcompetitivite-construction-2018/Succar%20-%20Macro%20BIM%20Adoption.pdf>;

D1.P1.S3

ARCHITECTONIC LANGUAGES II

ASSESSING THE EFFECTIVITY OF ADDITIVE MANUFACTURING TECHNIQUES FOR THE PRODUCTION OF BUILDING COMPONENTS

Implementing innovation for housing construction in Saudi Arabia

MOHAMMAD ALABBASI, HAN-MEI CHEN

University of Liverpool

Email address: m.alabassi@liverpool.ac.uk

Email address: hanmei.chen@liverpool.ac.uk

AND

ASTERIOS AGKATHIDIS

Email address: asterios.agkathidis@liverpool.ac.uk

Abstract. This paper examines the suitability of existing robotic technologies and large-scale 3D printing techniques for the fabrication of three-dimensional printed building components to be applied in the Saudi housing construction industry. The paper assesses a series of cases based on the applications for 3D-printing cement-based materials in construction. In particular, we investigate five different additive manufacturing techniques and evaluate their performance in terms of their flexibility/mechanism, control/navigation, calibration/operation system, fabrication suitability (in-situ or off-site), size of printed components, printing speed. The findings include in a matrix chart, where the advantages and disadvantages of each technique become evident. The paper further evaluates the suitability of each technique in relation to the particular climatical and socio-political context of Saudi Arabia, applicable to other construction industries with similar conditions.

Keywords: *Building Technologies; Additive Manufacturing of Concrete; Housing Construction; 3D Printing.*

ملخص. الدراسة تحلل ملاءمة تقنيات الطباعة الثلاثية الأبعاد للمباني لاستخدامها في إنشاء المباني السكنية بالمملكة العربية السعودية. تم إجراء الدراسة بناءً على تقييم وتحليل لأفضل ممارسات الطباعة ثلاثية الأبعاد التي تستخدم مادة الخرسانة بشكل أساسي في عملية الطباعة. تحديداً، تم تحليل خمس تقنيات طباعة ثلاثية أبعاد وتقييم أداءها بناءً على هذه

ASSESSING THE EFFECTIVITY OF ADDITIVE MANUFACTURING TECHNIQUES FOR THE PRODUCTION OF BUILDING COMPONENTS

المعايير: المدى الحركي لأداة الطباعة، وكيفية التحكم، و معايرة نظام التشغيل، وسهولة الاستخدام في موقع البناء، و حجم العنصر المطبوع، وسرعة الطباعة. تم تلخيص مخرجات الورقة في جدول يقارن أهم المميزات والتحديات لكل تقنية على حدٍ. المخرج النهائي من هذه الورقة سيساهم في تقديم نظرة شاملة لمدى إمكانية استخدام تقنيات الطباعة الثلاثية الأبعاد في المملكة، مع الأخذ في الاعتبار الأجواء المناخية الحارة والجهود الحكومية لتطوير قطاع الإسكان ضمن رؤية المملكة 2030، علماً أنه من الممكن الاستفادة من مخرجات هذه الدراسة في أسواق بناء أخرى مماثلة للمملكة من حيث الدعم الحكومي والأجواء المناخية.

الكلمات المفتاحية: الطباعة الثلاثية الأبعاد للمباني- صناعة البناء- الإسكان- تقنيات البناء.

1. Introduction

The discovery of oil in 1938 was a significant catalyst for transforming the Kingdom of Saudi Arabia. In the 1970s, the massive profits from selling oil enabled the government to subsidise the development of infrastructure throughout several industries, including electricity, transportation, telecommunication and water. Later, the subsidisation expanded towards other essential sectors in the country such as education, health and wellness, military, and the creation of petroleum-based industry. Accordingly, the construction industry started to play a vital role in contributing to the country's rapid development and is currently the second biggest industry, aside from the oil.

In 2016, Saudi Arabia launched an economic and socio-political restructuring plan in 2016 under the title 'Vision 2030' (Government of Saudi Arabia, 2016). The future vision aims to diversify the Saudi economy and society by modernising the country and ending its long-term dependency on oil. The distinct socio-economic challenges include the rapid population growth of 2%, unemployed citizens, and the decrease of global demand on oil (Roll, 2019). The Ministry of Housing has stated that there is an urgent need to build millions of residential units within five years aiming to match the Vision 2030 target of an increase in homeownership from 24% to 52% by 2030 (Saudi Ministry of Housing, 2016).

Besides, governmental decision-makers have started exploring a new strategic plan to meet high housing demand. Part of this plan is focusing on novel construction technologies. Hence, the Ministry of Housing has started an initiative called 'Building Technology Stimulus Initiative (BTSI)'. BTSI aims to transform the construction market by utilising a feasible, intelligent, and sustainable building system. It also seeks to cope with the Fourth Industrial Revolution by attracting the best practice of additive manufacturing and robotic technologies in the market through a subsidisation programme. Thus, it is essential to explore the best practice of existing construction technologies and then assess their suitability to be implemented within the Kingdom's current construction standards. To the

best of our knowledge, the results of implementing these technologies in the Saudi construction market has not been evaluated to be implemented based on the Saudi Building Code.

Furthermore, after studying the different factors of which the Saudi housing crisis is composed of, it became evident that the construction sector lacks productivity, is short of labour, and the average construction quality is relatively low. This indicates that the current construction typology and method of load-bearing, in situ, reinforced concrete frame, is inefficient to meet the aim of the Saudi Vision 2030 (Theodore Karasik, 2017). It is linked to high material waste, is very time-consuming, and requires intensive labour.

Another vital issue is the deficiency of industrial standardisation for housing construction. Precast construction is applied for commercial projects mostly. Most of the existing precast facilities are dedicated to the construction of megaprojects. Besides, precast components are lacking customisation, which makes them being disregarded by the local citizens. Besides, the cost of creating precast moulds, for mass customisation propose, in addition to the high transportation cost, makes prefabricated houses unaffordable. The average Saudi home buyers prefer to live in a customised house, based on their individual needs.

Finally, the labour force shortage is another significant impact factor to the country's construction industry, causing construction delays, a challenge identified by different Saudi researchers (Alqahtany and Mohanna, 2019). Indeed, foreign construction workers represent the majority in the housing construction industry. In 2017, about 796,000 ex-pat workers left the Saudi labour market, 221,000 of them left during the first quarter (Bridge, 2018).

Consequently, we are looking for additive manufacturing techniques able to operate with reinforced concrete as specified by the Saudi Code of Construction (SBC 304), are easy to transport, can operate in small construction sites, can be protected by the harsh weather conditions, e.g. by being contained indoors and are reliable in their performance, quality and fabrication speed.

We believe that construction time, cost, and quality can be improved by integrating robotic fabrication in the construction process. Our research focuses on the use of robotics and additive manufacturing technologies in comparison to conventional methods using formwork to cast the reinforced concrete. We aim to highlight potential solutions for Saudi Arabia's housing construction industry by conducting comparative analysis and assessing the suitability of currently available methods and techniques of 3D printing and additive manufacturing technologies for the Saudi construction market. Thus, the following research questions will be addressed:

- What large-scale additive manufacturing technologies are available, and how can they be used in housing construction?

ASSESSING THE EFFECTIVITY OF ADDITIVE MANUFACTURING TECHNIQUES FOR THE PRODUCTION OF BUILDING COMPONENTS

- What is the most effective way of implementing additive manufacturing technology in housing construction?
- What construction materials and restrictions must be taken into account to achieve an appropriate design within the Saudi climatic/socio-political context?

2. Methodology

To answer our research questions, we will analyse seven distinctive case studies to provide a comprehensive overview of existing additive manufacturing/3D printing processes in the construction industry and examine their suitability for the Saudi context. All case studies explore different tools and techniques. However, they all share the same principle of implementing additive manufacturing to fabricate large-scale building components. The selection of the following additive manufacturing techniques is based on cementation-based extrusion.

In particular, we have categorised the selected case studies based on their additive manufacturing technique and applied technology in the following categories: (1) mobile robotic arm 3D printing; (2) static robotic arm 3D printing system; (3) gantry-based 3D printing system; (4) customised robotic printing (5); and swarm robotic 3D printing.

We will then conduct a comparative analysis of this case studies focusing on the following evaluation criteria: (a) flexibility/ mechanism, (b) control/ navigation, (c) calibration/operation system, (d) fabrication suitability (in-situ or off-site), (e) size of printed components, (f) printing speed.

Indicating the key challenges influencing each type of classified techniques is one of the key findings in this paper. An insightful discussion of the presented case studies will be provided through exploring issues affecting the practical use of 3D printing in-situ and in-factory.

We aim to provide a guideline for the possible challenges when it comes to practice by presenting the advantages/disadvantages of each 3D printing technique examined here. These critical findings are summarised in a matrix, offered to help future research by providing essential criteria to evaluate each technology. The paper concludes with the effectiveness of concrete 3D printing technology and the role it could play in the Saudi Housing Vision 2030 as well as to inspire future research in this field.

3. Case Studies

3.1. CASE STUDY 1: 3D STUDIO 2030 BY CYBE IN SAUDI ARABIA

This case study demonstrates the process of in-situ 3D printed concrete components using a mobile robotic arm, which was installed on a caterpillar. The fabrication was performed in a controlled environment. The 48 printed components consist of 27 walls and 21 parapets. Steel reinforcement grouted manually to the printed elements (

Figure 1). The construction of the project was completed within one week, which became a showcase for several 3D printed houses as set by the Saudi Ministry of Housing.



Figure 1. Showcase for Studio 2030 by CyBe in Saudi Arabia

3.2. CASE STUDY 2: DUBAI MUNICIPALITY BUILDING BY APIS COR

This case study verifies the applicability of implementing in-situ concrete 3D printing using a developed 3D concrete printing robot. However, the steel reinforcement has been embedded conventionally (

Figure 2). This building is considered to be the largest 3D printed building in the world. The building contains two floors, the area of which is 640 square meters, with a total height of 9.5 meters (Block, 2019). This case study has proved the productivity of additive manufacturing technology to be implemented in an arid climate without any insulation for the printing robot.

ASSESSING THE EFFECTIVITY OF ADDITIVE MANUFACTURING TECHNIQUES FOR THE PRODUCTION OF BUILDING COMPONENTS



Figure 2. One can see reinforcement embedded conventionally in Dubai Municipality Building

3.3. CASE STUDY 3: APARTMENTS BUILDING IN SHANGHAI WINSUN COMPANY

This case study presents a 6-story building, which was 3D printed using a gantry-based system. It is considered to be the tallest 3D printed concrete building. The Chinese based company used recycled construction waste as a filament, which was extruded by a 150 meters long printer (*Figure 3*) (Perry, 2015). The utilisation of the gantry-based system is like a production line in a factory. The gantry printer can move in three-axis.



Figure 3. Winsun 6-Story tall 3D printed building

3.4. CASE STUDY 4: THE BOD BY COBOD IN COPENHAGEN

This case study presents the first 3D-printed building in Europe. The name BOD refers to “Building on Demand”. This building is a small office unit, built on 50 square meters in Copenhagen (

Figure 4) (3Dprinthuset.dk, 2017). The aim of constructing this building is to prove that 3D printing technology can be applied in line with the Danish Construction Code. The size of the gantry printer used in this experiment is 8 m × 8 m × 6 m, it can print a component with a thickness 20mm and width of 50-70 mm for each layer, with a speed of 2.5 meters/minute. The used concrete was made out of recycled tiles and sand.



Figure 4. First 3D concrete printed building in Europe by COBOD

3.5. CASE STUDY 5: CONPRINT3D BY TU DRESDEN

This case study presents a novel approach of using a mobile concrete pump as a 3D concrete printer for in-situ construction (*Figure 5*). Researchers in this project have explored a similar concrete 3D printing approach exploring both for in-site and off-site fabrication. They distinguished their unique method from others by developing the CONPrint3D printing nozzle for conventional construction with leaner walls and sharp corners. This approach is making the most of the available equipment by upgrading mobile concrete pumps to 3D printers, which means the cost of the concrete 3D printer could be decreased. The upgraded machinery can work with the existing, standard concrete composition, with a maximum aggregate size of 8mm, that can be used with the developed printing-head without affecting the concrete flow. The CONPrint3D printing nozzle can make surfaces with precise quality and tolerances (Mechtcherine et al., 2019). The printer was tested in a controlled environment to fabricate a floor of approximately 130 square meters, with a printing speed of 150 mm/s, and the height of the printed layer is 5 mm.

ASSESSING THE EFFECTIVITY OF ADDITIVE MANUFACTURING TECHNIQUES FOR THE PRODUCTION OF BUILDING COMPONENTS



Figure 5. A mobile concrete pump used as a concrete 3D printer

3.6. CASE STUDY 6: LARGE-SCALE 3D PRINTING BY A TEAM OF MOBILE ROBOTS BY THE SINGAPORE CENTRE FOR 3D PRINTING

This case study describes a 3D printed wall by two mobile robots, which were programmed to work collaboratively (*Figure 6*). This was made possible through Simultaneous Localisation and Mapping (SLAM) and motion planning (Zhang et al., 2018). The advantage of SLAM-based navigation and motion planning is the robots can configure their surrounding environment, by moving around with an attached camera and sensor. They can draw a map for the site as well as avoid any site collision between them (Cadena et al., 2016).



Figure 6. Swarm robotic experiment by the Singapore Centre for 3D Printing

3.7. CASE STUDY 7: MINIBUILDERS BY IAAC

The MiniBuilders project offers another method of concrete 3D printing with the use of three miniature robots with a different degree of mobility within the system (

Figure 7). The robots were programmed via a multi-agent system. Each robot has a specific functionality. Following a pre-designed path, the first robot prints a concrete foundation with the use of a sensor (IAAC, 2013). By positioning itself on the foundation, the second robot securely holds onto the foundation with rollers and can print the walls by layers of concrete. The final robot prints the finishing vertically onto the structure with the use of suction cups and pressured air, adding reinforcement to the printed structure.

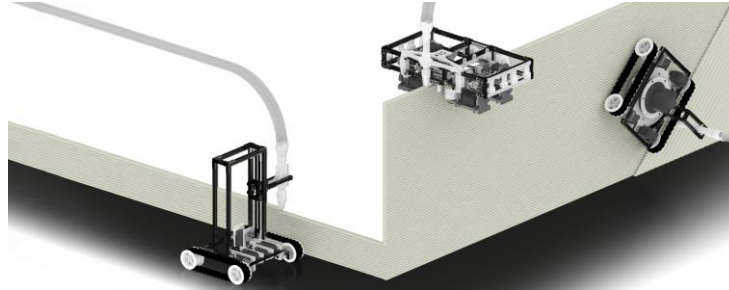

Figure 7. MiniBuilders developed by IAAC

4. Findings

After analysing the case studies mentioned above, we will now proceed to the comparison based on the following criteria: (a) flexibility/ mechanism, (b) control/ navigation, (c) calibration/operation system, (d) fabrication suitability (in-situ or off-site), (e) size of printed components, and (f) printing speed.

Studio 2030's case study 1 is not just demonstrating the ability to implement concrete 3D printing for in-situ construction but contains other knowhow on the installation of other building components such as the floor tiles, a prefabricated roof, the windows, the mechanical and electrical system, the plumping as well as about providing thermal comfort with good indoor air quality. The operation of the printing process requires advance training for the operators.

The implementation of the Dubai Municipality building mentioned in case study 2 has proved its suitability for in-situ 3D printing in an arid climate without providing a controlled environment for the robotic-printer. However, the printing was performed during the winter season. It is vital to conduct further investigation, especially during the summer, to validate its suitability for a warmer climate.

Overall, mobile and static robotic arms are similar in terms of extruding material, calibration and printing time. Both of which are capable of printing in 3-axis, 4-axis, 5-axis, 6-axis, and 7-axis. They can 3D print various materials, such as concrete, plastic, or steel. However, when it comes to flexible mobility and the size/length of printed components, mobile robotic systems are clearly in the advantage.

Three-dimensional printing has proved its efficiency to construct multi-story buildings as presented in the apartment building in Shanghai by the Winsun company in case study 3. Winsun has successfully developed the refinement of vernacular building construction. However, studying the

ASSESSING THE EFFECTIVITY OF ADDITIVE MANUFACTURING TECHNIQUES FOR THE PRODUCTION OF BUILDING COMPONENTS

building's life cycle is vital, as there is no sufficient consideration for the long-term assessment.

Furthermore, the experiment conducted by the Danish company COBOD demonstrated in case study 4 has proven its capability to 3D printing curved buildings. It also proved its efficiency to construct buildings in a shorter time, with less workforce, with the use of environmentally friendly materials as well as its ability to minimise construction waste, which represents approximately 2 million tons annually in Denmark (3Dprinthuset.dk, 2017). Correspondingly, the showcase fulfils EU Construction Standards for 3D printing and automation in construction. The experiment does not address the obstacles of 3D printing concrete in-situ, nor a benchmark for the cost-efficiency of printing conventional walls versus curvature walls.

Without a doubt, the gantry-based system has the advantage of printing the whole building in one go. Nevertheless, the limitations of the printer size have a significant effect on architectural design. In other words, the floor area and the height of the building should fit with the printer size. However, the calibration of the gantry-based system is easier than the mobile or static robot due to the limitations of movement in just 3-axis XYZ.

Transforming an existing mobile concrete pump into a 3D printer for in-situ construction will increase the future utilisation of additive manufacturing technologies in construction. The digital chain demonstrated in case study 5 by CONPrint has a promising future for the design-to-fabrication approach. Although the innovative CONPrint3D nozzle was tested to 3D print a floor of a house, the experiment conducted in a lab environment, it will be a challenge to migrate the proposed technology to a construction site without considering climatic, architectural, and engineering factors. It is essential to examine the entire proposed system, transformed mobile concrete pump and the nozzle, in a construction site. The site experiments should include structural analysis of the proposed construction system.

The combination of different disruptive technologies such as artificial intelligence, mechatronics, and architecture will significantly transform the construction industry in the near future. In case study 6 and 7, the concept of utilising swarm robotics opens new opportunities for the construction industry by implementing new, multidisciplinary technologies. Although the swarm robotics technology in case study 6 has proven its ability to print a component in a short time, further investigation regarding the component's structural performance is needed. As shown in Figure 6, the two robots successfully printed a concrete structure, but a clear segregation line appeared. The joints between the printed components need to be examined. Furthermore, the calibration and implementation of swarm robotics require advanced programming skills.

The findings of our comparative analysis have been summarised in the chart illustrated in *Figure 8*, which highlights the different robotic/additive manufacturing technologies and their properties/possibilities.





Parameters	1. Mobile Robotic Arm	2. Static Robotic Arm	3. Gantry-Based System		4. Customised Robotic	5. Swarm Robotic	
System illustration							
Project	case study 1 3D STUDIO 2030	case study 2 DUBAI MUNICIPALITY	case study 3 APARTMENTS BUILDING IN SHANGHAI	case study 4 THE BOD	case study 5 CONPRINT3D	case study 6 LARGE-SCALE 3D PRINTING BY A TEAM OF MOBILE ROBOTS	case study 7 MINIBUILDERS
Research Lab/ Company	CyBe construction company	Apis Cor	Winsun Company	COBOD company	TU Dresden	Singapore Centre for 3D Printing	IAAC
Flexibility/ Mechanism	6 axis robotic arm positioned on a caterpillar	3-axis (Apis Cor), and can be 4-5-6 or 7-axis	4 axis		Mobile concrete pump	Two medium-size mobile robotic arms	Three small-size swarm robots developed by IAAC
Control/ Navigation	Manipulator and motion sensor	Manipulator and motion sensor	Toolpath based on a slicer software		(N/A)	Sensor and camera using machine learning	1st robot has a sensor follows a designated path on the ground; 2nd robot climbs and rolls on the printed foundation; 3rd robot has a vacuum generator
Calibration/ Operation system	Firmware used to control robotic arms; the robotic arm has a motion sensor or a camera to perform an accurate movement for a dedicated task given through G-code		The gantry-based system is similar to a production line based-system, the instructions is given through G-code generated from a slicing software		Digital process chain starts with a BIM geometry model	Simultaneous Localization and Mapping (SLAM) and motion planning	Multi-agent system
Fabrication suitability (in-situ or off-site)	in-situ fabrication	in-situ fabrication	off-situ and in-situ fabrication	in-situ	In-situ, but the experiment for printing a floor plan was conducted in lab	In-lab fabrication	In-situ fabrication using three mini-robots collaboratively
Size of printed components	Layer height is 30 mm; printing rang up to 2.75 m; and a maximum height of 4.5 m	(N/A)	(N/A)	The largest gantry size is (L 40 x W 10 x H 6.6 m)	130 m ² within one day; layer height 5mm	Medium-scale 3D printed concrete pattern (1.86 x 0.46 x 0.13 m)	1.5m high at the Design Museum of Barcelona (Dhub)
Printing speed	200 mm/s	(N/A)	(N/A)	Max 100 cm/sec ; Average 40-50 cm/sec	150 mm/s	7 min 50 s for (1.86 x 0.46 x 0.13 m) in	(N/A)

Figure 8. Categorisation and analysis of different existing additive manufacturing techniques

5. Conclusion

Based on the comparative analysis matrix shown in *Figure 8*, it becomes evident that mobile and static robotic arm technology can become an ultimate game-changer for the construction industry in Saudi Arabia. Overall, printing building components with robotics-based printers

ASSESSING THE EFFECTIVITY OF ADDITIVE MANUFACTURING TECHNIQUES FOR THE PRODUCTION OF BUILDING COMPONENTS

will not only increase the production efficiency of construction, but it will also attempt to overcome the customisation challenge necessitated for individuals in Saudi Arabia, which the centralised precast manufacturing failed to achieve. Admittedly, there are several challenges related to implementing robotic printing in the construction sector. In this paper, the most obvious challenge is operating robotics for in-situ fabrication. It would be difficult to manage the printing of the housing components during summer season without working in a controlled environment due to the high temperature and dust, which are very typical in Saudi Arabia. Moreover, the properties of the printing materials will significantly affect the architectural design. However, these challenges will pave the way for a novel construction system which could be embedded within the current Saudi Building Code.

In that context, we are proposing a mobile mini-factory fabrication unit which will be developed further in the next phases of our research (*Figure 9*). The inspiration of the mobile printing unit came from the R-O-B unit developed by Gramazio and Kohler in 2008 for bricks laying (Gramazio Kohler Research, 2008). Our system will be utilised in a shipping container as a mini-factory unit for in-situ fabrication. This mobile unit aims to solve the issues mentioned at the beginning of this paper by mitigating the transportation cost, reducing labour in the construction site, and increasing the production quality and efficiency. The proposed file to factory workflow is based on algorithm-aided design, allowing users to adjust the required parameters based on their individual needs. The final design can be converted into Gcode as a tool path for the robotic arm, starting with the building layout. This approach offers the integration of design and fabrication into one single process.

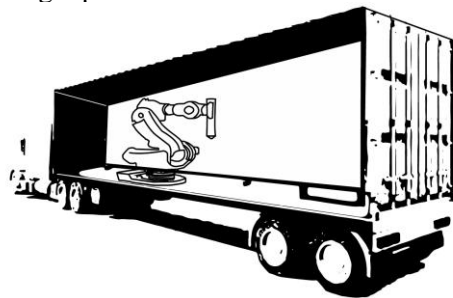

Figure 9. Mobile mini factory unit in a shipping container

References

- 3Dprinthuset.dk, 2017. A small office hotel in Copenhagen's Nordhavn [WWW Document].
3dprinthuset.dk. URL <https://3dprinthuset.dk/europes-first-3d-printed-building/>
(accessed 2.26.20).

- ALQAHTANY, A., MOHANNA, A. Bin, 2019. Housing challenges in Saudi Arabia : the shortage of suitable housing units for various socio-economic segments of Saudi society 22, 162–178. <https://doi.org/10.1108/HCS-01-2019-0002>
- BLOCK, I., 2019. Apis Cor builds world’s largest 3D-printed building in Dubai [WWW Document]. URL <https://www.dezeen.com/2019/12/22/apis-cor-worlds-largest-3d-printed-building-dubai/> (accessed 2.20.20).
- BRIDGE, S., 2018. Saudi Construction Sector Hardest Hit by Expat Exodus [WWW Document]. ArabianBusiness.com.
- CADENA, C., CARLONE, L., CARRILLO, H., LATIF, Y., SCARAMUZZA, D., REID, I.D., LEONARD, J.J., 2016. Simultaneous Localisation And Mapping : Present , Future , and the Robust-Perception Age 32, 1–29. <https://doi.org/10.1109/TRO.2016.2624754>
- GOVERNMENT OF SAUDI ARABIA, 2016. Vison 2030 Kingdom of Saudi Arabia, Report. Government of Saudi Arabia.
- GRAMAZIO KOHLER RESEARCH, 2008. Gramazio Kohler Research [WWW Document]. URL <https://gramaziokohler.arch.ethz.ch/web/e/projekte/135.html> (accessed 10.26.20).
- IAAC, 2013. Minibuilders [WWW Document]. URL <https://iaac.net/research-projects/large-scale-3d-printing/minibuilders/> (accessed 9.25.18).
- MECHTCHERINE, V., NERELLA, V.N., WILL, F., NÄTHER, M., OTTO, J., KRAUSE, M., 2019. Large-scale digital concrete construction – CONPrint3D concept for on-site, monolithic 3D-printing. Autom. Constr. 107, 102933. <https://doi.org/10.1016/j.autcon.2019.102933>
- PERRY, F., 2015. Chinese firm creates “world’s tallest 3D-printed building” | Cities | The Guardian [WWW Document]. Guard. URL <https://www.theguardian.com/cities/2015/jan/31/chinese-firm-creates-worlds-tallest-3d-printed-building> (accessed 2.20.20).
- ROLL, S., 2019. Economic Reforms and Power Consolidation in Saudi Arabia. A Sover. Wealth Fund Switz. <https://doi.org/10.2139/ssrn.2991115>
- SAUDI MINISTRY OF HOUSING, 2016. The Housing Program Delivery Plan. Government of Saudi Arabia.
- THEODORE KARASIK, 2017. Saudi Housing Requirements for a Strong and Secure Future [WWW Document]. Int. Policy Dig. URL <https://intpolicydigest.org/2017/06/09/saudi-housing-requirements-strong-secure-future/>
- WEATHER-ATLAS.COM, 2019. Riyadh, Saudi Arabia - Detailed climate information and monthly weather forecast [WWW Document]. URL <https://www.weather-atlas.com/en/saudi-arabia/riyadh-climate#temperature> (accessed 3.13.20).
- ZHANG, X., LI, M., LIM, J.H., WENG, Y., TAY, Y.W.D., PHAM, H., PHAM, Q.C., 2018. Large-scale 3D printing by a team of mobile robots. Autom. Constr. 95, 98–106. <https://doi.org/10.1016/j.autcon.2018.08.004>

A NEW PARADIGM IN GENERATIVE DESIGN LINKING PARAMETRIC ARCHITECTURE AND MUSIC TO FORM FINDING

EHSAN RONAGH, MOHAMMADJAVAD MAHDAVINEJAD
Faculty of engineering, Islamic Azad University, Karaj, Iran.
Email address: e.ronagh@gmail.com
Department of Architecture, Tarbiat Modares University, Tehran,
Iran.
Email address: mahdavinejad@modares.ac.ir

AND

ANOOSHA KIA
Faculty of engineering, Islamic Azad University, Karaj, Iran.
Email address: kia.anoosha@gmail.com

Abstract. In recent years, geometry and innovations have become an important topic in contemporary architecture. In addition, the 21st century is considered as a new era in architectural design. Computer software development has introduced the theory of form-finding. The present study proposes a novel design and construction method in form-finding based on the relationship between parametric architecture and music. To achieve this goal, several algorithms were designed. The simulation was performed in Rhino with Grasshopper and Firefly plugins, and extensive prototyping of the shells was performed at High-performance Architecture Lab (HAL). This study is aimed at presenting a new design and construction method as a generative design that can use two main characteristics of sound namely frequency and intensity over time. The design also forms the numerical outputs of the music to deform the modular two-dimensional geometric patterns and transform them into three-dimensional parametric shells. The resulting research is fully applicable at a large scale such as urban landscape and small scale as interior design.

Keywords. *Parametric architecture, Music, Mathematics, Geometry, Algorithm.*

ملخص. في السنوات الأخيرة ، أصبحت الهندسة والابتكارات موضوعًا مهمًا في العمارة المعاصرة. بالإضافة إلى ذلك ، يعتبر القرن الحادي والعشرون حقبة جديدة في التصميم

المعماري. لقد أدخل تطوير برامج الكمبيوتر نظرية إيجاد النموذج. تقترح الدراسة الحالية طريقة تصميم وبناء جديدة في اكتشاف النموذج بناءً على العلاقة بين العمارة البارامترية والموسيقى. لتحقيق هذا الهدف، تم تصميم عدة خوارزميات. تم إجراء المحاكاة في Rhino مع إضافات Grasshopper و Firefly، وتم إجراء نماذج أولية شاملة للقذائف في مختبر الهندسة المعمارية عالي الأداء (HAL). تهدف هذه الدراسة إلى تقديم تصميم جديد وطريقة بناء كتصميم توليدي يمكنه استخدام خاصيتين رئيسيتين للصوت وهما التردد والشدة بمرور الوقت. يشكل التصميم أيضًا المخرجات العددية للموسيقى لتتنويه الأنماط الهندسية المعيارية ثنائية الأبعاد وتحويلها إلى قذائف بارامترية ثلاثية الأبعاد. البحث الناتج قابل للتطبيق بالكامل على نطاق واسع مثل المناظر الطبيعية الحضرية والمقياس الصغير مثل التصميم الداخلي.

الكلمات المفتاحية: العمارة البارامترية، الموسيقى، الرياضيات، الهندسة، الخوارزمية.

1.Introduction

Goethe: “Music is liquid architecture; Architecture is frozen music.” Since architecture involves designing, it always includes creativity. Thus, it requires up-to-date technology and knowledge to realize and build innovative designs. It can be a creative and applied method to express a new design approach. This can be done with the help of day knowledge and tools in the context of form-finding in architecture based on a specific theoretical framework with a comprehensive application on a large scale such as urban landscape or a small scale such as details in the interior design.

Architects often employ design methods to find creative forms (Jormakka, 2009). Contemporary architecture should discover the hidden potential of traditional architecture and use new technologies and strategies to create a novel architectural identity for the future (Amini, Mahdavinejad and Bemanian, 2009).

By establishing an approach to architecture, that includes our current tools, we can gain a new understanding of existing architectural knowledge. At the same time, we can open up new opportunities in architectural thinking through applying emerging insights from other fields and disciplines (Werner, 2011).

Architects who apply their generative modeling and scripting skills for creating virtual and prototypical spaces using algorithms and bespoke coding increasingly find real world applications for their works. Nowadays, architects can solve industrial and infrastructural problems with new ideas and emerging building types that have shaped urban and peripheral environments (Werner, 2015).

Digital architecture, developed in the 1960s and supported by CAAD in the 1990s, has created the path towards an architecture produced by computer and architect through a mutual relationship. The evolution of architecture since the 1970s has led to the beginning of the first digital wave in the 1990s, and subsequently to the emergence of new typologies of buildings, architects and design tools (Werner, 2019).

A NEW PARADIGM IN GENERATIVE DESIGN LINKING PARAMETRIC ARCHITECTURE AND MUSIC TO FORM FINDING

Today, design and construction tools are rapidly eliminating designers' constraints in all areas. Parametric architecture has opened a new window for designers to introduce novel and modern designs and construction methods. It is a style with distinctive features that uses mathematics, geometry, and designing and construction tools and technologies.

Parametric architecture is a process based on algorithmic thinking, which defines the relationships of a set of parameters based on specific rules to achieve a certain goal. Parametric design is a design paradigm in which the relationships between the elements shape the geometry propagation and complex forms. Parametric design is not a new idea and it has shaped architecture and design partially over its long history. One of the earliest examples of parametric design is the reversed model of churches by Antoni Gaudi or the Munich Olympic design by Frei Otto.

In the field of music, one can say that music is formed based on specific notes and has a specific grammar that is associated with acoustic oscillations.

In this research, we sought to introduce and describe a new design method for new forms in architecture based on establishing a mathematical and geometrical relationship between parametric architecture and music.

2.Literature Review

Numerous studies have been done on the relationship between architecture and music, including examining this relationship with a conceptual approach. Some common factors have been used in this area such as rhythm, accent, theme, harmony, color, symmetry proportion, etc. These are the principles and tools for converting music works into architecture and vice versa. However, this method lacks a clear theoretical framework, so that based on which, any music could have a particular output. Therefore, the designer designs based on his inference of that music and its characteristics.

On the other hand, there are studies on the relationship between architecture and music based on form and sound physics, which are highly applied works. Some of the outputs from these studies were used as a basis for our research process. A summary of these studies is given in the following table (Table 1).

TABLE 1. Basic studies in the context of examining the formal relationship between architecture and music

Previous studies on the relationship between Music and Architecture with a formal approach		
Reasercher	Perspective / Performance	Reference
Pythagoras Plato	The relationship between mathematics, geometry, music and architecture, and the expression of harmonious cosmic ratios	(Antoniades, 2012)
Greeks	Geometry music returned to sound	(Ching, 2007)
Adonis Georgiades	Visual or audio harmony guarantees aesthetic pleasure	(Antoniades, 2012)
Bela Bartok	The use of Pythagorean golden ratios in music	(Antoniades, 2012)
Iannis Xnakis	Emphasis on the science of geometry as a factor of adaptation of music and architecture.	(Xenakis, 2008)
Ernst Chladni	Vibrate the sand grains on the plate through the violin bow	(Chladni, 2015)
Wassily Kandinsky Paul Klee	Convert music to architecture by translating the time interval of sounds into numbers	(Jormakka, 2009)
Hans Jenny	Coined the term Cymatics to describe the acoustic effects of sound wave phenomena.	(Jenny, 2001)
Peter Christensen	Parametric software design includes numbers and ratios to generate 48 virtual forms based on Johann Bach's music	(Christensen, 2008)
Martin Wattenberg	Use arc diagrams and convert music to charts to analyze each music course	(Wattenberg, 2002)
Alessandra Capanna	remarking the idea of self-similarity in composition; Music and Architecture	(Nexus Network Journal, 2009)

There are two experiments in these studies that highly matter to us. One experiment is among the first experiments conducted by the German physicist, Ernst Chladni in 1787. He initially spread some fine sands on a plate and then oscillated them by violin vibrations. These oscillations caused sand grains to form a variety of figures and shapes (Figure 1). Based on the principles of this experiment, a new field of science called Cymatics was developed. Cymatics, meaning “wave”, is a subset of certain phenomena of vibration. The term was coined by Hans Jenny (1904 - 1972), a physician and natural science scholar, to describe the sound effects caused by the sound wave phenomena. These studies actually analyzed the effect of two main characteristics of sound, namely frequency and power of sound on matter. According to their results, this research was designed with another perspective on a mathematical structure to achieve a different goal.

A NEW PARADIGM IN GENERATIVE DESIGN LINKING PARAMETRIC ARCHITECTURE AND MUSIC TO FORM FINDING

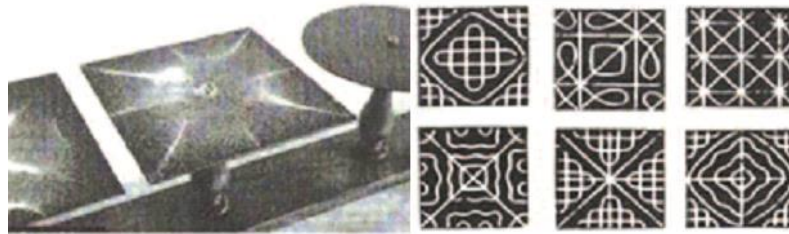

Figure 1. Formation of various roles of sands by vibrations caused by violin vibrations

A lot of research has been done on geometric designs and modular structures. One of the most comprehensive studies by Branko Grünbaum and Geoffrey Colin Shephard (Grünbaum, 1977-1978-1987) analyzed different designs based on mathematical and geometrical principles. Hence, the modeling structures of these studies are highly useful in the process of parameterization of the basic designs and the deformation process in this research.

3.Theoretical framework

The data-driven design and construction are evolving in today's digital world. In fact, built by data is an interdisciplinary project interweaving parametric architecture, engineering, IoT and human-centered design. Given what is done today at many research centers, including the Physical Laboratory at the Technical University of Berlin (CyPhyLab), the theoretical framework of research can be expressed based on such structure as follows.

The approach of parametric architecture in design is based on considering the parameters influencing the design and the relationships between them with the help of mathematics and algorithms. On the other hand, the grammar of music, which is associated with sound oscillations, can be expressed in mathematical language. According to the studies in this field, mentioned in the research literature, and most importantly, the experiments by Ernst Chladni, followed by Hans Jenny, who examined the role of vibrations resulting from different sound frequencies on matter and the formation of geometrical forms, one can conclude that they saw the role of mathematics and geometry as common elements between architecture and music. Thus, it seems that establishing mathematical and geometrical relationships and certain sound characteristics with the help of parametric architecture can be used to introduce a new design method leading to the creation of new forms.

Since music is expressed with the help of sound, it, therefore, has certain characteristics like frequency, amplitude, speed, and direction, all of which can be expressed numerically (Figure 2).

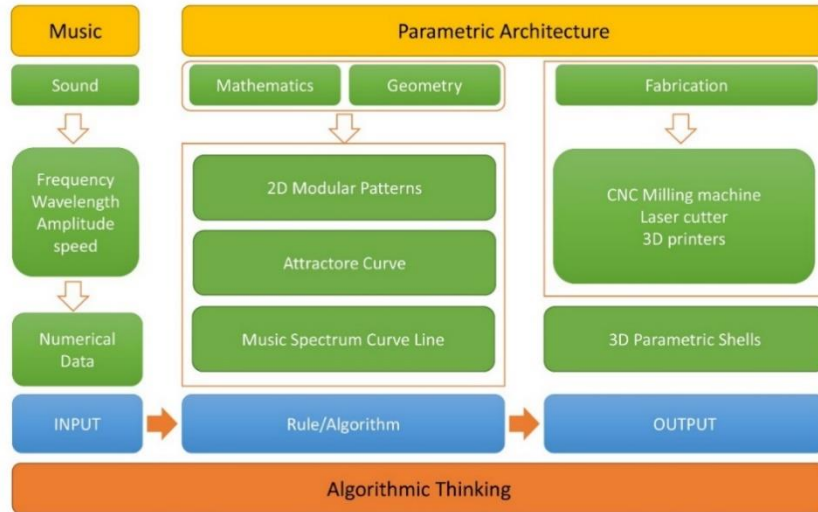

Figure 2. Theoretical framework

4. Research methodology

The design process in parametric architecture is defined as an algorithm in three parts of input, algorithmic process, and output.

Music was defined as the input where the components of sound, frequency and intensity over time play the central role. Moreover, several algorithms (a set of mathematical instructions with specific goals) were written to achieve the final goal – i.e., performing the computational process. Ultimately, the output would be in the form of geometric parametric shells. The algorithms used in this study are as follows:

1. An algorithm that can obtain a nonlinear average frequency spectrum of any music given the role of mathematics in parametric architecture and numerical properties of sound such as frequency and intensity of sound over time.
2. Modular two-dimensional geometric shapes algorithms as basic shapes that can create different geometric patterns based on three deformation methods: Parquet deformation, Hankin, and Rosette.
3. Algorithm for the deformation of those patterns in 3D shapes based on the nonlinear average frequency spectrum of the music. (Attractore Curve)

The simulation process of this research has been carried out in Rhino with Grasshopper and Firefly plugins, and extensive prototyping of the shells was performed at High-performance Architecture Lab (HAL).

A NEW PARADIGM IN GENERATIVE DESIGN LINKING PARAMETRIC ARCHITECTURE AND MUSIC TO FORM FINDING

5. Research process

5.1. AN ALGORITHM FOR CONVERTING MUSIC TO THE MEDIUM FREQUENCY SPECTRUM

Since music is formed based on sound oscillations, it has a wave structure and ups and downs; thus, it has a dynamic and non-linear nature. A specific frequency spectrum is generated in any music at any given moment.

To create a single spectrum from music that generates numerous frequency spectra over time (Figure 3), we need to write an algorithm that calculates the average of each frequency at any given moment (Figure 4). Through this, we can finally achieve the average frequency range of music over time by connecting them together.

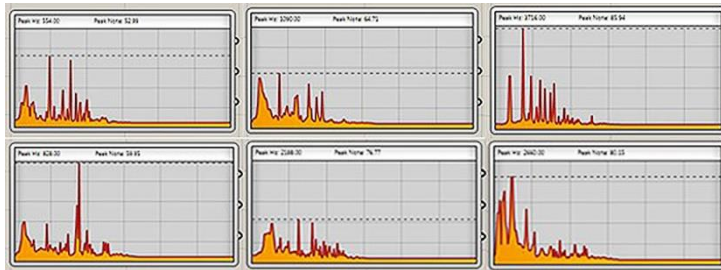

Figure 3. Instantaneous sound frequency spectrum outputs over time in Rhino and Grasshopper

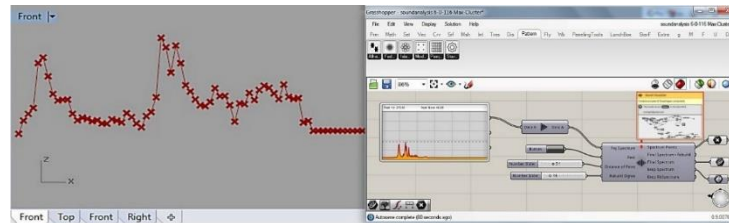

Figure 4. Algorithm for calculating the average frequency spectrum of a music track in the Grasshopper plugin

5.2. MODULAR GEOMETRIC FORMS ALGORITHM

Modular geometric structures were used to create parametric shells based on the music. In general, two types of structures can be defined as a reproducible geometric design (pattern).

- A. Regular patterns or designs (with a basic form)
- B. Combined or hybrid patterns or designs (with two or more basic forms)

Modular geometric structures have a mathematical basis; therefore, along with reproducibility, they can be designed parametrically. Mathematical and geometric methods of pattern deformation (Parquet deformation, Hankin’s method, and Rosette method) were used to deform them.

Euclidean surface segmentation by convex polygons has been widely used in the past. Segmentation is regular and ordered when the geometrical transition is performed on all the shape components (vertices and sides). Accordingly, there is a symmetric function in the structure of regular patterns for each form, in which, the shape resulting from the displacement is connected by the first shape at one side and two vertices. In hybrid patterns with basic forms of more than one model, a sort of tongue and groove structure is created in the geometric transition and the connection is done established more vertices and sides (Figure 5).

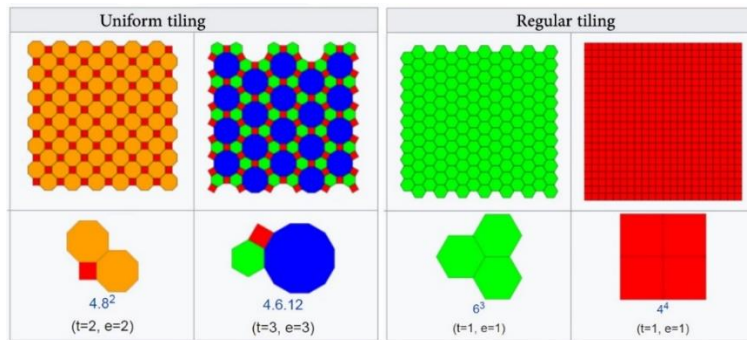

Figure 5. Tiling methods for patterns

The two-dimensional structures were parametrically constructed in Rhino and Grasshopper plugin to create the basic forms algorithms (Figure 6).

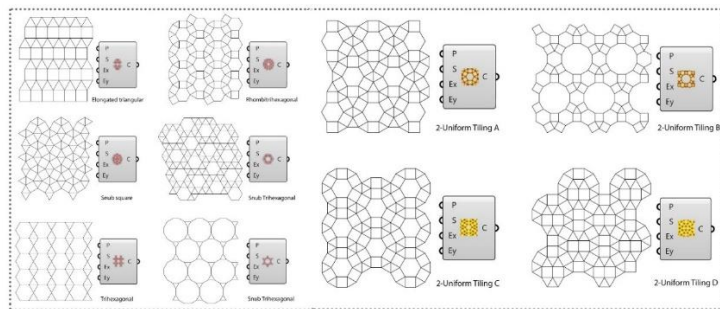

Figure 6: Algorithms of basic forms made parametrically

A NEW PARADIGM IN GENERATIVE DESIGN LINKING PARAMETRIC ARCHITECTURE AND MUSIC TO FORM FINDING

5.3. PATTERN DEFORMATION METHODS

A multitude of new geometric patterns with reproducibility feature can be designed based on pattern deformation methods.

5.3.1. Parquet Deformation

This deformation is a kind of spatial animation (a geometric design) that results in a uniform spatial transition. These deformations are a style of decorative designs created by William Huff, which have been later popularized by Douglas Hofstadter (Hofstadter, 1986). The parquet deformation is very close to M. C. Escher deformation images (Bool, Kist, Wierda and Locher, 1992) (Figure 7).

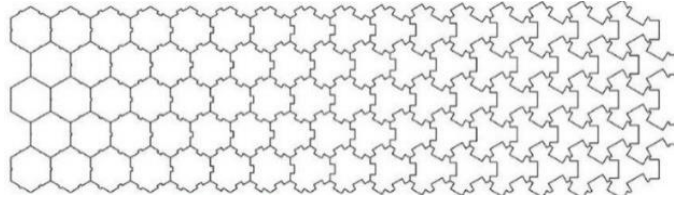

Figure 7. Three-leaf, designed by Glenn Paris at Huff Studio in 1996, remodeled by author after Hofstadter (Hofstadter, 1986)

Based on the same structure, this model was developed in the Grasshopper plugin based on the Attractor Point and then Attractor Curve models (Figure 8).

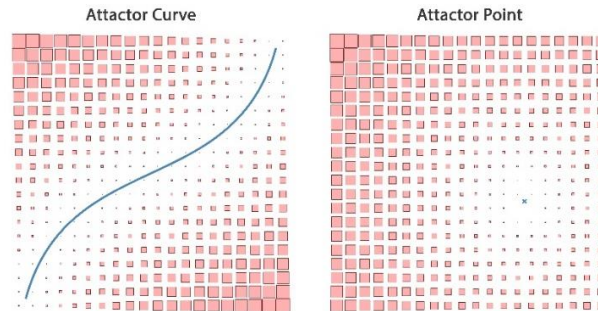

Figure 8: Base Pattern Deformation Based on parquet deformation method

5.3.2. Hankin's Method

It is a method of generating non-alternating deformations based on the gradual change of the angle of contact of the sides in the basic pattern (Hankin, 1925) (Figure 9). This method is widely used in Islamic art designs. The analysis of the two-dimensional art works with Islamic patterns provides the opportunity to discover many structural similarities between art and mathematics (Abas

and Salman, 1995). These fundamental shapes give rise to hundreds of different designs, and merely altering an angle or curving a straight line can create an entirely new pattern (Bourgoin, 1973).

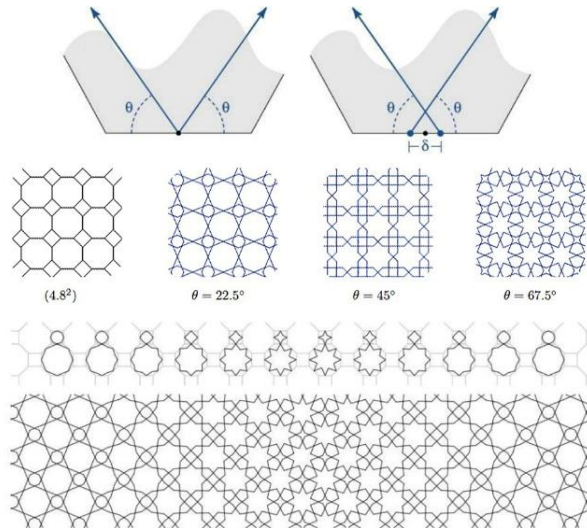

Figure 9. Deformation angle of contact on the stellar pattern of Islamic architecture in Hankin's method (Kaplan, 2002)

5.3.3. Rosette Deformation

This deformation begins based on the bisectors that start from the sides and go inside the initial form with a specified length, and then, their endpoints are connected together (Figure 10).

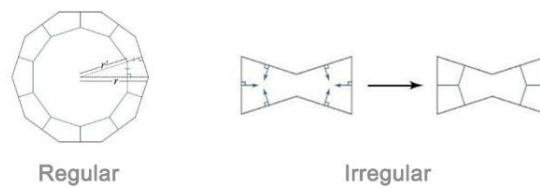

Figure 10. (Right) Rose deformation in an irregular polygon, (Left) Rose deformation in a regular polygon

5.4. AN ALGORITHM FOR DEFORMING DESIGNS INTO THREE-DIMENSIONAL FORMS

Based on the attractor method mentioned earlier, a nonlinear medium frequency spectrum resulting from music was used as the attractor curve. This curve is placed on the designed two-dimensional patterns. A coefficient of

A NEW PARADIGM IN GENERATIVE DESIGN LINKING PARAMETRIC ARCHITECTURE AND MUSIC TO FORM FINDING

similitude, height, and a center of gravity are individually defined for each of the patterns. Based on the mathematical structure of the attractor curve, as the center of gravity of these patterns distances from the attractor curve (the curve resulting from the music), the effect of the frequency and intensity of the music on that pattern decreases, and vice versa. As a result, the peak of the pattern near the attractor curve is higher and descends as its distance increases, so that the final shell has a soft deformation.

In this research, extensive prototypes were made with different music soundtracks at Tarbiat Modarres University's Modern Architecture Technologies Laboratory (HAL) (Figure 11). One of these samples has been implemented with a practical approach at a large-scale for theoretical testing.

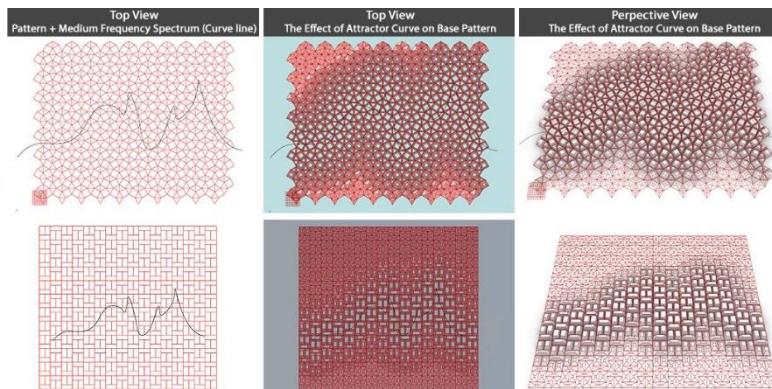

Figure 11. Different prototypes in the Rhino software and the Grasshopper plugin

6. Modeling and implementation

In this project, a part of an Iranian music piece by Homayoun Shajarian (a top Persian traditional music singer) and Sohrab Pournazeri (composer) was used as the algorithm input and its nonlinear medium frequency spectrum was obtained. Using the basic geometric algorithms and deformation methods described earlier, we created the initial pattern of rosette geometrics and Gereh-Chini in a two-dimensional form, which is found in Iranian architecture. Then, based on the Attractor Curve algorithm, the effect of that nonlinear medium spectrum resulting from the music was applied to the designed two-dimensional patterns. The output was a parametric three-dimensional shell that was affected by a specific music piece. The output of each module was obtained with the help of Rhino software and Grasshopper plugin. The methods used for making this project were laser cutting techniques, folding and welding. The components of the wall are 340 non-

similar pieces which are joined to each other with 552 different angles (Figure 12).

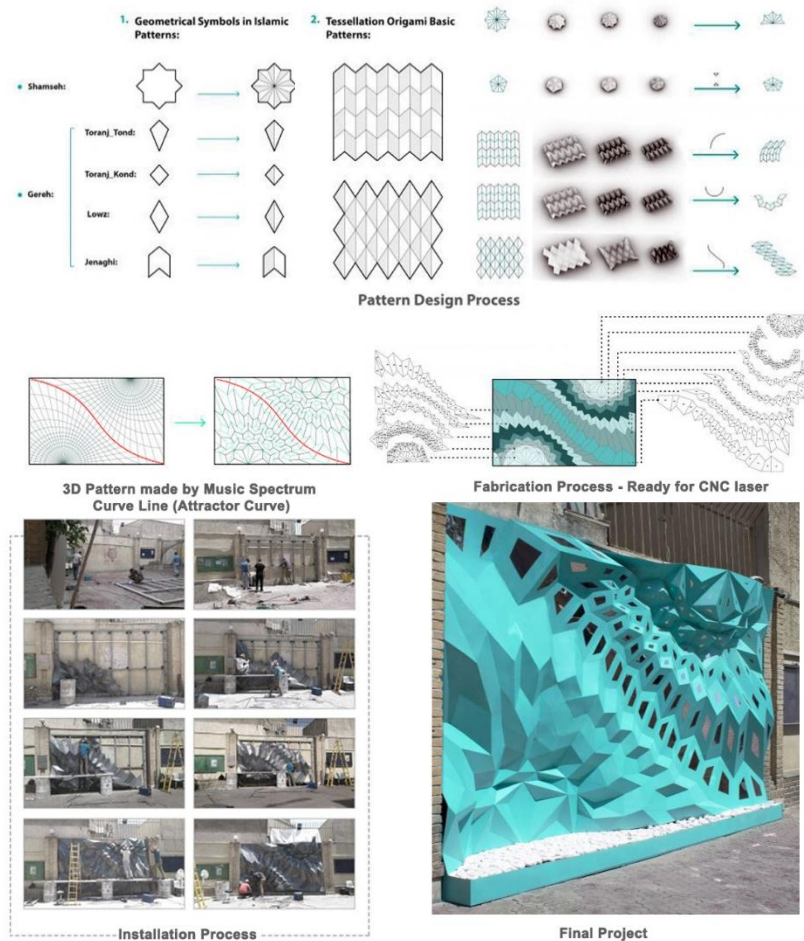

Figure 12: Design and construction of parametric wall based on a piece of music by Homayoun Shajarian and Sohrab Pournazeri

7. Conclusion

Since architecture involves designing, it always seeks creativity, and thus, it requires up-to-date technology and knowledge to realize and build innovative designs. One method of developing creativity in architecture is to focus on interdisciplinary topics. The relationship between architecture and music is among such topics.

A method of designing and constructing new forms as a productive design was introduced. Two main characteristics of sound i.e., frequency and intensity of sound over time, can be used to create a nonlinear medium

A NEW PARADIGM IN GENERATIVE DESIGN LINKING PARAMETRIC ARCHITECTURE AND MUSIC TO FORM FINDING

frequency spectrum using the numerical outputs resulting from the music. Then, it can be used to deform modular two-dimensional geometric patterns based on Attractor Curve algorithm, which are produced and reproduced based on mathematical relationships and different geometric methods (Hankin, Parquet deformation, and Rosette deformation) to achieve 3D parametric shells based on music. This research is an applied work and it can be used on a large scale such as urban landscape and a small scale as interior design. In summary, the whole process of this study can be illustrated in Figure 13.

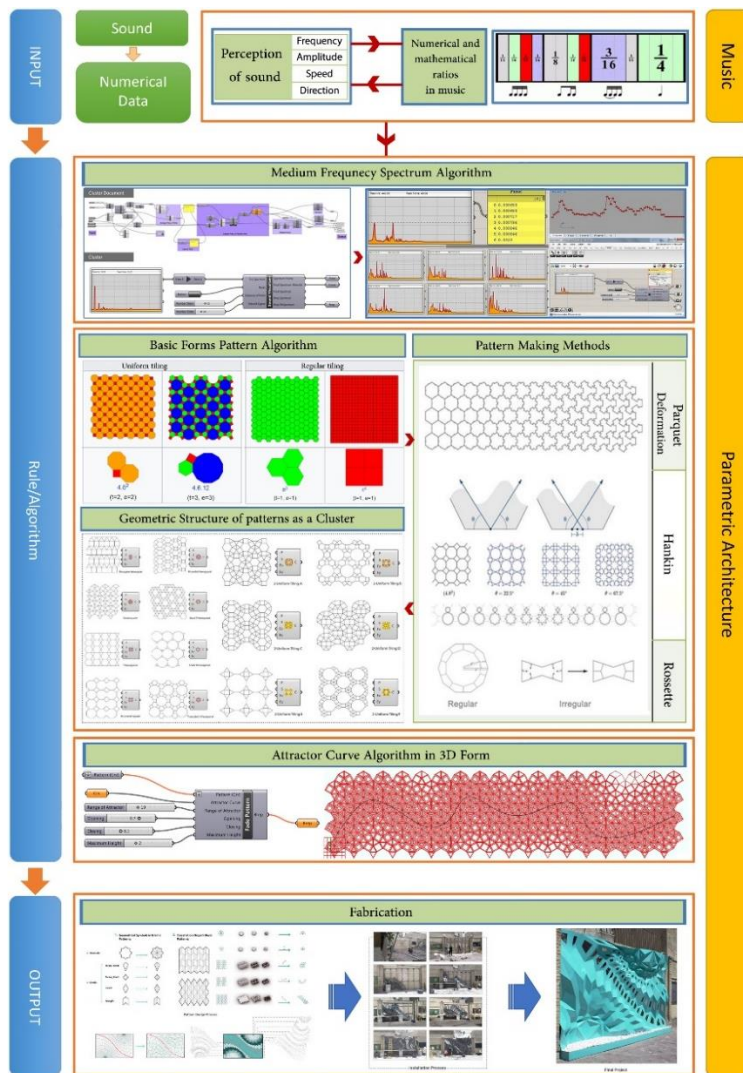

Figure 13. The process of converting music into an architectural form based on an algorithmic process

References

- ABAS, S.J. AND SALMAN, A.S., 1995. *Symmetries of Islamic Geometrical Patterns*, World Scientific.
- AMINI, M., MAHDAVINEJAD, M. AND BEMANIAN, M., 2019. Future of interactive architecture in developing countries: Challenges and opportunities in case of Tehran, *Journal of Construction in Developing Countries*, 24(1), pp. 163-184.
- ANTONIADES, A.C., 1992. *Poetics of Architecture (theory of design)*, Wiley.
- BOOL, F.H., KIST, J.R., WIEDRA, F. and LOCHER, J.L., 1992. M.C. Escher: His Life and Complete Graphic Work, *Harry N. Abrams, Inc.*
- BOURGOIN, J., 1973. Arabic Geometrical Pattern and Design, *Dover Publications Inc.*
- CAPANNA, A., 2009. Music and Architecture: A Cross between Inspiration and Method, *Nexus Network Journal* 11, pp.257-272.
- CHING, F.D.K., 2007. *Architecture; Form, Space and Order*, Wiley.
- CHLADNI, E.F.F., 2015. *Treatise on Acoustics*, Springer.
- CHRISTENSEN, P. AND SCHNABEL, M.A., 2008. Spatial polyphony: Virtual Architecture Generated from the Music of J.S. Bach, *CAADRIA 2008*.
- GRÜNBAUM, B. AND SHEPHARD, G.C., 1977. Tilings by Regular Polygons, *Mathematics Magazine*, 50(5), pp. 227-247.
- GRÜNBAUM, B. AND SHEPHARD, G.C., 1978. The ninety-one types of isogonal tilings in the plane, *Transactions of the American Mathematical Society*, 242, pp. 335-353.
- GRÜNBAUM, B. AND SHEPHARD, G.C., 1987. *Tilings and Patterns*, W. H. Freeman & Company, New York.
- HANKIN, E.H., 1925. The Drawing of Geometric patterns in Saracenic Art, *Memoirs of the Archaeological Survey of India*, 15, p.4.
- HOFSTADTER, D., 1986. *Metamagical Themas: Questing for the Essence of Mind and Pattern*, Bantam Books.
- JENNY, H., 2001. *Cymatics: A Study of Wave Phenomena & Vibration*, MACROmedia Publishing.
- JORMAKKA, K., 2009. *Basics Design Methods*. Berlin, Birkhauser Press.
- KAPLAN, C.S., 2002. *Computer Graphics and Geometric Ornamental Design*, Ph.D. Thesis, University of Waterloo.
- WATTENBERG, M., 2002. Arc Diagrams: Visualizing Structure in Strings, *Proceedings of the IEEE Symposium on Information Visualization 2002 (InfoVis'02)*.
- WERNER, L.C., 2011. Codes in the Clouds Observing New Design Strategies, *Complexity and Responsibility: Proceedings of the Design Modeling Symposium Berlin 2011*, Berlin, pp. 63-70.
- WERNER, L.C., 2015. In quest of code. Design Ecologies, *Intellect*, 4(1-2), pp. 62-89.
- WERNER, L.C., 2019. Form and Data - from linear Calculus to cybernetic Computation and Interaction, *eCAADe + SIGraDi 2019*, pp. 675-682.
- XENAKIS, I. 2008. *Music and Architecture*, Pendragon Press; annotated edition.

DIGITALLY ENCODED WOOD

4D Printing of Hygroscopic Actuators for Architectural Responsive Skins

RANA EL-DABAA

Arab Academy for Science, Technology and Maritime Transport
rana.bahaa@aast.edu

ISLAM SALEM

Arab Academy for Science, Technology and Maritime Transport
Ain Shams University
islamibrahim@aast.edu

AND

SHERIF ABDELMOHSEN

American University in Cairo
sherifmorad@aucegypt.edu

Abstract. This paper exploits passive responsive actuators as a passive approach for adaptive façades. The study encodes the embedded hygroscopic parameters of wood through 4D printing of laminated wooden composites as a responsive wooden actuator. Several experiments focus on controlling the printed hygroscopic parameters based on the effect of 3D printing patterns and infill height on the wooden angle of curvature. We present a set of controlled printed hygroscopic parameters that stretch the limits in controlling the response of wood to humidity instead of the typical natural properties of wood. The results show a passive programmed self-actuated mechanism that can enhance responsive façade design with zero energy consumption through utilizing both material science and additive manufacturing mechanisms. This passive responsive mechanism can be utilized in adaptive facades for dynamic shading configurations.

Keywords: *Hygroscopic properties of wood, passive actuation, adaptive facades, programmable materials, 4D wood printing*

ملخص. يقدم البحث طريقة لتصميم محركات ميكانيكية بتصميم سلبي حيث لا تستهلك طاقة للحركة. تستخدم هذه المحركات في الواجهات التفاعلية بحيث تستجيب للتغير في نسبة الرطوبة. تستهدف الدراسة الخصائص الإسترطابية المدمجة للخشب من خلال الطباعة رباعية الأبعاد للمحركات الميكانيكية بالخشب. يعتمد البحث على العديد من التجارب للتحكم في المعاملات الإسترطابية المطبوعة للخشب بناءً على تأثير أنماط الطباعة ثلاثية الأبعاد و سمك الخشب على زاوية الانحناء للخشب عند تعرضه لإختلاف في نسبة الرطوبة. يقدم البحث مجموعة من الخصائص الإسترطابية المطبوعة القابلة للتحكم والتي تتيح التحكم في استجابة الخشب المطبوع للرطوبة بدلاً من استخدام الخشب الطبيعي. تُظهر النتائج إمكانية برمجة الخشب كمحركات ذاتية التشغيل و لتحسين تصميم الواجهات التفاعلية وذلك بدون استهلاك للطاقة من خلال دمج دراسة خصائص المواد مع آليات تصنيعها. يوضح البحث إمكانية استخدام آلية الاستجابة السلبية المتواجدة في الخاصية الإسترطابية للخشب في تحسين كفاءة الواجهات التفاعلية من إختلاف أنماط الظل الديناميكية على المباني.

الكلمات المفتاحية: خصائص الإسترطابية للخشب, محركات سالبة بدون طاقة, واجهات التفاعلية, مواد قابلة للبرمجة, طباعة رباعية الأبعاد.

1. Introduction: Wood as a Programmable Material

Programmable materials are specifically fabricated materials that respond to external stimuli. Hygroscopic properties of wood have been studied as a programmable material that responds passively to changes in humidity levels to encompass complex programmed motion responses according to its embedded and controlled parameters (Reichert et al., 2015; Rüggeberg and Burgert, 2015; El-Dabaa et al., 2020a; El-Dabaa and Abdelmohsen, 2020). Numerous studies tested the ability of wood to be encoded as a passive programmed material that responds to humidity levels (Abdelmohsen et al., 2019a; Abdelmohsen et al., 2019b; Vazquez et al., 2019; Reichert et al., 2015).

There still exists a lack of customized geometric configurations and double curved surfaces due to the nature of wood. Typically, 3D printing is used for static fabrication rather than interactive design. Printable fabrication techniques rely on printing several parts that are connected and used as a base for programmable skins (Raviv et al., 2015). Utilizing additive manufacturing in the process of 4D printing hygroscopic programmable materials has been studied as an approach to encode passive motion responses (Tibbits et al., 2014; Wood et al., 2016; Le Duigou et al., 2020). This study introduces a passive programmed self-actuated mechanism that can enhance responsive façade design with zero energy consumption through utilizing both material science and additive manufacturing mechanism. We explore the ability of 4D printing hygroscopic hinges and joint prototypes as an embedded actuator that responds passively to humidity levels. It focuses on studying the parameters of printing hygroscopic hinges as part of a programmable façade. Geometric patterns and infill properties are illustrated as additive hygroscopic parameters. The bending motion

DIGITALLY ENCODED WOOD: 4D PRINTING OF HYGROSCOPIC ACTUATORS FOR ARCHITECTURAL RESPONSIVE SKINS

response is evaluated through measuring the variation of wooden angles of curvature when exposed to the same humidity levels. Average measurements of the angles of curvature are taken using the “Kinovea” image analysis software.

2. Natural Wood and 4D Printed Wood Filaments

Several studies have explored the effect of hygroscopic parameters of wood on its motion response and the ability to encode wood motion response in the form of single or double curved surfaces according to hygroscopic parameters (Abdelmohsen et al., 2019a; Holstov et al., 2017; Holstov et al., 2015). Hygroscopic parameters have been divided into two types: embedded and controlled design parameters. Embedded parameters are mainly the parameters that are related to the inherent material properties such as the type of wood, grain orientation, thickness, and dimensional ratio of a given sample, while controlled parameters are related to human interference on those embedded parameters such as the fixation position of a sample or isolating specific segments of the sample (El-Dabaa et al., 2020b; El-Dabaa et al., 2020a; Abdelmohsen et al., 2019c).

It was shown that one of the most effective parameters in designing for changes in wood morphology is grain orientation, which is the direction of wood fibers along the long axis. The ability of wood to absorb and retain moisture content is mostly related to grain orientation. Figure 1 shows the difference in response behavior of wood in relation to grain orientation.



Figure 1. The response of Beech veneer samples with different grain orientations to increase in humidity (from left to right: 90° grain orientation, 45° grain orientation and 0° grain orientation) (Abdelmohsen et al., 2019a)

As a base case, and to establish a reference to the study of 4D printing wood, we conducted a series of experiments on natural wood samples to identify the typical responses for different basic grain orientations. For Beech veneer samples with a tangential cut, and upon increase in humidity, the results demonstrated that the highest bending or deflection value and fastest response takes place with the 0° grain orientation, with an average angle of curvature of 36° (fibers parallel to the long axis), while the least deflection value with the slowest response takes place with the 90° grain orientation (fibers perpendicular to long axis), as illustrated in TABLE 1.

TABLE 1. Grain orientation effect on deflection value, type of motion and response speed in Beech veneer samples.

Grain orientation	90 °	45 °	0 °
Deflection value	Lowest	Medium	Highest
Response speed	Slowest	Fast	Fast
Type of motion	Bending along the long axis of sample	Twisting along the diagonal axis of sample	Bending along the short axis of sample

We then explored the ability to encode the embedded parameters through the process of 4D printing of wooden responsive actuators. 4D printing is used to encode wood embedded parameters, specifically focusing on wood grain orientation. The printing process controls grain orientation to produce a variety of motion types with single and double surfaces when exposed to differences in humidity levels, as shown in Figure 2.

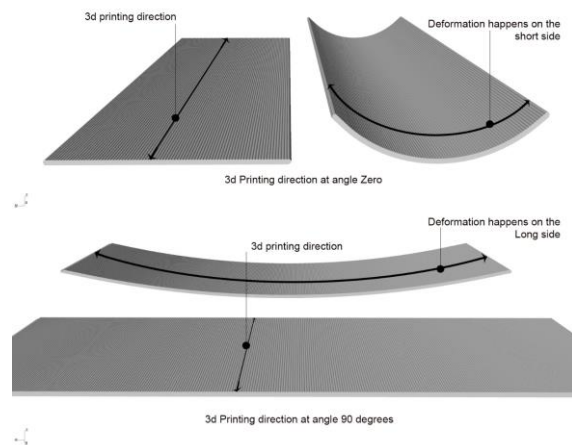

Figure 2. The effect of printed wood grain on its motion response when exposed to differences in humidity levels.

As a pilot study, we compared the deflection of natural wood (Beech veneer) to that of a 3D printed wood sample with the same orientation and dimensional ratio. Figure 3 shows a comparison between the angle of curvature achieved from natural Beech wood and 3D printed wood (20% wood filament and 80% plastic filament) with 0° grain orientation. The natural wood angle of curvature was shown to be 36° on average, while the angle of curvature of the 3D printed wood sample was 167° on average, indicating a higher deflection in natural wood samples.

DIGITALLY ENCODED WOOD: 4D PRINTING OF HYGROSCOPIC ACTUATORS FOR ARCHITECTURAL RESPONSIVE SKINS

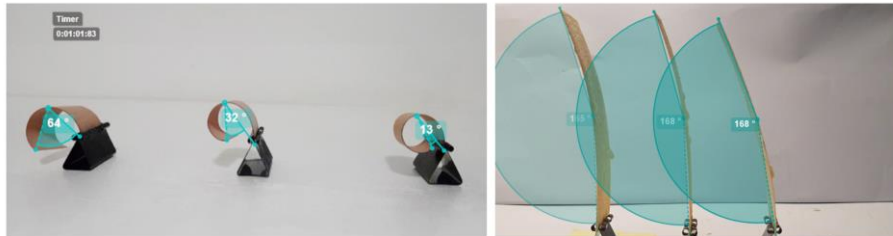

Figure 3. Comparing average angle of curvature between Beech natural wood (left), and 3D printed wood (right) (20% wood, 80% plastic)

3. Encoding Printed Wood Motion Response

3.1. MATERIAL AND METHOD

The process of experimenting with 4D printing was divided into three phases; (1) the 4D printing phase that includes the material tested parameters and printing setup, (2) Physical experiments on the printed samples that encompasses the vertical fixation of samples, increasing the humidity levels and documenting the experiments using a digital camera, and (3) analyzing the angle of curvature for each 4D printed wooden sample through the “Kinovea” validated image analysis software, as shown in Figure 4.

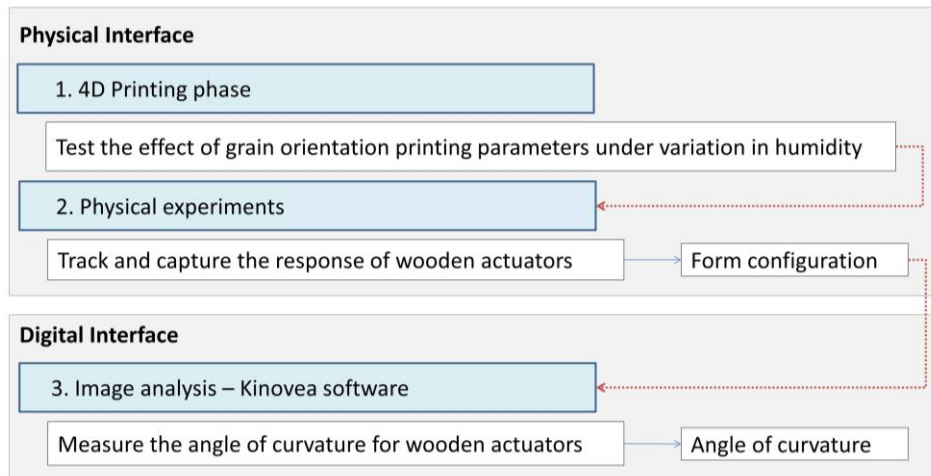

Figure 4. Research Workflow

A series of experiments were conducted to measure the effect of 3D printed hygroscopic parameters on the angle of curvature of the wooden printed actuator. The measured angle of curvature lies between the two end points and the midpoint of the sample, as shown in

Figure 5. The tested samples were fixed vertically with clamps to avoid friction with the surface. Increase in humidity was applied by means of spraying water on a single side of the printed samples. The angle of curvature was measured as the maximum deflection value for each experiment.

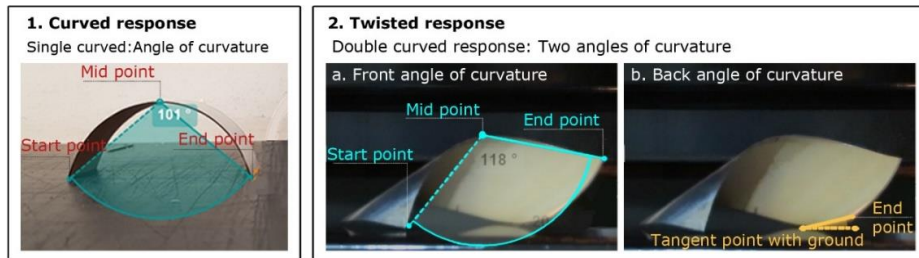

Figure 5. Image analysis measurement method used in the Kinovea image analysis software (El-Dabaa et al., 2020a)

3.2. 4D PRINTING PARAMETERS

Wooden filaments were used for the purpose of the conducted experiments, with 80% PLA and 20% wood. The dimensional ratio of the tested samples was 1:3 (4*12cm.) with a thickness of 0.3mm. This dimensional ratio was used as a basis for the experiments, as it was demonstrated in earlier studies that it exhibits fairly higher deflection than 1:2 or 1:1 sample ratios. In terms of single layer thickness, the 0.3mm thickness was chosen as a threshold for 4D printing the thinnest possible layer with the highest anticipated deflection. Thicknesses below 0.3mm were shown to break upon printing. The programmable wooden actuators were printed using an FDM printer and Cura 4.8 software with filament diameter 1.75mm and nozzle size 0.4mm. The printing parameters are shown in TABLE 2.

TABLE 2. Extrusion and printing parameters

Printing Parameters	
Material	Wood PLA
Filament Diameter	1.75mm
Slicing software	Cura 4.8
Extruder temperature (°C)	220 (°C)
Build plate temperature (°C)	55 (°C)
Nozzle size	0.4mm
Layer thickness	0.3
Printing speed	60 mm/s
Printer used	FDM printer
Extrusion multiplier	100%

3.3. CONTROLLED PRINTED HYGROSCOPIC PARAMETERS

The study proposes a 4D printed hygroscopic joint prototype that is used as a passive actuated skin upon variation in humidity levels. The wooden joints are characterized by their zero-energy consumption and immediate response to humidity levels around the façade. We tested several printed hygroscopic parameters that were seen to manipulate the response behavior of the printed wooden samples in a controlled manner. Three parameters were tested against the wooden angle of curvature.

The samples were marked from the midpoint and endpoint to facilitate tracking of the sample in the “Kinovea” image analysis software, as a validated motion tracking method (Puig-Diví et al., 2017; Abdelmohsen et al., 2018). The results were then exported and analyzed in Microsoft Excel. The average angle of curvature for each grain orientation was recorded. Humidity was applied on a single side of the sample. Lamination was not applied and is out of the scope of this paper. The two sections below describe two newly introduced parameters that were seen to affect the deflection of the 4D printed samples: (1) grain patterns and (2) infill height.

3.3.1. 3D Printed Grain Patterns

In this experiment, the angle of curvature was tested on three wooden samples with different grain orientations when exposed to increase in humidity. The tested grain orientations varied in the patterns of the linear grains, as follows: (1) parallel lines with 0° grain orientation, (2) zigzag straight lines and (3) concentric straight lines, as shown in Figure 6. These patterns were selected based on several trials with different configurations and were seen as the patterns with the most significant response within linear printing. The experiments showed that the parallel grains with 0° had the highest angle of curvature with angle 167°, followed by the zigzag straight lines with angle 171°, while the concentric straight-line pattern had a double curved surface with the least angle of curvature 177° from the long side. The results of the first sample (0° grain orientation) were shown to match the behavior of natural wood samples, only with lower deflection. The patterns and configurations in the other tested samples however do not exist in natural wood and are not comparable. Therefore, the 4D printed wood was observed to allow for developing new wooden prototypes that achieve novel controllable motion morphologies.

3.3.2. Infill Height

With natural wood, sample thickness is typically shown to affect motion response. Previous studies show that thicker wooden samples demonstrate lower angles of curvature with slow speed rate of response (Abdelmohsen et al., 2019b; El-Dabaa et al., 2020a). Natural wood however has a uniform thickness for the whole sample and is not a parameter that can be controlled or regulated. Controlling specific segments in natural wood samples requires isolating specific parts of the sample or laminating different segments with specific percentages (El-Dabaa et al., 2020b).

Another parameter that was deduced upon experimenting with 4D printing was the infill height of the printed material. In 4D printing, it is possible to have different thicknesses within the same sample. This gives an effect similar to that of varying sample thickness and the isolation of specific sample segments. 4D printing settings can be controlled to have a gradient or different thickness within the same printed wooden sample. In this experiment, the control of specific parts of the wood were tested through controlling the difference in the thicknesses in one sample.

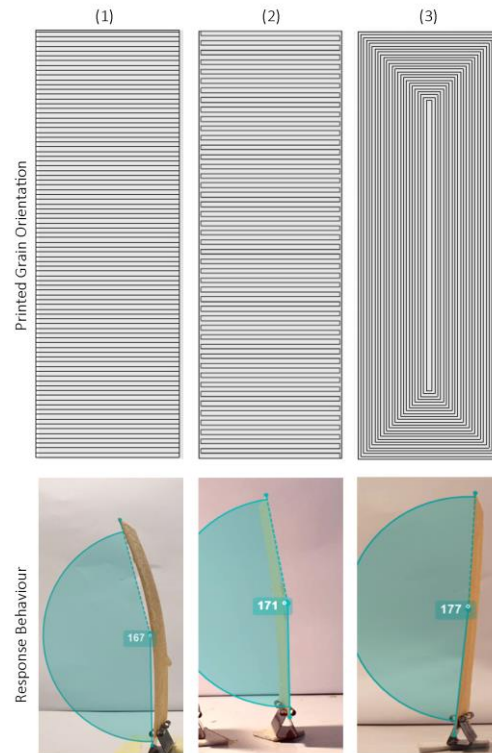

Figure 6. Effect of printed grain orientations on the angle of curvature when exposed to increase in humidity (1) parallel lines 0°, (2) zigzagged straight lines, (3) concentric straight lines.

DIGITALLY ENCODED WOOD: 4D PRINTING OF HYGROSCOPIC ACTUATORS FOR ARCHITECTURAL RESPONSIVE SKINS

Encoding different thicknesses in one single wooden sample was applied by controlling the infill height in the 3D printing process. The typical height of the infill used was 0.3mm and 0.6mm. Three infill configurations were tested to achieve different motion morphologies, as shown in Figure 7. The angle of curvature was evaluated for each infill height. The first sample was divided into two equal parts with 0.3mm and 0.6mm each. This resulted in a motion of the 0.3mm segment of the sample as the main hinge in the wooden sample. The second sample was composed of two thirds 0.3mm thick at the two ends of the sample with a 0.6mm third in the middle of the sample. This resulted in a curvature at the two ends only, while the middle segment exhibited a very slight deflection and was almost flat. The third sample had an infill height of 0.3 mm in the middle third and two thirds of infill height 0.6mm at the two ends. Higher deflection was observed in the middle segment while the two ends exhibited slight deflection and were almost flat. These experiments show that that the segments of the wooden sample with 0.3mm infill height exhibited higher deflection values than the 0.6mm infill height segments.

The results demonstrate an added value to hygroscopic controlled parameters, leading to a wider variety of anticipated motion morphologies and grammars. It also demonstrates the capacity of 4D printed samples to control motion in specific segments of the printed wooden sample as a responsive hinge. This opens the door to print several configurations using the infill height, resulting in controlled printed hinge responses.

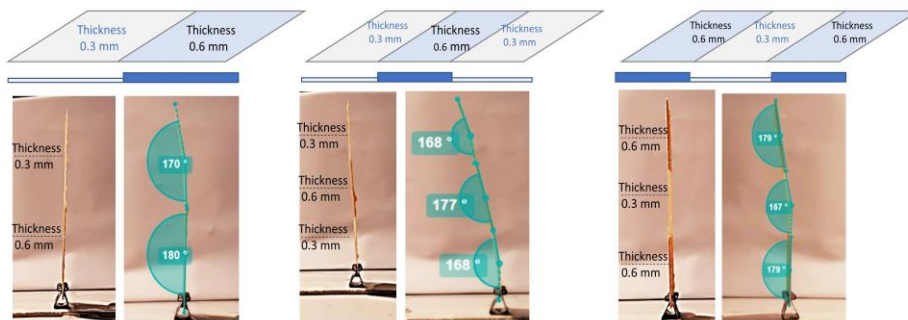

Figure 7. Effect of controlled printing infill height when exposed to increase in humidity.

4. Discussion and Conclusion

Architectural adaptive facades typically involve mechanical systems with sensors and actuators of high energy demand for their operation. Fox and Kemp led the “End of Mechanism” paradigm that replaces the mechanical with passive systems (Fox, 2016). Hingeless adaptive systems have been

recently introduced based on biological systems by controlling their passive motion response. Programmable and smart materials have also been developed as passive systems that respond to external stimuli such as temperature or humidity (Kretzer, 2017).

This paper utilized the concept of 4D printed wooden actuators in adaptive facades as passive responsive actuators that respond to variation in humidity levels. These 4D wooden printed actuators are developed as zero-energy consumption motion mechanisms. The actuators can handle light-weight shading devices. The number of printed wooden actuators on a façade is calculated according to the weight of the shading device.

The contribution of this research lies in introducing additional controlled parameters to the set of conventionally established hygroscopic parameters, resulting in the definition of additional motion response morphologies and grammars. Previously established hygroscopic parameters in natural wood typically involve embedded parameters (such as grain orientation, type of wood, dimensional ratio, thickness, and lamination) and controlled parameters (such as fixation type and position, and isolation type and position).

In this paper, we introduce new parameters related to artificial printing. These include printed grain patterns and infill height. The added value of introducing such parameters in the 4D printing process lies in introducing additional controlled parameters that can emulate natural wood response by understanding deflection and motion response speed with a higher level of precision, durability and reversibility, therefore mitigating aspects of fatigue and material deterioration in natural settings and conditions. A clear limitation is the limited deflection value when compared to natural wood angles of curvature and response speed. Arriving at thicknesses equivalent to natural wood veneer where higher deflection values are anticipated is currently not possible, where samples with less than 0.3mm are fragile and are not printed successfully. However, the use of 4D printed hinges and actuators can be strategically located in adaptive façade systems where necessary and where a high degree of precision and durability is required.

These newly introduced parameters still require analysis in terms of hygroscopic motion grammars that allow for tracking, documenting and programming the effect of each parameter on motion morphologies and the ability to merge several parameters to achieve additional motion morphologies. Lamination is yet another parameter to be tested with printed wood.

The printing parameters of wooden samples demonstrate the ability to control their passive motion more than natural wood hygroscopic properties, with a higher capacity to instill specific patterns and configurations that are customized in terms of both thickness and location on the sample. Another clear limitation is the percentage of wood in the sample (20% wood as

DIGITALLY ENCODED WOOD: 4D PRINTING OF HYGROSCOPIC ACTUATORS FOR ARCHITECTURAL RESPONSIVE SKINS

opposed to 80% plastic). Further investigations require testing with filaments of higher percentage of wood than plastic to simulate the natural wood angle of curvature when exposed to increase in humidity levels. This is expected to affect the significance of the deflection values and perhaps the response speed of the printed sample.

The focus in this paper mostly involved emulating the thickness and grain orientation controlled parameters and the isolation embedded parameters, in addition to introducing new parameters such as grain pattern. Future testing will include an emulation of more controlled and embedded parameters such as dimensional ratio, lamination and fixation. With further testing, future work will implement the deduced 4D printing parameters as responsive hinges in adaptive facades, shading devices, and responsive structures.

Acknowledgment

The Authors are grateful for the fund provided by Bartlett's Fund for Science and Engineering Research Collaboration, in a research project collaboration between Princeton university and The American university in Cairo.

References

- Abdelmohsen, S., Adriaenssens, S., El-Dabaa, R., Gabriele, S., Olivieri, L., Teresi, L., 2019a. A multi-physics approach for modeling hygroscopic behavior in wood low-tech architectural adaptive systems. *Computer-Aided Design* 106, 43–53. <https://doi.org/10.1016/j.cad.2018.07.005>
- Abdelmohsen, S., Adriaenssens, S., Gabriele, S., Olivieri, L., El-Dabaa, R., 2019b. Hygroscapes: Innovative Shape Shifting Façades, in: Bianconi, F., Filippucci, M. (Eds.), *Digital Wood Design: Innovative Techniques of Representation in Architectural Design*, Lecture Notes in Civil Engineering. Springer, Switzerland, pp. 675–702. https://doi.org/10.1007/978-3-030-03676-8_26
- Abdelmohsen, S., Massoud, P., El-Dabaa, R., Ibrahim, A., Mokbel, T., 2019c. The Effect of Hygroscopic Design Parameters on the Programmability of Laminated Wood Composites for Adaptive Façades, in: Lee, J.-H. (Ed.), *Computer-Aided Architectural Design*. "Hello, Culture." Springer Singapore, Singapore, pp. 372–383. https://doi.org/10.1007/978-981-13-8410-3_26
- Abdelmohsen, S., Massoud, P., El-Dabaa, R., Ibrahim, A., Mokbel, T., 2018. A Computational Method for Tracking the Hygroscopic Motion of Wood to develop Adaptive Architectural Skins, in: *ECAADe 2018: 6th Annual Conference on Education and Research in Computer Aided Architectural Design in Europe*. Lodz, Poland, pp. 1–9.
- El-Dabaa, R., Abdelmohsen, S., 2020. Deriving the Production Rules of Shape-Shifting Grammars for Adaptive Façades: The Case of Hygromorphic Thermo-bimetal Composites (HMTM), in: *9th International Conference on Design Computing and Cognition (DCC20)*. Georgia Institute of Technology, Atlanta, USA.
- El-Dabaa, R., Abdelmohsen, S., Mansour, Y., 2020a. Encoding Latent Properties of Hygromorphic-Thermobimetal Composites as a Passive Mechanism for Adaptive Building Skins, in: Kamel, S., Sabry, H., Hassan, G.F., Refat, M., Elshater, A.,

- Elrahman, A.S.A., Hassan, D.K., Rashed, R. (Eds.), *Architecture and Urbanism: A Smart Outlook*. Springer International Publishing, Cham, pp. 133–145. https://doi.org/10.1007/978-3-030-52584-2_10
- El-Dabaa, R., Abdelmohsen, S., Mansour, Y., 2020b. Programmable passive actuation for adaptive building façade design using hygroscopic properties of wood. *Wood Material Science & Engineering* 1–14. <https://doi.org/10.1080/17480272.2020.1713885>
- Fox, M. (Ed.), 2016. *Interactive architecture: adaptive world*, First edition. ed, Architecture briefs. Princeton Architectural Press, New York.
- Holstov, A., Bridgens, B., Farmer, G., 2015. Hygromorphic materials for sustainable responsive architecture. *Construction and Building Materials* 98, 570–582. <https://doi.org/10.1016/j.conbuildmat.2015.08.136>
- Holstov, A., Farmer, G., Bridgens, B., 2017. Sustainable Materialisation of Responsive Architecture. *Sustainability* 9, 435. <https://doi.org/10.3390/su9030435>
- Kretzer, M., 2017. *Information materials: smart materials for adaptive architecture*. Springer International Publishing, Switzerland.
- Le Duigou, A., Chabaud, G., Matsuzaki, R., Castro, M., 2020. Tailoring the mechanical properties of 3D-printed continuous flax/PLA biocomposites by controlling the slicing parameters. *Composites Part B: Engineering* 203, 108474. <https://doi.org/10.1016/j.compositesb.2020.108474>
- Puig-Diví, A., Padullés-Riu, J.M., Busquets-Faciabén, A., Padullés-Chando, X., Escalona-Marfil, C., Marcos-Ruiz, D., 2017. Validity and Reliability of the Kinovea Program in Obtaining Angular and Distance Dimensions. *Preprints* 1. <https://doi.org/10.20944/preprints201710.0042.v1>
- Raviv, D., Zhao, W., McKnelly, C., Papadopoulou, A., Kadambi, A., Shi, B., Hirsch, S., Dikovskiy, D., Zyracki, M., Olguin, C., Raskar, R., Tibbits, S., 2015. Active Printed Materials for Complex Self-Evolving Deformations. *Scientific Reports* 4. <https://doi.org/10.1038/srep07422>
- Reichert, S., Menges, A., Correa, D., 2015. Meteorosensitive architecture: Biomimetic building skins based on materially embedded and hygroscopically enabled responsiveness. *Computer-Aided Design* 60, 50–69. <https://doi.org/10.1016/j.cad.2014.02.010>
- Rüggeberg, M., Burgert, I., 2015. Bio-Inspired Wooden Actuators for Large Scale Applications. *PLOS ONE* 10, 1–16. <https://doi.org/10.1371/journal.pone.0120718>
- Tibbits, S., McKnelly, C., Olguin, C., Dikovskiy, D., Hirsch, S., 2014. 4D Printing and Universal Transformation, in: *ACADIA DESIGN AGENCY*. Presented at the MATERIAL AGENCY.
- Vazquez, E., Randall, C., Duarte, J.P., 2019. Shape-changing architectural skins: a review on materials, design and fabrication strategies and performance analysis. *Journal of Facade Design and Engineering* 91-102 Pages. <https://doi.org/10.7480/JFDE.2019.2.3877>
- Wood, D., Correa, D., Krieg, O., Menges, A., 2016. Material computation—4D timber construction: Towards building-scale hygroscopic actuated, self-constructing timber surfaces. *International Journal of Architectural Computing* 14, 49–62. <https://doi.org/10.1177/1478077115625522>

FROM IMMERSIVE TO PHYSICAL SKETCHES

A new 3D representation mode during ideation

ABDELMOUNEM TAOUAI AND TOMÁS DORTA

Design Research Laboratory Hybridlab, University of Montreal

Email address: abdelmounem.taouai@umontreal.ca

Email address: tomas.dorta@umontreal.ca

Abstract. This paper presents a new representation mode during ideation based on the use of immersive 3D sketches and their digital fabrication. This work explores freehand immersive 3D sketches of design objects printed at real scale. Freehand 3D vectors were optimized thanks to parametric geometries generated for 3D printing. Our approach aims to take advantage of real-scale immersive 3D sketches, while enriching the 3D perception of proportions and shapes by 3D printing the physical sketches. 3D printing usually requires high-level of 3D modeling skills and this can be challenging during ideation. This technique will allow to reduce the steps going from: 2D sketches – 3D modeling – fabrication to 3D sketches – 3D physical sketches. The hybridization of immersive life-size sketching and 3D printed life-sized sketches, could positively impact ideation by allowing a better grasp of the 3D shapes' scales and proportions.

Keywords: 3D physical sketches; immersion; design ideation; fabrication.

ملخص. تقدم هذه الورقة البحثية طريقة عرض جديدة اثناء عملية التفكير، اعتمادا على استعمال الرسم الثلاثي الابعاد الإنغماري وصناعة هذه الرسوم رقميا، هذ البحث يستكشف إمكانات الرسم اليدوي الثلاثي الابعاد في بيئة افتراضية غامرة لتصميم أشياء يمكن طباعتها رقميا بأبعاد حقيقية. الأشكال ثلاثية الاتجاهات المتحصل عليها يدويا سيقع تحسينها بفضل الهندسة البارمترية لطباعتها رقميا. يقوم منهجنا على الاستفادة من الرسم الثلاثي الابعاد حقيقي المقاسات، الإنغماري من جهة، وتعزيز ادراكنا الثلاثي الابعاد للنسب والأشكال عن طريق الطباعة الرقمية لهذه الرسومات بجعلها مادية ملموسة من جهة أخرى. عادة تتطلب تكنولوجيا الطباعة الرقمية ثلاثية الابعاد قدرا عاليا من اتقان النمذجة وهذا يمكن ان يشكل تحديا وعائقا لعملية التفكير. ان التقنية التي نقترحها تمكن من اختزال المراحل ما بين: الرسم الثنائي الابعاد - النمذجة الثلاثية الابعاد - الصناعة، لتصبح المراحل: رسوم ثلاثية الابعاد- رسوم مادية ثلاثة الابعاد. ان تهجين الرسم الثلاثي الابعاد الإنغماري، حقيقي المقاسات والطباعة ثلاثية الابعاد لهذه الرسوم بمقاسات حقيقية، يمكن ان يؤثر إيجابيا على الوعي بمقاسات الأشكال ثلاثية الأبعاد ونسبها.

الكلمات المفتاحية: الرسوم المادية الثلاثية الابعاد، انغمار، تفكير تصميمي، تصنيع.

1. Ideation by representing

Design practice is characterized by using representations like sketches as the embodiment of design intentions. From quick sketches to final prototypes, the designer uses a variety of representations to exteriorize and develop solutions to design problems. Representations are used as essential tools to support the ideation activity (Visser, 2006). Designers use different modes of representation to reflect and reason on design ideas, to clarify these ideas, and to present design intentions to the project's stakeholders (Goldschmidt and Smolkov, 2006). These representations support communication and interaction between various stakeholders in the design process (Schön, 1992). Design intentions are externalized under different modes of representation for the purpose of validating and revising design ideas. During ideation, designers use several mediums acting as triggers of creativity. They use visual representations such as sketches, concept diagrams, plans, sections, elevations, perspectives but these are also usually accompanied by physical models throughout the design process. For examples of representations in industrial design see Figure 1.



Figure 1. Example of design representations to support communication during product development (Pei, Campbell and Evans, 2011).

New digital modes of representation generally aim to simulate traditional representation techniques such as sketches, rendering images and 3D models through new devices and interactions. One such example would be "ILoveSketch" (Bae, Balakrishnan and Singh, 2008), a 3D curve sketching system that captures some of the possibilities of pen sketching, allowing 3D conceptual curve models by changing the point of view on the screen while integrating traditional sketch-based techniques. Immersive representations using Virtual Reality (VR) are also now more present during ideation. We can distinguish three types of VR environments: HMDs combined with

controllers (HTC Vive™), CAVE-like systems (Cruz-Neira et al. 1992) and VR Powerwalls. Using tools of the kind and their respective approaches to 3D sketching (often based on 3D pipes) for immersive design promotes various potentials: increased sense of presence, greater possibility and directedness for evaluating spatial qualities, visualization, simulations and real-scale design (Castronovo et al. 2013).

Fused deposition modeling (FDM) is the more popular form of 3D printing technology where a 3D object is "printed" (built) by adding layer after layer of a particular material. For this, the 3D model of the object has to be decomposed into successive layers that will be printed one by one. The first step in 3D printing is to create a 3D model of the object to be printed. This is usually done with 3D modeling software necessary to create and manipulate 3D objects. This can be done using primitives or more specific 3D generation commands, either using surface modelers or solid modelers. However, these 3D modelers require a certain mastery of their commands and interface to work with the accuracy and three-dimensional grasp needed to ensure the resulting shapes are properly closed (waterproofing). On one hand, during ideation, designers seek speed and spontaneity that they attain through the gestures of freehand sketches. To give an illusion of three-dimensionality, they use several techniques such as perspective views and lighting effects (e.g. renders using shadows), giving some sense of depth to their images. On the other hand, 3D modeling is closer to the work of making the physical object and, to turn sketched design ideas into a physical model through 3D printing, it is essential to go through 3D modeling software. However, going from sketches to 3D modeling-for-3D-printing can negatively impact the initial design idea, because when designers try to "remodel" the sketched idea they need to transform shapes' details to make them 3D printable. Moreover, perspective views can hinder the perception and the understanding of the proposed 3D geometry, and translating 3D objects from perspectives to 3D models isn't a negligible challenge. To avoid these issues, solutions need to be developed to print sketches (this time immersive and in 3D), directly without going through 3D modeling software. In this paper, a new representation approach is proposed through a kind of "hybridization" between immersive sketches and physical sketches. We present the exploration of this method where we have used immersive 3D sketches from a VR system and we 3D printed those sketches. We explored this process automatically without the need of using 3D modeling techniques by the user and 3D printed the sketches at full scale.

2. State of the Art

2.1. TRADITIONAL IDEATION PROCESS:

The first step of the traditional ideation process is based on conventional 2D drawing techniques. Since designers are trained to quickly explore ideas on paper by sketching line drawings in perspective, they use these spontaneous, gestural, and rapid sketches to represent and generate their abstract ideas and to exteriorize, visualize, and interact with their mental images (Kavakli et al. 2001). Qualitative and imprecise 2D sketches remain the most used tool during ideation to represent possible solutions and to reflect in action, considering their relevance to resolve design problems (Schon and Wiggins, 1992). It is also a way to assess ideas and predict whether they are worth exploring further all while making it easier to communicate design intentions to clients and other collaborators. The traditional sketch is a two-dimensional image drawn on a plane: a flat surface, or a screen. In that plane, the 2D image is depicted in XY coordinates, and to give an illusion of three-dimensionality, we can use several techniques such as adding perspective, processing those drawings using shaded rendering to simulate light/shadows and curved surfaces that provide depth effect and volume (see Study Sketch in Figure 1). The third dimension (3D) adds a third coordinate component (Z) which correspond to depth, allowing 3D images to be digitally represented. Also, traditional sketches require mastery of perspectival techniques to successfully represent 3D solutions. Additionally, traditional sketches are scaled (not life-sized) depictions of design artefacts that can affect the perception of their real proportions. In the traditional ideation process, the physical model is considered as another effective tool to represent 3D design ideas and experiment with 3D shapes (see Sketch Model in Figure 1). Handmade models offer the possibility of intervening directly on the materials. This allows decision-making and form validation as well as helps to improve the creative process (Sun et al. 2013). However, mastering sculpting techniques also requires to be skilled if one desires to make realistic models true to the designers' mental image; designers use physical representations mostly when the idea is already selected and finalized. One could also note that respecting the real scale is only possible for relatively medium sized objects.

2.2. DIGITAL IDEATION PROCESS:

The introduction of digital tools during ideation have greatly contributed to reshaping the methods of developing new modes of representation. On one hand, VR provides immersive environments that allow designers to work alone or in teams with full-scale 3D immersive sketches. The use of

FROM IMMERSIVE TO PHYSICAL SKETCHES

immersive environments has shown several advantages, as they improve the understanding of proportions and scales (Tano et al. 2013). It also improves the evaluation of design proposals (Adenauer et al. 2013) and allows a better understanding of the design context (Beaudry-M et al. 2018). But above all, digital tools promote the original role of 3D sketches as a tool for a spontaneous, rapid and dynamic ideation process (Bae, Balakrishnan, and Singh, 2008). Although VR systems can provide a visual immersive experience during the 3D sketching activity, the haptic or psychomotor feedback of tracing the lines and feeling them with the pen is still missing in midair 3D sketching applications, which can also influence the perception and production of volume of the sketched 3D objects. Most of VR systems that allow 3D sketching, such as Gravity Sketch™, in fact offer a kind of 3D modeling by drawing in space (midair) using controllers (Figure 2 left). The brush does not create a line drawing sketch but solid shaded pipes and surfaces in order to cast shadows and to be visible in the VR render engine. Also, they are made using an interface based on tool menus similar to 3D modeling software (using extrusions, boolean operations, etc.), hindering the interaction (with digits, commands, etc.) inside the immersion. For our exploration we selected the Hyve-3D™ system (Dorta, Hoffmann and Kinayoglu, 2016) which allows 3D sketching of 3D polylines curves (3D vectors) by using handheld tablets used as props of a virtual canvas with 6DOF (Figure 2 right). The 3D sketch is made from orthogonal views 2D sketches with more control since they are executed against a solid surface (held tablet) rather than in midair, offering a feedback similar to that of sketching on paper on a table (plan-elevation-side views). To achieve a complex 3D shape, the position of the virtual canvas can be changed to any 3D position (see also Figure 9).

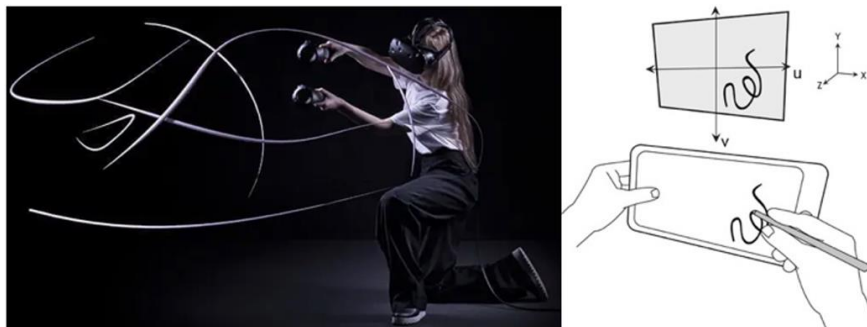

Figure 2. 3D sketching in Gravity Sketch (left); 3D sketching in Hyve-3D (right).

On the other hand, digitally controlled milling (CNC), laser cutting, and 3D printing are becoming cheaper and generally more accessible. As a result, many designers have learned about the benefits and challenges of

using digital manufacturing in their design efforts. The democratization of digital fabrication opens new opportunities for physical representation (Agirbas, 2015). However, 3D printing is often used to represent already designed ideas. Immersive 3D sketches offer the advantage of representing initial ideas at life-size and in real-time, for a better perception of proportions, which remains unattainable with today's physical representation approaches.

3. Explorations of The Proposed Technique

To face the challenge of directly 3D print 3D sketches without going through 3D modeling techniques we first started using Hyve-3D to produce freehand 3D sketches at real scale inside the immersion. We choose three design objects (face mask structure, chair and car). The first activity was to create a personalized mask structure (to improve breathing), drawn directly on a 3D scanned face. This allowed us to validate scale, proportions and the ergonomic quality of the 3D to-be-printed sketch of the mask structure (Figure 3) (time spent: 5 min).

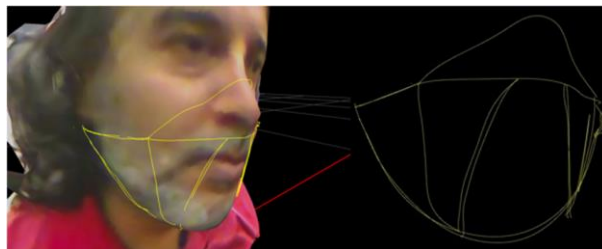

Figure 3. Freehand 3D vectors of the mask directly on a 3D scanned face in Hyve-3D.

FROM IMMERSIVE TO PHYSICAL SKETCHES

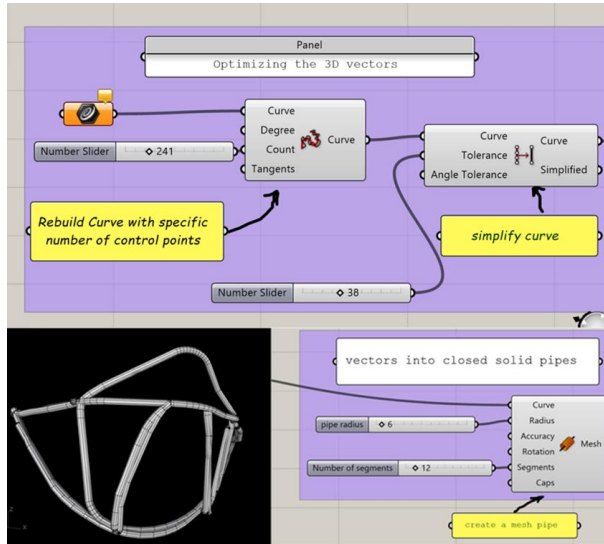

Figure 4. Grasshopper definitions - Optimization of 3D vectors (up) and Convert 3D vector into solid (closed) mesh (down).

We created a Grasshopper™ definition to optimize the 3D polylines. Firstly, we reduced the number of points without deforming the initial design (Figure 4 - up). In the third step we converted these vectors into closed solid pipes (meshes) adding a radius and a number of faces, essential for 3D printing using FDM (Figure 4 - down).

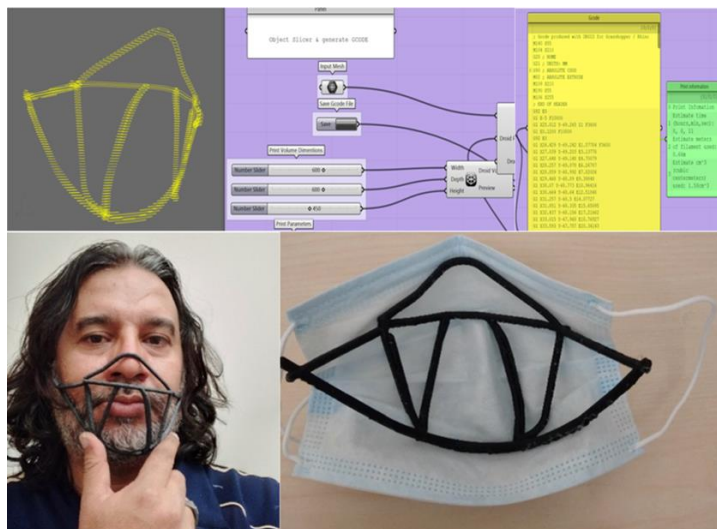

Figure 5. Grasshopper definition to generate a GCODE after solid mesh slicing (up) and Printed 3D mask structure and validation of scale and proportions (down).

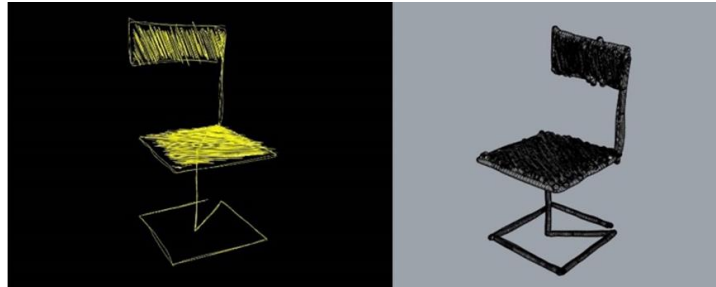

Figure 6. 3D sketch of Flamingo chair in Hyve-3D (right) and the mesh model (left).

The last step is to slice the obtained solid mesh in layers and generate the 3D printing machine language G-CODE (Figure 5 - up). In Figure 5 (down), the printed 3D sketch was validated (scale and proportions) wearing it as a mask structure. The second object was a chair which design concept was to draw it with a single contained line (which we called *Flamingo*). We used some hatching to simulate the backrest and seat (Figure 6).

The third subject was a car (Fiat 500) and we also partially 3D printed at real scale. We 3D printed a part of the car (the left rear lower part) in pieces and assembled them. It was proven that for large pieces this technique requires a lot of time (several weeks for a 40cm FDM printer) and a great effort to assemble the parts (Figure 7). We succeed even to hold the door handle of the car 3D sketched 1/1 (Figure 8).



Figure 7. Freehand 3D sketches in Hyve-3D (3D vectors) (time spent: 4 hours) (left), Printed freehand 3D sketches of the car at 1/10, 1/100 (center), 1/1 scale “partial” (right).



Figure 8. Car door handle (partial) 3D printed at real scale (the chair shows the scale) (left-center), manipulating and touching the model (left).

FROM IMMERSIVE TO PHYSICAL SKETCHES

To compare the 3D sketches made in Hyve-3D and those from another VR system, we 3D printed a face mask designed using Gravity Sketch. Surfaces shapes weren't able to be 3D printed (Figure 9, translucent surface at left) but only the 3D pipes (a form of 3D sketches) (Figure 9, center). It was noted that the shape of the mask was symmetrical and appears closer to a more finalized 3D model shape than an ideation sketch. Figure 9 (left) shows another freehand sketched idea of the mask made in Hyve-3D.



Figure 9. Virtual and real 3D model using Gravity Sketch (left and center); Freehand 3D sketch from Hyve-3D (right).

4. Discussion

This exploratory approach allowed us to reveal several advantages of 3D printing directly from Hyve-3D's 3D sketches. In fact, it allowed us to obtain a kind of transparent "printed wireframe object" which offers a new possibility to experience the volumes and qualities of design ideas through shapes and structures different then when handling solid mockups. We also explored to fill some surfaces of an object (the seat of the Flamingo chair) by filling it with hatch lines. The result obtained after conversion into 3D pipes, offered new aesthetic aspects different from an accurate 3D modeled object (Figure 10).



Figure 10. Aesthetic effect of 3D printed hatches for surface filling (seat of Flamingo chair).

Besides being a very powerful tool for practiced designers, this tool also could provide a great promise for design teaching as it allows students to instantly draw 3D shapes and make them physical without any traditional 3D

printing requirements. To progress further in this technique, this exploration will include more efficient 3D printing using a robot arm and a large format extruder head. Future work will analyze the impact of this new ideation representation mode *the printed 3D sketch* on the ideation process, including different audiences (fresh and experienced designers) and involving different design themes. Moreover, even if the automatization using Grasshopper description uses several 3D modeling techniques, our approach could help to really democratize 3D printing for design proposes since 3D modeling skills are no more necessary to feed 3D printers with accurate 3D geometries.

5. Conclusion

An exploratory approach was carried out in which rough freehand 3D sketches were 3D printed as a new representation mode during ideation. VR can be a useful tool to go from 3D sketched ideas to the fabrication of this ideas as physical representations. The transition from an immersive sketch to a physical sketch without using any 3D modeling software is now possible especially with VR systems like Hyve-3D that offer the possibility of creating 3D vectors instead of 3D pipes as sketches. In future studies, we will also consider analyzing the cognitive impact of this representation mode of physical life-sized 3D sketches during ideation.

References

- ADENAUER, J., ISRAEL, J. H., AND STARK, R., 2012. Virtual Reality Technologies for Creative Design. In A. Chakrabarti (Ed.), *CIRP Design 2012*, Springer, 125–135.
- AGIRBAS, A., 2015. The Use of Digital Fabrication as a Sketching Tool in the Architectural Design Process, A Case Study. In B. Martens et al. [Ed.] *Proceedings of eCAADe 2015*, Vienna, Austria, 319-324.
- BAE, S.-H., BALAKRISHNAN R., AND SINGH, K., 2008. ILoveSketch: As-Natural-as-Possible Sketching System for Creating 3d Curve Models. In *Proceedings of UIST '08*. Monterey, CA, 151-160.
- BEAUDRY-MARCHAND, E., DORTA T. AND PIERINI D., 2018. Influence of Immersive Contextual Environments on Collaborative Ideation Cognition - Through Design Conversations, Gestures and Sketches. In Kepczynska-Walczak, A, Bialkowski, S (Eds.), *Computing for a Better Tomorrow – eCAADe '18 - Volume 2*, Lodz, Poland, 795-804.
- CASTRONOVO, F., NIKOLIC, D., LIU, Y. AND MESSNER, J., 2013. An evaluation of immersive virtual reality systems for design reviews. In: N. Dawood and M. Kassem (Eds.), *Proceedings of the 13th International Conference on Construction Applications of Virtual Reality*, London, UK, 30-31.
- CRUZ-NEIRA, C., D. J. SANDIN, T. DEFANTI, R. V. KENYON, AND HART, J. C., 1992. The CAVE: Audio Visual Experience Automatic Virtual Environment. *Communications of the ACM* 35 (6): 64-72.

FROM IMMERSIVE TO PHYSICAL SKETCHES

- DORTA T., KINAYOGLU G. AND HOFFMANN M., 2016. Hyve-3D and the 3D Cursor: Architectural co-design with freedom in Virtual Reality. *International Journal of Architectural Computing*, 14 (2): 87-102.
- GOLDSCHMIDT, G., AND SMOLKOV, M., 2006. Variances in the Impact of Visual Stimuli on Design Problem Solving Performance. *Design Studies* 27: 549-69.
- KAVAKLI, M., SUWA, M., GERO J., AND PURCELL. J.S., 2001. Sketching Interpretation In Novice And Expert Designers. In Gero, J.S. and Tversky, B. (Eds.), *Visual and Spatial Reasoning in Design*, Key Centre of Design Computing and Cognition, University of Sydney, Australia, 209-220.
- PEI, E., CAMPBELL, I., AND EVANS, M., 2011. A Taxonomic Classification of Visual Design Representations Used by Industrial Designers and Engineering Designers. *The Design Journal*, 14(1), 64-91.
- SCHÖN, D. A. 1992. Designing as Reflective Conversation with the Materials of a Design Situation. *Research and Engineering Design*, 3 (3): 3-14.
- SCHÖN, D. A., AND WIGGINS. G., 1992. Kinds of Seeing and Their Functions in Designing. *Design Studies* 13(2): 135-56.
- SUN, L., FUKUDA T., TOKUHARA T., AND YABUKI, N., 2013. Difference Between a Physical Model and a Virtual Environment as Regards Perception of Scale. In R. Stouffs et al. (Eds.), *Open Systems: Proceedings of CAADRIA 2013*, 457-466.
- TANO, S., S. YAMAMOTO, J. ICHINO, T. HASHIYAMA, AND IWATA, M., 2013. Truly Useful 3D Drawing System for Professional Designer by 'Life-Sized and Operable' Feature and New Interaction. In P. Kotzé et al. (Eds.) *INTERACT 2013, Part I*. Springer. 37-55.
- VISSER, W. 2006. Designing as Construction of Representations: A Dynamic Viewpoint in Cognitive Design Research. *Human-Computer Interaction* 21 (1): 103-52.

AUGMENTING PASSIVE ACTUATION OF HYGROMORPHIC SKINS IN DESERT CLIMATES

Learning from Thorny Devil Lizard Skins

ZEYAD ALY

*Arab Academy for Science, Technology and Maritime Transport
ziadramly@gmail.com*

ALY IBRAHIM

*American University in Cairo
aly_magdy@aucegypt.edu*

AND

SHERIF ABDELMOHSEN

*American University in Cairo
sherifmorad@aucegypt.edu*

Abstract. The exploitation of latent properties of natural materials such as wood in the passive actuation of adaptive building skins is of growing interest due to their added value as a low-cost and low-energy approach. The control of wood response behavior is typically conducted via physical experiments and numerical simulations that explore the impact of hygroscopic design parameters. Desert climates however suffer from water scarcity and high temperatures. Complementary mechanisms are needed to provide sufficient sources of water for effective hygroscopic operation. This paper aims to exploit such mechanisms, with specific focus on thorny devil lizard skins whose microstructure surface properties allow for maximum humidity absorption. We put forward that this process enhances hygroscopic-based passive actuation systems and their adaptation to both humidity and temperature in desert climates. Specific parameters and rules are deduced based on the lizard skin properties. Physical experiments are conducted to observe different actuation mechanisms. These mechanisms are recorded, and texture and bending morphologies are modeled for adaptive skins using Grasshopper.

Keywords: *Hygroscopic wood properties, passive actuation, programmable materials, hygromorphic skins.*

AUGMENTING PASSIVE ACTUATION OF HYGROMORPHIC SKINS IN DESERT CLIMATES: LEARNING FROM THORNY DEVIL LIZARD SKINS

ملخص. يعد استغلال الخصائص الكامنة للمواد الطبيعية مثل الأخشاب في التشغيل السلبي لواجهات المباني التكيفية ذا أهمية متزايدة وذلك لقيمتها المضافة كمنهج منخفض التكلفة والطاقة. ويتم عادة إجراء عمليات التحكم في سلوك استجابة الأخشاب من خلال تجارب مادية ومحاكاة عددية تعمل على استكشاف تأثير معاملات التصميم الاسترطابي. على الوجه الآخر، تعاني المناخات الصحراوية من ندرة المياه وارتفاع درجات الحرارة، مما يستدعي آليات تكيفية لتوفير مصادر كافية للمياه من أجل عملية استرطابية فعالة. تهدف هذه الورقة البحثية إلى استغلال تلك الآليات مع التركيز بشكل خاص على جلد السحلية الشائكة والتي تسمح خصائص سطحه المجهرى بأقصى درجات امتصاص الرطوبة. وتطرح الورقة البحثية أن عملية الامتصاص تلك تعزز من أنظمة التشغيل السلبي القائمة على الرطوبة وتكيفها مع كل من الرطوبة والحرارة في المناخات الصحراوية. تم استنتاج مجموعة من المعايير والقواعد المحددة بناءً على خصائص جلد السحلية الشائكة وإجراء تجارب مادية لمراقبة آليات التشغيل المختلفة، ثم تسجيل هذه الآليات وتصميم تشكلات مرتبطة بخصائص ملمس السطح والانحناء للواجهات التكيفية باستخدام برنامج جراسهوبر.

الكلمات المفتاحية: الخصائص الاسترطابية للخشب، التشغيل السلبي للمواد، المواد المبرمجة، أغشية المباني المعتمدة على الخصائص الاسترطابية.

1. Introduction

Architects have continually mimicked reactive objects from nature to utilize their behavioral properties in the heterogeneous structure of materials. The research area at the intersection of building technology and materials science in architecture has helped introduce material composites as a manipulated substance. Micro-scale systems can now be considered as information which can be analysed (Ahlquist & Menges, 2011). Nature has introduced multiple opportunities in designing and generating novel shape shifting mechanisms that are obtained by an expressive transformation through an ecological manner. Nature can originate structural materials to assist in the making of deformable and formative motions. Three main factors have been noted in the literature as being essential for transformation: (1) material physicality (being soft or hard), (2) forces as energy for motion, both internal and external, that reactivate materials, and (3) information that guides the instruction of transformation (Ou, 2014). This paper exploits the latent properties of materials based on the exploration of behavioral properties of living organisms, specifically the thorny devil lizard skin.

1.1. HYGROSCOPIC BEHAVIOR OF WOOD

The capability of wood to absorb and retain moisture content relies primarily on the orthotropic nature of wood, where its mechanical properties vary based on the direction of timber axes. These response variations are captured to develop a controlled passive actuation and programmability logic for adaptive skins. The material ability of moisture absorption and desorption

due to transformations in humidity levels in the surrounded environment is known as its hygroscopic properties. Moisture penetrates inside the composite tissues, and its percentage is determined through calculating the difference between the weight of wood at dry and wet status. The maximum absorption behavior reaches the fiber saturation point (FSP), then any extra moisture is stored in cell cavities which slightly impact mechanical characteristics of timber compared to the absorbed one.

Shape shifting typically occurs in anisotropic materials across longitudinal shrinkages, tangential to rising rings, or radial stretching (Holstov et al., 2015; Krieg, 2014; Ruggerberg and Burgert, 2015; Wood et al., 2018).

Wood is a natural hygromorphic material. By increasing relative humidity, the wood moisture transfers in the wood to achieve equilibrium (Huinink, 2017). Advanced technologies and improved processing forming have been widely developed recently in the use of wood (Bechthold & Weaver, 2017). Architectural conceptualizations that attempt to capture the richness of wood as a natural material have been continually utilizing the advanced computer aided design and computer aided manufacturing techniques and tools in diverse fields like engineering, construction and material sciences (Krieg, 2014). Wood is one of the typically utilized building materials nowadays due to its homogenous structural composition and standardization, and the advantage of being a naturally produced, sustainable, and energy efficient construction material. The energy consumption of wood is approximately 50 times less than that of steel (Menges, 2010).

The hygroscopic swelling and shrinking process in wood mimics the behavior of plants that use a moisture-driven mechanism to change form. Plant cells are hydrophilic in nature where when subjected to a dry environment shrink in volume due to evaporation. The gradual opening and closing of pinecones takes place for example due to changes in relative humidity based on their dynamic bilayer structure. The external layer of the tissue acts as an active layer. It reacts closely with parallel thickened cells by longitudinally expanding when exposed to humidity and shrinking after drying. The internal layer acts as a passive layer that does not react as strongly, as shown in Figure 1 (Holstov et al., 2015).

The control of wood response behavior is typically conducted through physical experiments and numerical simulations that explore the impact of hygroscopic design parameters like grain orientation, type of wood, sample thickness, dimensional ratio, and lamination. These parameters typically affect both response speed and motion type, such as bending, twisting, and folding. Wood in that sense acts as both a sensor and actuator, as it senses variations in humidity and responds accordingly with different morphological transformations.

As this hygroscopic property mostly only occurs in humid environments with high fluctuations in relative humidity, it was important to seek

AUGMENTING PASSIVE ACTUATION OF HYGROMORPHIC SKINS IN DESERT CLIMATES: LEARNING FROM THORNY DEVIL LIZARD SKINS

additional inspirations that would presumably work for arid environments. The next section sheds light on the capabilities of thorny devil lizard skins as an inspiration for hot arid environments, the premise being augmenting the passive actuation enabled by the hygroscopic properties of wood.

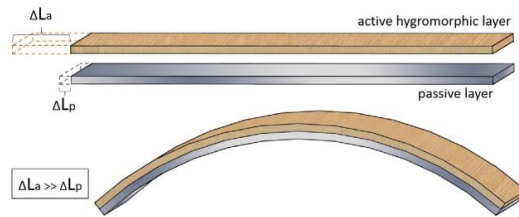

Figure 1. Responsiveness principles of hygromorphic composites in wood based on differential hygro-expansions of active and passive layers (Holstov et al., 2015).

1.2. THORNY DEVIL LIZARD AS AN INSPIRATION

Desert climates typically suffer from water scarcity and high temperatures. For an adaptive skin utilizing hygromorphic principles to properly function in such climatic zones, complementary mechanisms are needed to cater for sufficient sources of water for the hygroscopic effect to work. In this section, we exploit such mechanisms, with specific focus on thorny devil lizard skins (Sherbrooke, 2004; Comanns et al., 2015). The microstructure surface properties of these skins allow for maximum humidity absorption. The skin scales contain channels that collect water using capillarity sensing. We put forward that this absorption would enhance hygroscopic-based passive actuation systems and their ability to adapt via a programmable mechanism to different stimuli of humidity and temperature in desert climates.

Lizards can inhabit arid environments presumably in part because of their ability to collect water on their skins when drinking water is inaccessible (Comanns, 2011; PC, 1993). The Australian thorny devil (Agamidae: *Moloch horridus*) and the Texas horned lizard (Iguanidae: *Phrynosoma cornutum*) for instance have a unique ability to harvest environmental moisture (Pianka, 1975). Their skins also can collect water after rain fall, in a phenomenon known as ‘water absorption’ (PA, 1923; HW, 1923), ‘blotting paper effect’ (Bentley, 1962) and ‘rain harvesting’ (WC, 2004).

‘Moisture harvesting’ is perhaps the most appropriate term, as it comprehensively describes the different kinds of water acquisition (Comanns, 2011). Such systems have interesting biomimetic implications. Accordingly, biomimetic studies of these lizards are invaluable, with respect to adapting biological mechanisms for anthropological roles of water acquisition for surface wettability and directional liquid transport (Comanns,

2011; Comanns, 2014), sampling/collection of target material for detection systems (Biggins, 2008), or lubrication (Comanns, 2015). The physical ability of thorny devils and horned lizards to harvest moisture is apparently acquired by their inability to drink directly, reflecting their oral and lingual adaptations for eating small ants (Pianka, 1970; CE, 1928; Whitford, 1979). Water collection is enabled by the role of small skin channels between the scales that accumulate water. The integument of desert lizards is substantially waterproof to minimize water loss by evaporation (Comanns, 2017). The thorny devil lizard has a Voronoi cellular skin as a basic 2D pattern. In 3D, the cells overlap creating a shaded area forming small skin channels (capillary channels) where the moisture harvesting effect occurs between the scales that accumulate water. Figures 2, 3 and 4 illustrate the skin morphology, capillary water transport and protrusions in capillary channels of the *Moloch horridus* desert lizard.

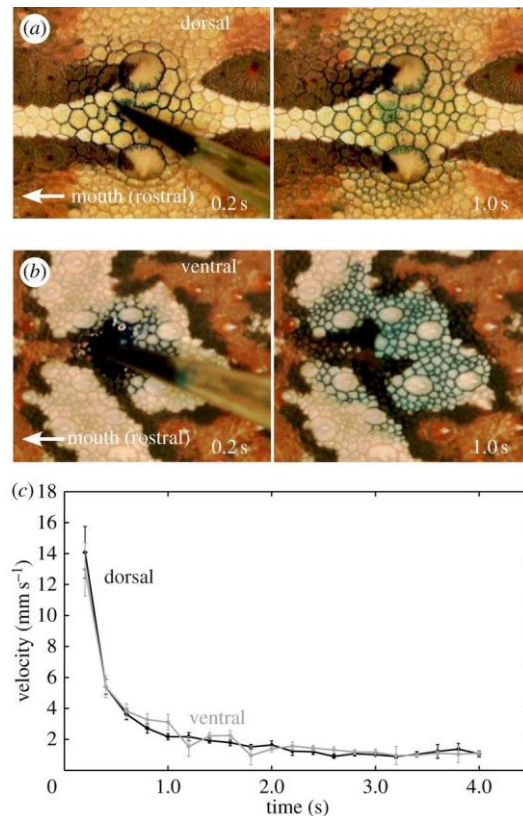

Figure 2. Capillary water transport of 7µl droplets on the *Moloch horridus* skin: (a) Dorsal surface, (b) Ventral surface, (c) Velocity on different body sides. (Comanns, 2017)

AUGMENTING PASSIVE ACTUATION OF HYGROMORPHIC SKINS IN DESERT CLIMATES: LEARNING FROM THORNY DEVIL LIZARD SKINS

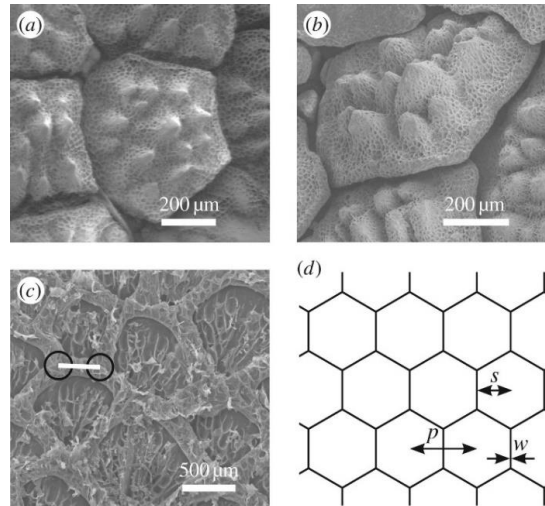

Figure 3. Skin morphology of *Moloch horridus* with capillary channels in between the scales: (a) Dorsal scale topography by SEM imaging, (b) Overlapping of dorsal scales, (c) Inner side of ventral exuviae. The length of capillaries (white bar) determined as mean distance between intersection points with two other capillaries (geometric centre of black circle placed in intersection area), (d) Scheme of hexagonal capillary network structure. The values for modelling are indicated; pitch p , scale radius s , width of channel w . (Comanns, 2017).

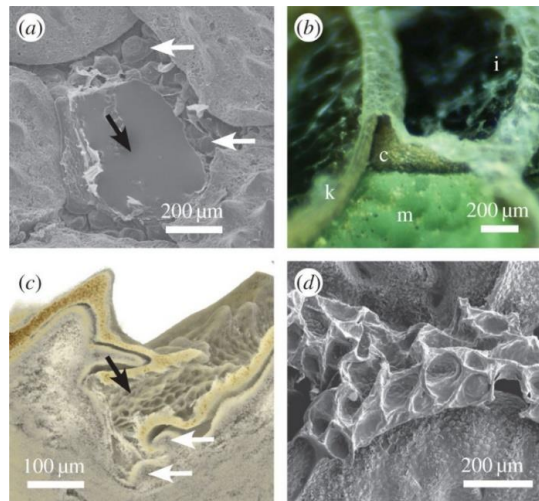

Figure 4. Protrusions in capillary channels of *Moloch horridus*: (a) Top view of channels surrounding removed scale (black arrow). Protrusions (white arrows) reach into the channel cavity, (b) Light microscopy of shed skin on casting material (m). The channel cavity (c) formed by a thin keratin layer (k) of the exuviae is well preserved. Orientation of exuviae is indicated by inner side (i), (c) Cross section through skin using μ CT., (d) SEM imaging of skin cast from ventral side, i.e. negative form of skin channel topology (Comanns, 2017).

2. Methodology and Experiment Setup

Based on the observations of the skin properties of the *Moloch horridus* lizard, we selected two materials for testing that were seen to mimic the behavior of water retention from the external environment: silica gel and potassium chloride. The premise was to develop experiments to compare the response behavior of a single layer of wood veneer (Beech veneer) to fluctuation of humidity levels with two laminated samples or composites: (1) silica gel and Beech veneer composite, and (2) potassium chloride and Beech veneer composite. Both materials were isolated from one side. The assumption was that each of the composites would retain humidity and release moisture while increasing the temperature conditions. We used a humidity chamber including a humidifier and a de-humidifier to test the reaction and deflection of samples of each of the tested composites. We then tested multiple material samples to track the shape shifting behavior and angle of deflection for each sample (Abdelmohsen, et al., 2018). The main components used for such an experiment were a humidifier, dehumidifier, wood veneer samples, camera, humidity/ temperature meter, glue, silica gel composite, and potassium chloride composite (Figure 5).

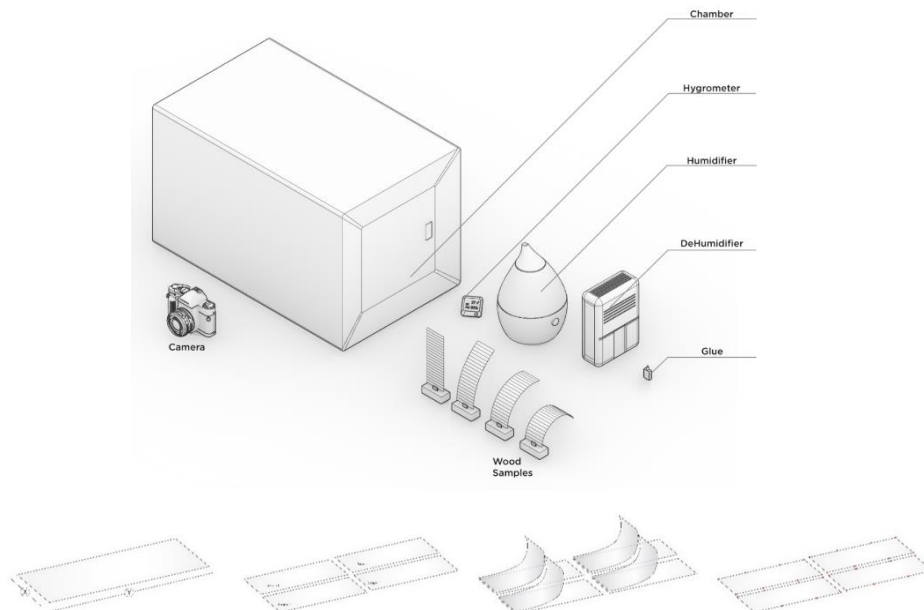

Figure 5. Experiment setup and wood lamination with silica gel and potassium chloride

The process and steps of the experiments was initiated by placing the selected layers inside the humidity chamber while applying a specific condition using the humidifier and de-humidifier. During the experiment, a

AUGMENTING PASSIVE ACTUATION OF HYGROMORPHIC SKINS IN DESERT CLIMATES: LEARNING FROM THORNY DEVIL LIZARD SKINS

temperature/hygro-meter was used to document response time, temperature, and humidity (Table 1).

TABLE 1. Sample composites used in the experiments (Silica gel/ Beech veneer composite, potassium chloride / Beech veneer composite, and single Beech veneer layer)

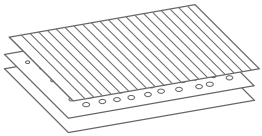
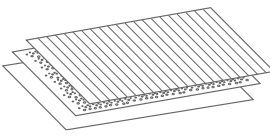
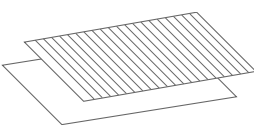
Laminated - Silica Gel	Laminated - Potassium Chloride	Single layer of veneer
		
<p>Silica gel composite acts as a retainer of humidity from the environment and releases moisture while increasing the temperature level with a single layer isolated from one side</p>	<p>Potassium Chloride composite acts as a retainer of humidity from the environment and releases moisture while increasing the temperature level with a single layer isolated from one side</p>	<p>Single layer of Beech veneer isolated from one side</p>

3. Experiment Observations and Results

The following five experiments were conducted, with varying conditions of relative humidity and temperature. In Experiment 1, three selected samples with different material composites (Laminated silica gel and Beech veneer sample, laminated potassium chloride / Beech veneer sample, and a single Beech veneer layer sample) were tested under normal temperature and average relative humidity of 47%. The main observations are illustrated in Figure 6.

It was observed in this experiment that the Silica gel composite acts as a retainer of humidity gained from the surrounded environment and reacts rapidly with the highest maximum deflection (6.82mm). The Potassium chloride composite acts as a retainer of humidity and reacts gradually with a maximum deflection of 1.35mm. The single layer of Beech veneer reacts to the surrounded humidity with minimal deflection, recorded at 0mm.

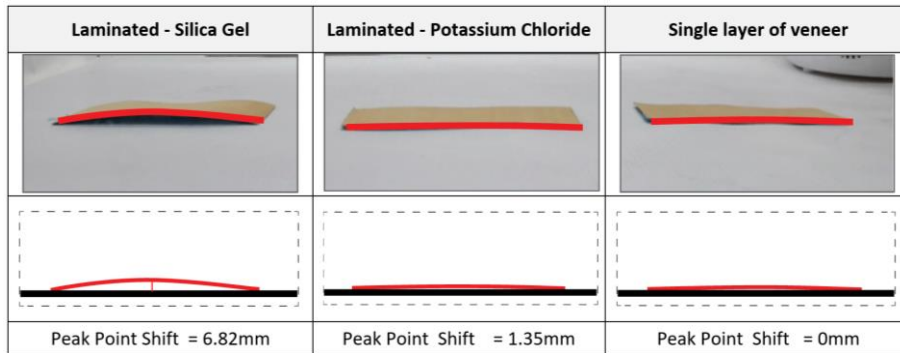

Figure 6. Deflection results for experiment 1 (composite laminated with silica gel, composite laminated with potassium chloride, and single Beech wood veneer) under normal temperature conditions and average relative humidity 47%.

In Experiment 2, the three selected samples with different material composites (Laminated silica gel and Beech veneer sample, laminated potassium chloride / Beech veneer sample, and a single Beech veneer layer sample) were tested under normal temperature conditions and increased humidity level. The temperature was 25.7°C, while the relative humidity was increased to 47%. Figure 7 shows the results observed after 3 minutes.

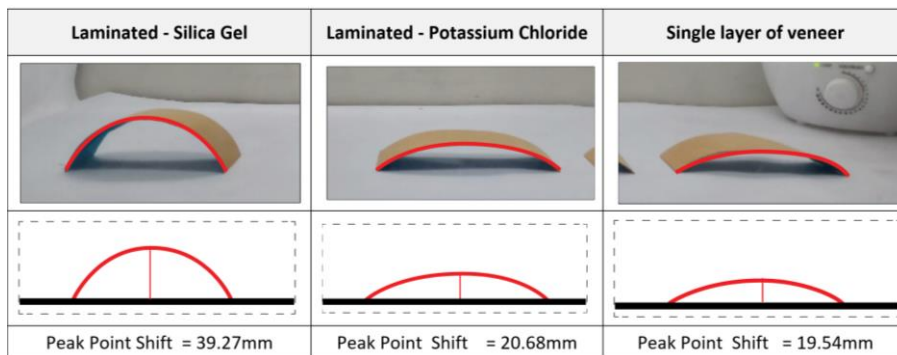

Figure 7. Deflection results for experiment 2 (composite laminated with silica gel, composite laminated with potassium chloride, and single Beech wood veneer) under normal temperature conditions (25.7°C) and increasing relative humidity (increased to 47%).

It was observed that the laminated silica gel sample reacts rapidly with the highest deflection (39.27mm). The potassium chloride composite reacts gradually with constant speed with a maximum deflection of 20.68mm. The single Beech veneer layer reacts with a maximum deflection of 19.54mm.

AUGMENTING PASSIVE ACTUATION OF HYGROMORPHIC SKINS IN DESERT CLIMATES: LEARNING FROM THORNY DEVIL LIZARD SKINS

In Experiment 3, the three selected samples with different material composites (Laminated silica gel and Beech veneer sample, laminated potassium chloride / Beech veneer sample, and a single Beech veneer layer sample) were tested under room temperature and increasing the humidity level. The temperature was 24.2°C and the relative humidity was increased to 84%. Figure 8 shows the results observed after 7 minutes.





Laminated - Silica Gel	Laminated - Potassium Chloride	Single layer of veneer
		
		
Peak Point Shift = 52.08mm	Peak Point Shift = 48.75mm	Peak Point Shift = 49.76mm

Figure 8. Deflection results for experiment 3 (composite laminated with silica gel, composite laminated with potassium chloride, and single Beech wood veneer) under normal temperature conditions (24.2°C) and increasing relative humidity (increased to 84%).

It was observed that the laminated silica gel sample reached its maximum deflection peak point (52.08mm) before the other samples. The potassium chloride sample reached its maximum deflection at a constant speed with a deflection of 48.75mm. The single Beech veneer sample reached its maximum deflection at a constant speed with a deflection of 49.76mm.

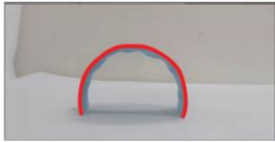
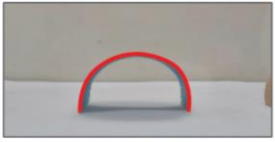
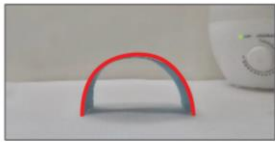
In Experiment 4, the three selected samples with different material composites (Laminated silica gel and Beech veneer sample, laminated potassium chloride / Beech veneer sample, and a single Beech veneer layer sample) were tested under room temperature level while decreasing the humidity level. The temperature was 24.5°C and the relative humidity was decreased to 57%. Figure 9 shows the results observed after 65 minutes.

It was observed that the silica gel sample returned to its normal phase while decreasing the humidity level with a maximum deflection of 5.41mm. The potassium chloride sample retained moisture during decreasing the humidity level and reached a maximum deflection of 27.43mm. The single layer Beech veneer sample returned to its normal state while decreasing the humidity level (0mm deflection).

In Experiment 5, the selected samples (Laminated silica gel and Beech veneer sample, laminated potassium chloride / Beech veneer sample, and a single Beech veneer layer sample) were tested under room temperature and decreasing humidity.

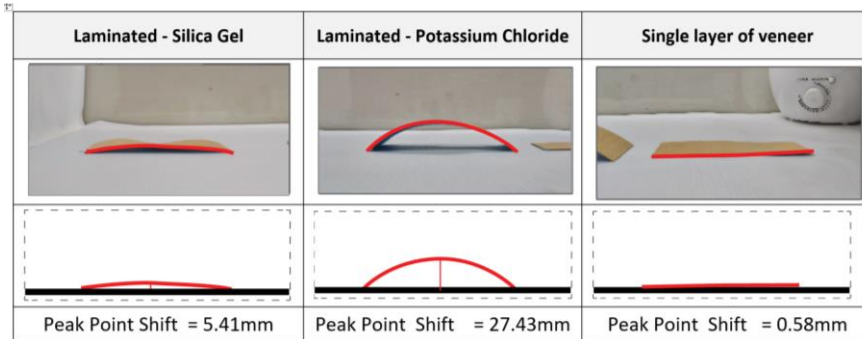

Figure 9. Deflection results for experiment 4 (composite laminated with silica gel, composite laminated with potassium chloride, and single Beech wood veneer) under normal temperature conditions (24.5°C) and decreasing relative humidity (decreased to 57%).

The temperature was 24.6°C, while the relative humidity was decreased to 54%. Figure 10 shows the results observed after 81 minutes. The Silica gel sample stayed mostly constant during the low level of humidity (at maximum deflection of 5.39mm). The potassium chloride sample reversed bending slowly with a deflection of 22.44mm. The single Beech layer was constant during the low level of humidity (at 0mm).

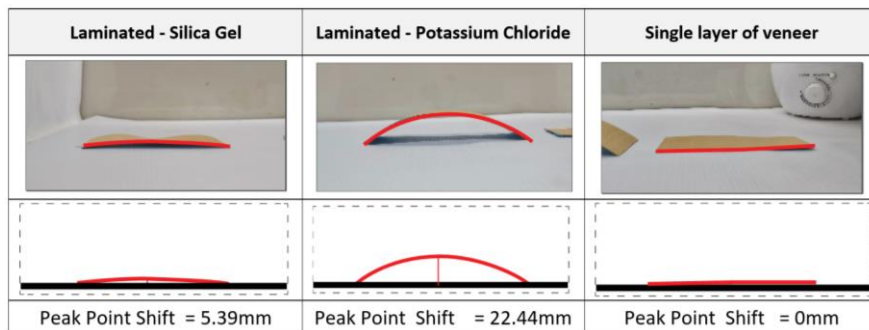

Figure 10. Deflection results for experiment 5 (composite laminated with silica gel, composite laminated with potassium chloride, and single Beech veneer) under normal temperature (24.6°C) and decreasing relative humidity (decreased to 54%).

Discussion

From the observations in each of the five experiments, it can be inferred that the first sample (which consisted of three layers: Beech wood veneer, silica gel and an insulation layer) reacts rapidly to fluctuations in humidity levels due to the chemical properties of silica gel in terms of moisture absorption

AUGMENTING PASSIVE ACTUATION OF HYGROMORPHIC SKINS IN DESERT CLIMATES: LEARNING FROM THORNY DEVIL LIZARD SKINS

and its ability to retain moisture from the surrounded environment. This sample also exhibited the highest deflection and highest response speed upon increase in humidity. In addition, it also returned to its initial state upon decrease in humidity at the highest response speed compared to the base case with Beech wood veneer. This is a significant feature that allows for achieving high deflection and bending mechanisms with a high degree of reversibility.

The second sample (which consisted of three layers: Beech wood veneer, potassium chloride, and an insulation layer) reacted normally to humidity and shifted gradually. The composite retained moisture for a longer time compared to the base case with Beech wood veneer, and so it could maintain specific bending mechanisms for at least 60 minutes in cases. This is also a significant feature that allows for control and regulation of certain bending mechanisms and maintaining morphological transformations for a controlled time duration. These two features further emphasize the added value of the chemical composition of the added materials to the hygromorphic behavior and passive actuation of adaptive systems.

As a prototype, we used Grasshopper to model a unit in an adaptive building skin based on the properties of the thorny devil lizard skin. Based on the findings above, we created a 3D model of a composite sample to be digitally fabricated using either additive or subtractive manufacturing. The sample was meant to not only mimic the thorny devil lizard skin texture, but also demonstrate bending upon fabrication, as shown in figure 11.

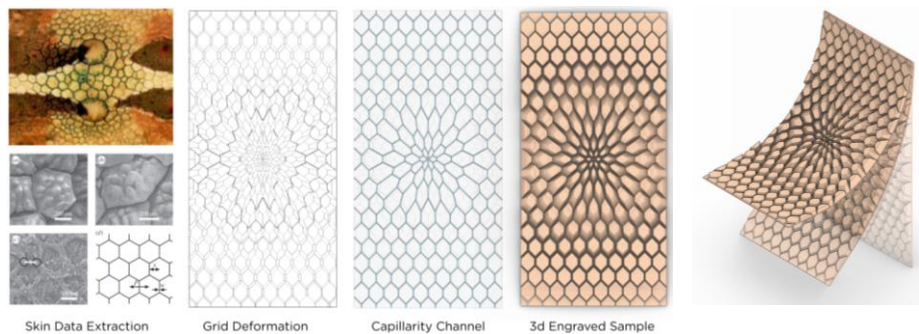

Figure 11. Deriving the surface texture of the adaptive façade prototype and demonstrating its bending properties based on mimicking the thorny devil lizard skin.

The composite comprised the following layers: (a) a layer of fabricated wood with perforations acting as humidity capillary channels for propagation and penetration through the unit, (b) a layer of potassium chloride composite for regulating the bending mechanism and speed as desired, and (c) a layer of wood Beech veneer as a base (Figure 12).

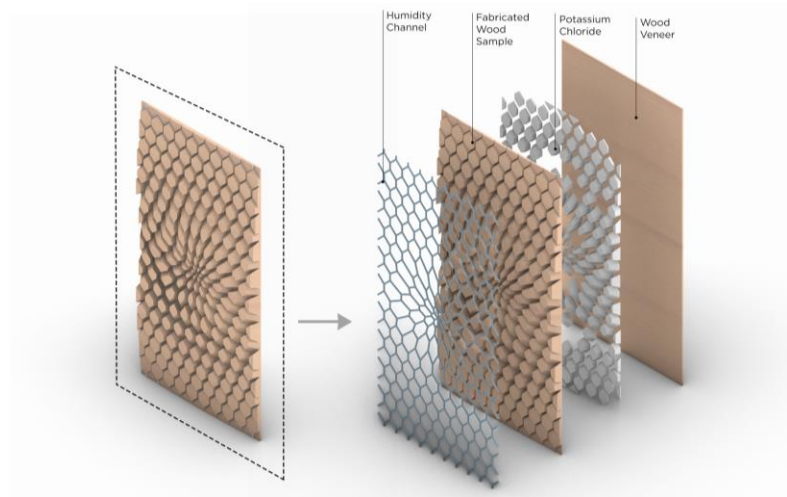

Figure 12. An adaptive façade prototype modelled based on the derived properties.

Future work will focus on including a wider range of experiments and cases of fluctuation in specific intervals of humidity levels and temperature conditions for both composites, and addressing the resulting morphologies while varying the embedded and controlled parameters of wood veneer as a catalyst for active motion, including varying grain orientation, thickness, dimensional ratio, isolation and fixation of partial sample segments.

Conclusion

This paper aimed to develop skin morphologies utilizing programmable passive actuation for building façade adaptivity. Hygromorphic materials like wood typically exhibit various deformation patterns based on a variety of embedded and controlled parameters that affect actuation mechanisms. This paper augments these mechanisms by mimicking properties of water retention in thorny devil lizards for a considerable duration. The study introduced two laminated composites that mimic this behavior in wood composites based on chemical properties: silica gel and potassium chloride. Based on a series of experiments, the deflection of these composites was tested. Findings confirmed that the silica gel composite acts as humidity retainer with high deflection and speed values, while the potassium chloride composite demonstrated retention of fixed morphologies for a long duration. A façade prototype was modeled using Grasshopper to demonstrate surface texture and bending morphologies based on the derived properties.

AUGMENTING PASSIVE ACTUATION OF HYGROMORPHIC SKINS IN DESERT CLIMATES: LEARNING FROM THORNY DEVIL LIZARD SKINS

References

- ABDELMOHSEN, S., MASSOUD, P., EL-DABAA, R., IBRAHIM, A., & MOKBEL, T. 2018. A Computational Method for Tracking the Hygroscopic Motion of Wood to develop Adaptive Architectural Skins. *Material Studies - Volume 2*. Lodz: eCAADe 36.
- AHLQUIST, S., & MENGES, A. 2011. Frameworks for Computational Design of Textile Micro-Architectures and Material Behavior in Forming Complex Force-Active Structures. *Computational Design Thinking*.
- BADRAKIA, H. C. 2015. Performance Review of Aqueous Calcium Chloride Liquid Desiccant Based Air Dehumidifier for HVAC Applications : A Review. *International Journal of Advance Research in Engineering, Science & Technology*, 2(12), 38-50.
- BECHTHOLD, M., & C. WEAVER, J. 2017. Materials science and architecture. *Nature Reviews | Material Volume 2*.
- BENTLEY P.J. 1962. Up take of water by the lizard, *Moloch horridus*. In *Nature* 4829 (pp. 699–700).
- BIGGINS P.D 2008. Bio-inspired approaches to sensing for defence and security applications. In *Analyst* 133 (pp. 563–570).
- CE, B. (1928). Insect food of Kansas lizards with notes on feeding habits. In *J.Kans.Entomol.Soc.1* (pp. 50–68).
- COMANNS, P., BUCHBERGER, G., BUCHSBAUM, A., BAUMGARTNER, R., KOGLER, A., BAUER, S., BAUMGARTNER, W., 2015. Directional, passive liquid transport: the Texas horned lizard as a model for a biomimetic 'liquid diode'. *Journal of the Royal Society Interface*, 12.
- COMANNS P, (2011). Moisture harvesting and water transport through specialized micro-structures on the integument of lizards. In *Beilstein J. Nanotechnol* (pp. 204–214). Retrieved from (doi:10.3762/bjnano.2.24)
- COMANNS P, (2017). *Adsorption and movement of water by skin of the Australian thorny devil (Agamidae:Moloch horridus)*. royal society. Retrieved from <http://dx.doi.org/10.1098/rsos.170591>
- COMANNS P, (2014). Laser-based biomimetic functionalization of surfaces : from moisture harvesting lizards to specific fluid transport systems. In *Int.J.Des.Nat.Ecodyn.9* (pp. 206–215).
- ELGHAZI, Y. S., HAMZA, N., & ROBERTSON, M. D. (2017). Responsive Plant-inspired skins: A review. *Design to thrive*. Edinburgh: PLEA 2017.
- HOLSTOV, A., BRIDGENS, B. AND FARMER, G., 2015. Hygromorphic materials for sustainable responsive architecture. *Construction and Building Materials*, 98, 570–582.
- HUININK, T. A. (2017). Hygromorphic response dynamics of oak: towards accelerated material characterization. *Materials and Structures*.
- HW, D. (1923). The moloch lizard, *Moloch horridus*. In *Vic. Nat.* 40 (pp. 58-60).
- KRIEG, O. D., CHRISTIAN, Z., ZULUAGA, D. C., MENGES, A., REICHERT, S., MENGES, A. (2010). Material Information: Integrating Material Characteristics and Behavior in Computational Design for Performative Wood Construction. *ACADIA2010 life in:forma*. Germany, United States.
- OU, J. (2014). *Material Transformation. Designing Shape Changing Interfaces Enabled by Programmable Material Anisotropy*. Massachusetts: Massachusetts Institute of Technology.
- PA, B. (1923). a study of the fauna in relation to the environment. In *Animallifeindeserts* (p. 176). london.
- PC, W. (1993). Cutaneous water acquisition by the Thorny Devil (*Moloch horridus*, Agamidae). In *Herpetol* (pp. 265–270).
- PIANKA, ER (1970). *The ecology of moloch horridus*. australia. Retrieved from (doi:10.2307/1441978)
- PIANKA, ER (1975). Ecology of horned lizards. In *Phrynosoma platyrhinos* (pp. 141-162). Retrieved from (doi:10.2307/1442418)

- RINDERSPACHER, K. AND SCHWINN, T., 2014. HygroSkin – meteorosensitive pavilion. Fabricate 2014. Negotiating Design and Making, Zurich, 61–67.
- REICHERT, A. M. (2014). Meteorosensitive architecture: Biomimetic building skins based on materially embedded and hygroscopically enabled responsiveness. *Computer-Aided Design*.
- RÜGGEBERG, M. AND BURGERT, I., 2015. Bio-inspired wooden actuators for large scale applications. *PLoS One*, 10(4), e0120718.
- SHERBROOKE, W., 2004. Integumental water movement and rate of water ingestion during rain harvesting in the Texas horned lizard, *Phrynosoma cornutum*. *Amphibia-Reptilia*, 25(1), 29-39.
- WC, S. (1990). Rain-harvesting in the lizard, *Phrynosoma cornutum*: behavior and integumental morphology. In *J.Herpetol.* 24 (pp. 302-308).
- WC, S. (1993). Rain-drinking behaviors of the Australian Thorny Devil(Sauria: Agamidae). In *Herpetol.* 27 (pp. 270-275).
- WC, S. (2004). Integumental water movement and rate of water ingestion during rain harvesting in the Texas horned lizard, *Phrynosoma cornutum*. In *Amphib-Reptil.* 25 (pp. 29-39).
- WHITFORD WG, B. M. (1979). Behavior of a predator and its prey : the horned lizard (*Phrynosoma cornutum*) and harvester ants (*Pogonomymex* spp.). In *Ecology* 60 (pp. 686–694).
- WOOD, D., VAILATI, C., MENGES, A. AND RÜGGEBERG, M., 2018. Hygroscopically actuated wood elements for weather responsive and self-forming building parts – facilitating upscaling and complex shape changes. *Construction and Building Materials*, 165, 782–791.

D1.P2.S3

COMPUTATIONAL ENCULTURATION I

SOCIAL NETWORK ANALYSIS OF DIGITAL DESIGN ACTORS

Exploratory Study Covering the Journal Architectural Design

SÜMEYYE TAŞDELEN, LEMAN FIGEN GÜL

Istanbul University, Istanbul, Turkey

Email address: hsumeyyetasdelen@gmail.com

Istanbul Technical University, Istanbul, Turkey

Email address: fgul@itu.edu.tr

Abstract. This research asks the question of how the design knowledge production mechanism is processed differentiates digital design actors from each other in the social media/professional and academic fields of architecture. Due to the broad nature of the research question, the study focuses on academia and academia-related media through prominent architect-authors and subject titles in the literature. Bourdieu's concept of capital is introduced, in which cultural and symbolic capital are considered part of the production values of digital design actors. Digital design actors use image-based social media tools such as Instagram effectively. The paper uses two methods: the first is a bibliographical analysis of author-texts, and the second is a social network analysis. By employing the keyword-based search from the Web of Science database, this study has managed to extract papers with full records (citations, keywords, and abstracts), with the journal *Architectural Design* having most publications. Considering that both academicians and professionals contribute to publications in *Architectural Design*, we selected all its publications between 2010-2020 for bibliometric analysis. These analysis techniques include the bibliometric network analyses and social network analysis with the focus on visualizing the algorithms and statistical calculations of well-established metrics. The research reveals the most critical nodes of the bibliometric network by calculating the appropriate central metrics. The network formed by the selected Instagram accounts of digital design actors are shown to be a small-scale network group, while the hashtags of digital design concepts are more numerous than the digital design actors.

Keywords: *digital design elites, symbolic capital, eminency of the digital design field, disciplinary knowledge, data visualization, social network analysis, digital architectural humanities.*

SOCIAL NETWORK ANALYSIS OF DIGITAL DESIGN ACTORS

ملخص . يطرح هذا البحث سؤالاً حول كيفية معالجة آلية إنتاج المعرفة التصميمية التي تميز الجهات الفاعلة في التصميم الرقمي عن بعضها البعض في المجالات المهنية والأكاديمية للهندسة المعمارية. نظرًا للطبيعة الواسعة لمسألة البحث ، تركز الدراسة على الأوساط الأكاديمية والوسائط الأكاديمية ذات الصلة من خلال المؤلفين المعماريين البارزين وعناوين الموضوعات في الأدب. تم تقديم مفهوم بورديو لرأس المال ، حيث يعتبر رأس المال الثقافي والرمزي جزءًا من قيم الإنتاج لممثلي التصميم الرقمي. يستخدم ممثلو التصميم الرقمي أدوات الوسائط الاجتماعية القائمة على الصور مثل Instagram بشكل فعال. تستخدم الورقة طريقتين: الأولى هي التحليل البليوغرافي لنصوص المؤلفين ، والثانية هي تحليل الشبكة الاجتماعية. من خلال استخدام البحث المستند إلى الكلمات الرئيسية من قاعدة بيانات Web of Science ، تمكنت هذه الدراسة من استخراج الأوراق بسجلات كاملة (الاستشهادات والكلمات الرئيسية والملخصات) ، حيث تحتوي مجلة Architectural Design على معظم المنشورات. نظرًا لأن الأكاديميين والمهنيين يساهمون في المنشورات في التصميم المعماري ، فقد اخترنا جميع منشوراتها بين 2010-2020 للتحليل البليومتري. تتضمن تقنيات التحليل هذه تحليلات الشبكة البليومتريّة وتحليل الشبكة الاجتماعية مع التركيز على تصور الخوارزميات والحسابات الإحصائية للمقاييس الراسخة.

الكلمات المفتاحية: نخب التصميم الرقمي، رأس المال الرمزي، شهرة مجال التصميم الرقمي، المعرفة التخصصية، تصور البيانات، تحليل الشبكات الاجتماعية، العلوم الإنسانية المعمارية الرقمية.

Introduction

In recent years, the field of digital design and computational technologies in architecture has been studied well; how the theoretical and practical correspond with one another is discussed among designs' fundamental issues. Digital design technologies have been embedded with scientific research methods and design methods that discuss the validity of conventional design practices. At the same time, by organizing inter-designer relations, designers have created a discussion platform where they can talk about the distinctive features of new designer profiles and design societies. Oxman (2005) examined the historical background required for the conceptual framework and theoretical foundations of digital design and asked whether the new thought processes of digital design apply to the majority of the design community or to a group the author early in the article labeled as the digital design elite. In the same article, the author mentioned the "digetari" class, referring to the designer's need for specialized knowledge as a digital tool manufacturer and stating the idea of digital intellectuals (literati) as advanced digital system creators to have defined contemporary situations (Oxman, 2005). At this point, digital intellectuals can clearly not be discussed as a general class. Factors should occur that distinguish digital designers (i.e., digital design elites) from technology evangelists.¹ Stevens (1998), in his book *The Favored Circle*, attempted to understand and define the ecology of the architectural field, specifically about those considered as outstanding architects. Using a concept set based on Bourdieu, he addressed the issue of

¹ A technology evangelist is a person who creates a critical mass of support for a given technology and then establishes it in a market subject to network effects as a technological standard (Url-1).

socialization in architectural education and social explanation for architectural creativity. He defended that there are greater social forces working to create architectural genius in his book. The scope of the current study will consider the factors that distinguish today’s digital designers and their acquisition of cultural capital with regard to digital design technologies and applications. The study aims to reveal the prominent groups and actors in digital design ecology using a network analysis formed over the design styles (concepts) related to digital design actors’ practices.

1. Bourdieu’s Concepts: Analysis of the Artistic-Scientific Field

Habitus is a concept that expresses “the way in which individuals ‘become themselves’—develop attitudes and dispositions—and, on the other hand, the ways in which those individuals engage in practices.” (Webb, 2002, p. 12). Also, habitus is internalized cultural capital Bourdieu's definition (Webb, 2002, p. 12). Meanwhile, symbolic capital is the form this habitus contains that “every type of capital (economic, social, cultural) takes from the moment it is perceived (in a sense) scientific capital is itself a kind of symbolic capital; that is, it is based on proficiency; it cannot be determined outside of relationality” (Bourdieu, 2015, p. 47). In summary, a very brief example on Bourdieu’s field theory can be given from a study describing an artistic field (Maanen, 2009). The artistic field is a structure of relations among positions struggling for a particular symbolic capital (prestige) based on a common illusion and their doxa, as well as with the help of various forms of capital (Fig. 1).

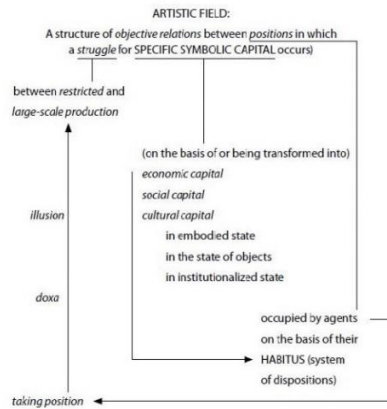

Figure 1. Key concepts in Bourdieu’s field theory (Maanen, 2009).

Stevens (1998, p. 168) stated architecture in almost all of history to have relied on the transfer of symbolic capital through chains of masters (teachers) and students, personal contact networks of self-reproduction. He stated the way architecture reproduces itself to be through formal education placed adequately in universities. On the other hand, emphasizing the importance of

SOCIAL NETWORK ANALYSIS OF DIGITAL DESIGN ACTORS

social capital in architecture always includes biographical studies. For instance, although Frank L. Wright did not have any architectural education (he studied engineering), he was able to become an important figure in modernist architecture due to the business-education opportunities he provided through his familial and social relations (see Url-2). Concordantly, the quality of the capital in the field may vary. For instance, scientific capital, which is itself a symbolic capital, may not be enough to gain an authoritative position (Bourdieu, 2013, p. 45). Bourdieu stated the symbolic world to mostly define the authority mechanism through culture (Stevens, 1998). Looking at examples is necessary in which cultural analyses have been made with quantitative tools. The Paul Jones' (2011) essential assumption in his book *Sociology of Architecture* is that the value unique to the field of architecture is aesthetics (Larson, 2015). However, the current parameters of the aesthetic issue are sensitive to debate. Additionally, scales on creativity continue to be an intellectual assessment factor in the field of design. In the article discussing creativity in the post-anthropocentric age, Roudavski (2016) calls upon people to think about which factors and who should be considered creative when the human-computer relationship reaches a symbiotic level. In this sense, he stated that computers (computational interfaces) may not be tools or collaborators, but rather factors that create templates for designers' attitudes and behaviors. Creativity is a factor that differentiates cultural taste in a particular area. In the same vein, Manovich (2009) investigated the meaning of representing culture through data. In a cultural analytics lab, Lev Manovich demonstrated concepts and methods for computational analysis of cultural data, focusing on visual media such as Instagram, Pinterest, and Flickr. He truly offered the nontechnical introduction to key concepts of data science and discussed the ways that society uses data and algorithms. Vrana et. al (2019) investigated museums by measuring the required centrality metrics and network analysis of museums' Instagram accounts. The study demonstrated the most relevant nodes of the network and showed the network created by the museum's Instagram accounts to be a scale-less small world network. One of the results from that study was that museums prefer to associate with other museums with whom they share common characteristics and build significant connections with museums that are similar to them. For instance, the British museum (an art museum) and the Louvre are the most prominent museums. Authors (2019) said that when Instagram accounts gather around other museums and collaborate with the authority museums, they begin to resemble the authority museums and become more akin to community centers; their exposure on Instagram improves and they draw more attention and a wider audience to their account.

2. Methodology

Our research framework comprised of two analysis methods to discuss the results within the scope of Bourdieu's capital and field theory. Bourdieu defined social capital as the "aggregation of the actual or potential resources" that are linked to the institutionalized membership of a group, determined by a sustainable social network of mutual knowledge and recognition (Farr, 2004; as mentioned in Zhao 2020). Another capital type is cultural capital that can be existed in three form for Bourdieu: embodied state (personal knowledge, cultivation), objectified state (such as books, instruments, machines) and institutionalized state (educational qualifications) (Zhao, 2020). The symbolic meaning of culture is provocative to discuss in the field of digital design. In relation to one question is how social media explain that symbolic meaning embedded in the digital design culture. Hence, capital theories can be employed to field of design knowledge production.

2.1. BIBLIOMETRIC NETWORK ANALYSIS

Bibliometrics is a common technique used for quantitatively analyzing literature. It is one of the few quantitative methods that can provide an analytical view by analyzing citations, co-citations, or an incorporation of both (Kah-Hin Chai & Xin Xiao, 2011). Visualizing bibliometric networks is usually done using citations, co-citations, bibliographic matching, keyword co-creation, and co-authored networks. These are carried out through three basic visualization approaches: distance-based, graph-based, and timeline-based. A bibliometric network consists of nodes and edges (Van Eck & Waltman, 2014). For instance, nodes can be publications, journals, researchers, or keywords. Edges show the relationships between node sets. In this context, keywords related to the subject of interest can be investigated in scientific databases (e.g., Web of Science, Scopus), and publications in the selected date range can be downloaded and used in different formats (e.g., Ris, Endnote, RefWorks). In this sense, we searched the keywords of "architects" AND "computational design" OR "digital design actors" on the Web of Science. By doing this, we conduct the citation analysis of journal names for the 78 selected papers (all papers found by keywords) taken from the Web of Science. The distribution frequencies of the papers selected from among the different journals reveal the journal *Architectural Design*²(AD) to have included the subjects we were searching and interested in. After this research on the Web of Science, we selected the journal AD for a text analysis due to it having played an essential role in the digital revolution in architecture since the 90s. Also, AD provides a crucial visual resource on the work done around

² <https://onlinelibrary.wiley.com/journal/15542769>.

SOCIAL NETWORK ANALYSIS OF DIGITAL DESIGN ACTORS

the world by discussing the latest trends and current issues from an international perspective. As Özkan (2014) stated in the interview with Helen Castle, one of the journal's editors, having a publishing approach that brings professionals and academics together ensures that the journal has a strong cultural impact in the field of architecture (Url-2). Therefore, in order to discover the digital design actors, we then used a journal-based search on the Web of Science to analyze the findings regarding *AD*'s publications between 2010-2020, which on the avant-garde topics and projects of the design field; conceptual mapping was done by analyzing the bibliographic text. As a result, we analyzed all the papers and articles from 2010 to 2020 using VosViewer and then compared the results (See Figs.4, 5, 6). The results show the co-authorship analysis and co-occurrence of keywords among the papers. The circular nodes with different colors in Fig. 5 represent different clusters. The node sizes indicate the number of papers associated with authors' names, and the arcs show co-authorship connections between authors. The gaps between the nodes are inversely related to the closeness of collaborations and citations (Fig. 4).

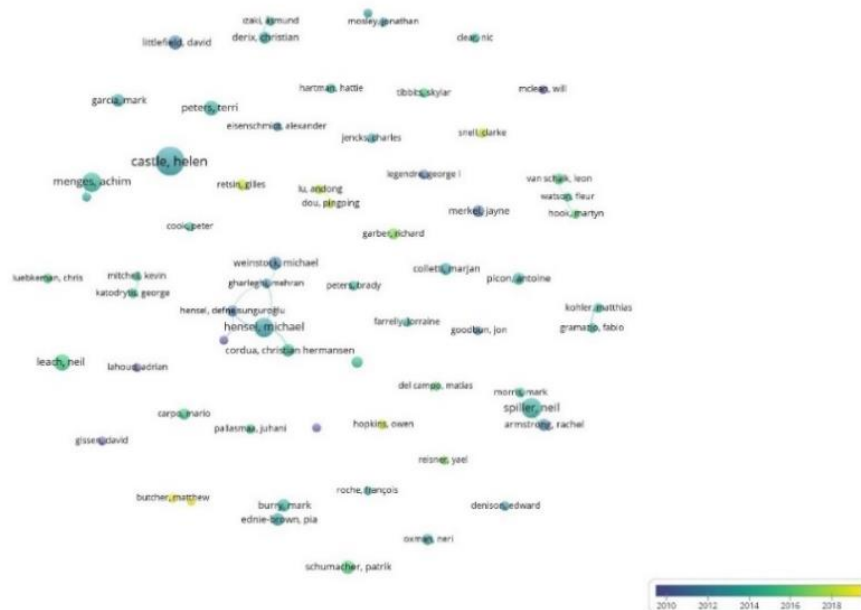

Figure 4. Co-authorship analysis of *AD*'s papers between 2010-2019 (five or more times).

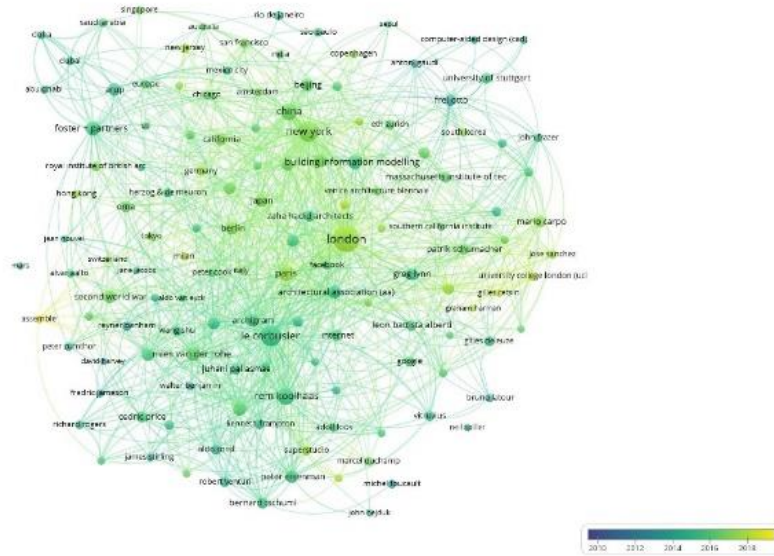

Figure 5. Co-occurrence of keyword analysis of AD (for each word occurring at least 10 times).



Figure 6. Search results of AD's publications on Web of Science with regard to the names of authors and organizations among its 1,282 papers between 2010-2020.

SOCIAL NETWORK ANALYSIS OF DIGITAL DESIGN ACTORS

The most cited papers among the 1282 papers from *AD* were selected. It could be seen that the most cited topics consisted of digital materiality, material computation, digital and design fabrication and parametric geometry in general. Skylar Tibbits, Achim Menges, Neri Oxman, Neil Spiller, Mark Burry, Fabian Scheurer, David Rutten and Neil Leach are seen to have been productive in terms of publication and citation rates. Particularly, the popularity of the subjects “digital materiality” and “robotic/digital fabrication in architecture” can be identified in the first years of the 2010s. We also see some cities/states as nodes in the co-occurrence of the keyword analysis, such as Berlin, Sao Paulo, New Jersey, Beijing, Seoul, Paris, Copenhagen, Singapore, Hong Kong, California, London, Doha, and Dubai. England, USA, and Australia tended to be the top three with the most papers on the Web of Science in the *AD* analysis. University of London, University College London, Harvard University, and MIT (Massachusetts Institute of Technology) are the top four organizations supporting academicians in their publications. Therefore, these results primarily give first ideas about the places, organizations, digital design actors and their networks.

2.2 SOCIAL NETWORK ANALYSIS OF DIGITAL DESIGN ACTORS

Network theory, or the study of social networks (SNA), is a developed theory that can help in exploring the presence of interconnected units (Vrana et al., 2019). Social media networks, meme spreads, data distributions, friendship relations, business relations, social networks, and partnership graphics are commonly visualized through social network research. The strategies for network analysis express the conventional proclamations and proportions of social structural properties that may somehow or another be characterized distinctly in metaphorical terms (Wasserman & Faust, 1994). Phrases like social role, social position, webs of relationships, groups, and popularity are mathematically defined by social network analysis tools. Also, some key concepts are found to be fundamental in discussing social network such as actor, group, mode, subgroup, relation, and dyad/triad (Wasserman & Faust, 1994). One important concern for a social network analysis is which actors to include. This means who are the relevant actors. These actors may be a group of people, a subgroup, organizations, or just people. To define the relations among actors or groups, the mode of affiliation should be recognized. If the group of actors contain two different set of actors, the network called as two-mode of network. For instance, in our study we worked with two main different set of actors, digital design actors and organizational actors. So, one set of actors have ties with the other set of actors, however the relationship does not have to be directional. Gençer (2017) noted that relationships need to be correctly described. In this study, we consider the educational and professional relations of actors in our network analysis.

Visual-based social media have encountered amateur content producers and allowed them to spread and create their content, which has significantly affected the way we communicate visually. In this sense, looking at the number of images tagged with architects-writers' names on the Instagram, we reviewed as a result of the bibliographic analysis can give an idea about these authors' social media profiles. The main goal of data analysis in many social network applications is to classify the most significant actors in a network. If the actor is extensively involved in relationships with other nodes that form a social network, a network node (actor) is considered to be a prominent one. In addition, a node's importance depends on the number of prominent nodes linked to it. For non-directional relations, the central actor is defined as one involved with many ties (Wasserman & Faust, 1994). For instance, being a follower on social media (Instagram), being a colleague and also educational relations are accepted as indirect relations and one can have all these types of ties with others separately. Thereby, we have selected 29 actors and 7 institutions from the results of the bibliometric study and investigated their social media accounts and biographical texts. Significantly, the Instagram account of Zaha Hadid Architects seems has more follower than institutional accounts and other actors' accounts. Moreover, the number of follower and like number of posts does not have to correspond to engagement of users in social media platform. Engagement rate is a formula that measures the amount of social content interaction that is earned relative to reach or other audience figure. Total engagements typically represent a list of likes, favorites, reactions, comments, shares, views, retweets, and sometimes include clicks, depending on which platform you use. Social media marketing experts say agree that powerful Instagram engagement rate corresponds around %1 to %5 (Url-3).

$$\text{Engagement Rate (\%)} = \left(\frac{\text{Likes + Comments + Shares}}{\text{Total Followers}} \right) \times 100 \quad (1)$$

We see that some authors have no Instagram account or do not use social media tools. Seeing that visual-based social media is used to share works and develop networks is important. For instance, British theorist and architect Neil Leach is the architect with the highest number of citations among the authors scanned under *AD* with 3,855 citations and a 40 h-index rate (Url-4). This means that some digital design actors solely make productions in the academic field as theoreticians. They do not use social media as a network tool.

According to the results, organizational actors seem has more strong engagement and more follower in total. AA³ comes the first strong engagement among organizational actors. Then, Sci-Arc⁴ and MIT⁵

⁴ <https://www.sciarc.edu/>

⁵ <https://architecture.mit.edu/>

SOCIAL NETWORK ANALYSIS OF DIGITAL DESIGN ACTORS

Architecture rank. Secondly, when we look at the digital design actors we see Instagram accounts of Foster and Partners, Arturo Tedeschi and Zaha Hadid official as having a powerful engagement rate (Fig. 7). When these actors are looked closely, it is seen that they are active Instagram users and they are sharing strong content. For instance, Tedeschi shares more industrial design (furniture, installations, products, footwear) and automotive designs and he develops its forms with an algorithmic / parametric design approach and also novel digital fabrication technics. Zaha Hadid official already has a separate computational design research group ZHA code⁶ which is to make create with emergent fabrication technologies. Founder Zaha Hadid held numerous chairs and guest professorship at universities around the world including Harvard, Yale, Columbia (Url-5). ZHA's practices can be accepted as influential in the field of avant-garde digital architecture practices. Schumacher says that ZHA's view on architecture has always been digital, in that it relied on curved deformations, multiple focal points, and extreme angular views (Schumacher, 2004). Also, he mentioned that digitally trained AADRL students have a good contribution on the novel practices in ZHA. Social network analysis is done within the Gephi which is a program for network visualization and used Force Atlas2 layout algorithm to view the spatialization process and to turn the network into map (Fig. 8). The actors' biographies and their educational backgrounds effected the results of network map. Still, this map is not enough to differentiate symbolic capital of actors which is gained by academic prestige, architectural practice or new-media tools. However, we see the educational programs in UK dominate the digital design practices, particularly Bartlett School and AA. Even though, they have an effective use of social media considering their social media engagement rates, there have not been a very strong nodes among the actors reached as a result of the MIT Architecture, Sci-Arc bibliometric analysis. In that point, we can compare the differences of education-based digital design practices mainly in four different country; USA, UK, Spain and Switzerland.

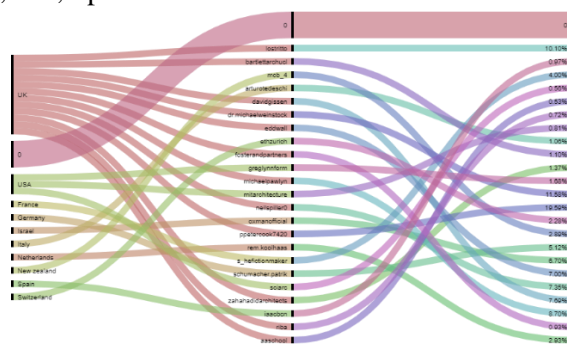

Figure 7. This alluvial diagram shows that engagement rates of digital design actors and organizations on Instagram and their nationality.

⁶ <http://www.zha-code-education.org/Contact>

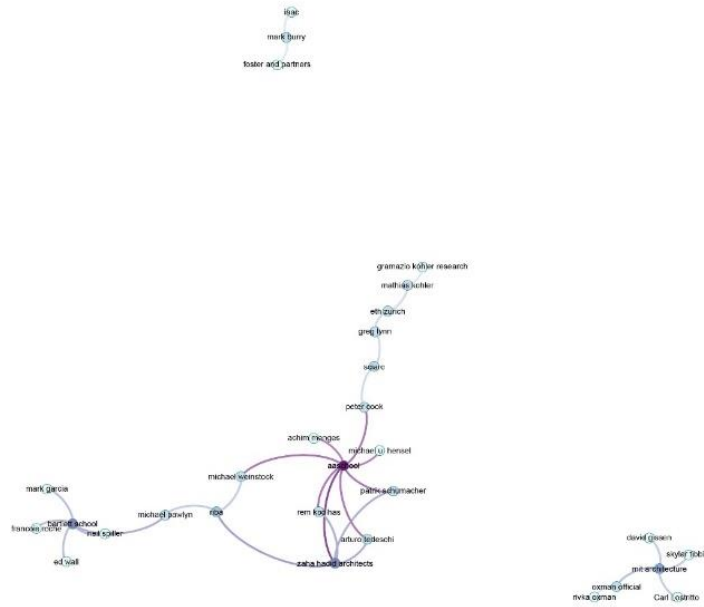

Figure 8. This graph shows that undirected relations of actors and degree metrics, prepared with Gephi (with Force Atlas 2 layout).

3. Findings and Discussion

Some topic titles, cities as project areas, and author names appear to stand out by taking into consideration the findings from the bibliometric study and social media study. In the field of digital and computational design, UK-based organizations and architects are more prominent, followed by similar US-based architects and organizations. Digital design actors who are active in social media/professional and academic fields are seen to likely be different actors. A research writer-architect with great influence in the academic field may not have the same influence and reputation in the professional field. Increasing complexity of roles and types in the architectural field, including the emergence of theorist-practitioners, affects capital types and field prominence. For the most part, media, digital design and capital are connected with each other. Social media may contribute to create and help the new “digetari” class for gaining symbolic capital. It is also inclined to be prestigious for professional competition which “is best seen in the maintenance and expansion of disciplinary knowledge” (Kong, 2014, p.39). Golden (2017) discusses the contemporary knowledge and arguments about architects’ shifting roles and types of practice in privatized. Actually, he investigates the key stages of architectural practice in UK from the 1950 to 2015. He argues the shifts within profession with the help of diagrams that

SOCIAL NETWORK ANALYSIS OF DIGITAL DESIGN ACTORS

show the different types of architect agents such as activist, artists, corporate agents in the field of traditional norms and established capitals which are related with Bourdieu's concepts. The roles and types of agents can proceed to be explored in the novel design knowledge production mechanism and in its variations. Oxman (2017) says that sketching by code is promises to become a new norm of skill and knowledge. Also, traditional role of visual image in paper-based design is changed with parametric design. So, it is open to discuss that new symbolic meaning of scripting (visual code) and its integration with visual form in the practice of design culture. Meanwhile, Schumacher said, "Contemporary arguments for greater architectural autonomy tend to focus on the status quo of architects as design experts with traditional building design/ management skills enhanced by new technology (as cited in Golden 2017). So various views exist that compete over mainstream architectural production. Also, Awan et al. (2011) mentioned, "There is no clear consensus about either the future center of architectural culture or how to interrogate the status quo and change it for the better." The limitations of the study are bounded by the set of actors and organization taken into account, as the paper only investigates the list of prominent actors. Further research needs to take into consideration all the digital design actors that have an Instagram account by interpreting their works and digital design concepts together.

References:

- Awan, N., Schneider, T., Till, J., 2011. Spatial agency: other ways of doing architecture. Routledge.
- Bourdieu, P. (2015), Bilimin Toplumsal Kullanımları Bilimsel Alanın Klinik Bir Sosyolojisi İçin, Heretik Yayınları:4 Pierre Bourdieu Dizisi: 2, Ankara, 2.baskı.
- Bourdieu, P., 1986. The forms of capital. In: Richardson, J.G. (Ed.), Handbook of Theory and Research for the Sociology of Education. Greenwood Press, New York, NY, pp. 241e258.
- Bourdieu, P., 1973. Cultural reproduction and social reproduction. In: Brown, Richard (Ed.), Knowledge, Education and Cultural Change. Tavistock, London, UK, pp. 71e112.
- Gençer, M. (2017). Sosyal Ağ Analizi Yöntemlerine Bir Bakış. Yıldız Social Science Review, 3 (2), 19-34. Retrieved from <http://dergipark.org.tr/en/pub/yssr/issue/33542/334638>.
- Golden, Saul. (2017). Mapping the expanding and fracturing field of architecture. 10.1201/9781315226255-108.
- Kong, K. (2014). Professional Discourse, Cambridge University Press, pp 39.
- Maanen, van H., (2009), Pierre Bourdieu's Grand Theory of the Artistic Field, Book Title: How to Study Art Worlds, Book Subtitle: On the Societal Functioning of Aesthetic Values, Published by: Amsterdam University Press.
- Manovich, L. (2016) The Science of Culture? Social Computing, Digital Humanities and Cultural Analytics, Journal of Cultural Analytics.
- Oxman, Rivka. (2006). Theory and design in the first digital age.
- Oxman, Rivka. (2017). Thinking difference: Theories and models of parametric design thinking, 0142-694X Design Studies 52, 4-39.
- Wikipedia contributors. (2020, February 24). Technology evangelist. In Wikipedia, The Free Encyclopedia. Retrieved 13:14, April 15, 2020,

- from https://en.wikipedia.org/w/index.php?title=Technology_evangelist&oldid=942326304.
- Stanislav Roudavski (2016) Field creativity and post-anthropocentrism, *Digital Creativity*, 27:1, 7-23, DOI: 10.1080/14626268.2016.1151443.
- Stevens, G. (1998). *The favored circle*. Cambridge: MIT Press.
- Waltman, L., van Eck, N. J., & Noyons, E. C. M. (2010). A unified approach to mapping and clustering of bibliometric networks. *Journal of Informetrics*, 4(4), 629–635. doi:10.1016/j.joi.2010.07.002.
- Schumacher, P., (2004), *Digital Hadid. Landscape in Motion*, Birkhäuser, Basel, pp. 96.
- Schumacher, P., 2010. *The Autopoiesis of Architecture: A New Framework for Architecture*. John Wiley & Sons.
- Van Eck, N. J., Waltman, L., Dekker, R., & van den Berg, J. (2010). A comparison of two techniques for bibliometric mapping: Multidimensional scaling and VOS. *Journal of the American Society for Information Science and Technology*, 61(12), 2405–2416. doi:10.1002/asi.21421.
- Van Eck, N.J., & Waltman, L. (2014). Visualizing bibliometric networks. In Y. Ding, R. Rousseau, & D. Wolfram (Eds.), *Measuring scholarly impact: Methods and practice* (pp. 285–320). Springer.
- Vrana, Vasiliki & Kydros, Dimitrios & Kehris, Evangelos & Theocharidis, Anastasios-Ioannis & Karavasilis, George. (2019). A Network Analysis of Museums on Instagram. 10.1007/978-3-030-12453-3_1. Jones, Paul. 2011 *The Sociology of Architecture: Constructing Identities*, Liverpool, Liverpool University Press
- Zhao, X. (2020), Game of capitals: Production of influential online architecture, *Frontiers of Architectural Research*, Volume 9, Issue 3, page: 670-680.
- URL 1, retrieved from 05.10.2020< https://en.wikipedia.org/wiki/Technology_evangelist>
- URL 2, retrieved from 25.06.2020< <https://www.youtube.com/watch?v=rpO4FplWdtI>>.
- URL 3, retrieved from 01.02.2021< [https://scholar.google.com/citations?user=FyXDqdoAAAAJ&hl=en](https://blog.hootsuite.com/instagram-engagement/#:~:text=Instagram%20itself%20is%20coy%20about,rate%20of%204.59%25%20in%202020.>.</p><p>URL 4, retrieved from 25.06.2020:
<a href=).
- URL 5, retrieved from 02.02.2021< <https://www.zaha-hadid.com/people/zaha-hadid/>>

WE GAIN A LOT...BUT WHAT ARE WE LOSING?

A Critical Exploration of the Implications of Digital Design Technologies on Sustainable Architecture

ARISTOFANIS SOULIKIAS, CARMELA CUCUZZELLA,
FIRDOUS NIZAR, MORTEZA HAZBEI

Concordia University

Email address: aristofanis@gmail.com

Email address: Carmela.Cucuzzella@concordia.ca

Email address: fn24x7@gmail.com

Email address: m.hazbei@gmail.com

AND

SHERIF GOUBRAN

The American University in Cairo

Email address: sherifg@aucegypt.edu

Abstract. In the field of architecture, new technologies are enabling us to promptly simulate, quantify, and compare multitudes of design alternatives and consider an ever more expanding list of environmental and economic parameters within the early design phases of projects. However, architecture today veers further towards non-neutral technologies, changing our culture, introducing new values, and (re)shaping our social ideals. The change of media, from the manual to the digital, has deeply transformed architecture and city design. There is undoubtedly progress, but what are we losing in this automation, virtualization and over-digitalization? Are architects—creators of space, human experience, and cultural capital—starting to occupy the role of technicians? Sustainable architecture is a field that is already experiencing tensions between the quantitative and the qualitative, the optimum and the ethical, and the parametric and haptic methods. Yet the rapidly evolving CAAD technologies overlook many of the non-quantifiable values of these binaries. Gains in speed and efficiency in the design process with the help of parametric design may be challenging the designer's *reflection-in-action* process required for critical architecture while ethical, cultural, and human dimensions can hardly be modelled algorithmically. Similarly, computational thinking and digitalization in architectural education, have yet to come to terms

with the loss of analogue ways of learning that favour a more diverse and inclusive classroom environment. Instead of keeping the analogue and the haptic practices away from the immaculate realm of CAAD, this paper argues for hybrid technologies that recognize these practices and their value in sustainable design and incorporate them. Film animation, as a branch of architecture's most expressive means, film, can serve as a paradigm of a feasible disruptive technology, but most importantly, as an indicator of the hybridity between the handmade and the digital and its effectiveness in expressing vital elements of sustainability that are otherwise dismissed.

Keywords: *Digital tools, handmade images, parametric design, environmental sustainability, architectural pedagogy, reflection in action, hybrid visualization techniques.*

ملخص. في مجال العمارة , قد تمكنا من خلال التكنولوجيا الرقمية الجديد من ان نحكي ونحسب الكميات ونقارن العديد من البدائل وكذلك اتخاذ القرار الفوري مع الأخذ في الاعتبار العديد من المحددات البيئية والإقتصادية وذلك من بدء المراحل الأولى للمشروع .ومن هنا نجد أن العمارة في الوقت الحالي تميل إلى التكنولوجيا غير المحيدة التي تغير من الموروثات وتقدم قيما جديدة وتساعد على تشكيل القيم الإجتماعية .فالتغيير في الميديا من التقليدية إلى الرقمية قد أثرت بشدة في تطوير العمارة والتصميم العمراني للمدن. من المؤكد أنه هناك تقدم هائل. ولكن ماذا نخسر من هذا التطور إلى الميكنة أو الأوتوماتش والإفتراضية والتوغل في الرقمية؟.. هل الإبداع المعماري والخبرات الحياتية والجذور الثقافية قد بدأت في أن تستبدل بالطرق التقنية؟ إن مجال العمارة بالفعل يتعرض إلى شد وجذب بين نظريات الكم والكيف وبين المثالية والأخلاقيات وبين المحدود والملموس. وما زال التسارع لتكنولوجيا CAAD تصطدم بالعديد من المحددات غير القابلة للقياس .إن المكتسبات الحادثة في الكفاءة والسرعة في عملية التصميم بمساعدة محددات التقييم قد تكون محفزة للمعماري لأن ينعكس ذلك علي التطور المطلوب في التصميم من أجل عماره متميزة بينما المثل والحضاره والأبعاد الإنسانية قد يكون من أصعب ما يكون وضعها في معادلات قياسية .وبالمثل التحول الى التصميم الرقمي عن طريق الحاسبات يأتي في الدراسة المعمارية علي حساب الطرق التناظرية للتعليم والتي تتطلب معرفة شاملة ومتنوعة من خلال الفصول الدراسية. فبدلا من أن تبقى الطرق التناظرية و الممارسات المحسوسة بعيدا عن عالم CAAD النقي نجد أن هذه الورقة البحثية تناقش إستحداث تكنولوجيا تجمع بين هذه التطبيقات التكنولوجية والطرق التقليدية وقيمتها في التصميم المستدام وتدمجهم معا .وأیضا يمكن تناول "الأنيماشن" أو العروض التخيلية كفرع من أقوى الوسائل للتعبير عن التصميم المعماري والتي يمكن أن تخدم كنموذج للتكنولوجيا التي يمكن أن يكون لها تأثير هادم ولكنها أهم شئى تعمل كمؤشر للدمج بين التصميم التقليدي والرقمي ومدى كفاءتهما في التعبير عن العناصر الحيوية للإستدامه والتي كان ممكن أن تتعرض فيما عدا ذلك للإستبعاد .

الكلمات المفتاحية: الأدوات الرقمية، الصور المصنعة يدويا، التصميم البارامتري، الاستدامة البيئية، التعليم المعماري، الانعكاس التصميمي، أدوات الإظهار المختلطة.

1. Introduction

1.1. DIGITALIZATION IN ARCHITECTURE

The digital age has brought tremendous changes to our world. In architecture, digital tools have revolutionized the way drawings are produced, as well as how buildings are visualized, optimized, assessed, and constructed. However, the recent developments in computing abilities are confronting design and architecture with new technologies that are increasingly substantive. Today, architectural design is increasingly relying on digital technologies, changing our culture, introducing new values, and (re)shaping our social ideals. The change of media, from the manual to the digital, has deeply transformed architecture and city design.

In this environment of technological dominance, the architect is asked to take up new responsibilities. Sustainability is a case in point.

2.1. A CONTEMPORARY VIEW OF SUSTAINABILITY

Over the last decades, we transitioned our collective understanding of sustainability from a product-focused one (i.e. green design) to one of system innovations (i.e. design for sustainable transitions) (Ceschin & Gaziulusoy, 2016). While many of us still associate, ground and define sustainability in architecture through eco-efficiency (i.e. the optimization of environmental performance metrics), this measurement-driven definition contradicts the multitude of meanings, and non-technical layers that can contribute to the sustainability of a *place* (Cucuzzella & Goubran, 2020). It also disregards the formal definition of sustainability as an intersection of domains; the social, economic and environmental, in its most basic sense, with the addition of the cultural (McMinn & Polo, 2005), ethical (Ehrenfeld, 2009), or spiritual (Walker, 2006, 2015) in its more elaborate forms.

In a series of articles published in the early 2000s, Guy and Farmer (Farmer & Guy, 2004, 2005; Guy & Farmer, 2000, 2001) have established a seminal vision to comprehending and applying the concept of sustainability meaningfully – in what they defined as "pluralistically". This is well-aligned with the view that a stable, or bounded definition of sustainability in architecture, will reduce the process of design (i.e. sustainable design) to a series of managerial decisions around energy, water and feasibility (Cucuzzella & Goubran, 2020; Pyla, 2008; Vandevyvere & Heynen, 2014).

In the ever-changing realities, we are certain that the architect's role has to transition from that of the technical advisor to one of "a more sociological engineer or entrepreneur" (Mooi, 2014). While technologies, and information and communication technologies (ICTs) in specific, have become defining

features to our sustainability approach, it is essential not to confuse the designer's role with that of the technology integrator. In that sense, we have to consider that sustainability can only be attained by balancing between the high- and low-tech (Beder, 1994), between the smart and the human, between the digital/artificial and the natural, and the imagined and the real.

2. Critical Perspectives

2.1. BUILDING DESIGN AND PROCESS

New digital tools have influenced the whole field of architectural design over the past decades, leading to *parametricism* (Schumacher & Leach, 2009). This practice, which is the direct result of digital tools in architecture, not only affects the design process but also has significant impacts on the architectural forms. To assess the effects of digitalization in their entirety, we will examine the role of parametric tools in the following two aspects: 1) the design process, and 2) the final results on the architectural process, namely, the architectural forms (Fig. 1).

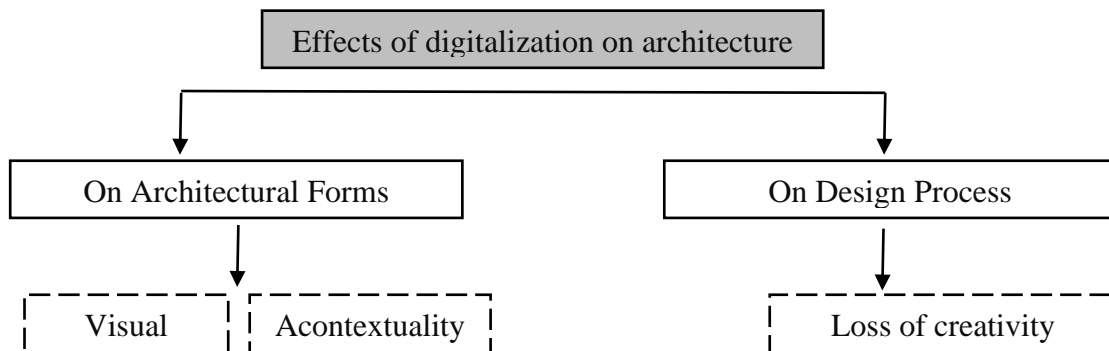

Figure 1. Assessing the effects of digitalization on both architectural forms and design process.

2.1.1. Digitalization and its effects on architectural design processes.

Unlike past design processes, which were based on improving the quality of design step by step, today, architects quantify parameters to generate and control different architectural variations while designers can explore multiple viable solutions and concepts without being limited by their own drawing and modelling skills (Lawson, 2002). They also can change and modify their own rule-based representations in any stage of the design process (Schumacher, 2008). This availability and means that are offered by digital tools lead to

WE GAIN A LOT...BUT WHAT ARE WE LOSING?

innumerable design alternatives that can be generated in parallel, which in turn allow for new modes of thinking and contribute to the explorative process (Barrios Hernandez, 2006; Holland, 2012; Karle & Kelly, 2011).

Such changes in the design process and methods have extended the boundaries of design knowledge (Gero, 1996; Liu & Lim, 2006). With them, however, come some shortcomings with regard to creativity. Traditionally, designers spent a lot of time on the design process, whereas today only one mouse click can provide thousands of alternatives. Although sketches (conventional design practices) are a time-consuming process, have few details, tend to suggest and explore rather than confirm by retaining a level of ambiguity (Poole & Shvartzberg, 2015), they allow the designer to spend more time on the artefact and engage in an exploratory search, discovering alternatives that were not conceived at all in the preliminary design phase. Schon (1987) names these emerging ideas a *reflection in action*. In other words, whereas in parametric design, all design alternatives are restricted to the initially defined code and parameters and cannot go beyond them, in traditional methods of design, the ambiguity of sketches has the potential to trigger new ideas outside a defined “box”.

One might say that in the parametric way of design, designers can change and modify their own rule-based models at any stage of the design process so that it can be kept open and flexible (Oxman & Gu, 2015). Yet in reality, their possible changes are limited to the rules that they themselves have set for the design problem in the first place. Recoding the whole process, would be more time-consuming than any traditional design method with the additional risk of missing all the alternatives that were generated initially as they would not be compatible with any new design code. This complexity of modifying or upgrading the code forces designers to narrow their alternatives within the current platform, since they are reluctant to recode the whole procedure (R. Woodbury, 2010). Consequently, a code-based design process would hinder creativity, since it would restrict designers to only one possible range of solutions.

2.1.2. Digitalization and its effects on architectural forms

In parametricism, architects rely solely on digital tools to design building forms through computer-aided design avoiding thus the nuanced reflection in action the hand enables. Although this transition from hand-drawn architecture to computerized architecture has brought possibilities to the table never imagined before, the drawbacks with regard to the architectural form can be easily recognized in some contemporary buildings of the last decade or so. In terms of formal features, incoherency can be considered an obvious predominant characteristic, both in the matching of the exterior to interior designs and their descriptive qualities. (Hazbei & Cucuzzella, 2021). Digital

tools increase computational control over design geometry (Dino, 2012) and are mostly used to create seductive and spectacular forms or even create an environmental envelope around the building overlooking basic architectural formal qualities such as the connection between site and building. In describing this technological advancement in architectural forms, Dalibor Vesely states that “complexity can be produced, but richness must be created” (Burry, 2013).

Digitalization facilitates form-finding processes and responds to site and climate requirements. However, these practices are increasingly depriving contemporary architecture of meaning (Grobman & Neuman, 2013). Parametric architecture, as it is practiced today, cannot convey contextual significance, since it considers merely climatic, topographic, and energy as regional factors (Mahgoub, 2007). In other words, parametric design focuses on digital forms and energy simulation techniques of buildings without addressing the cultural significance of local places (Lorenzo-Eiroa & Sprecher, 2013). Although this development in architectural digital tools can be considered as a way forward in environmental sustainability, it is a counteractive approach to cultural and social sustainability, producing acontextual architecture.

2.2. EDUCATION

Traditionally, the pedagogy of architecture design studios relied on hands-on and experiential learning techniques to equip students with the ability to critically reflect, brainstorm, and interact with their peers and surroundings while designing for time-intensive school projects (Schön, 1987). These peer-to-peer interactions, facilitated by the physical environment of the design studio, were beneficial to the growth of architecture students as they learned to exchange, debate and reflect on key concepts, values, and design principles that informed their tacit knowledge (Polanyi, 2009) and governed their future styles and workflows as licensed and practicing architects (Schön, 1987).

The application of digital design tools in projects for architecture schools has witnessed both positive and negative impacts on the nature of knowledge exchange between research and practice. While the swift adoption of digital technologies in the design process was imperative to the survival of architecture as a profession, the educational system continued to be skeptical of these advancements as they relied on the tangibility of creative outcomes through analogue resources such as hand-drawn project submissions, physical studio interactions, hands-on workshops, and field studies. Hence, most educational institutions persist in this tension between the digital and analogue dimensions of architecture pedagogy, and this results in a curriculum

WE GAIN A LOT...BUT WHAT ARE WE LOSING?

that is ambiguous in its approach to sustainably train young professionals for the future.

This increasing polarity between the digital and analogue is also observed in the user interface of CAAD tools that are often neutral and rigid in the hopes of structuring and democratizing the design process. However, given that these tools are used by creative individuals with diverse social and cultural backgrounds, the neutrality of its elements flatten and undermine the complexity and inherent "messiness" of the design studio (Gross and Do, 1999). While students are encouraged to experiment and tinker with unfamiliar materials and concepts and come up with designs through trial and error, digital design technologies have added socio-cultural and psychological inhibitions to this process as they have promoted speed, efficiency and accuracy of seemingly "finished" solutions. Although CAAD tools have witnessed an exponential growth in the capacity of students and practitioners to produce and share larger quantities of work, they spur on a competitive environment that can result in an unhealthy bypassing of initial research, meditation, and reflection of design principles and values, resulting in an uneven distribution of the quality of the creative outcomes (Buchanan, 2012).

Furthermore, the participatory design paradigm of the architecture discipline in recent years has led to a shift in the power dynamics of a learning environment, where the instructors and students now need to share a level plane of discussion and symbiosis of knowledge and other resources. In the traditional format of a design studio critique, students typically present their work in front of a passive audience and receive critical feedback from instructors only at the end of their design processes (Graham, 2003). Today, the rise of "e-studios" has witnessed a shift in this communication as students can share their work outside the physical boundaries of the design studio right from the inception of the projects (Al-Qawasmi, 2005). Although digital studios prompt students to think "fluidly" and generate multiple design outputs over a very short span of time, instructors now struggle to devote their time and attention to giving quality feedback to individual work before final submissions. Additionally, students tend to overlook the socio-cultural contexts of their designs by adopting global principles that arise from the gentrification caused by digital applications. Therefore, the paradigm of digital media in the design learning process needs to move away from a narrow technical perspective that views them as "value-free neutral (tools) that produce objective realities" (Al-Qawasmi, 2005).

Although there has been a drastic increase in the efficiency of projects designed using digital and parametric design platforms, computational thinking renders a complex design problem into disconnected smaller parts and can discourage students from critically reflecting on the outcomes of these codified processes (Kavousi et al., 2019). Digital design and parametricism

can have dire implications for the creative skills of architecture students, as they are given the freedom to blame the “machines” for not producing the expected results, absolving them of responsibility as designers (Miessen, 2016)

Hence, the over-digitization of design techniques and processes bring the need for architectural pedagogy to shift toward an inclusive, socio-cultural and political restructuring of the discipline in order to embrace more hybrid mechanisms in conflictual environments of learning and practice. Rather than focusing on the extremities of the digital-analogue debate in architectural education, future curricula can encourage hybrid forms of teaching and learning architecture that embrace both analogue and digital tools in techniques for sustainable architecture.

2.3. VISUAL EXPRESSIONS

2.3.1. *Film as Architecture Communicator (beyond photorealism)*

If digital technologies and parametricism obscure the role of architects and the degree of their responsibility vis-a-vis the design process, one has to recognize what that role is, namely, the creative role, the one being most at risk of being compromised. In a series of perceptive works, architect and architectural theorist Juhani Pallasmaa examines the entire creative process of the architect through the interaction between body and mind, between hand and eye. Without denouncing the conveniences of CAAD, he underlines the importance of conceiving architecture and even fabricating objects by engaging all of the senses, away from the computer screen. He argues that any tactile experience using a computer mouse is still an operation that takes place in an immaterial world and that “computer imaging tends to flatten our magnificent, multi-sensory, simultaneous and synchronic capacities of imagination by turning the design process into a passive visual manipulation, a retinal survey.” (2009, pp.96-97)

Hence, bodily ways of making are still crucial in the creative stages of architectural practice. This argument extends, naturally, into the realm of *communicating* architecture, in the classroom, the design studio but also in society at large. Maybe it is no coincidence that Juhani Pallasmaa is also a keen expert in film, which, according to him, is the medium *par excellence* in communicating architecture (2001, p.13), echoing thus a position held by numerous film scholars, going back to cinema pioneer and theorist Sergei Eisenstein himself (Eisenstein, Bois, & Glenny, 1989).

With this understanding of film’s capacity in expressing architecture, it is no surprise that the discourse around new moving image technologies and their potential to now act disruptively to the norms of photorealism is a very familiar one to architecture and film scholars alike. As CAAD technologies

WE GAIN A LOT...BUT WHAT ARE WE LOSING?

are increasingly encroaching on the realm of animated representations of space, critiques on how CAAD has limited design creativity logically extend to the computer-generated moving image. Architect and essayist, Stan Allen, used low-tech animated films as a paradigm for an approach to CAAD that focuses on abstraction and significance rather than on precision (2009, pp.89-90). This viewpoint echoed a wave of writers on film and filmmakers who had already explored the materiality of the medium itself within its analogue past but also in ways of experiencing space in film that is not centred around vision (Marks, 2000; Bruno, 2014).

Ultimately, all of these arguments are directly linked to a more holistic understanding of architecture, one which corresponds better to the human lived experience. One can argue that the banishment of the body and the excessive reliance on photorealism, as encouraged in major CAAD software, is at the expense of meaningful architecture and, consequently, a sustainable one.

As a type of film that can largely involve the handmade, film animation is particularly well positioned to express architectural space in all its hapticity. Film animators study and manipulate each film frame individually. This arrest of time allows them for a greater involvement of their bodies onto each frame that can be a photograph of a hand drawing or of a hand-crafted set, as is the case with stop-motion techniques. Interestingly, digital technology, instead of replacing, has in fact encouraged such techniques (Parks, 2020), resulting to new, hybrid, more accessible ways of expressing architecture.

2.3.2. *Last Dance on the Main: A Case Study*

In his own work as film animator, Aristofanis Soulikias seeks to express the built environment beyond its Cartesian constraints of measurable space, in the realm of the lived and bodily experience, which is communicated through the handmade aspects of his filmmaking process, such as the non-digital nature of the materials he uses and the physical environment in which he captures the individual photographic stills. *Last Dance on the Main*, his 2014 animated documentary about the demolition of a row of historic buildings in Montreal's former Red-Light District and the successful resistance put up by local artists and activists to preserve their venue is a characteristic example. All the scenes and movements in the film were manually fabricated, captured by a digital camera, and assembled into a film with a special stop-motion software. The handmade component of the film was the cutting of paper silhouettes and other translucent surfaces as well as the use of ready-made objects and printed material, all placed on a light table as to be mostly backlit. The incremental changes in position were done by hand, often by trial and error and many repeated attempts. The digital component consisted of the capture of photographic stills with a mounted DSLR camera facing the horizontal light

table surface and connected to a computer to which the images were instantly sent (Fig.2).

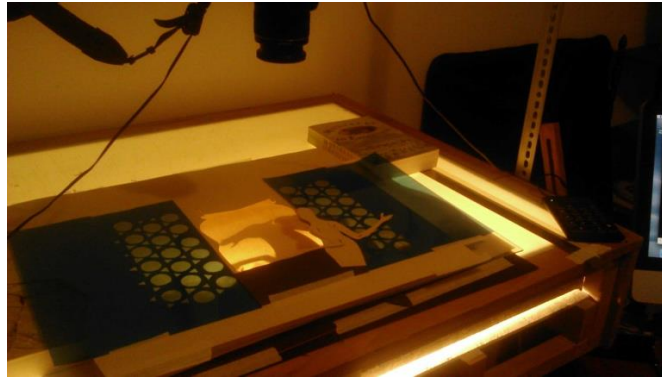

Figure 2. Production Still

Despite being a digital end-product, digital tools did not dictate the overall aesthetic or animation of the film but rather facilitated the registration, selection, and processing of the images, allowing for the artist to better concentrate on animating the paper silhouettes and the other objects he used for the film. Within this hybrid form of film animation, enough of the multilayered work made by hand became perceivable, as to become itself a metaphor for the layers of significance of the endangered buildings and the communities that supported them. Furthermore, a film that was made with relatively modest means and resources reached 65 festivals worldwide and won several awards, posing the question of what sustainability can mean for both architecture and the means of communicating it.

3. Conclusion

CAAD technology, as powerful as it has evolved, has had difficulty in encompassing a broader notion of sustainability as that is understood in the 21st century. The ultimate achievements of computational ways of thinking, speed, accuracy and efficiency, useful as they are, have yet to address successfully the idiosyncrasies of place and culture. Similarly, digital tools cannot necessarily replace the creative environments needed in architectural education or the architectural office. To address sustainability in architecture in its fullest sense, one needs to examine closely what is being lost and how that can be incorporated in today's architectural practices. This is not to imply that digital technologies cannot achieve some of the subversions and dissent from the tyranny of precision and speed (Hosea, 2019). However, hybrid ways of designing, making, and seeing, which involve both the digital and the

WE GAIN A LOT...BUT WHAT ARE WE LOSING?

analogue, the ideated image and the physical space, the mind and the body, point to that optimum where there is enough of that precious room for creativity, spontaneity, and, in general, a more accurate and direct response to the lived human reality, both on the ground where architecture materializes and in the minds of citizens where it is imagined. Sustainability is less about the limits of performance reached by computers and more about the fine equilibrium between powerful tools and that which directly addresses our sense of place and humanity.

References

- AL-QAWASMI, J., 2005. Digital media in architectural design education: reflections on the e-studio pedagogy. *Art, Design and Communication in Higher Education*. 4, 205-222.
- ALLEN, S., 2009. *Practice: architecture, technique + representation*. London: Routledge.
- BARRIOS HERNANDEZ, C. R., 2006. Thinking parametric design: introducing parametric Gaudi. *Design Studies*. 27, 309-324.
- BEDER, S., 1994. The role of technology in sustainable development. *IEEE Technology and society magazine*, Vol. 13 No. 4, pp. 14–19.
- BRUNO, G., 2014. *Surface*. London: University of Chicago Press.
- BUCHANAN, P., 2012. Whats wrong with architectural education? Almost everything. *The Architectural Review*. URL <https://www.architectural-review.com/today/1989-july-whats-wrong-with-architectural-education-almost-everything> (accessed 11.5.20).
- BURRY, M., 2013. *Scripting cultures: architectural design and programming*. Somerset: Wiley.
- CESCHIN, F. AND GAZIULUSOY, I., 2016. "Evolution of design for sustainability: From Product design to design for system innovations and transitions. *Design Studies*, Elsevier Ltd, Vol. 47, pp. 118–163.
- CUCUZZELLA, C. AND GOUBRAN, S., 2020. Caught between measurement and meaning. In Cucuzzella, C. and Goubran, S. Eds. *Sustainable architecture – between measurement and meaning*. Wilmington, Delaware: Vernon Press, pp. 1–13.
- DINO, I., 2012. Creative design exploration by parametric generative systems in architecture. *METU Journal of Faculty of Architecture*, 29(1), 207–224.
- EHRENFELD, J., 2009. *Sustainability by design: a subversive strategy for transforming our consumer culture*. New Haven, Conn.: London: Yale University Press.
- EISENSTEIN, S. M., BOIS, Y.-A., AND GLENNY, M., 1989. Montage and architecture. *Assemblage* (10), 111-131.
- FARMER, G. AND GUY, S., 2004. Hybrid environments: the spaces of sustainable design. In Guy, S. and Moore, S.A. (Eds.), *Sustainable architectures: critical explorations of green building practice in Europe and North America*. 1st ed. New York: Spon Press Taylor & Francis Group, pp. 15–30.
- FARMER, G. AND GUY, S., 2005. Reflection and engagement: towards pluralist practices of sustainable architecture. In Guy, S. and Moore, S.A. Eds. *Sustainable architectures: critical explorations of green building practice in Europe and North America*. 1st ed. New York: Spon Press Taylor & Francis Group.
- GERO, J. S., 1996. Creativity, emergence and evolution in design. *Knowledge-Based Systems*, 9(7), 435–448.

- GOUBRAN, S., 2019. Sustainability in architectural design projects – a semiotic understanding. *Social Semiotics*. Taylor & Francis, Vol. 0 No. 0, pp. 1–27.
- GRAHAM, E. M., 2003. *Studio design critique: student and faculty expectations and reality*. Louisiana State University and Agricultural and Mechanical College.
- GROBMAN, Y. J. AND NEUMAN, E., 2012. *Performatism: Form and Performance in Digital Architecture*. London: Routledge.
- GROSS, M., DO, E., 1999. Integrating digital media in design studio: Six paradigms. In: *Proceedings of the American College Schools of Architecture Conference*. Minneapolis.
- GUY, S. AND FARMER, G., 2000. Contested Constructions: The competing logics of green buildings and ethics. In Fox, W. Ed. *Ethics and The Built Environment*. London: Routledge pp. 73–87.
- GUY, S. AND FARMER, G., 2001. Reinterpreting sustainable architecture: the place of technology. *Journal of Architectural Education*. Vol. 54 No. 3, pp. 140–148.
- HAJER, M.A., 1995. *The politics of environmental discourse*. New York: Oxford University Press.
- HAZBEI, M. AND CUCUZZELLA, C., xxxx. Coherence of interior and exterior formal qualities in parametrically designed buildings. *Int. J. Design Engineering*, Vol. X, No. Y, pp.xxx–xxx.
- HOLLAND, N., 2012. Inform form perform. *Spaces & Flows: An International Journal of Urban & Extra Urban Studies*, 2(2), 177–190.
- HOSEA, B. 2019. Made by hand. In: RUDDELL CAROLINE, W. P. (ed.) *The crafty animator*. Switzerland: Palgrave Macmillan.
- KARLE, D., AND KELLY, B., 2011. Parametric thinking. *Proceedings of ACADIA Regional 2011 Conference*, 109–113.
- KAVOUSI, S., MILLER, P. A., AND ALEXANDER, P. A., 2019. Modeling metacognition in design thinking and design making. *International Journal of Technology and Design Education*. <https://doi.org/10.1007/s10798-019-09521-9>.
- Last Dance on the Main*, 2014. Directed by SOULIKIAS, A. [Film Animation]. Montreal: Mel Hoppenheim School of Cinema. <https://vimeo.com/99011728>
- LAWSON, B., 2002. CAD and creativity: does the computer really help? *Leonardo*. 35, 327–331.
- LIU, Y.-T., AND LIM, C.-K., 2006. New tectonics: a preliminary framework involving classic and digital thinking. *Design Studies*. 27, 267–307.
- LORENZO-EIROA, P. AND SPRECHER, A., 2013. Architecture in formation: on the nature of information in digital architecture. London: Taylor & Francis Ltd.
- MAHGOUB, Y., 2007. Architecture and the expression of cultural identity in Kuwait. *The Journal of Architecture*. 12, 165–182.
- MARKS, L. U., 2000. *The skin of the film: intercultural cinema, embodiment, and the senses*. Durham, NC: Duke University Press.
- MCMINN, J. AND POLO, M. 2005. Sustainable Architecture as a Cultural Project. *The 2005 World Sustainable Building Conference*. Tokyo. pp. 4537–4544.
- MIESSEN, M., 2016. *Crossbenching: Toward participation as critical spatial practice*. Berlin: Sternberg Press.
- MOOI, A. 2014. What will the architect be doing next? how is the profession of the architect evolving as the focus of society shifts from sustainability to resilience or reactivist-driven design demands? *Footprint*. No. 14, pp. 119–128.
- OXMAN, R. AND GU, N., 2015. Theories and models of parametric design thinking. *Education and Research in Computer Aided Architectural Design in Europe (eCAAe)*, Vol. 33, Vienna, Austria, pp. 477–482.

WE GAIN A LOT...BUT WHAT ARE WE LOSING?

- PALLASMAA, J., 2001. *The Architecture of image: existential space in cinema*. Helsinki: Rakennustieto.
- PALLASMAA, J., 2009. *The thinking hand: existential and embodied wisdom in architecture*. Chichester, U.K.: Wiley.
- PARKS, C. F., 2020. *Fluid frames: experimental animation with sand, clay, paint, and pixels*. Routledge.
- POLANYI, M., 2009. *The tacit dimension*. Chicago: University of Chicago Press.
- POOLE, M. AND SHVARTZBERG, M., 2015. *The politics of parametricism: digital technologies in architecture*. London: Bloomsbury Academic.
- PYLA, P., 2008. Counter-histories of sustainability. *Archis*. April, pp. 1–13.
- SCHÖN, D. A., 1987. *Educating the reflective practitioner*. San Francisco, Jossey-Bass A Wiley Imprint.
- SCHÖN, D. A., 1991. *The reflective practitioner: how professionals think in action*. Vol. 5126. Aldershot: Avebury Ashgate.
- SCHUMACHER, P., 2008. Parametricism as style: parametricist manifesto. [http://www.patrikschumacher.com/Texts/Parametricism as Style.htm](http://www.patrikschumacher.com/Texts/Parametricism%20as%20Style.htm)
- SCHUMACHER, P. AND LEACH, N., 2009. Parametricism: a new global style for architecture and urban design. *Architectural Design*. 79, 14-23.
- TARKHAN, N. (2020), Technological trajectories: assessing the role of sensing in design. In Cucuzzella, C. and Goubran, S. Eds. *Sustainable architecture – between measurement and meaning*. Wilmington, Delaware: Vernon Press. pp. 46–69.
- VANDEVYVERE, H. and HEYNEN, H., 2014. Sustainable development, architecture and Modernism: aspects of an ongoing controversy. *Arts*. Vol. 3 No. 4, pp. 350–366.
- WALKER, S., 2006, *Sustainable by design: exploration in theory and practice*. Earthscan Publications, London.
- WALKER, S., 2015, *Designing sustainability: making radical changes in a material world*. First Edit., Routledge, New York, NY.
- WOODBURY, R. F., 2010. *Elements of parametric design*. London: Routledge.

THE SERICUM VIA

A Serious Game for Preserving Tangible and Intangible Heritage of Iran

SARVIN ESHAGHI, SEPEHR VAEZ AFSHAR

*Faculty of Architecture, Department of Landscape Architecture,
Istanbul Technical University*

Email address: eshaghi18@itu.edu.tr

Email address: afshar19@itu.edu.tr

AND

GÜZDEN VARINLIOĞLU

İzmir University of Economics/Istanbul Technical University

Email address: guzdenv@gmail.com

Abstract. Efforts to preserve cultural heritage have continued throughout history, and currently use game technology. Serious games, with their audio-visual features make it possible for players to absorb and retain the often rather arid data of heritage. Furthermore, such technology facilitates the transmission of heritage globally amongst remote people, without the need to commute personally. Exploring the literature, we noted a lack of local game culture in Iran, and in the Middle East more broadly. This region is limited in terms of the existing global game industry, and the introduction of its culture to the world depends on the global market. This ascertains the paper's research problem: the need for more local games in the field to promote local historical culture. Hence, the paper aims to preserve and disseminate the tangible and intangible cultural heritage of its focus area, Iran's Silk Roads and its caravanserais, by developing and testing a serious game named The Sericum Via. It has a non-linear narrative, engaging the player in a long journey visiting the Safavid caravanserais on the Silk Roads, using their detailed information. The game's text-based and strategic environment demands decision-making skills throughout the game and is challenging enough to make the player revisit the game frequently.

Keywords. *Digital Heritage; serious game; the Silk Roads; Iran; caravanserais.*

THE SERICUM VIA: A SERIOUS GAME FOR PRESERVING TANGIBLE AND INTANGIBLE HERITAGE OF IRAN

ملخص. الجهود من أجل حفظ التراث الثقافي استمر من خلال التاريخ و الان يستخدم تقنية الالعب. الالعب الجدية مع امتلاكهم للخاصية السمعية والمرئية التي تساعد اللاعبين في امتصاص و الحصول على ماهو معروف بالمعلومات الناقصة التي تخص التراث. بالإضافة إلى أن مثل هذه التقنيات تسهل إجراء تحول التراث إلى أن يصبح عالمي بين الناس عبر الانترنت بالاغتناء عن التواصل شخصيا. اكتشاف الأدب، لاحظنا و دوننا افتقار ثقافة الالعب في ايران و الشرق الأوسط على مدى أوسع. هذي المنطقة محدودة وفقا لتواجد لمصنع الالعب العالمي . و العطاء المقدمة التي تتبع ثقافتها إلى العالم يعتمد على السوق العالمي. هذا يثبت مشكلة ورقة البحث: الحاجة إلى المزيد من الالعب المحلية في المجال من أجل نشر الثقافة التاريخية لذا البحث يهدف إلى حفظ و نشر الثقافة التاريخية الحسية أو الغير حسية. طريق سيلك ايران و المناطق التي يستريح بها السياح وقت السفر من خلال تطور واختبار لعبة اسمها سيريكوم فيا. تمتلك كتابة أو مسلك غير مستقيم تجعل اللاعب في رحلة طويلة لزيارة سافافيد كارافانسيرايس على طرق سيلك باستخدام معلوماتهم المفصلة. اللعبة مبنية على نمط كتابي و أوامر بيئية استراتجية في موهبة اتخاذ القرارات خلال اللعبة و هيا تحدي كفاية لاجل الالعب يزور اللعبة بشكل متكرر.

الكلمات المفتاحية: التراث الرقمي؛ لعبة جادة؛ طرق الحرير؛ ايران؛ القوافل.

1. Introduction

Cultural heritage, which is the inheritance from previous generations, both tangible, such as ancient objects or buildings, and intangible, such as skills, traditions, and knowledge, is in danger of perishing, and should be preserved for the sake of future generations (Marnierides et al., 2020). While efforts are made to protect the tangible heritage by moving items to museums, the intangible traditions and ceremonies become lost (Kalay, 2007). Fortunately, the emergence of novel digital media makes it possible to gather this threatened heritage into a database (Manovich, 2001). It is then possible to harmonize these data as a rational narrative via digital media, facilitating the storage of large amounts of data. Regarding cultural heritage, being able to digitalize the environments and artifacts makes it possible to manipulate them spatially and temporally. As a great implemented sample of the issue, *The Pure Land* exhibition providing the visitor a 1:1 scale experience of cave 220 and all its wall-paintings located in China on the Silk Roads, is preserving the cultural heritage via the new media (Kenderdine, 2013). Overall, the new technologies' influence changes the practice of preservation, although the fundamental task remains the same (Kalay, 2007).

Games are one type of new media that immerse their players in a virtual world. With the increasing use of gaming in everyday life, the notion of gamification is commonly used in real-world activities such as work and education. Serious or educational games are examples of how game-based learning is fast becoming a popular trend beyond leisure time (Anderson et al., 2009; Becker, 2007; De Freitas and Liarokapis, 2011). According to De Freitas and Liarokapis' (2011), gaming's educational ability is due to its

audiovisual nature, which supports the process of data absorption into the memory.

Regarding the games' teaching capacity, they could also be used to convey cultural heritage and provide players with comprehensive data through engagement with the material within the game's interface. Mortara et al. (2014) declare that games' virtual worlds can permit a wide range of people to enjoy cultural heritage remotely, in terms of space and time. Additionally, due to their transitional nature, games can migrate within various cultures, and are an outstanding sample of cultural globalization, providing cross-cultural encounters (Şisler et al., 2017). However, according to Şisler et al. (2017), the global game industry is limited to certain game market regions, and in others, local game production is underdeveloped.

This paper demonstrates the role of educational digital games in preserving the cultural heritage and globally disseminating specifically Iran's heritage through the design and testing of the *Sericum Via* game. In determining the best possible type of game for this purpose, we considered issues such as the target group and the players' desired outcomes. To understand these issues, we conducted a broad literature review about the previous work, in terms of educational games and games about Iran and the Silk Roads, and analyzed many existing games on similar topics.

2. Literature Review

Regarding previous educational games, there is a wide range of studies. *The Oregon Trail* was developed to teach elementary students about the realities and challenges of 19th-century pioneer life on the Oregon Trail and has been played almost for two decades from the mid-1980s and appears in almost all studies on this topic (Becker, 2007; Bigelow, 1997; Caftori and Paprzycki, 1997; Kane, 2020; Regalado, 2017; Slater, 2017). According to Bigelow (1997), these sorts of games are like an encyclopedia in terms of the knowledge amount and interdisciplinarity they provide, and are interactive due to the choices they offer to the players. Respecting the previous studies, Regalado (2017) assessed students' learning, resulting from the use of *The Oregon Trail* game, and Kane (2020) used a currently developed game named *The Silk Road*, using the same rules as this game, for the same purpose. Another noteworthy sample about the cultural heritage and the digital world engagement is *The Museum of Gamers* by Aydin and Schnabel (2017). They provide a digital museum experience of Kashgar, a historical town located on the silk roads, by connecting two online games using various device types. Also, an internet search on the Silk Roads and caravanserais revealed a number of games including *Silkroad Online*, *Silk Road Match 3*, *Caravanserail*, and *Caravan*.

THE SERICUM VIA: A SERIOUS GAME FOR PRESERVING TANGIBLE AND INTANGIBLE HERITAGE OF IRAN

Regarding the game industry in Iran, according to Šisler (2013), the research focused on the Middle Eastern games is limited, due mainly to the lack of game production in this region. Hence, local players are dependent on the main game industry areas. Also instanced in this study are the games Garshasp, Mir Mahna, and Age of Pahlevans, dealing with Iranian mythology and history. Additionally, some educational games are also mentioned by Šisler et al. (2017), such as the adventure game Nouruz, My Homeland, teaching children about Iran's culture and folklore, history, and archaeology. However, these games are mostly in Persian, and targeted at the local market. As declared by various game producers in this article, the industry's main purpose is to develop cultural games for export to introduce the rich culture of Iran to non-local players and avoid the possible misrepresentation of Iranians in global digital games. Concerning the existing literature, the lack of any global educational games about Iran's cultural heritage, disseminating its prosperous history and unique traditions, specifically dealing with the Silk Roads demands a wider study.

3. Methodology

3.1. HISTORY

History plays a dominant role in the process of the development of the Sericum Via game. Therefore, we investigated the relevant background regarding the Silk Roads, caravanserais, and Iran. The constant movement and intermingling of various populations affected the histories and civilizations. These journeys occurred through a network of routes and these linkages emerged as what are now known as the Silk Roads (Figure 1). Also, merchants traveling in these routes sold their cargos, or bought additional local products along their way, boosting their material wealth and variety, besides adding to the exchange of intangible heritage (UNESCO, 2020a).

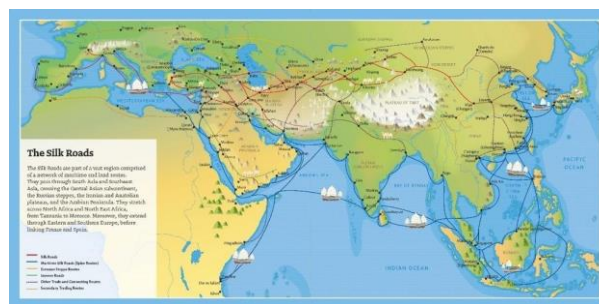

Figure 1. Map of the Silk Roads (UNESCO, 2020a).

Caravanserais were large guest houses designed to welcome merchants and their camels to facilitate people's passage and their safe travel. These caravanserais had been constructed from the 10th to the late 19th century. Caravanserais were ideally positioned within a day's journey of each other, i.e., every 30 to 40 kilometers in well-maintained areas (UNESCO, 2020a).

The history of the initial types of Persian Caravanserais goes back 2500 years (UNESCO, 2020b), but most of them had been built and restored in the early 17th, coinciding with the Safavid period, to promote the empire financially by developing the Silk Roads (Mansouri, n.d.). Therefore, for this study amongst all caravanserais of the Silk Roads, we chose that flourishing period in Iran.

3.2. DATA MANAGEMENT

Since excess of gathered data could be as problematic as its lack, it was important to understand which information should be kept, and how to complete missing data (Kalay, 2007). Therefore, the gathered data based on the international database of caravanserais (Ciolek, 1999 - present), was compared with the list of all registered cultural heritage of Iran, to understand the positions of the registered caravanserais on the Silk Roads. Due to the OWTRAD data's inaccuracy, we filtered the list of the registered cultural heritage sites by including only the provinces and cities that the Silk Roads passed through in the Safavid period (Kheirabadi, 2000). We found their accurate coordinates via an accuracy based methodology (Figure 2).

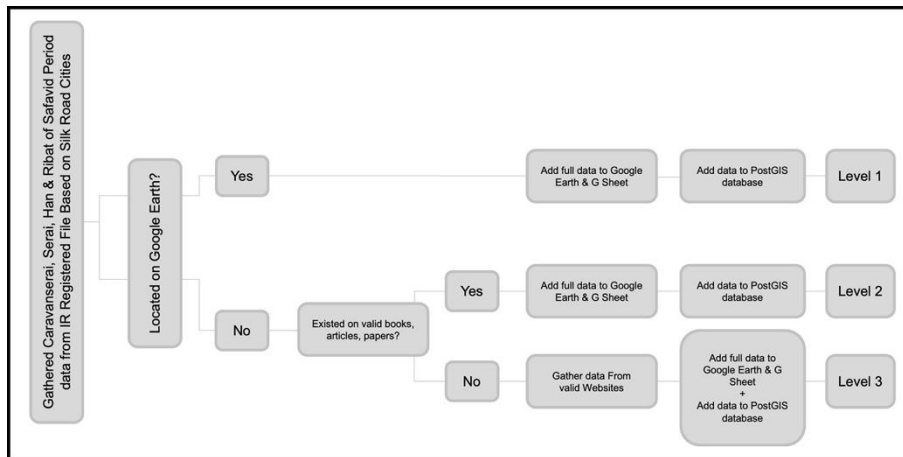

Figure 2. Data management.

Finally, we identified 104 Safavid Caravanserais on the Silk Roads in 18 provinces of Iran, located them on Google Earth, and entered all the

THE SERICUM VIA: A SERIOUS GAME FOR PRESERVING TANGIBLE AND INTANGIBLE HERITAGE OF IRAN

information on the PostGIS online database to generate a map of caravanserais. However, in the next steps, to improve the game map's readability, the number of caravanserais was decreased (Figure 3).



Figure 3. QGIS map of caravanserais.

3.3. GAME DESIGN

We designed the game inspiring by *The Oregon Trail*, considering all the gathered data in terms of tangible and intangible heritage, with player engagement. The story of the game occurs in the year 1700 AD. A merchant trading silk between Turkey and China has to pass through Iran's various climatic zones to deliver his orders to the final destination at a specific time, regardless of the road's difficulties. He seeks accommodation in the Safavid caravanserais on the Silk Roads during his journey.

The time limit given to the player was computed based on the minimum distance that GIS calculated previously between the start and endpoints. However, the player can use the GIS bonus revealing the shortest route in each gameplay. The game's learning objectives are to experience the difficulties of trading and traveling in ancient times and learn about Safavid caravanserais, the Silk Roads, and Iran's intangible heritage, i.e., ceremonies, poets, souvenirs, as well as the capabilities of GIS. Indeed, the

player encounters the caravanserias' spatial and identifying information by reaching any of them and introduced by Iran's intangible culture while confronting new local people.

As the gaming engine, we chose the Twine platform, an open-source tool for making interactive fiction games in the form of web pages (Twine, 2020) properly fitting to a text-based game. However, due to the time limitations, a part of the game was developed to illustrate the game's interface and theory, paving the way for further progress (Figures 4 and 5).

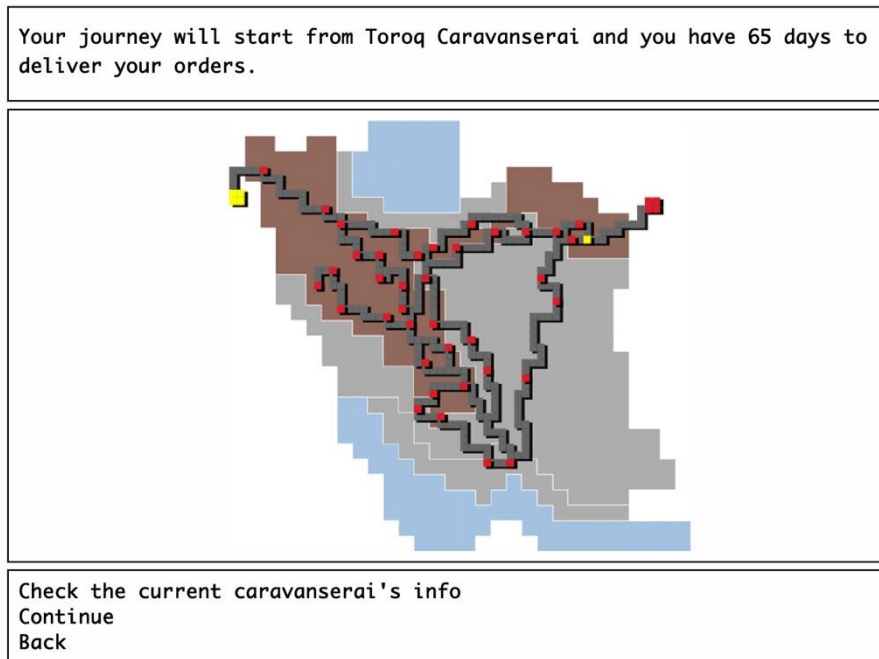

Figure 4. The overall map of the game.



Figure 5. Sample of provided intangible heritage

THE SERICUM VIA: A SERIOUS GAME FOR PRESERVING TANGIBLE AND INTANGIBLE HERITAGE OF IRAN

3. Playtesting and Survey

We conducted an open alpha playtest and survey to assemble user feedback and figure out the target audience. For this purpose, we gave two different lists of questions as Google Forms to players before and after the gameplay. The first asked for players' previous game experience and their identifying information, and the second aimed to gather the game's feedback. The survey population was 39 in total, 19 male, and 20 females. Their age range was divided into three groups, 15-20, 21-25, and 26-30 containing 8, 16, and 14 target subjects respectively, and they were further divided into two groups originated from the Middle East and Europe. Our reason for this selection was to estimate the game's possible effect on different age ranges and various nationalities as local and non-locals. However, due to the limitations, in this step we randomly selected the conductors amongst the university and high school students and asked them questions to know if the game from this research is their target or not. While 25 participants declared that they played video games, puzzle games, with 19 responses, and racing games, with 15, were amongst the most played types, played on PCs and laptops by 24 people, and mobile devices, by 29 out of 39. Furthermore, the responses demonstrate that the graphics and the game's story, and the challenging difficulties, are the prominent factors for the players in a gameplay experience (Table 1).

TABLE 1. Background assessment questionnaire graph.

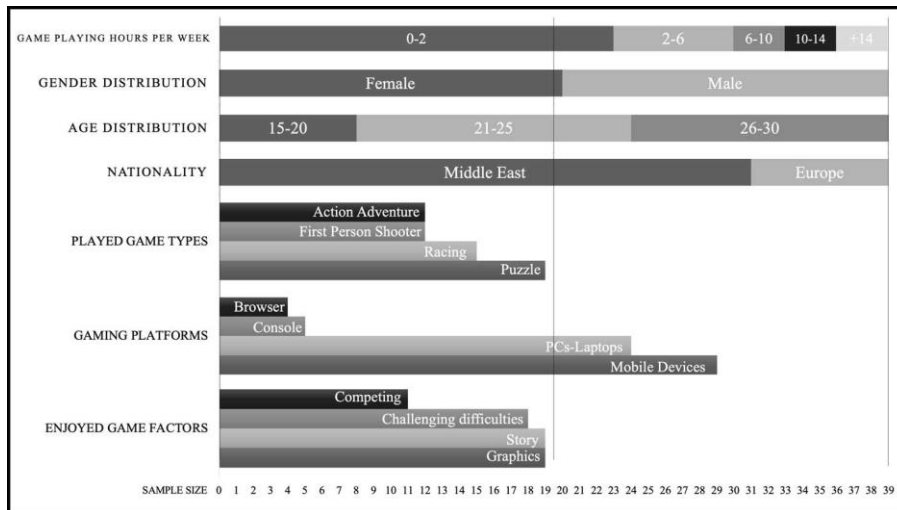

In the second questionnaire, while 27 out of 39 declared that the game caught their attention, others described it as boring with too much text.

Additionally, 23 respondents reported ignoring texts due to their length. 22 players proposed that the 11–20-year-old range was suitable for this game, and in further development, this group should be the target. In line with this finding, the storyline and the characters were reported among the game's most enjoyable factors. The surveyors gave valuable feedback about the game's interface, such as making the texts more readable, and encouraging players to read by adding some related audio, such as poems, quizzes, or mini-games using the information provided during the game. (Table 2).

TABLE 2. *The sericum via* game assessment questionnaire graph.

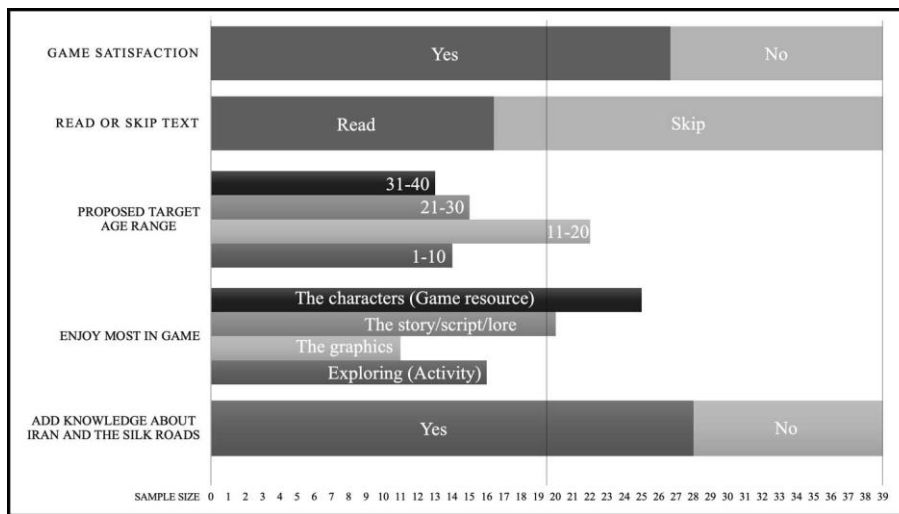

4. Conclusion

This paper discusses the role of serious games in cultural heritage preservation. Conservation of this tangible and intangible value has been important throughout history and conveying it to as many as possible is the proper way of preservation in the current global world. A serious game, such as the Sericum Via designed in this study, can provoke as much interest in children as adults in topics that otherwise may seem rather dry, such as heritage. The Sericum Via involves its players with heritage to develop their decision-making skills and increase their strategic thinking ability, besides anchoring the intended information in their mind laterally, during a leisure activity. Additionally, the game aims to transmit Iran's cultural heritage to the global market besides the local one. However, the players' surveys demonstrate that the Sericum Via needs more interactivity to draw their attention to the provided text-based knowledge during the game. The study's main limitation meant that only the alpha version was released, and the

THE SERICUM VIA: A SERIOUS GAME FOR PRESERVING TANGIBLE AND INTANGIBLE HERITAGE OF IRAN

survey results indicate that the players had no comprehensive understanding of the game theory. The future study can be conducted for the further interface and story development of the game. The selected text-based platform makes it desirable to add further features and enhance the game to the extent intended. As a joint project, the study has the future development capability to be integrated with Turkey's caravanserais' data, which the researchers gathered during the course. In this way, the game could be extended to the Silk Roads passing through Turkey, involving players in a multi-cultural, spatial, and architectural interface.

Acknowledgments

This paper is part of a doctorate course of the Architectural Design Computing Graduate Program, at Istanbul Technical University, held by Assoc. Prof. Dr. Güzden Varinlioğlu and Dr. Özgün Balaban. Also, we would like to thank Dr. Ikhwan Kim for his valuable contribution to the paper's process. Additionally, the game is available on https://drweeb.com/game/Sericum_Via.html.

References

- ANDERSON, E.F., MCLOUGHLIN, L., LIAROKAPIS, F., PETERS, C., PETRIDIS, C. AND DE FREITAS, S., 2009. Serious games in cultural heritage. *In: M. ASHLEY AND F. LIAROKAPIS ed. The 10th International Symposium on Virtual Reality, Archaeology and Cultural Heritage VAST - State of the Art Reports, 22 - 25 September Valletta, Malta*, 29-84.
- AYDIN, S. AND SCHNABEL, M.A., 2017. A Collective Intelligence Assessment Approach through Alternate Realities in 'The Museum of Gamers'. *In: Proceedings of the In-Programme Personalisation for Broadcast (IPP4B) Workshop, ACM TVX 2017 International Conference on Interactive Experiences for Television and Online Media*.
- BECKER, K., 2007. Digital game-based learning once removed: Teaching teachers. *British Journal of Educational Technology*, 38(3), 478-488.
- BIGELOW, B., 1997. On the road to cultural bias: A critique of The Oregon Trail CD-ROM. *Language Arts*, 74(2), 84-93.
- CAFTORI, N. AND PAPRZYCKI, M., 1997. The design, evaluation and usage of educational software. *In: Society for Information Technology & Teacher Education International Conference*. Association for the Advancement of Computing in Education (AACE), 23-27.
- CIOLEK, T.M., 1999 - present. *Old World Trade Routes (OWTRAD) Project*. Canberra: www.ciolek.com - Asia Pacific Research Online. [online] Available at: <<http://www.ciolek.com/owtrad.html>> [Accessed 8 November 2020].
- DE FREITAS, S. AND LIAROKAPIS, F., 2011. Serious games: a new paradigm for education?. *In: Serious games and edutainment applications*. Springer, London, 9-23.
- KALAY, Y., KVAN, T. AND AFFLECK, J. EDS., 2007. *New heritage: new media and cultural heritage*. Routledge, 17-26.

- KANE, M., 2020. A Comparison of Online and Offline Measures of Metacognition: Featuring The Silk Road Game.
- KENDERDINE, S., 2013. "Pure Land": Inhabiting the Mogao Caves at Dunhuang. *Curator: The Museum Journal*, 56(2), 199-218.
- KHEIRABADI, M., 2000. *Iranian cities: formation and development*. Syracuse University Press, 40-43.
- MANOVICH, L., 2001. *The language of new media*. Massachusetts. MIT Press.
- MANSOURI, A., EDGÜ, E. AND ŞALGAMCIOĞLU, M.E., Historic Persian caravanserais.
- MARNERIDES, D., HULUSIC, V., AND DEBATTISTA, K., 2020. High Dynamic Range in Cultural Heritage Applications. In: *Visual Computing for Cultural Heritage*. Springer, Cham, 43-62.
- MORTARA, M., CATALANO, C.E., BELLOTTI, F., FIUCCI, G., HOURY-PANCHETTI, M. AND PETRIDIS, P., 2014. Learning cultural heritage by serious games. *Journal of Cultural Heritage*, 15(3), 318-325.
- REGALADO, A.M., 2017. A Think-Aloud Assessment of Metacognition in 8th Grade Students: Using The Oregon Trail.
- ŠISLER, V., 2013. Video game development in the Middle East: Iran, the Arab world, and beyond. In: *Gaming Globally*. Palgrave Macmillan, New York, 251-271.
- ŠISLER, V., ŠVELCH, J. AND ŠLERKA, J., 2017. Video Games and the Asymmetry of Global Cultural Flows: The Game Industry and Game Culture in Iran and the Czech Republic. *International Journal of Communication* (19328036), 11.
- SLATER, K., 2017. Who Gets to Die of Dysentery?: Ideology, Geography, and The Oregon Trail. *Children's Literature Association Quarterly*, 42(4), 374-395.
- TWINE, 2020. Twine. [online] Available at: <<http://twinery.org/>> [Accessed 8 November 2020].
- UNESCO, 2020a. About The Silk Roads | Silk Roads Programme. [online] Available at: <<https://en.unesco.org/silkroad/about-silk-roads>> [Accessed 8 November 2020].
- UNESCO, 2020b. Persian Caravanserai - UNESCO World Heritage Centre. [online] Available at: <<https://whc.unesco.org/en/tentativelists/6197/>> [Accessed 8 November 2020].

A ROADMAP FOR SMART CITY IN THE ARAB REGION

A Paradigm Shift in Post-Pandemic Era

SAMAH EL KHATEEB, MANAL EL-SHAHAT

Urban Planning & Design Department, Faculty of Engineering, Ain Shams University, Cairo, Egypt

Email address: Samah.elkhateeb@eng.asu.edu.eg

Email address: manal_fathy@eng.asu.edu.eg

Abstract. A radical and rapid change in the world in the time of COVID19 pandemic powerfully brings the new era of digitalisation, and the 4th generation of the industrial revolution of Internet of Things (IoT) into practice. This raises many questions regarding the future smart city's development in Arab region: Are our cities ready for such a rapid transformation towards this digital era? Do cities have adequate infrastructure for this? What are the guidelines required to achieve Smart City (SC) models in the Arab region? The aim of this research is to assess the status quo of the new developed cities in the Arab region as models of smart cities and indicate the factors that prove their maturity and readiness for the future digital transformation in the post-pandemic era. The research methodology is an application tool on two case studies, to prove that the features and characteristics of the existing on-ground initiatives and programmes support the digitalisation movement in these two cities. The research findings are a paving roadmap for the decision makers towards efficiently functioning models for sustainable SCs in the Arab region.

Keywords: *Smart cities, Arab World, NEOM city, New Capital city, Maturity level*

ملخص. أدى التغيير الجذري والسريع في العالم في وقت جائحة كورونا إلى أن تدخل الجيل الرابع من الثورة الصناعية إلى جانب إنترنت الأشياء (IoT) إلى حيز التطبيق. وهذا يؤثر العديد من التساؤلات حول مستقبل المدن الذكية في المنطقة العربية: فهل مدننا العربية جاهزة لمثل هذا التحول السريع نحو هذا العصر الرقمي؟ هل المدن العربية لديها بنية تحتية كافية لهذا؟ ما هي الإرشادات المطلوبة لتحقيق أمثلة حقيقية للمدن الذكية في المنطقة العربية؟ الهدف من هذا البحث هو تقييم الوضع الراهن لبعض المدن الذكية في المنطقة العربية كنماذج وقياس مدى نضجها واستعدادها وجاهزيتها للتحول الرقمي المستقبلي خاصة في حقبة ما بعد جائحة كورونا. منهجية البحث تعتمد على حالة دراسية لمدينتي نيوم بالمملكة العربية السعودية والعاصمة الإدارية الجديدة في مصر وتحليل مدى جاهزيتهم

للتحول الرقمي طبقا لأداة تقييم جاهزية المدن الذكية المعد من قبل الاتحاد الأوروبي، تُعد نتائج البحث بمثابة خارطة طريق تمهد لصناع القرار الطريق نحو التحول المستقبلي للمدن العربية لتصبح مدن ذكية مستدامة.

الكلمات المفتاحية: المدن الذكية، العالم العربي، مدينة نيوم، العاصمة الإدارية الجديدة، مستوى نضج المدن وجاهزيتها لتصبح مدن ذكية.

1.Introduction

1.1 BACKGROUND

In order to better appreciate the development of Smart City (SC), it is worthwhile to briefly consider the evolution of industrial revolutions throughout three centuries of history. These Industrial Revolutions (IR) started in the 18th century with the First Revolution and was followed nearly a century later by the Industrial Revolution (known as Technological Revolution (TR) in the late 19th to early 20th centuries. The third era was the Digital Revolution (DR), which started in the middle of the 20th century with the rise of electronics, telecommunications and of course computers. This era was promptly followed by the 4th generation which started in 2011 and included major innovations such as the Internet of Things (IoT) and data mining. This played a remarkable role in formulating and altering the SC development.

Currently during the COVID-19 pandemic, the whole world is powered by virtual clouds, social media, mobile communications and internet, along with increasing screen-based data flow and exchange. Under the motto “Stay Home-Stay Safe”, the urgent appeal towards social distancing, and the restrictions of partial and complete lockdowns, people’s lifestyles have been impacted and a new digital version of the city has imposed itself.

1.2 AIM OF WORK

The paper attempts to pave a roadmap for realization of “mature” Smart City (SC) in the Arab region, while keeping up with the speed of global digital transformation, which favours active and independent systems, and adaptation into smart technologies, and thus automated reactions to changes in the built environment. The research also aims to highlight the importance of bringing the Arab region into the competition towards Sustainable Smart Cities (SSC).

A ROADMAP FOR SMART CITY IN THE ARAB REGION: A PARADIGM SHIFT IN POST-PANDEMIC ERA

1.3 RESEARCH METHODOLOGY AND ANALYTICAL FRAMEWORK

The research methodology utilises EU-Smart Cities Mapping as an analysis and measurement tool, which is to be initially adapted on two new Smart Cities in the Arab region. It will analyse features and characteristics of the existing on-ground smart initiatives that support the digitalisation process. The EU Mapping tool includes detailed analytical framework and has already been applied on 468 cities in Europe. In the current application, the researchers focus on identifying the maturity level of SC concepts in the Arab region. It is recommended to adapt the further analysis steps (refer to point 3.1) from the EU-model on Arab cases and apply it for a longer period in order to identify and gauge success, as well as build out of these cases unique SC models in the Arab region.

2. Literature Review: Digitalization and Smart City: a closer look

The era of Information Technology (IT) and World of Internet (WoI) currently dominates the entire globe. Everyone, everywhere, no matter how under privileged, nowadays own a mobile device and use internet for a variety of different functions: to communicate with others, acquire information, to navigate through online services and systems, to name but a few. The concept of SC embraces several terms that are all depending on the meanings of the word “smart”: intelligent city, knowledge city, ubiquitous city, sustainable city, digital city, etc (Cocchia, 2014). All these terms are synonyms, however, in many cases terms are used as a slogan and indicate a certain service package. Digital Cities DC focus on the delivery of e-services packages (e.g. e-tourism, e-security, e-health, and tele-care services). DC are concerned with metropolitan environments, where the Information & Communication Technology (ICT) contribute to various local socio- economic and environmental challenges (Anthopoulos & Tougountzoglou, 2012).

In this section, terms related to Digital City (DC) and Smart City (SC) are reviewed from literature. Terms such as Internet of Things (IoT), Information & Communication Technology (ICT) and Components of Smart City. Additionally, the research paper reflects on the current situation of the pandemic and how this affects and accelerates the entire process of digitalisation and “smartness” of cities’ development.

2.1 INTERNET OF THINGS (IOT)

IoT initially came from the car industry in 2003 to present the Electronic Product Code (EPC) network which can trace the flow of goods in supply chains (EPC Symposium 2003). Later, IoT became the product of the 4th industrial revolution generation that started in 2011 and refers to the network of physical objects. It contains software and sensors and allow things to be connected to the Internet and vice versa. Objects thereby interact and exchange data, as well as being remotely controlled or automated. IoT solutions may also involve cloud services and artificial intelligence (Virtudes et al 2017).

2.2 INFORMATION & COMMUNICATIONS TECHNOLOGY (ICT)

ICTs are the key medium that weaves digital intelligence into cities' urban fabric, establishing the foundation for innovating digital solutions that improve energy efficiency, optimise urban management, enhance the liveability of cities and provide new opportunities for its citizens (Ziqin & Keng, 2019). Digital infrastructure is the backbone of SC including Wi-Fi broadband and ICT devices (wireless hotspots, computing, sensors, smartphone, mobiles and networks (Townsend, 2014). A study by Cisco expects that the number of Internet-connected devices will be 50 billion by 2020 (Zanella et al 2014). Update based on Statista website; it is estimated to reach this number by 2030 (Tankovska, 2020).

2.3 SMART CITY (SC) DEFINITION

There is no single definition of SC, yet there is a various range of features and concepts. The concept of SC was coined towards the end of the 20th century during the same time of the invention of the first generation of smart phones. SC serves as an approach to sustainable cities, where resources are employed efficiently in the system. Monitoring and controlling the systems through different technologies helps better predictions of the future needs. In addition, it forcefully tackles the global urban challenges such as climate change and scarcity of resources (EU, 2015; also, Friess & Vermesan, 2013). SC concepts also include new forms of governance and public participation by ensuring accessibility to information to all their inhabitants. Intelligent decisions can be taken, and inhabitants are then able to influence the processes (see also Elkhateeb, 2018). SC makes active use of IoT, open data and the ICT infrastructure to optimise the flow of energy, people and data.

A ROADMAP FOR SMART CITY IN THE ARAB REGION: A PARADIGM SHIFT IN POST-PANDEMIC ERA

2.4 THE SMART CITY COMPONENTS

All references share the common components of SC, which includes among others transportation, buildings, health services, governments, etc. Based on numerous sources (Manville et al. 2014), six SC characteristics are defined as Smart Governance (SG), Smart Economy (SE), Smart Mobility (SM), Smart Environment (SE), Smart People (SP), Smart Living (SL) (SCIS, 2020). Nam & Pardo (2011) adopted an approach categorizing the SC components within three core factors: technological, human and institutional. The technological include physical, virtual and digital networks; the human put the social capital as a core component in the process; and finally, under institutional factors, policies, regulations and SG are integrated. Nowadays, and in the time of the pandemic, Digital Education has become an important component, where normal education systems are almost blocked, also Smart Healthcare which is predominantly geared towards outbreaks and pandemics.

Portmann and Finger (2015), in their study about aspects of SC, mentioned that in order to create an SC, individual stakeholders/groups must be provided with an inspiring learning environment in which learning is understood as the creation of knowledge (Manville et al. 2014). This means to first prepare Smart People (SP) as one of the SC components. This is not an easy task considering that the pandemic lock down has had a severe negative impact on people's psychological health; BBC news reported that depression doubled during the coronavirus pandemic (Schraer, 2020). Nevertheless, the Online platforms and social media are potential entry points for stakeholders to learn and engage (Townsend 2014). In the middle east. Social media is widespread within the locals and is highly used. This emphasised the case that social media is a potential and plays an essential role in the development of smart cities in such cultures. Manville et al. emphasised that "cities that want to be smart need good governance that facilitates the exchange of data and information".

2.5 COVID19: A PARADIGM SHIFT TO THE DIGITALIZATION AND VICE VERSA. SMART CITY AND TECHNOLOGY AS A SOLUTION FOR RISK MANAGEMENT

The urbanisation process all over the world is the momentum of SC movement. It is characterised by increasing economic competitiveness, environmental challenges; insufficient infrastructure; quickly upgrading ICT capabilities, and reducing ICT prices (Albino & Berardi, 2014; see also Höjer & Wangel, 2015 in Achmed, et al, 2018). Through a review of

research papers, web blogs and news, many authors highlighted how the pandemic is seen as a catalyst for SC, others mentioned that it is a stress test for SCs and the Digitalisation processes. Smart technologies were provided to track the movement of people under quarantine in cities, and social distancing was also tracked to help decrease spread of infections. The Covid-19 emergency is trialling our technologies, infrastructure and laws (EU, matchup Project, 2020). “High-profile projects have been scaled down or scrapped. Instead, economic recovery and digital inclusion are the focus” (Williams, 2020).

2.5.1. Smart City Technologies: A Tool for Risk Management / COVID-19

Different SC technology sectors were employed automatically in the first risk phase of the COVID-19 pandemic. Three main areas of the pandemic showed the use of smart technologies to maintain social distancing, home isolation and lockdown situations (Jaiswal et al, 2020). In many building and service sectors, digitalisation processes have been expanded and brought to use. Additionally, most of the investments made during the post pandemic era will be geared towards infrastructure sectors, enforcing a particular focus on internet and tele-communications, as well as logistics and online services. Capacity Building programmes for people on how to use online communications platforms were offered in all governmental institutions. Based on research on how smart solutions and technologies facilitated to reduce the COVID-19 risk, following smart tools highly helped the stabilisation of the system: smart healthcare, smart delivery, smart public awareness and infrastructure (Jaiswal et al, 2020).

2.5.2. Smart City Technologies SCT: A priority shift towards resilient cities / Post-COVID-19 Era

Contrary to the risk management support system for the COVID-19 pandemic listed above, some cities recognised during the pandemic the shortage in the system and the priority to shift to smart technologies. As such, COVID-19 has proven to be a catalyst for SCs. Information flow and databases, E-government systems, smart architecture, urban designs and smart open spaces are recognised as post-pandemic project packages geared towards sustainable cities.

A remarkable research in the area of risk and emergency management and resilience illustrated how SC can help face outbreaks and pandemics. The study emphasised that disease outbreaks can be proceeded as urban-related emergencies (Costa & Peixoto, 2020). The process was described as a fight against the clock, which demands serious resources and smartness from cities.

A ROADMAP FOR SMART CITY IN THE ARAB REGION: A PARADIGM SHIFT IN POST-PANDEMIC ERA

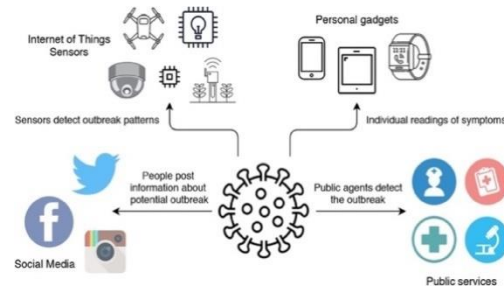

Figure 1. Outbreak should be detected in its early stages. For that, different sources of data may be exploited (Ref: (Costa & Peixoto, 2020))

In this study, transportation systems, research and innovation public services, different media institutions were acknowledged among others as the most needed resources to allow efficient communication and information flow. Three conceptual procedures are crucial within this context; detection, alerting (both must be performed as soon as possible providing information) and mitigation in the outbreak process. From the context of this study, transportation is one of the main components where the Post-Covid-19 Era and its smart cities can rely on as a solid infrastructure.

3. Application of EU SC Mapping Tool on Cities in the Arab Region

3.1 SMART CITIES EU MAPPING TOOL

EU Mapping Smart City study defines SC as a city that uses technological solutions to improve the management and efficiency of the urban environment. Europe SCs were defined based on database mapping analysis tool. A huge number of cities (468) were analysed and classified into different “smartness maturity levels”. Three entailed analysis steps were applied. Slightly over half of the 468 cities meet the European SC 2020 criteria. 240 cities with significant and verifiable SC activities were identified. The maturity level of the SCs was examined using the following categorization:

- maturity level 1: a SC strategy or policy only
- maturity level 2: in addition to level 1, a project plan or project vision, but no piloting or implementation
- maturity level 3: in addition to level 2, pilot testing SC initiatives
- maturity level 4: a SC with at least one launched or implemented initiative.

Cities that did not attain maturity level 1 did not qualify as ‘Smart’: clearly there would also be no evidence of them having any of the six characteristics. Where projects or initiatives in a SC have different maturity levels, the city as a whole was designated at the highest maturity level. (Manville et al., 2014)

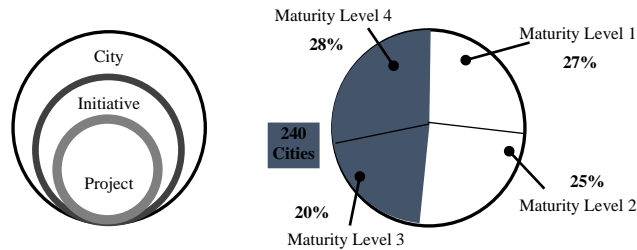

Figure 2. Results of the EU28 Smart Cities Mapping Study based on the scale and maturity. (Ref: (Manville et al., 2014; adapted by authors)

Unsurprisingly, many cities are employing relatively new SC concepts for self-promotion or as an early stage of development. Smart Environment has significantly greater representation than the other characteristics, followed by Smart Mobility. All mature SCs used a case study approach, which involves defining specific success factors (vision, people, process). Regular assessment and evaluation criteria always accompany the process.

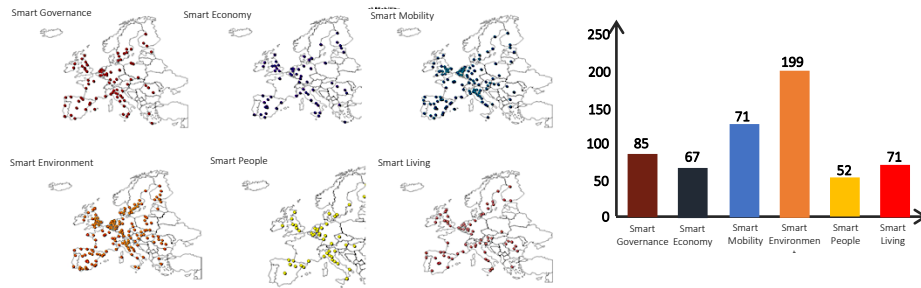

Figure 3. Smart Environment & Mobility significantly identify the 240 EU defined Smart Cities, (Manville et al., 2014)

3.2 APPLICATION ON ARAB CITIES IN EGYPT AND SAUDI ARABIA

The EU-SCs Mapping analysis tool is utilized as an application on two newly developed cities within the Arab region. The aim is to 1) identify the level of maturity of these two cases as well as 2) identify the scale and the scope of the smart projects or initiatives that give the two cases the smart

A ROADMAP FOR SMART CITY IN THE ARAB REGION: A PARADIGM SHIFT IN POST-PANDEMIC ERA

characteristic and finally 3) pave the road towards more mature cities and become one of the prominent smart cities in the post-pandemic era.

Two newly developed ‘smart’ cities from the Arab region are presented here. Neom from Saudi Arabia and the New Administrative Capital from Egypt. Both cities are in the second or third phase of the realisation of their concept that follows the smart vision oriented to their future perspectives. Both cities approach to develop international centre and hub for knowledge and businesses, targeting to accommodate population and users extending beyond the local population. Both cases’ smart projects have more or less the focus of transportation development, which can be considered as an effective base ground for further smart cities’ development.

3.2.1 Case NEOM in Saudi Arabia

Saudi Arabia announced in 2015 a 500 billion USD plan to build the futuristic megacity “NEOM”. The city should link with Jordan and Egypt. and is 300 times the size of Copenhagen. Clean and renewable energy stands on the top priority of its smart approach. It also includes water and wastewater management programmes, coastal protection, mobility, biotechnological aspects, food, hospital construction and IT solutions. The name ‘NEOM’ refers to: *NEO* is a word from the ancient Greek prefix and means *NEW*, and *M* is the first letter from the Arabic word ‘*Mustaqbal*’ which means future.

3.2.2 Case New Administrative Capital NAC in Egypt

Egypt’s New Administrative Capital (NAC) was launched in 2017 and is located 45km east of Cairo on the highway axis to the port city of Suez. The city is supposed to offer thousands of jobs and stimulate the economy. The target is to accommodate 5 million inhabitants absorbing the chronic congestion issues in the current capital. It is projected that Cairo will accommodate 40 million inhabitants in 2050.

TABLE 1. Arab ‘Smart Cities’ Cases Vision and Facts.

Arab Cases	Smart City Vision	Total area	Total cost
NAC, in Egypt The New Administrative Capital	NAC is the smart city of tomorrow. It is one of the projects of Egypt 2030 Vision. The new capital is developed with the strategic vision for a smart city integrating its smart infrastructure to provide many services to citizens. The city main function can be identified from its name as a business centre for ministries, universities as well as other economic based big companies.	170.000 acre	No information
NEOM, in Saudi Arabia New Future	NEOM is a centrepiece of Saudi Arabia’s 2030 Vision to grow and diversify the Saudi economy and position the country to play a leading role in global development. NEOM will be led, populated and funded by people from all over the world. NEOM is bold vision, a living laboratory and hub for innovation, a sustainable ecosystem for living and working, and a model for the New Future.	6548.292 acre	500 billion US dollar

3.3 DISCUSSION: SMART ARAB CITIES CASES

By initial analysing of the two cities, both cities formulated their visions to deliver big scale smart initiatives. The two cases are new-born urban centres that are still under construction and/or are currently being urbanised. In both cases the smart concepts focus on environmental and mobility initiatives and projects. City visions of NAC and NEOM include a wide range of promising smart concepts, yet no real data is available about the on-ground smart technologies or infrastructure that are integrated to prove their capacities.

TABLE 2. Analytical Framework Overview of the characteristics and impacts of smart city solutions

Smart Category	Smart Solution	Key words	Impacts	Cost Recovery
Mobility Sector: Transport and mobility (sustainable, safe and interconnected transportation systems can encompass trams, buses, trains, metros, cars, cycles and pedestrians in situations using one or more modes of transport)	Electric monorail to connect Cairo with NAC (total length 52 km with 22 stops)	Electric train – mobility apps – connectivity - travel information and routing	CO2 emission reduction by reducing travel and transit times, enhanced travel flow due to decreased time travel.	Medium return
	Hyper loop train	High speed train – smart ticket- travel information and routing	CO2 emission reduction -increase depending on public transport	Medium return
	Self-driving cars (autonomous cars)	Smart vehicle routing	CO2 emission reduction	Medium return
Environmental Sector: Smart environment (smart and renewable energy, ICT- enabled energy grids, metering, pollution control and monitoring, renovation of buildings and amenities, green building, green urban planning, as well as resource use efficiency, re-use and resource substitution are all or partially included)	Rooftop photovoltaic cells for administration buildings (64 building)	Clean energy- smart energy apps -	CO2 emission reduction	Short to medium return
	Three solar towers – solar dome	Clean energy- smart energy apps – water desalination	CO2 emission reduction	Medium return

By applying the EU analysis tool, NAC can be categorised in the maturity level 1, whereas NEOM with its huge scale renewable energy initiative that is already implemented and running can be acknowledged in the maturity level 2. Both did not reach a testing and piloting phase; thereby, the accepted maturity level is not yet reached (In the EU analysis tool, maturity level 1 and 2 were not recognised as real smart solutions). Critical points are predicted which refer to the cultural identity of the two countries.

A gap in the implementation of the smart cities vision of both Arab region cases needs to be considered. This defines the crucial need for detailed analysis of the processes of each context and system. Based on this, the researchers emphasis the need to accompany such substantial initiatives and provide enough consultation in the implementation, testing and piloting phase.

A ROADMAP FOR SMART CITY IN THE ARAB REGION: A PARADIGM SHIFT IN POST-PANDEMIC ERA

4. Conclusion:

With regards to the EU-Mapping tool, further analysis steps (review point 3.1. above) are required to be applied to the Arab region cases. However limited information about the implemented initiative of the two Arab region cases has affected the evaluation process.

It is crucial to highlight that a Smart city does not only consist of components, but also of individuals and systems. The research paper promises to provide a road map for the Arab cities towards smart cities development: the researchers thus recommend the following steps:

- Two components of SC (Smart Governance and Smart People) are essential as “drivers” for the real digitalization process. Empowering people to be part of the smart future is mandatory.
- The research advises starting by focusing on one main component and move gradually to achieve others. The research found from the literature review as well as through the review of the European case studies that Smart Mobility / Smart Transportation is the most applicable domain to start with. Mobility services are a huge Dilemma as well as a huge need in Arab cities (comparing to the European cities). This is especially in the highly populated contexts. Shared Mobility System and Smart Integrated Systems can be the answer instead of investing huge resources in high technologies in implementing for example autonomous cars. Even this area of development is still not approved from the legal and social point of view in European cities.
- Responsibility and readiness of people and basic level of technology can lead the development to another level of maturity. For this, researchers recommend relying on the already existing capacities and potentials out of the social media platforms to accelerate the process.

A gradual and focused development is the key aspect for successful smart cities development. Even famous cases of sustainable and smart cities such as Copenhagen did not achieve its goals from one step. This gradual road map for smart cities in the Arab world will help in achieving this paradigm shift in relation to the economic situation, technology level, and social aspects. Additionally, the research advice to establish a partnership between the public and private sector in order to secure the fund and smart investments from one hand and management and mentoring from another hand. Although the Arab world is different from the European cities in terms of the number of populations, economic level, climatic conditions, and social

and cultural aspects but many learnt lessons can be extracted from the European experience in smart cities and it can help in drawing the map towards smart cities in the Arab world.

5. References

- ACHMAD, K., LUKITO, L & ACHMAD, D., 2017. Smart City Readiness based on Smart City Council's Readiness Framework. Mada, Universitas.
- ALBINO, V., BERARDI, U., & DANGELICO, R., 2015. Smart Cities: Definitions, Dimensions, Performance, and Initiatives, *Journal of Urban Technology*: 22(1), 3-21.
- ANTHOPOULOS, L., & TOUGOUNTZOGLU, T.E., 2012. *A Viability Model for Digital Cities: Economic and Acceptability Factors*.
- COCCHIA, A., 2014. Smart and Digital City: A Systematic Literature Review. In: Dameri R., Rosenthal-Sabroux C. (eds) *Smart City. Progress in IS*. Springer, Cham.
- COSTA, D., and PEIXOTO, J., 2020. COVID-19 Pandemic: A Review of Smart Cities Initiatives to Face New Outbreaks. 10.1049/iet-smc.2020.0044.
- E. KHATEEB, S., 2018 "IoT architecture a gateway for smart cities in Arab world," *15th Learning and Technology Conference (L&T), Jeddah, pp. 153-160*, doi: 10.1109/LT.2018.8368500.
- HOJER M., WANGEL J., 2015. Smart Sustainable Cities: Definition and Challenges. In: Hilty L., Aebischer B. (eds) *ICT Innovations for Sustainability. Advances in Intelligent Systems and Computing*, vol 310. Springer, Cham.
- JAISWAL, R., AGARWAL, A., and NEGI, N., 2020. "Smart solution for reducing the COVID-19 risk using smart city technology," *IET Smart Cities*: 2(2). 82-88.
- MANVILLE, C., COCHRANE, G., CAVE, J., MILLARD, J., PEDERSON, J., THAARUP, R., LIEBE, A., WISSNER, M., MASSINK, R., KOTTERIN, B., 2014. Mapping Smart Cities in the EU, *European Parliament, Directorate-General for Internal Policies, Policy Department A: Economic and Scientific Policy*, Brussels.
- PARDO, T., NAM, T., 2011, Conceptualizing smart city with dimensions of technology, people, and institutions, *12th Annual International Conference on Digital Government Research, DG. O 2011, College Park, MD, USA*, DOI:10.1145/2037556.2037602
- PORTMANN, E., FINGER, M, 2015. Smart Cities – Ein Überblick!. HMD 52, 470–481 (<https://doi.org/10.1365/s40702-015-0150-4>)
- SANG, Z., and LI, K., 2019. "ITU-T standardisation activities on smart sustainable cities," in *IET Smart Cities:1 (1)*. 3-9.
- THE SMART CITIES INFORMATION SYSTEM (SCIS), update November 2020 <https://smartcities-infosystem.eu/sites-projects/projects>
- TOWNSEND A., 2014. *Smart cities: big data, civic hackers, and the quest for a new utopia*. New York: Norton & Company.
- VERMESAN, O. and FRIESS, P., 2013. *Internet of Things—Converging Technologies for Smart Environments and Integrated Ecosystems*. River Publishers, Denmark.
- VIRTUDES, A., and JOAO S., 2017, Approach of ICT Application to Governance in Urban Planning, *IOP Conf. Ser.: Mater. Sci. Eng.* 245 052086
- VIRTUDES, A., & ABBARA, A., & SA, J., 2017. Dubai: A Pioneer Smart City in the Arabian Territory. *IOP Conference Series: Materials Science and Engineering*.
- ZANELLA, A., BUI, N., and CASTELLANI, A., 2014. Internet of Things for Smart Cities, *IEEE Internet of Things Journal: 1 (1)*.

D1.P1.S4

COMPUTATIONAL ENCULTURATION II

AFFECTIVE COMPUTING IN SPACE DESIGN

A Review of literature of Emotional comfort tools and measurements.

MARIAM A. ABOUHADID

National Research Center of Egypt

Email address: m.abouhadid@gmail.com, mm.abouhadid@nrc.sci.eg

Abstract. Architecture Digital Platforms are capable of creating buildings that provide comfort that meets human thermal, acoustic and visual needs. However, some building technologies can choose the physical energy arena of the building on the expense of the mentioned aspects of human comfort. Nevertheless, aspects like emotional and psychological human comfort exist in limited studies practiced in interior design, or in active design of public spaces and on the landscape and urban scale. It is not mandatory in building design: How different spaces affect humans and what makes an environment stressful or not. Study gathers literature theoretically and categorizes it per topic: 1) Affective computing Introduction and uses, 2) Human responses to different stimulus and environments, 3) Factors that affect humans, 4) Technologies like brain imaging and Galvanic Skin Response (GSR) that are used to measure human anxiety levels, as well as blood pressure and other indications on the person's well-being, and some 5) Case Studies. Affective computing can be an addition to different pre- design analysis made to a project. Different areas of comfort like space dimensions, height, colour and shape can be the start of coding "Human Comfort" analysis software. Study has been restricted to previous research, and can be expanded further to experimentation. Future work aims to code it into Building Information Modelling Software.

Keywords: *Affective Computing; Space Design; Emotional Comfort; Human Architecture, Neuro-Architecture, Architectural psychology.*

ملخص. أثناء تصميم المكان أو المبنى ، وضع المهندسون في الاعتبار عوامل مثل الراحة الحرارية والاستقرار الهيكلي وعلم الجمال. يتم ترك عوامل مثل العواطف البشرية ومستويات الإجهاد في الكثير من الأحيان. يجمع البحث ما تم رصده في رد الفعل العاطفي للمستجيبين لتصميم المساحات المختلفة ، من خلال التجارب البدنية والاجتماعية والمسح. ثم يحدد العوامل التي أثرت على المشاركين وأثار ردود فعلهم أثناء تحليلها. يرصد البحث التحقيق في ردود الفعل العاطفية للمستخدمين لإعداد تصميم الفراغات المختلفة ، من خلال التجارب الفيزيائية و الاستقصائية. تعريف العوامل التي تؤثر على ردود أفعال المستخدمين

AFFECTIVE COMPUTING IN SPACE DESIGN: A REVIEW OF LITERATURE OF EMOTIONAL COMFORT TOOLS AND MEASUREMENTS

الفراغ المعماري. يهدف البحث الي دراسة مستقبلية لتصميم العوامل التي تؤثر على تصميم المساحة والراحة العاطفية ليتم ترميزها في الدراسات القادمة في برامج نمذجة معلومات البناء BIM.

الكلمات المفتاحية: الحوسبة الانسانية، تصميم الفراغ، الراحة الانسانية، العمارة الانسانية، العمارة العصبية، علم النفس في العمارة.

1. Introduction

Affective computing describes using computers in ways that track and decipher humans' emotions, hence be able to generate products that are more appealing to the human psyche. Applying the emphasis of Picard and Klein (2002) on the importance of emotional needs, an important function and purpose of emotional design emerges. That is, emotional design can contribute to the wellbeing of the receptors by taking into account and helping to fulfil their emotional needs. According to Picard and Klein (2002), these needs include empathy and self-awareness, feeling connected to others and understood and accepted by them. (Plass J. et al., 2016)

The basic physiological human needs include the shelter as per Maslow's pyramid. The need for safety comes next with the sense of stability and security. There is a built-in human reaction to threats from the environment, and structures threaten our primeval sense of security when they appear unnatural. A building, regardless of shape or use, is perceived as beautiful when an emotional link is established with the structural order. (Salingaros N., 1995)

In his Book, Places of the soul, (Day C., 2014) the author states that Animals unvaryingly respond to environmental stimuli, whereas humans have the ability to transcend the situation. Most people tend to react to stimuli in predictable ways. Architectural psychology studies the environmental requirements of places in which we can feel good, private, sociable, and so on. Without constant stimulus human senses wither. Inadequate stimulation makes life boring, joyless and uninspiring – but too much can be alarmingly over-stimulating. So Day C. (2014) advice for a stress-free life is that people need sameness, predictability; but to feel alive, their senses need contrast and stimulus. Psychologists call this 'difference within sameness'.

(Keniger L. et al.,2013) acknowledges the fact that Growing body of research shows that building environments that connect people to nature are more supportive of human emotional well-being and cognitive performance than environments lacking these features. Access to indoor sunlight is also associated with perceived cheerfulness of the environment as well as higher levels of positive affect and job satisfaction for the occupants. There is evidence also that daylight and indoor sun may be beneficial to building occupants who experience Seasonal Affective Disorder (SAD) which leads to lowered energy and moods in winter months. (Keniger L. et al.,2013)

For most of human history, people have actively adjusted the environment as well as their behaviors to achieve comfort. Yet buildings continue to be designed with a "one size fits all" approach. (Heerwagen J., 2008)

2. How the Environment affects Humans

Schools of architecture over decades have been influenced by social and political events, and have shown major transformations. (Heerwagen J., 2008). According to (Salingaros N., 1995) *The Emotional Basis of Architecture* Successful buildings have one overriding quality: they are natural and comfortable.

(Salingaros N., 1995) who studies *The Laws of Architecture from a Physicist Perspective* states that modernist structures make their inhabitants feel very uncomfortable. Something vital in human consciousness could well be damaged by an environment that lacks structural order. Research states that modernist architecture deliberately opposes nature. This violates deeply-seated feelings that are an intrinsic part of human consciousness.

Fear, Anxiety, estrangement, and their psychological counterparts, anxiety neuroses and phobias, have been intimately linked to the aesthetics of space throughout the modern period. (Vidler A., 2000). Modernism has introduced many spatial fears to psychoanalysis, forming its notions of abstractions under the sign of neurasthenia and agoraphobia.

2.1. HOW SPACE DESIGN AFFECTS USERS' EMOTIONAL STATE

Relaxation and stress monitoring is a well-covered area in usability, ergonomics and human-computer interactions (HCI). According to (Motte D., 2009) an emotion can be defined as "a relatively brief episode of coordinated brain, autonomic, and behavioural changes that facilitate a response to an external or internal event of significance for the organism."

(Day C., 2014) explains in his book "Places of the soul", that architectural drawings do not transfer the real humans' feeling experiencing a space. It might represent it but the lines cannot define how the user will react to them in reality. Sharp edges and round corners do not affect humans the same way. "Nothing alive ever fits exactly in any hard-edged category", Explains (Day C. 2014). Design by placing coordinates on a grid may make things easy to measure, but it describes the world in a non-human, more machinery type of environment. It's evident that a world made up only of rectangles is death to the soul. Hard mineral matter, hard lines, hard corners, repetitive unambiguous form, these patterns alienate humans as it is not how they were meant to live in.

When the Bauhaus movement so enshrined the geometric solids cube and cylinder, it was also choosing the most economical forms for the machine age. Bauhaus derivative buildings that followed were increasingly shaped by

AFFECTIVE COMPUTING IN SPACE DESIGN: A REVIEW OF LITERATURE OF EMOTIONAL COMFORT TOOLS AND MEASUREMENTS

monetary criteria. Machine extruded forms aren't places for living occupants, only for mechanical bodies. Such rooms can easily feel like boxes: uncomfortable, claustrophobic and life-suppressing. When (Day C., 2014) refers to Classical architecture, he found that it always grew from bases. Vernacular walls invariably widened at the foot, usually with a two angle flare. Such walls are more solid, rooted in the earth, more timeless, quiet, reassuring and restful than those exactly vertical, which according to the author are just parked there.

Free curves, in other words, are mood-enlivening and life-enhancing but can lull us into a dreamy state, forgetting the practicalities of the real world. In contrast, straight lines are 'businesslike'. Easy to understand, they help us think clearly. This makes them lines of organization, often of power. A balanced, healthy human life lies somewhere between these two extremes. (Day C., 2014)

2.2. ARCHITECTURAL ELEMENTS THAT AFFECT HUMANS COMFORT

Some Architectural Elements promote relaxing effects into human brains; they can transform the mental state into a state of mindfulness and consciousness. Meditation is a spiritual practice that can be reached into an environment that has those elements. By using those elements, humans can be more relaxed and focused and less stressed and anxious. (Keng S. et al., 2011). Nature has fortunately provided an intuitive guide to habitat quality (The Savannah theory is an example of that). Positive emotional states of interest and pleasure, associated with preference, signal that an environment is likely to provide resources and supports that promote survival and well-being, while negative affective states serve as warnings of potential harm or discomforts. (Heerwagen J., 2008).

According to literature, Stimulus in a built environment can lie anywhere between the lines and shapes of the space, lighting (windows size, shape, position), Ventilation (Thermal Comfort), Acoustic comfort, Visual comfort, colors of walls and interior fixtures. (Yu Lau S., 2014), in order to achieve moderate or appropriate stimulation, layout, circulation, control, flexibility, responsiveness, privacy, spatial syntax, defensible space and certain symbolic elements are key architectural factors. Insufficient spatial resources, inflexible spatial arrangements, and lack of climatic controls, all threaten individual needs to effectively interact with the space.

3. Human indicators to emotional response

In the old times, humans' surroundings were full of dangers that can end their lives. Animals, natural disasters, lack of food or any predator attacks. A natural response to danger, that is engraved in humans nervous system is the

fight or flight response. They either face and fight the danger or run away from it to save their lives. In modern times, dangers become different and less occurring, but the brain memory kept the same kind of reflexes. When a person is faced with a stressful situation, his brain translates it as “danger” and automatically turns on his “fight or flight” response. (Law A. et al., 2008)

This causes what is known now as “Anxiety”, that shows by many symptoms like quick palpitations, high sweat levels, numbness of hands or feet, headaches, shortness of breath and other symptoms. Anxiety symptoms used to fade away when the source of perceived danger disappears; however, in modern societies, the symptoms persist due to the stressful nature of fast-paced modern living, over-thinking and lack of relaxing environments.

The built environment might be playing a role in increasing anxiety and related phobias. And pre-design process has included lots of factors to secure a comfortable environment for the users like environmental thermal analysis. But physiological and psychological factors remain unmeasured and uncontrolled in modern cities. (Bourne E., 2010).

(Cisler J. et al., 2010) gave some examples to the factors that can be measured to test the person’s emotional state at a specific moment, or under certain circumstances. Indicators included: Heart rate, blood pressure, anxiety related problems like phobias: agoraphobia, claustrophobia, obsessive compulsive disorder OCD, generalized anxiety disorder, panic disorder, post-traumatic stress disorder PTSD, selective mutism, depression or anxiety levels (General anxiety, panic, social anxiety), anger, irritability, or restlessness, feeling overwhelmed, unmotivated, or unfocused, trouble sleeping or sleeping too much, racing thoughts or constant worry, problems with your memory or concentration, making bad decisions. Other physio-psychological cases include seasonal affective disorder (SAD), where symptoms can include mood swings and seasonal depression.

Sick Building Syndrome SBS/ Tight Building Syndrome where symptoms include headache, dizziness, nausea, eye, nose or throat irritation, dry cough, dry or itching skin, difficulty in concentration, fatigue, sensitivity to odors, hoarseness of voice, allergies, cold, flu-like symptoms, increased incidence of asthma attacks and personality changes. (Wargocki P. et al., 2000)

4. How to measure Emotions?

Desmet et al. wrote that: “Psychophysiological instruments measure typical physiological reactions that come along with emotions, such as changes in heart rate or pupil dilatation.” These measures cannot be used to distinguish emotions since they only indicate the amount of arousal that is part of the emotion. Moreover, emotions of low intensity are difficult to assess with these measures.” Psychophysiological measurement techniques permit the immediate and continuous measurement of the bodily reaction to an

AFFECTIVE COMPUTING IN SPACE DESIGN: A REVIEW OF LITERATURE OF EMOTIONAL COMFORT TOOLS AND MEASUREMENTS

emotional stimulus. They bypass the subjectivity and ambiguities of self-reports and allow for a precise matching between the emotional trigger and the emotional reaction. (Motte D., 2009)

4.1. SUBJECTIVE (PSYCHOMETRIC) MEASUREMENT TOOLS

As stated in (Kolakawska A. et al., 2015, Hosany S. et al., 2015), in the field of psychology various emotions representation models have been defined. They can be used in emotion modelling for affective applications. Four commonly adapted scales include Plutchik's (1980) eight primary emotions, Izard's (1977) Differential Emotion Scale, Mehrabian and Russell's (1974), Pleasure, Arousal, and Dominance Scale (PAD), and Watson, Clark, and Tellegen's (1988) Positive Affect and Negative Affect Scales (PANAS). Other Tools like the OCC Componential Model, Geneva Emotion Wheel (GEW), Self Assessment ratings and whissell wheel.(Kolakawska A. et al., 2015), Self-Reports of Emotional State, Behavioral Observation, Neighborhood Social ties test (Cisler J. et al., 2010).

According to (Homolja M. et al, 2020) Numerous studies have noted that emphatically measuring emotion is difficult; quantifying a very subjective emotive experience is an inherently complex task and subjective methodologies alone are argued to have limited effectiveness.

Emotion is reflected in all modes of human communication such as word choice, tone of voice, facial expression, gestural behavior, posture, skin temperature and clamminess, respiration, muscle tension, and more (Picard et al. 2001). Picard et al. (2001) elaborate on how emotional recognition systems are most likely to be accurate when they combine multiple kinds of signals from the user with information about the user's context, situation, goals, and preferences. (Picard et al. 2001).

4.2. OBJECTIVE MEASUREMENT TOOLS

Many measurement tools include:

- A. Galvanic Skin Response (GSR/EDA): Electrodermal activity (EDA), also referred to as galvanic skin response (GSR), reflects the amount of sweat secretion from sweat glands in our skin; increased sweating results in higher skin conductivity. (GSR, Imotions, 2017)
- B. Electroencephalography (EEG) Technologies: Electroencephalography (EEG) is an electrophysiological monitoring method to record electrical activity of the brain. It is typically non-invasive, with the electrodes placed over the scalp, thus suitable also for no-laboratory settings. (EEG, Imotions, 2017). Unlike facial recognition, EEG is able to monitor the global emotional state of a person, which cannot be controlled consciously. Combining the two modalities allows getting insights into both the moment-

- by-moment changes in emotional expression as well as variations in emotional states across a longer time span. (EEG, Imotions, 2017)
- C. Augmented Reality (AR) can aid in visualizing building projects. Architecture sight-seeing can be enhanced with AR applications, allowing users viewing a building's exterior to virtually see through its walls, viewing its interior objects and layout. (Mane C. et al., 2020). Microsoft Hololens is an example to gadgets that use Augmented Reality to give the user a virtual reality experience of a product, space, game or any other not- real environment. (Kalantari M., 2017)
 - D. Electromyographic sensors (EMG) sensors monitor the electric energy generated by bodily movements of the face, hands or fingers, etc. (startle reflex). Also, facial EMG can be used to track smiles and frowns in order to infer one's emotional valence. (Experimental Design, Imotions, 2017)
 - E. Electrocardiography and Photo-plethysmography (ECG/PPG) Track heart rate, or pulse, from ECG electrodes or optical sensors (PPG) to get insights into respondents' physical state, anxiety and stress levels (arousal), and how changes in physiological state relate to their actions and decisions.
 - F. Complementing facial expression analysis with eye tracking, GSR or EEG allows you to get insights into both the valence (quality) of an emotional response as well as the amount of arousal (intensity) it triggers in your respondents. (GSR, Imotions, 2017)

As Picard and Klein (2002) suggest, addressing the user's emotional needs does not require the computer to have the emotional qualities of a human being. The emotional needs of the human user can still be addressed and at least partially fulfilled during the interaction with the program, even when the user is aware that the agent with whom they are interacting is not a human being. Significant developments in this direction can be seen as functions of "the recent shift from computers as tools to computers as partners and socially intelligent agents, and intelligent decision-aids". Consistently, the field of affective computing is flourishing, with many projects toward "building machines that have several affective abilities, especially: recognizing, expressing, modelling, communicating, and responding to emotion". (Plass J. et al., 2016)

5. Case Studies of measuring emotions in Space design

Different Research used the above mentioned methods to evaluate the users and designers' emotional state towards different settings. A recent study (Gero J. et al., 2020) used physiology measurements like eye-tracking, electrodermal activity (EDA), heart rate, and emotion tracking (facial expression analysis), EEG, FNIRS (Functional Near infrared Spectroscopy) and FMRI (Functional Magnetic Resonance Imaging) to evaluate the designer state in different phases of the design process. Another study by

AFFECTIVE COMPUTING IN SPACE DESIGN: A REVIEW OF LITERATURE OF EMOTIONAL COMFORT TOOLS AND MEASUREMENTS

(Banaei M. et al., 2019) conducted an experiment using immersive VR, to make the sample experience different space designs and answer a set of questions on a scale from 1 to 5 according to how they feel about the design and how comfortable they find it.

Banaei M. et al., (2017) worked on creating different virtual environments. Then with Virtual reality, immerse the sample into the created environment. The sample's body was connected to EEG cap to measure the brain activity according to each design. Some designs were more stimulating than others. Another recent study (Zou Z. et al., 2019) has tried to develop a new framework to bring an understanding of architecture and neuroscience interactions in designed facilities and quantification of the impact of design on the human experience. The authors first built two virtual environments (i.e., restorative and non-restorative) using the architectural design features related to human restorativeness identified by previous research efforts. They compared multiple design variables with the use of windows and light to understand how humans react to such spaces. The participants were asked to conduct navigational tasks while their bodily responses were recorded by body area sensors (e.g., EEG, GSR, and Eye-tracking). The result showed that human responses in restorative and non-restorative environments had statistically significant difference.

In their study, Banaei M. et al. (2019) investigated the effects of different interior architectural forms on emotional states by considering personality traits. This work also filled four main gaps found in previous studies by using comprehensive interior form clustering, analyzing forms in real combinations, allowing participants to explore 3D forms in VR, and considering different personality traits in design. The results illustrated the relationship among different forms, emotional states, and personality traits. Additionally, this study further examined the means of researching 3D-built environments in VR. The participants used VR to perceive space actively, and this study innovatively explored environmental psychology in interior architecture.

Another project entitled: "Decoding the Emotions of an Architectural Experience" (Homolja M. et al, 2020) made a pilot study in the elements of architecture, the ways they affect humans and how they were measured. A few studies investigated the relationship between architectural form and emotion. Some of these studies sought to define curved lines with adjectives like "serene", "graceful", and "tender-sentimental", and described angles as "robust", "vigorous" and "somewhat more dignified". Another Study concluded that having too many curved forms could cause stress. (Banaei M. et al., 2017)

Numerous studies have shown a covariation of pleasant feelings associated with curved forms. In his thesis, Nejad M.K. (2007), created different set of virtual environments, and tested their effect on his subjects. His sample included different genders, architects and non-architects, results suggest that pleasantness, relaxing, and friendliness variables are correlated. If we

assume that spaces that are considered pleasant are more preferred, mystery had a much lower correlation to preference as was found in previous studies.

6. Study Limitations

Study has been restricted to found literature, and can be expanded further to experimentations. Methods of measuring Human stimulus and reactions include Subjective measurement tools tests were not included in this study. Also Statistical methods and software of data analysis were not included in this review.

7. Conclusion and Future Work

The design of many products often involves human responses and behavioural expectations, like games, logos, cars, devices, etc. Buildings design might as well be perceived as a product to serve humans and target their well-being. It is important that though design and architecture have an aesthetic appeal, to make sure that it is more than just looks. It affects mood, behavior, and overall quality of life. This review was done to establish if the current body of research has shown evidence linking the built environment to altered emotional states. The evidence base of this is growing as well as the need to understand if we can support mental health and wellbeing through environmental exposure. Architecture combined with neuroscience and behavioral sciences can only be enhanced with human behavior research. Working across disciplines allows for a better understanding of the characteristics of design and how it can affect human behaviour and emotions.

The translation of human need and implementation into the design process can only be done with the help of technology, starting with measurement tools presented in this study, till the platforms and software that can further develop this mechanism into more automated and systematic studies like thermal comfort analysis software.

Future work aims to code human emotional responses into Building Information Modelling Software. Affective computing can be an addition to different pre- design analysis made to a project on using a BIM platform. Different areas of comfort like space dimensions, height, color and shape can be the start of coding “Human Comfort” analysis software.

8. References

BANAEI M. ET AL., 2017, Walking through Architectural Spaces: The Impact of Interior Forms on Human Brain Dynamics. *In: Frontiers in Human Neuroscience*.

AFFECTIVE COMPUTING IN SPACE DESIGN: A REVIEW OF LITERATURE OF EMOTIONAL COMFORT TOOLS AND MEASUREMENTS

- BANAEI M. ET AL., 2017, Application of AI methods in the clustering of architecture interior forms. *In: Frontiers of Architectural Research.*
- BANAEI M. ET AL., 2019, Emotional evaluation of architectural interior forms based on personality differences using virtual reality. *In: Frontiers of Architectural Research.*
- BOURNE E., 2010. The Anxiety and Phobia Workbook. *In: New Harbinger Publications, Inc., Canada.*
- CISLER J. ET AL., 2010. Emotion Regulation and the Anxiety Disorders: An Integrative Review. *In: Journal of Psychopathological Behavior Assessment: 32(1): 68–82.*
- DAY C., 2014. Places of the Soul: Architecture and Environmental Design as a Healing Art. *In: Routledge, Taylor and Francis.*
- GERO J. ET AL., 2020. A framework for studying design thinking through measuring designers' minds, bodies and brains. *In: University of North Carolina at Charlotte & AAU CRENAU. Graduate School of Architecture Nantes.*
- HEERWAGEN J., 2008. Psychosocial Value of Space. *In: J.H. Heerwagen & Associates, Inc., Last updated: 05-23-2008*
- HOMOLJA M. et al, 2020. The impact of moving through the built environment on emotional and neurophysiological state, a systematic literature review. *In: Conference: RE: Anthropocene, Design in the Age of Humans, At: Bangkok, Thailand.*
- HOSANY S. et al., 2015. Measuring Tourists' Emotional Experiences: Further Validation of the Destination Emotion Scale. *In: Journal of Travel Research, Vol. 54(4) 482–49.*
- KALANTARI M. ET AL., 2017. Exploring the Early Adopters of Augmented Reality Smart Glasses: The Case of Microsoft HoloLens. *In: Springer, 229- 246.*
- KENG S. ET AL., 2011. Effects of Mindfulness on Psychological Health: A Review of Empirical Studies. *In: Clinical Psychology Review: 31(6): 1041–1056.*
- KNIGER L. ET AL., 2013. What are the Benefits of Interacting with Nature? *In: International Journal of Environmental Research and Public Health, 10, 913-935.*
- KOLAKOWSKA A. et al., 2015. Modeling emotions for affect-aware applications. In: book: Information Systems Development and Applications. Chapter: 4. Publisher: Faculty of Management University of Gdańsk. Editors: Stanislaw Wrzycza.
- LAW A. ET AL., 2008. Both Predator and Prey: Emotional Arousal in Threat and Reward. *In: Psychological Sciences: 19(9): 865–873.*
- MANE C. ET AL., 2020. AR Based Structure Design and Model Development for Construction Application. *In: International Research Journal of Engineering and Technology, Volume: 07 Issue: 06.*
- MOTTE D. 2009. Using brain imaging to measure emotional response to product appearance. *In: Proceedings of the 4th International Conference on Designing Pleasurable Products and Interfaces – DPPI.*
- NEJAD M. K., 2007. Curvilinearity in Architecture: Emotional Effect of Curvilinear Forms in Interior Design. Texas A&M University, Texas, TX.
- PICARD R. ET AL., 2001. Toward Machine Emotional Intelligence: Analysis of Affective Physiological State. *In: IEEE Transactions on Pattern Analysis and Machine Intelligence 23(10)*
- PICARD R. ET AL., 2002. Computers that recognize and respond to user emotion: theoretical and Practical implications. *In: Interacting with Computers, Volume 14, Issue 2, 141-169.*
- PLASS J. ET AL., 2016. Emotional Design in Digital Media for Learning. *In: Emotions, Technology, Design, and Learning, Edition: 1 Chapter: Emotional Design in Digital Media for Learning, Elsevier.*
- SALINGAROS N., 1995. The Laws of Architecture from a Physicist Perspective. *In: Physics Essays 8, 638-643, University of Texas, USA.*
- VIDLER A., 2000. Warped Space: Art, Architecture and Anxiety in Modern Culture. *In: MIT Press.*

M. ABOUHADID

- WARGOCKI P. et al., 2000. The Effects of Outdoor Air Supply Rate in an Office on Perceived Air Quality, Sick Building Syndrome (SBS) Symptoms and Productivity. *In: Indoor Air 10(4):222-36.*
- YU LAU S., 2014. Healthy campus by open space design: Approaches and guidelines. *In: Frontiers of Architectural Research 3, 452–467*
- ZOU Z. ET AL., 2019. A Framework towards Quantifying Human Restorativeness in Virtual Built Environments. *In: Department of Civil and Urban Engineering, New York University, 15 MetroTech Center, Brooklyn.*
2017. EEG, The Complete Pocket Guide. *In: Imotions Biometric Research Guide, Imotions.*
2017. Experimental Design, The Complete Pocket Guide. *In: Imotions Biometric Research Guide, Imotions.*
2017. Galvanic Skin Response (GSR): The Complete Pocket Guide. *In: Imotions Biometric Research Guide, Imotions.*
2017. Human Behavior, Pocket Guide. *In: Imotions Biometric Research Guide, Imotions.*

استخدام برنامج ENVI-met لمحاكاة السلوك المناخي للعنصر الأخضر داخل الفراغات العمرانية

أحمد فكري، ريهام الدسوقي

قسم الهندسة المعمارية

كلية الهندسة جامعة القاهرة

البريد الإلكتروني: Dr.ahmedfekry@gmail.com

قسم الهندسة المعمارية

كلية الهندسة جامعة بنى سويف

البريد الإلكتروني: Dr.reham@aucegypt.edu

و

مى عبد العاطى

قسم الهندسة المعمارية

كلية الهندسة جامعة المستقبل

البريد الإلكتروني: maiabdlaty@gmail.com

ملخص. البيئة العمرانية ما هي إلا ناتج التفاعل الدائم بين العناصر المادية المكونة للفراغ العمراني والعوامل المناخية، فالعلاقة بينهما تشبه المعادلة الكيميائية؛ ومن هنا تأتي صعوبة التوقع والتعامل مع هذه العلاقات المعقدة؛ ونتيجة لذلك لجأ المصممون إلى استخدام برامج المحاكاة؛ فقد وجد على المصممين في مجال التصميم العمراني أن يكونوا على دراية كاملة بطرق استخدام هذه البرامج واستخدامها الاستخدام الأمثل، والتحقق من مدى تأثير استخدام العنصر الأخضر داخل الفراغ العمراني بصورة مسبقة أثناء عملية التصميم قبل التنفيذ على أرض الواقع. ومن هنا تهدف الورقة البحثية إلى محاولة دمج بين كل من: التصميم العمراني للفراغات العمرانية، وبرامج محاكاة السلوك المناخي؛ وذلك عن طريق اللجوء إلى استخدام أحد برامج محاكاة السلوك المناخي (برنامج: ENVI-met)، وتحديد مدى تأثير استخدام النسبة المثلى للعنصر الأخضر في الفراغات العمرانية محل الدراسة (فراغ عمراني بالجامعة الأمريكية بالقاهرة الجديدة، وفراغ عمراني بجامعة الأميرة نورة بالرياض) على الراحة الحرارية لمستخدمي الفراغ.

الكلمات المفتاحية: العنصر الأخضر، ENVI-met، محاكاة السلوك المناخي، الفراغات العمرانية.

1- المقدمة :

إن العنصر الأخضر إذا ما أحسن اختياره وتصميمه أصبح له دور هام في خلق مناخ لطيف من خلال دوره كعنصر أساسي في تصميم الفراغات العمرانية؛ فإن تصور النباتات والأشجار الواقعية بواسطة الكمبيوتر أمر يثير اهتمام أمر مجموعة كبيرة من المستخدمين والباحثين، ولتوليد وإنشاء

النباتات بواسطة الكمبيوتر يجب مراعاة اختلاف مناهجها الحسابية (Helge , Tim and Michael , 2020)

فكل نبات له تأثير على العناصر المناخية في أي فراغ عمراني، ويتوقف ذلك التأثير على حجمه وكثافته ومرونته؛ فالنباتات هي أكثر عناصر الفراغ العمراني فاعلية في تأثيرها على حركة الرياح - ودرجة الحرارة - ونسبة الرطوبة - ونسبة الإشعاع الشمسي، بجانب قدرة النباتات على تخفيف آثار الجزر الحرارية الحضرية (Heat urba island) من خلال عملية البخر والنتج والتظليل؛ مما يؤدي إلى انخفاض درجات الحرارة (Helge et el, 2018) .

وللتأكد من تحقيق هذه الأهداف كان يجب اللجوء إلى المعايير الحديثة من خلال الاستعانة ببرامج الحاسب في عملية التصميم، وقد تم استخدام أحد هذه البرامج؛ وهو برنامج ENVI-met ومن هنا فقد تم في هذه الورقة البحثية تقييم السلوك المناخي لكل من: فراغ عمراني بالجامعة الأمريكية بالقاهرة الجديدة، وفراغ عمراني بجامعة الأميرة نورة بالرياض، واقتراح النسبة المثلى من العنصر الأخضر لكل من الفراغين محل الدراسة، مع مراعاة الظروف المناخية الخاصة بكل فراغ على حدة؛ بهدف الوصول لأفضل قدر من الراحة الحرارية لمستخدمي هذه الفراغات؛ وذلك عن طريق إجراء العديد من محاولات المحاكاة باستخدام برنامج (ENVI-met).

2- استخدام برامج محاكاة السلوك المناخي للفراغات العمرانية

إن أدوات تقييم السلوك المناخي مهمة للغاية في تقدير النطاقات المختلفة المؤثرة في التصميم المناخي العمراني الذي يتألف من نطاقات مختلفة والتي يجب مراعاتها أثناء عملية التصميم التي تؤثر فيه بشكل مباشر، و في ما يلي نبذة مختصرة عن بعض البرامج المختصة لمحاكاة السلوك المناخي العمراني ، (جدول- 1) والأكثر تناسبا مع موضوع الدراسة .

(Yung, Tzu and Andreas, 2014 ; Andreas, 2012 ; Dalong, Xiaowei and Wenqin, 2019 ; <https://www.envi-met.com>)

الجدول 1 : شرح مختصر لبعض برامج محاكاة السلوك المناخي للفراغات العمرانية.

اسم البرنامج	شرح مختصر لمواصفات البرنامج
RayMan	- برنامج مجاني . - يتميز البرنامج بسهولة استخدامه و سهولة التعديل به. - من أكثر البرامج تميزا في حساب الإشعاعات الشمسية. - يقوم بحساب درجة الحرارة الإشعاعية المتوسطة (MRT) . - يقيم الراحة الحرارية باستخدام مؤشرات*PMV,SET*,PT,UTCI.
SOLWEIG	- برنامج مجاني . - يصعب تعديل المدخلات . - يمكن إضافة عناصر التشجير. - يمكن قياس sky view factor و درجة الحرارة الإشعاعية المتوسطة (MRT) .
ENVI-met	- يوجد منه نسخة مجانية و نسخة غير مجانية . - من مميزاته تنفيذ بيانات نباتية ثلاثية الأبعاد تسمح بتعريف الأشجار بشكل أكثر تفصيلا . - يمكن قياس درجة الحرارة الإشعاعية المتوسطة MRT . - يقيم الراحة الحرارية باستخدام مؤشرات*PMV/PPD,SET*,UTCI.

بعد مقارنة برامج المحاكاة الثلاث التي تمت دراستها، وجد أن ENVI-met4 أكثر البرامج تعاملًا مع العنصر الأخضر وتأثيره على الخواص المناخية من (رياح- ودرجة الحرارة -والرطوبة-....)، فهو يأخذ في الاعتبار البخر والنتج والإظلال (Helge et el, 2018) ، كما أنه يحتوي على مكتبة فيها العديد من العناصر الخضراء المختلفة من أشجار بارتفاعات مختلفة ، وكثافات مختلفة ، ومنها : المتساقطة ، ومنها غير المتساقطة وأيضًا شجيرات وأغطية أرضية بأشكال مختلفة. كما

أستخدام برنامج ENVI-met لمحاكاة السلوك المناخي للعنصر الأخضر داخل الفراغات العمرانية

يمكن قياس كل من درجة الحرارة الإشعاعية المتوسطة و مؤشر معدل التصويت المتوقع و الذي يستخدم في تقييم الراحة الحرارية وهذا ما سيخدم الهدف الأساسي من البحث. كما تم إستخدام البرنامج في العديد من الأبحاث العمرانية ذات صلة بموضوع البحث .

3- استخدام برنامج ENVI- met لمحاكاة السلوك المناخي للعنصر الأخضر في الفراغات العمرانية :

- يتضمن الإصدار الجديد من برنامج ENVI-met4 تنسيقاً ثلاثي الأبعاد يسمح للمستخدمين بتحديد الخصائص الفيزيائية لكل عنصر من عناصر الفراغ العمراني على حدة؛ مثلاً: (واجهات المباني - ودرجة حرارة الواجهة - والانعكاس - والامتصاص - والانبعائية - والتوصيل الحراري) ، ومن مميزاته أيضاً تنفيذ بيانات نباتية ثلاثية الأبعاد تسمح بتعريف الأشجار بشكل أكثر تفصيلاً. (Denise ,Carolina, 2016) .
- يراعي البرنامج القيام بعمل محاكاة لعمليات سطح الغطاء النباتي في الغلاف الجوي، مثل: معدل التمثيل الضوئي، يمكن تحديد نوع الشجرة المستخدمة، وتحديد ارتفاعها وقطرها؛ وبالتالي معرفة مساحة الجزء التي سوف تقوم بتظليله، كما يمكن معرفة نوع الشجرة، سواء كانت كثيفة أو متساقطة أو مثمرة ... ؛ مما يساعد المصمم على اختيار النوع المناسب من التشجير حسب الفراغ العمراني الذي يقوم بتصميمه، ولحساب ظل الشجرة على الأرض يجب تمثيل الشكل الهندسي للشجرة، ويمكن إحداث ذلك بسهولة باستخدام البرنامج (<https://www.envi-met.com>)
- من أهم خصائص برنامج ENVI-met قياس مؤشر كثافة أوراق الشجر LAD وهي إحدى خصائص الأشجار التي من خلالها يستطيع البرنامج- قياس و تقدير الأداء الحراري للأشجار (Helge et el, 2018) .
- لتحسين تمثيل النباتات في برنامج ENVI-met تم تطوير طريقة جديدة لوصف هيكل النباتات بنموذج ليندنماير (lindenmayer-system)، يسمح ذلك النموذج بوصف النباتات بطريقة أكثر واقعية، بما فيها درجة حرارة أوراق النباتات، مع مراعاة معدل التمثيل الضوئي وتوفر المياه في التربة، ومعدل النتج المحلي؛ وبالتالي تحقيق نتائج مناخية أكثر واقعية. (Helge , Tim and Michael , 2020) .

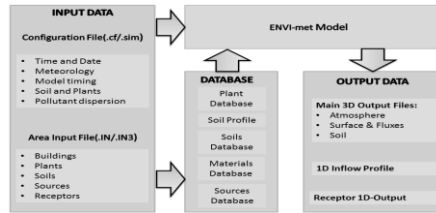

الرسم 1. نموذج يوضح مدخلات و مخرجات برنامج ENVI-met (Aida et el, 2014).

4. دراسة تحليلية على فراغ عمراني داخل كل من الجامعة الأمريكية بالقاهرة وجامعة الأميرة نورة بالرياض واستخدام برنامج ENVI-met لتحليل السلوك المناخي بهما :

1-4 الهدف من هذه الدراسة

تحديد النسبة الأكثر كفاءة لاستخدام العنصر الأخضر داخل كل من: (فراغ الجامعة الأمريكية بالقاهرة الجديدة - وجامعة الأميرة نورة بالرياض) من هذه النسب (30% - 50% - 80%)، وقد تم

تحديد هذه النسبة بناءً على دراسة سابقة (شيماء-2016) وفيها تم تحديد نسبة 25% عنصراً أخضر هي النسبة الأكثر كفاءة، وتمت هذه الدراسة باستخدام برنامج ENVI-met أيضاً وتم تحديد ذلك بعد القيام بعدد من المحاكات لنسب عنصر أخضر (25%-50%-75%-100%)؛ وبناءً على هذه النتيجة تم تحديد هذه النسب للعنصر الأخضر (30% - 50% - 80%) لهذا البحث والقيام بالعديد من المحاكات لكل من هذه النسب باستخدام برنامج ENVI-met لتحديد النسبة الأكثر كفاءة لاستخدام العنصر الأخضر لكل من الفراغين محل الدراسة، والربط بين هذه النسبة وبين نسبة الطول للعرض للفراغ العمراني، ويتم توضيح ذلك بالتفصيل في نتائج البحث.

تم القيام بعملية المحاكاة يوم 2017/6/22؛ وقد تم اختيار هذا اليوم بناءً على أنه من الأيام الأكثر ارتفاعاً لدرجة الحرارة، ثم تم أخذ القياسات للمحاكاة، وأخذ النتائج من الساعة 8 صباحاً و10 صباحاً و12 ظهراً و2 مساءً، وتم اختيار الساعة 2 مساءً لعمل المقارنة بين الوضع الحالي ومقترحات الباحث؛ وذلك نظراً لما أظهرته النتائج أن الساعة 2 مساءً هي أكثر ارتفاعاً في درجات الحرارة الإشعاعية المتوسطة في كل من الفراغين (شكل رقم 2) و(شكل رقم 3) وقد تم تثبيت بعض العناصر الأخرى الخاصة بمناطق الدراسة؛ وهي (ارتفاع المباني - نوع الأرضيات - أنواع الأشجار والنخيل الموجودة والقائمة بمنطقة الفراغ العمراني المختارة - أنواع المواد المستخدمة في واجهات المباني-).

2-4 حالات الدراسة

سبب اختيار مشروع الجامعة الأمريكية بالقاهرة الجديدة : تدعم الجامعة أهمية خلق بيئة مستدامة داخل الحرم الجامعي وكان هذا من أهم أسباب اختيارها كدراسة تطبيقية .

سبب اختيار مشروع جامعة الأميرة نوره بالرياض: تعتبر جامعة الأميرة نورة بنت عبد الرحمن مؤسسة التعليم العالي الأولى الخضراء الحاصلة علي تصنيف LEED في العالم .

3-4 معايير اختيار العينات:

لقد تم اختيار هذين الفراغين في كل من: الجامعة الأمريكية بالقاهرة وجامعة الأميرة نورة بالرياض؛ وذلك لأنهما يمثلان الساحة الرئيسية لكل من الجامعتين، واللذان يتم فيهما العديد من الأنشطة الخاصة بالطلاب.

4-4 المؤشرات الحرارية المستخدمة للقياس في الفراغات محل الدراسة

تم أخذ قياس كل من درجة الحرارة الإشعاعية المتوسط (MRT) Mean Radiant temperature و هي المعبر الرئيسي عن تأثير الإشعاع علي جسم الإنسان .

و أيضاً تم أخذ قياس معدل التصويت المتوقع (PMV) Predict Mean Vote :

وقد تم استخدامه في تقييم الراحة الحرارية للفراغات الداخلية وذلك عند حالات من الأنشطة التي يقوم بها الإنسان و أيضاً عند معدلات عزل مختلفة للملابس . و في 1970 تم عمل تعديل علي هذا المؤشر ليصبح أكثر ملاءمة للظروف المناخية في الفراغات المفتوحة بحيث تضمن جميع الإشعاعات في الفراغ العمراني مثل درجة حرارة الهواء و الرطوبة و سرعة الهواء النسبية و مستوي النشاط و الملابس و و يمكن قياسية و تحديد هذه المعاملات بسهولة عن طريق برنامج ENVI-met والحصول علي نتائج باستخدام النسخة المجانية من البرنامج .

أستخدام برنامج ENVI-met لمحاكاة السلوك المناخي للعنصر الأخضر داخل الفراغات العمرانية

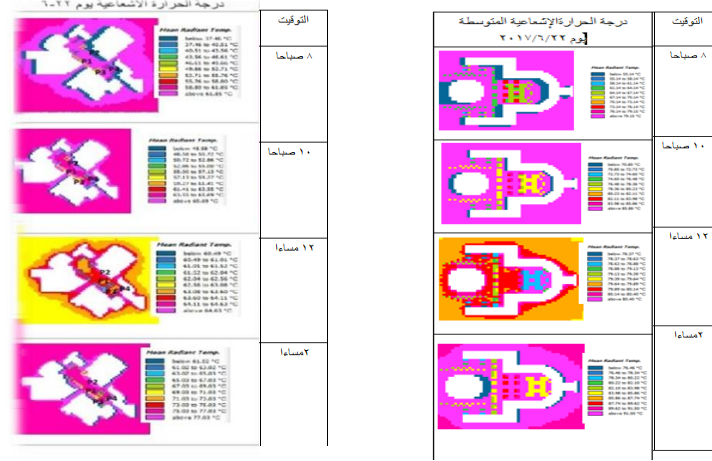

الرسم 2. درجة الحرارة الإشعاعية المتوسطة للفراغين محل الدراسة يوم 6-22 الساعة 2 مساءً .

5-4 محاكاة السلوك المناخي للفراغ العمراني بالجامعة الأمريكية بالقاهرة و جامعة الأميرة نوره بالرياض باستخدام برنامج ENVI-met 4		
جامعة الأميرة نوره بالرياض	الجامعة الأمريكية بالقاهرة الجديدة	
<p>قد شكلت الاستدامة الجانب الأساسي في عملية التصميم؛ وذلك كي يتطابق التصميم مع مبادئ الاستدامة، وذلك من خلال تطبيق استراتيجيات تتواءم مع المناخ المسيطر في الموقع والحفاظ على الطاقة ومتطلبات البيئة المستقبلية. (شكل-4)</p>  <p>شكل -4: استوحى التصميم من العمارة الإسلامية . (http://www.pnu.edu.sa)</p>	<p>تم تصميم المساحة الكلية على ساحة داخلية بأحجام مختلفة، لتخترن الهواء البارد أثناء الليل. وتم تصميم الأفنية الداخلية في سلسلة من المساحات المتتالية المتصلة مع عناصر تنسيق الموقع الطبيعية التي تضمن تدفق الهواء البارد باستمرار من الخارج للداخل (Abdelhalim, 2016)، (شكل- 3).</p>  <p>شكل -3: شكل يوضح تدفق حركة الهواء www. Crja.com / projects</p>	<p>4-5-1- الدراسة التوصيفية لمنطقة الدراسة</p>

<p>- وظيفة الفراغ: فراغ رئيسي في الجامعة يستخدم من قبل طالبات الجامعة للجلوس والاستمتاع به. (شكل-6) .</p> <p>- الغطاء النباتي : مستوى الغطاء: متوسط الارتفاع (شجيرات)، عالي الارتفاع (نخيل) خصائصه: دائم الخضرة - يصلح للمنظر العام، موطنه: محلي.</p> <p>- الخصائص المناخية للموقع: يسود المنطقة مناخ صحراوي قاري، يتميز بالحرارة والجفاف في فصل الصيف، الممتد من يونيو حتى سبتمبر لتصل إلى متوسط 43 درجة مئوية، وتنخفض درجة البرودة في فصل الشتاء الممتد من ديسمبر حتى فبراير إلى 10 درجات مئوية .</p>  <p>شكل-6 : الفراغ العمراني محل الدراسة . (http://www.pnu.edu.sa)</p>	<p>- وظيفة الفراغ: فراغ رئيسي في الجامعة يقام به العديد من النشاطات الخاصة بطلاب الجامعة. (شكل -5)</p> <p>- الغطاء النباتي : مستوى الغطاء: متوسط الارتفاع (أشجار)، عالي الارتفاع (نخيل) ، خصائصه: دائم الخضرة - يصلح للمنظر العام - موطنه: محلي .</p> <p>- الخصائص المناخية للموقع: مناخ القاهرة الجديدة صحراوي، ونظرًا لارتفاعها، تتمتع القاهرة الجديدة بجو أطف من القاهرة وهي تقل عنها بخمس درجات مئوية تقريبًا.</p>  <p>شكل-5 : الفراغ العمراني محل الدراسة (www.aucegypt.com /)</p>	<p>2-5-4- وصف الفراغ محل الدراسة</p>
<pre> #---- ENV1-met V4 main configuration file ----- #---- generated with ProjectWizard ----- FileVersion =4.3 JobID =Simulation % Main data Name for Simulation (Text): =Simulation pnu-9-01-018 Area Input File to be used =NewArea.INX Filebase name for Output (Text): =NewSimulation Output Directory: = Start Simulation at Day (DD.MM.YYYY): =22.06.2017 Start Simulation at Time (HH:MM:SS): =06:00:00 Total Simulation Time in Hours: =12 Wind Speed in 10 m ab. Ground [m/s]: =3.5 Wind Direction (0=N, 90=E, 180=S, 270=W,..) =0 Roughness Length z0 at Reference Point [m] =0.01 Initial Temperature Atmosphere [K] =316.150 Specific Humidity in 2500 m [g Water/kg air] =5.3 Relative Humidity in 2m [%] =11 % End main data [OUTPUTTIMING] Output interval main files (min) =60.00 Output interval text output files (min) =30.00 Include Nesting Grids in Output (0=m,1=y) =0 [FINISH] Update Surface Data each 7 sec =30.00 Update Wind field each 7 sec =900.00 Update Radiation and Shadows each 7 sec =600.00 Update Plant Data each 7 sec =600.00 [PARALLEL CPU] </pre> <p>شكل 8: مدخلات البرنامج يوم 22-6 الخاصة بمدينة الرياض .</p>	<pre> #---- ENV1-met V4 main configuration file ----- #---- generated with ProjectWizard ----- FileVersion =4.3 JobID =Simulation % Main data Name for Simulation (Text): =Simulation aue-existing Area Input File to be used =NewArea.INX Filebase name for Output (Text): =NewSimulation Output Directory: = Start Simulation at Day (DD.MM.YYYY): =22.06.2017 Start Simulation at Time (HH:MM:SS): =06:00:00 Total Simulation Time in Hours: =12 Wind Speed in 10 m ab. Ground [m/s]: =3.5 Wind Direction (0=N, 90=E, 180=S, 270=W,..) =0 Roughness Length z0 at Reference Point [m] =0.01 Initial Temperature Atmosphere [K] =309.000 Specific Humidity in 2500 m [g Water/kg air] =4.6 Relative Humidity in 2m [%] =60 % End main data [OUTPUTTIMING] Output interval main files (min) =60.00 Output interval text output files (min) =30.00 Include Nesting Grids in Output (0=m,1=y) =0 [PARALLEL CPU] CPU usage settings =ALL </pre> <p>شكل 7: مدخلات البرنامج يوم 22-6 الخاصة بمدينة القاهرة الجديدة .</p>	<p>3-5-4- تم إدخال المحددات المناخية الخاصة بيوم 22-6 بالاستعانة بـ weather file (شكل 7-) و (شكل 8-) .</p>

أستخدام برنامج ENVI-met لمحاكاة السلوك المناخي للعنصر الأخضر داخل الفراغات العمرانية

 <p>شكل 10: نقط القياس لفراغ جامعة الأميرة نوره بالرياض .</p>	 <p>شكل 9: نقط القياس لفراغ الجامعة الأمريكية بالقاهرة</p>	<p>4-5-4- تم تحديد 4 نقاط أساسية في كل من الفراغيين لتحديد تأثير السلوك المناخي بها، وهي P1 - P2 - P3 - P4 (شكل- 9) و (شكل- 10)</p>
 <p>شكل 12: مخرجات ENVI-met لدرجة الحرارة الإشعاعية المتوسطة.</p>	 <p>شكل 11: مخرجات ENVI-met لدرجة الحرارة الإشعاعية المتوسطة.</p>	<p>4-5-5- قياسات درجة الحرارة الإشعاعية المتوسطة (MRT). للوضع القائم للفراغ محل الدراسة (شكل- 11) و(شكل- 12)</p>
<p>تصميم هذا الفراغ يعاني من بعض القصور في الجزء المتعلق بمراعاة التصميم بالعنصر الأخضر؛ فالأشجار المستخدمة ارتفاعها لا تعطي مساحة ظل كافية بجانب عدم كثافة تيجانها، استخدام نادر للنجيلة في الأرضيات يكاد يكون منعدماً؛ مما أدى إلى تأثير ذلك على المناخ المحيط بالفراغ، وذلك ما تم إثباته عن طريق تحليل السلوك المناخي للفراغ باستخدام برنامج المحاكاة ENVI-met</p>	<p>تصميم هذا الفراغ يعاني من بعض القصور وخاصة في الجزء المتعلق باستخدام العنصر الأخضر في الفراغ، فنسبة التشجير قليلة جداً؛ مما أدى إلى ضعف تأثيرها في الفراغ محل الدراسة، وذلك ما تم إثباته عن طريق تحليل السلوك المناخي للفراغ باستخدام برنامج المحاكاة ENVI-met .</p>	<p>4-5-6- نتائج تحليل الوضع القائم لكل من الفراغيين محل الدراسة:</p>
<p>- استخدام الأشجار العمودية كحواجز حمايه ضد العواصف الرملية. - استبدال الحصى بالحشائش فهي تعمل على امتصاص الحرارة ومنع إثارة الأتربة والشعور بالراحة والهدوء النفسي. - استخدام غطاء شجري ذي كثافة عالية فهي تساعد على رفع نسبة الرطوبة. - استخدام أكبر الأشجار ذات الشكل البيضاوي فيمكن استعمالها لتوفير الظل</p>	<p>- استخدام أشجار كثيفة، فكلما زادت كثافة الأشجار أدى ذلك إلى أن تكون أقل نفاذية ومسامية وتعمل على حجب أشعه الشمس بنسبه 98%. - نوصي باستخدام نسبة أكثر من الحشائش حيث تعمل الحشائش على تقليل درجة الحرارة من 10 إلى 14 درجة من سطح الأرض . - استخدام أشجار ذات أوراق إبرية فهي تخلق ظلًا متناثرًا على نطاق</p>	<p>4-5-7- المقترحات</p>

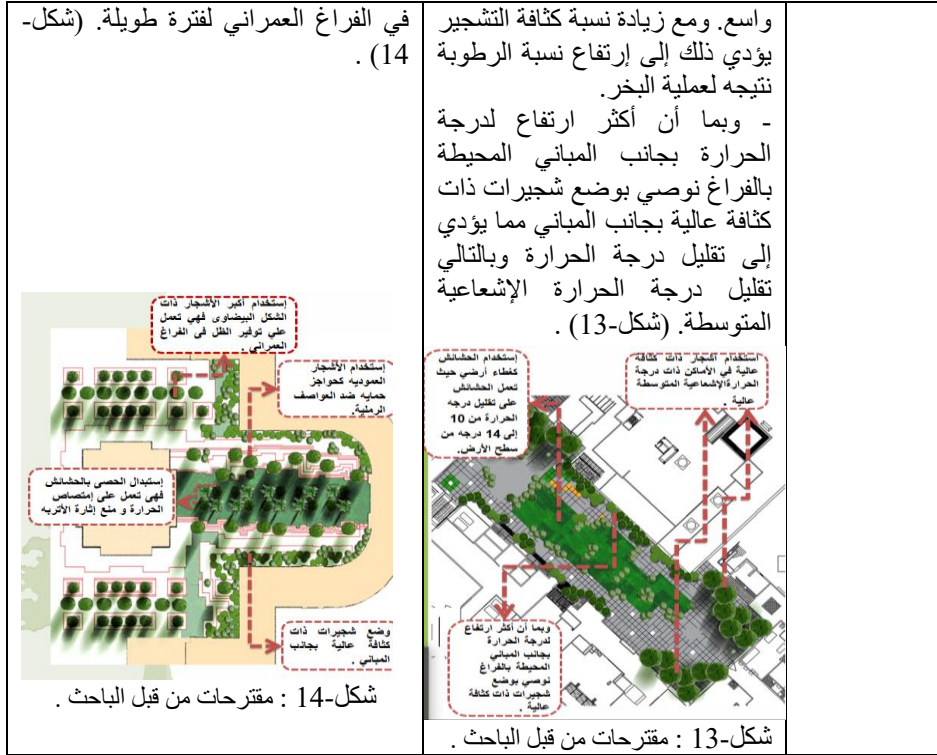

6-4 دراسة تأثير اختلاف نسب العنصر الأخضر على السلوك المناخي في منطقة الدراسة الأولى (فراغ الجامعة الأمريكية بالقاهرة الجديدة) .

يتأثر السلوك المناخي للفراغات العمرانية باختلاف نسبة وجود العنصر الأخضر بها، لذا في هذا الجزء من البحث سوف نحلل السلوك المناخي باستخدام برنامج ENVI-met4 لثلاثة نسب مختلفة للعنصر الأخضر 30%، 50%، 80% فراغ الجامعة الأمريكية بالقاهرة الجديدة واستنتاج النسبة الأكفاء لكل فراغ. ولقد تم إختيار العناصر الخضراء جميعها محلية لتحقيق العامل الاقتصادي و أيضا بناء علي الأقتراحات في الفقرة السابقة من البحث من (ارتفاع - كثافة - حجم) .

لقد تم مراعاة توزيع العنصر الأخضر بصورة تراعي العناصر المناخية الخاصة بالفراغ، والتي تمت دراستها وتحليلها بعد إجراء عملية المحاكاة للوضع القائم وبناءً علي المقترحات التي تم توضيحها من قبل الباحث في النقطة السابقة من البحث، وسوف يتم أخذ النتائج يوم 6/22 الساعة 2 مساءً بناءً علي الأسباب التي . ولقد تم اختيار العناصر الخضراء جميعها محلية لتحقيق العامل الاقتصادي .

أستخدام برنامج ENVI-met لمحاكاة السلوك المناخي للعنصر الأخضر داخل الفراغات العمرانية

جدول 2- : تأثير تغيير نسب العنصر الأخضر داخل فراغ الجامعة الأمريكية بالقاهرة .

فراغ الجامعة الأمريكية (80%)	فراغ الجامعة الأمريكية (50%)	فراغ الجامعة الأمريكية (30%)	فراغ الجامعة الأمريكية الوضع القائم	المساح الألفي المقترح
				مجموع ثلاث الأبعاد
				المساح الألفي داخل برنامج ENVI-met4
				درجة الحرارة الإشعاعية المتوسطة (mrt)
				معدل التصويت المتوقع (pmv)

4-6-1- تأثير تغيير نسب العنصر الأخضر على كل من درجة الحرارة الإشعاعية المتوسطة (mrt) والراحة الحرارية (pmv) داخل فراغ الجامعة الأمريكية بالقاهرة .

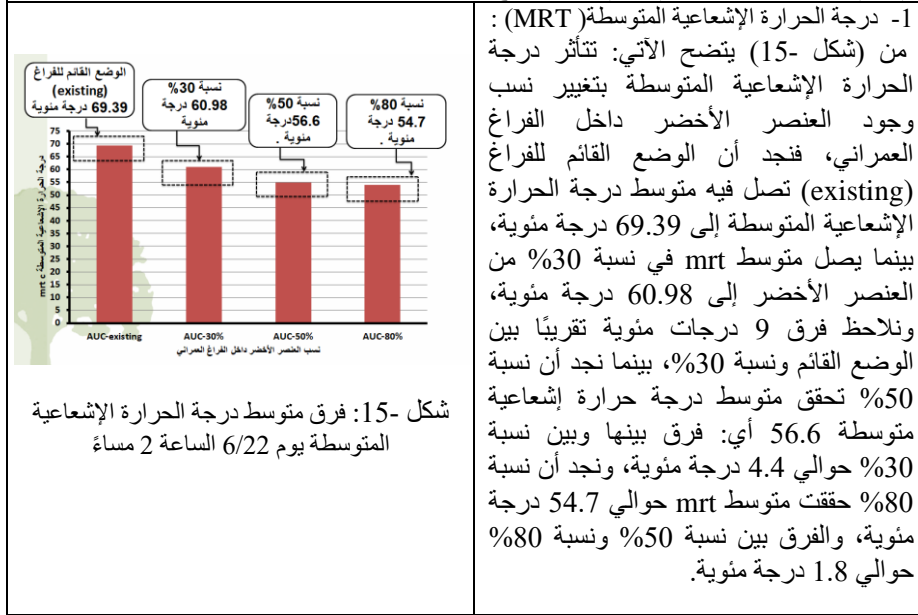

1- درجة الحرارة الإشعاعية المتوسطة (MRT) : من (شكل 15) يتضح الآتي: تتأثر درجة الحرارة الإشعاعية المتوسطة بتغيير نسب وجود العنصر الأخضر داخل الفراغ العمراني، فنجد أن الوضع القائم للفراغ (existing) تصل فيه متوسط درجة الحرارة الإشعاعية المتوسطة إلى 69.39 درجة مئوية، بينما يصل متوسط mrt في نسبة 30% من العنصر الأخضر إلى 60.98 درجة مئوية، ونلاحظ فرق 9 درجات مئوية تقريباً بين الوضع القائم ونسبة 30%، بينما نجد أن نسبة 50% تحقق متوسط درجة حرارة إشعاعية متوسطة 56.6 أي: فرق بينها وبين نسبة 30% حوالي 4.4 درجة مئوية، ونجد أن نسبة 80% حققت متوسط mrt حوالي 54.7 درجة مئوية، والفرق بين نسبة 50% ونسبة 80% حوالي 1.8 درجة مئوية.



أستخدام برنامج ENVI-met لمحاكاة السلوك المناخي للعنصر الأخضر داخل الفراغات العمرانية

7-4دراسة تأثير اختلاف نسب العنصر الأخضر على السلوك المناخي في منطقة الدراسة الثانية (فراغ جامعة الأميرة نوره بالرياض) .

تحليل السلوك المناخي باستخدام برنامج ENVI-met4 لثلاثة نسب مختلفة للعنصر الأخضر 30%، 50%، 80% ، وسوف يتم أخذ النتائج يوم 6/22 الساعة 2 مساءً. ولقد تم إختيار العناصر الخضراء جميعها محلية لتحقيق العامل الاقتصادي و ايضا بناءا علي الاقتراحات في الفقرة السابقة من البحث من (ارتفاع - كثافة - حجم) . (جدول -3) .

جدول -3: نسب العنصر الأخضر المختلفة في فراغ جامعة الأميرة نورة بالرياض.

فراغ جامعة الأميرة نورة الوضع القائم	فراغ جامعة الأميرة نورة (30%)	فراغ جامعة الأميرة نورة (50%)	فراغ جامعة الأميرة نورة (80%)
المسقط الأفقي المقترح			
مقسم ثلاثي الأبعاد			
المسقط الأفقي داخل برنامج ENVI-met4			
درجة الحرارة الإشعاعية المتوسطة (mrt)			
معدل التبريد التبريد (pmv)			

7-4-1- تأثير تغيير نسب العنصر الأخضر على كل من درجة الحرارة الإشعاعية المتوسطة (mrt) والراحة الحرارية (pmv) داخل فراغ جامعة الأميرة نوره بالرياض .

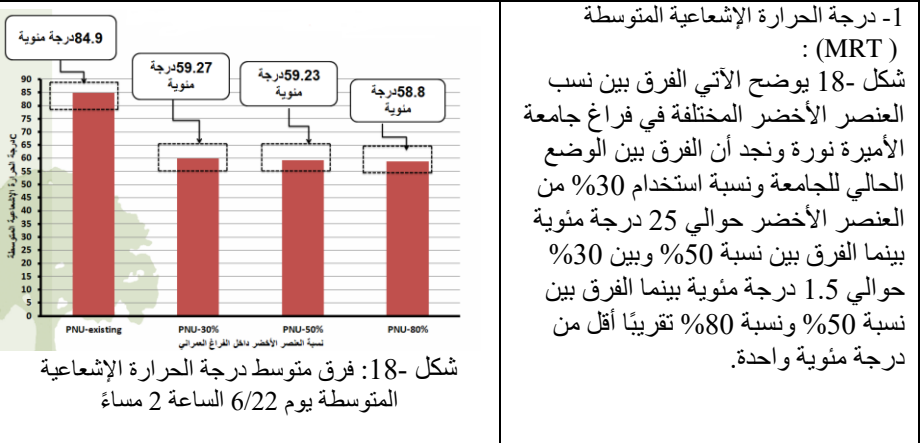



أستخدام برنامج ENVI-met لمحاكاة السلوك المناخي للعنصر الأخضر داخل الفراغات العمرانية

النتائج :

- برنامج ENVI-met من أفضل برامج محاكاة السلوك المناخي في تحديد مدى تأثير عناصر التشجير علي السلوك المناخي للفراغات العمرانية .
 - رغم أن نسبة 80% لوجود العنصر الأخضر أكثر من 50% إلا أنه لا يوجد فرق كبير في درجة الحرارة الإشعاعية المتوسطة حوالي درجة واحدة، وأيضاً في قياس الراحة الحرارية الفرق قليل جداً في فراغ الجامعة الأمريكية بالقاهرة، بينما الفرق بين نسبة 30% ونسبة 50% في جامعة الأميرة نورة بالرياض فرق درجة ونصف؛ ومن هنا نجد أن يكون من الأنسب استخدام النسبة الأقل من العنصر الأخضر من الناحية الاقتصادية، وكذلك توفيراً لتكلفة الصيانة والتشغيل.
- بعد دراسة فرق استخدام نسب العنصر الأخضر المختلفة 30%، 50%، 80% وجدنا الآتي:
- نسبة 1:3 بين ضلعي الفراغ العمراني في حالة الجامعة الأمريكية بالقاهرة الجديدة تحتاج إلى 50% من العنصر الأخضر لتحقيق أقرب راحة حرارية بها، بينما نسبة 1:1.5 في حالة جامعة الأميرة نورة بالرياض تحتاج نسبة 30% من العنصر الأخضر لتحقيق أقرب راحة حرارية لها باستخدام العنصر الأخضر، وبناءً علي دراسة سابقة (شيماء -2016) نسبة 1:1 تحتاج 25% من العنصر الأخضر لتحقيق أقرب راحة حرارية في الفراغ العمراني و ذلك ما تم إثباته بالإستعنه ببرنامج4 ENVI-met . (جدول- 4) .

جدول-4 : النسبة بين الطول للعرض في الفراغ العمراني واستخدام العنصر الأخضر بها.

نسبة العنصر الأخضر في الفراغ	نسبة الطول للعرض للفراغ العمراني	رسم توضيحي
50%	1:3	
30%	1:1.5	
25%	1:1	

التوصيات :

- يجب علي المصمم العمراني الأهتمام بشكل أكبر باستخدام برامج محاكاة السلوك المناخي .
- على المصمم العمراني اختيار المكان المناسب لكل عنصر نباتي في الفراغ العمراني، واختيار موقعها بشكل صحيح؛ مما قد يضمن تحقيقها في تحسين السلوك المناخي للفراغات.
- مراعاة إستخدام عناصر خضراء من نفس البيئة الخاصة بكل فراغ و ذلك مراعاة للظروف الاقتصادية من نقل و ايضاً تكاليف الصيانة .

الشكر

يخص الكاتب بالشكر كلا من أ.د أحمد فكرى و د.ريهام الدسوقي لما قدموه من دعم و إضافة علمية.

المراجع

- Bruse, M., August 2020, ENVI-Met Documentation.: Available online: <http://www.envi-met.net/documents/papers/overview30.pdf> .
- Carolina S. Gussona , Denise H. S. Duarte, 2016, Effects of Built Density and Urban Morphology on Urban Microclimate - Calibration of the Model ENVI-met V4 for the Subtropical Sao Paulo, Brazil - *4th International Conference on Countermeasures to Urban Heat Island (UHI)* - a Department of Technology, Faculty of Architecture and Urbanism, University of Sao Paulo- p.5-6.
- Abdelhalim, I. , 2016, Narratives of the built and un built of AUC, new campus, *community design collaborative*, P.15.
- Aida Maleki, Kristina Kiesel, Milena Vuckovic, and Ardeshir Mahdavi , 2014, Empirical and Computational Issues of Microclimate Simulation, Department of Building Physics and Building Ecology, Vienna University of Technology, Vienna, Austria , *FIP International Federation for Information Processing* .
- Helge Simon * , Tim Sinsel and Michael Bruse , 2020, Introduction of Fractal-Based Tree Digitalization and Accurate In-Canopy Radiation Transfer Modelling to the Microclimate Model ENVI-Met , Department of Geography, *Johannes Gutenberg University Mainz, 55099 Mainz, Germany* .
- Helge Simona,* , Jenny Lindénb, David Hoffmannc, Peter Braund, Michael Brusea ,2018 Modeling transpiration and leaf temperature of urban trees – A case study evaluating the microclimate model ENVI-met against measurement data , Jan Espera a Department of Geography, Johannes Gutenberg University Mainz, *Swedish Environmental Research Institute, Air Pollution & Abatement Strategies* , Sweden School of Earth, Atmosphere and Environment, Monash University, Australia Department of Pomology, Geisenheim University, Germany.
- Yung-Chang Chen , Tzu Ping Lin and Andreas Matzarakis ,2014, Comparison of mean radiant temperature from field experiment and modelling: a case study in Freiburg, Germany , *Article in Theoretical and Applied Climatology* .
- Dalong Liu , Xiaowei Jia , and Wenqin Wang , 2019 ,Comparative analysis of simulation of urban radiation field , *MATEC Web of Conferences 282 CESBP* .
- شيماء سعد الدين ، (2016) ،تأثير مكونات الفراغ العمراني علي الراحة الحرارية في الفراغات العمرانية , ماجستير ، جامعة القاهرة ، كلية الهندسة.
- [/https://www.envi-met.com](https://www.envi-met.com)
www.aucegypt.com
[www. Crja.com / projects](http://www.Crja.com/projects)
<https://www.meteoblue.com/ar/weather/forecast/modelclimate>

REDEFINITION OF HERITAGE PUBLIC SPACES USING PPGIS

The Case of Religious complex in Old Cairo

AYA ELGOBASHI, YASMEEN EL SEMARY

*Arab Academy for Science, Technology and Maritime Transport,
Egypt*

Email address: aya_elgobashi@hotmail.com

Email address: ysemary@gmail.com

Abstract. Plenty of challenges all over the world are affecting the urban development of spaces in the cities, especially those of heritage sites; these urban spaces provide various ambiances that appeal to the senses. Although surrounded open spaces in heritage sites are full of rich, deep knowledge that plays an active role in the community perceptions, it has been recently neglected. A contribution is paid to the combination of digital technologies to help in preserving those spaces. Its integrated use could exponentially increase the effectiveness of conservation strategies of ancient buildings. GIS technology became a usual documentation tool for heritage managers, conservators, restorers, architects, archaeologists, painters, and all other categories of experts involved in cultural heritage activities. Consequently, the GIS has faced strong criticism as it is a tool for documentation without engaging in the public environment and the users' needs; as a result, GIS cannot help in any enhancing process as it does not have any idea about the needs of the users. This paper analyses public uses efficiency in heritage public spaces in Cairene context using public participation geographic information system (PPGIS) methodology, as it gives attention to the term "user" to include the "public" incorporating the concept of "public participation" commonly used in planning. An online survey was set up, based on Google Maps, where respondents were asked to place and rate twenty-five items on an interactive map done by (ARCGIS 10.4). These items were based on the criteria of placemaking to make those spaces full of creative ambiance to be more attractive and useful to the communities. Finally, 200 valid surveys have been collected and mapped 1500 opinions have been mapped. The Results of this research show that PPGIS is an effective tool in measuring the efficiency of those heritage public spaces, which may be valuable for future planning.

Keywords: *Public spaces, Heritage Sites, cultural heritage PPGIS, Preserving, Digital heritage.*

ملخص. تؤثر الكثير من التحديات في جميع أنحاء العالم على التطور العمراني للمساحات في المدن ، ولا سيما مواقع التراث ؛ توفر هذه المساحات الحضرية أجواء مختلفة تروق للحواس. على الرغم من أن المساحات المفتوحة المحاطة في المواقع التراثية مليئة بالمعرفة الغنية والعميقة التي تلعب دورًا نشطًا في تصورات المجتمع ، فقد تم إهمالها مؤخرًا. يتم تقديم مساهمة في الجمع بين التقنيات الرقمية للمساعدة في الحفاظ على تلك المساحات. يمكن أن يؤدي استخدامه المتكامل إلى زيادة فعالية استراتيجيات الحفاظ على المباني القديمة بشكل كبير. أصبحت تقنية نظم المعلومات الجغرافية (GIS) أداة توثيق معتادة لمديري التراث ، والقائمين بترميمه ، والترميم ، والمهندسين المعماريين ، وعلماء الآثار ، والرسامين ، وجميع فئات الخبراء الأخرى المشاركة في أنشطة التراث الثقافي. ونتيجة لذلك ، واجه نظام المعلومات الجغرافية انتقادات شديدة لأنه أداة للتوثيق دون الانخراط في البيئة العامة واحتياجات المستخدمين ؛ نتيجة لذلك ، لا يمكن لنظام المعلومات الجغرافية أن يساعد في أي عملية تعزيز لأنه ليس لديه أي فكرة عن احتياجات المستخدمين. تحلل هذه الورقة كفاءة الاستخدامات العامة في الأماكن العامة التراثية في سياق القاهرة التاريخية باستخدام منهجية نظام المعلومات الجغرافية للمشاركة العامة (PPGIS) ، حيث إنها تولى اهتمامًا لمصطلح "المستخدم" ليشمل "الجمهور" الذي يدمج مفهوم "المشاركة العامة" الشائع الاستخدام في التخطيط. كان استطلاع عبر الإنترنت يعتمد على خرائط Google القائمة على الإعداد ، وقد طلب من المستخدمين وضع وتقييم خمسة وعشرين عنصرًا على خريطة تفاعلية تم إجراؤها بواسطة (ARCGIS 10.4). تستند هذه العناصر إلى معايير صناعة الأماكن لجعل تلك المساحات مليئة بالأجواء الإبداعية لتكون أكثر جاذبية وفائدة للمجتمعات. أخيرًا ، تم جمع 200 استبيان صالح وتعيين 1500 رأي على الخريطة. تظهر نتائج هذا البحث أن PPGIS هي أداة فعالة في قياس كفاءة تلك الأماكن العامة التراثية والتي قد تكون ذات قيمة للتخطيط المستقبلي.

الكلمات المفتاحية: *الأماكن العامة ، مواقع التراث ، التراث الثقافي PPGIS ، الحفاظ ، التراث الرقمي.*

1. Introduction

Within the previous years, the rapid and massive process of developing countries took place. This massive process is called urbanization. This phenomenon is not a new or modern one, but it became clearer due to the rapid change. These changes challenge a lot of issues to achieve resiliency, inclusiveness, sustainability and enhancement of the quality of urban life (Saadallah, 2020). Quality of urban spaces can be enhanced in different ways. This research will focus on heritage public spaces. Before the pandemic, those spaces were neglected in a lot of countries especially in Careine context. These heritage public spaces contain a significant part of the cultural heritage (Giannopoulou et al., 2014). Cultural heritage is important for its generation and future generations in order to know their original form or that which has been kept so far (Petronela et al., 2016). The historic urban landscape has been preserved in the historic centre of the European centre and it was a very successful model. Old towns with surrounding landscapes are being restored and it is attempted to incorporate them into the contemporary urban functions, by recognizing their

REDEFINITION OF HERITAGE PUBLIC SPACES USING PPGIS: THE CASE OF RELIGIOUS COMPLEX IN OLD CAIRO

importance(Giannopoulou et al., 2014). The main key for protecting the historical sites or areas is to know all the relevant information. This information should be collected and mapped in a database to be easily accessed by each of the researcher, the architect, and the urbanist while enhancing the processes.

Traditional research methods are not able to successfully meet the need of collecting, elaborating, and analysing mass data (Rui, 2008). As a result and in order to have more accurate georeferenced information from non-expert users and a reference procedure, public participation geographic information system (PPGIS) is used to engage the public participation visitor with those heritage public spaces(Brown and Fagerholm, 2015). Public participation geographic information system (PPGIS) naturally enables a wide range of events to be placed into coordinates and mapped using the ArcGIS (palacio buendía et al., 2019). In this paper, we analyse public use of heritage public spaces using public participation geographic information system (PPGIS). The main aim of the paper is to determine how and where users use the most spaces and know their opinions on them. In our study we choose 'The Case of Religious complex' in old Cairo. The public space in this heritage complex is unique and rare as it is home to three monotheistic religions(Elgobashi and Elsemary, 2020a).

2. Digitalisation of Cultural Heritage

The meanings of the past are conceptualized as "heritage attached to the present," or as "socially established awareness, including material, as well as intangible, political, and cultural backgrounds." (Silverman, 2011). It has been defined that digitalisation of cultural heritage is a comprehensive procedure of cultural heritage management in a digital setting(Ognjanović et al., 2019). It also been used in the long-term preservation, presentation, and provision of accessibility to the contents (Ognjanović et al., 2019).

During the 21st century, preservation technologies were used while preserving or enhancing any heritage space to make its cultural heritage more efficient and effective (Nikonova and Biryukova, 2017). Culture heritage is local culture and identity of urban spaces with a lot of meaning. The built environment and the culture are relatively close together(Meddan, 2012). While studying the relation between design of the built environment and the culture, there was a reflection of this relation on the public spaces(Assem and El-Sayed, 2018). The cultural heritage is an integration of several aspects such as human, social and physical activities beyond the urban elements (Abdel Tawab, 2014).

Recently, a lot of researches have been calling for enchaining the connection of heritage and planning to management with the daily life of the communities (García-Esparza and Altaba Tena, 2020). In line with recent research, historic urban cores can be enhanced by applying new policies, regulations, and criteria for preservation (García-Esparza and Altaba Tena,

2020), especially after the 2020 pandemic, where open spaces gained a lot of attention. An open space can be considered an oasis of greenery and heritage in a concrete desert(Willet, 2001). Although surrounded open space in heritage sites is full of rich, deep knowledge and plays an active role in the community, it has been neglected. Due to the rapid change and development in the urban context, a lot of this heritage public space lost environmental quality, natural resource production economic opportunity, and a sense of place(Willet, 2001). Therefore, the following section of the literature review will introduce the digital heritage idea then focus on the public participation geographic information system (PPGIS) methodology that will help in enhancing those heritage public spaces to become more attractive to the users.

2.1. DIGITAL HERITAGE DEFINITIONS AND DOMAINS

According to the UNESCO, digital heritage is referred to as any “born digital” as it contains unique resources of human knowledge “created digitally or converted into digital-form from existing analogue resources”(UNESCO, 2009). A lot of researchers defined “Digital heritage” as the integration between culture of users with Technology, and of digital knowledge with research(He et al., 2017). Nevertheless, the definition of the ‘digital heritage’ is still a huge one with no clear methods and objectives. ‘Digital heritage’ is considered a process more than merely a tool to present or communicate with end-users (Rahaman, 2018).

Under the UNESCO Charter, the main sources of intangible cultural heritage, such as e-form (electronic copies, etc.) for conventional cultural storage (e.g. electronic archives, archives, exposures, databases, etc.) and electronic format, may ultimately become an object of cultural heritage but may become artefacts of a new cultural heritage (computer programmes, webs, technologies, digital works of art etc.)(Nikonova and Biryukova, 2017). Using computers, technology helps in creating these digital resources which help to obtain a huge database to be shared over time and across spaces. This is confirmation of a digital heritage. It is a legacy in many countries with many different features and many common risks. (UNESCO, 2009).

Due to timely changes or versatile implementations of current standards, many countries have created digital preservation rules. This law helped form effective cooperation for better use of the data (Alan, 2016). Consequently, there was a development of the social, economic, and touristic aspects of any heritage space. GIS is particularly a useful tool for saving the cultural heritage to preserve in the right direction and not lose cultural heritage meaning. In addition, both researchers need to work together to overcome challenges like antiquated copyright systems, rapidly developing new technologies and the huge diversity of digital content(Alan, 2016). Generally, GIS is multi-disciplinary data which can help in evaluating and

REDEFINITION OF HERITAGE PUBLIC SPACES USING PPGIS: THE CASE OF RELIGIOUS COMPLEX IN OLD CAIRO

preserving sites with historic or cultural value (as it provides data for the researcher to do a lot of studies). It combines database with geometrical and spatial referencing (Giannopoulou et al., 2014). GIS has been around for years all over the world in large amounts by keeping cultural heritage digitality but never “fixed” in a physical form (Alan, 2016). In the 1990s, a strong criticism towards the GIS was evolved as it did not have impact on the physical life of the users (Harris et al., 2002). “While digital technologies offer a means of giving unlimited access to culture today, access tomorrow is far from guaranteed” (Alan, 2016). Finally, a lot of researchers and urbanists realized that GIS is more than just a tool for storing the data and displaying it. GIS was used for spatial analysis and mapping based on survey and public participation geographic information system (PPGIS) methodology (Palacio Buendía et al., 2019). As shown in Figure 1, In the late 1990s, tourism researchers developed the GIS tool and became interested in public participation geographic information system (PPGIS) methodology as a tool to enhance citizen participation in tourism planning and development (Stewart et al., 2008).

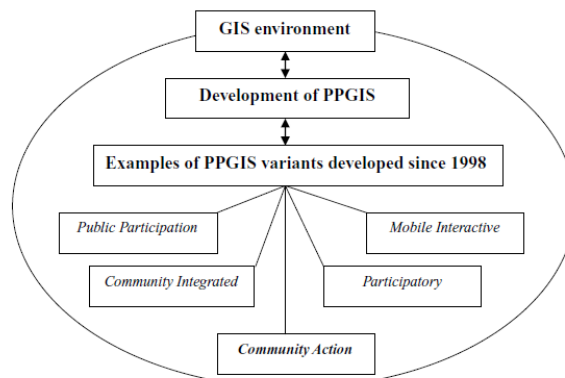

Figure 1. Relationship between GIS, PPGIS and variants of PPGIS (Stewart et al., 2008)

The following sections will focus on the public participation geographic information system (PPGIS) and how it will help in improving usability of heritage public spaces.

2.2 TOWARD SUCCESSFUL HERITAGE PUBLIC SPACES USING (PPGIS).

In 1996, public participation geographic information system (PPGIS) attracted the attention of a lot of researchers as it engaged the public in applications of GIS in improving the transparency process (Czepkiewicz and Snabb, 2013). Public participation geographic information system (PPGIS) has been recognized in many processes of decision making such as in urban planning, pollution assessment, and natural resource management (Hu et al., 2015), in addition to the public users such as stakeholders and interested

citizens who can help produce decisions that could better serve people's needs (Hu et al., 2015). Nowadays, the Public Participation Geographic Information System (PPGIS) has gained significant interest as a tool that can enable societies to create a framework for future planning. (McKinnon, 2001). The Public Participation Geographic Information System (PPGIS) is a methodology that aims to include more comprehensive ways of engaging local communities and individuals in a method called participatory mapping. (Saadallah, 2020). A lot of studies were done by a lot of researchers especially Kevin Lynch. In three separate cities Kevin Lynch examines the interpretation of consumers by drawing up maps that display major characteristics of their towns and the effects of those features of their maps of how people arrange space knowledge on their buildings (Lynch, 2005). As shown in figure 2, public participation geographic information system (PPGIS) can offer five stages for visualizing, situating, and integrating numerous stakeholders' perspectives, which can offer proposals for better heritage public spaces(Hu et al., 2015).

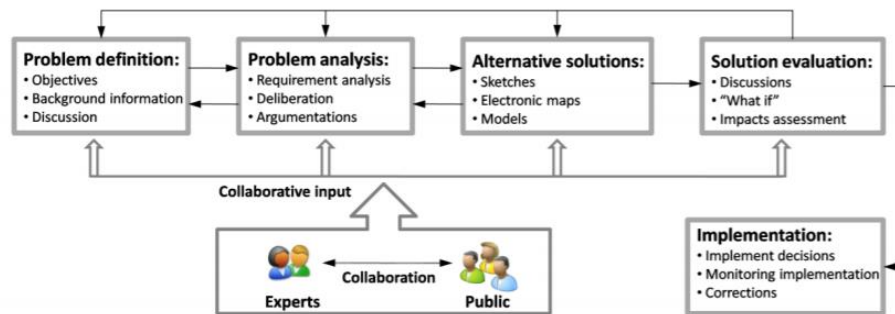

Figure 2. Five stages for visualizing, situating, and integrating numerous stakeholders' perspectives(Hu et al., 2015).

Recently, public participation geographic information system (PPGIS) has played an important role in different disciplines such as urban planning, community development, landscape ecology and those of natural resources (Sieber, 2006). Public participation geographic information system (PPGIS) approach contributes to the combination of various qualitative and quantitative research tools (Hasse, 2001). In various projects using public participation geographic information system (PPGIS), it was found that research is supported by different stages of a collaborative planning process which enhances the quality of the entered data to GIS (Steinmann et al., 2004). This planning process has been done based on a number of participants in this process. The participatory mapping has been expanded by a lot of techniques in GIS which helps GIS to create activity maps for the spaces; this is useful for the spatial context and complexity, articulation of spaces through analysing both interactivity and interconnection (Townley et al., 2009). The spatial context can be analysed in GIS through a lot of

REDEFINITION OF HERITAGE PUBLIC SPACES USING PPGIS: THE CASE OF RELIGIOUS COMPLEX IN OLD CAIRO

different queries: for example, the stakeholder, activities in space, circulations, geographic accessibility, mobility, place identity and attractive points in the spaces. The approach of public participation geographic information system (PPGIS) approach has a strong component in the heritage public spaces as it helps collect data from the community interacting with the spaces. This strong component enables and gives chances to the community to evolve in the enhancing process of the space knowing their interests and needs (Hasse, 2001). Nowadays, a lot of attention and emphasis is put toward the social and environmental sustainability especially after the 2020 pandemic, hence, the public participation geographic information system (PPGIS) approach should move beyond the conventional representations of where people live to describe more effectively the dynamics of how people live (Saadallah, 2020), nonetheless enhance the quality of life of communities.

3. (PPGIS) Evaluation Criteria Based on Placemaking

First, in this paper researchers selected and proposed the criteria to be evaluated. Second, it helps in the designed, configuration of the survey and PPGIS interface; and third, the researcher can evaluate efficiency of those heritage public spaces.



Figure 3 A successful basic public space criteria (Source : J.Gehl, S.Carr, PPS and W.H. Whyte)

Placemaking with creative ambiance principles will be the base of this study in alliance with the fact that the philosophy of placemaking is based on the fact that every human has the right to access a liveable and attractive place.

Successful places will greatly impact on their perception and social quality of life (Elgobashi and Elsemary, 2020). Placemaking was introduced as a new concept for a better belonging and sense of place in the book of Edward Relph “Place and Placelessness”: directly experienced phenomena of the lived-world and hence is full of meanings, with real objects and with ongoing activities. (Relph, 2008) This new concept was to translate physical and non-physical aspects integrated with ambiance taxonomy as shown in Figure 4. This is called creative ambiance (Elgobashi and Elsemary, 2020a).

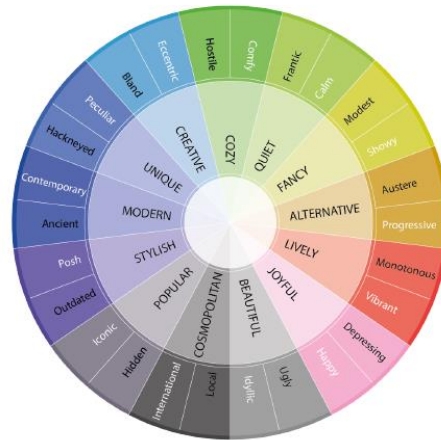

Figure 4. Ambiance taxonomy Wheel. Source:(Redi et al., 2018)

Public participation geographic information system (PPGIS) gives attention to the term “user” to include the “public” incorporating the concept of “public participation” commonly used in planning (Konomi and Roussos, 2017). Public participation geographic information system (PPGIS) method involves local communities creating information to be fed into a spatial mapping database and later used in decision making on spatial issues affecting those communities (Konomi and Roussos, 2017). To provide useful, proper, and timely information that civil and governmental organisations can use, there are three types of data for urban planning: physical data, socioeconomic data from surveys, and physical data related to built environments (Konomi and Roussos, 2017). So, the approach of public participation geographic information system (PPGIS) helps in achieving the concept of placemaking with creative ambiance as they both work on studying and analysing the physical and non-physical aspects of the users’ environments.

4. Materials and Methods

To achieve the aim of the research, a four-step procedure was taken. First, the authors formulated and selected the items to evaluate based on

REDEFINITION OF HERITAGE PUBLIC SPACES USING PPGIS: THE CASE OF RELIGIOUS COMPLEX IN OLD CAIRO

placemaking criteria, for example, the activities of users and attractive nodes in heritage public spaces. The chosen case study was selected upon differences between them in three independent variables; built environment, social activities, and cultural heritage. The case study is full of rich and deep cultural heritage. It also raises various socio-economic dynamics and historical backgrounds. Second, the authors build a new design and construct the PPGIS interface. Third, the authors start to distribute the PPGIS survey using Google maps; and finally, a performed statistical, spatial analysis and qualitative interpretation done.

4.1 ITEMS SELECTED

The researcher evaluated this heritage public spaces by considering the seven items of Project for Public Spaces (PPS). Project for Public Spaces (PPS) makes a development in the basic criteria diagram that are divided into four sections: ‘‘Access & Linkage, Comfort & Image, Uses & Activities, and Sociability(PPS, 2010). This new diagram contains many key attributes and new measurements for placemaking, which can be applied to any public spaces, as shown in figure 5 (PPS, 2010).

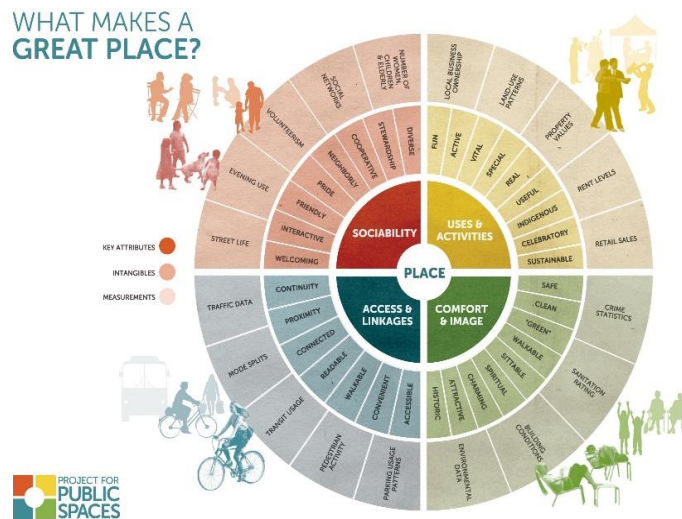

Figure 5. Placemaking Criteria required to create successful spaces
(Source : PPS 2010)

4.2. PPGIS SURVEY INTERFACE

PPGIS was designed as a spatial online survey in Google maps. The survey’s base map was taken from Google Maps and imported to GIS. In the survey we start to evaluate items by rating items in the place and locate them on the base map on GIS. The survey is divided into four sections with a total of

twenty-five questions. The first section is composed of five questions about Access & Linkage. The second section asked participants about Comfort & Image on a spatial basis by using interactivity. This section contains ten questions. The third section is on Uses & Activities; they were asked to place and rate items about this heritage public space location on the map (Figure 6).

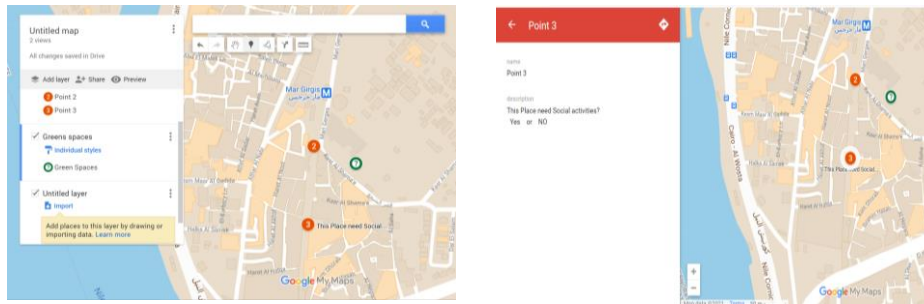

Figure 6. Screenshot of the online survey (Google Earth, 2021).

To evaluate this section, we chose a score rate. The scores were set in five categories: “very satisfied”, “quite satisfied”, “satisfied”, “quite dissatisfied”, and “very dissatisfied”. The fourth section asked participants ten questions on the Sociability in these heritage public spaces. Before answering this section, the author demanded they read background information and a briefing on instruction how to answer survey. This section gives the participants multiple answers to choose from. Respondents’ opinions were about their social interaction in these heritage public spaces and their community attachment and engagement in the enhancing process. The responses were in the form of Likert scale (the five Likert scale varies from 1 to 5, as 1=strongly disagree, to 5=strongly agree).

4.3 DATA ANALYSIS

The results of a spatial online survey in Google maps were analysed statistically and spatially to achieve the qualitative approach. These results help to interpret the problem of the studied area. Excel 2013 was used to collect statistical data to import actual data on ArcGIS 10.4. GIS was used for spatial analysis and mapping which helped correlating locations and it was more accurate than Google Maps. This base map will help in the improving and enhancing of the studied area based on deep survey.

5. Studied Area

This study was conducted in one of the largest religious complexes in Egypt, old Cairo. It has a lot of unique churches as well as the Jewish temple and

REDEFINITION OF HERITAGE PUBLIC SPACES USING PPGIS: THE CASE OF RELIGIOUS COMPLEX IN OLD CAIRO

Amr Ibn el Aas mosque. The public space in this heritage complex is unique and rare as it is home to three monotheistic religions (Elgobashi and Elsemary, 2020a). The area attracts over 1000 and more visitors daily for various purposes, who enjoy the unique historical architecture scenery, Religious sprite, visiting museums, shopping in the traditional Souq and tourism.

This studied area has a special interest which can help in promoting it; it is the surrounding public spaces as it is full of social and cultural value. Those spaces have been neglected without any numerous managements and improvement to attract more visitors.

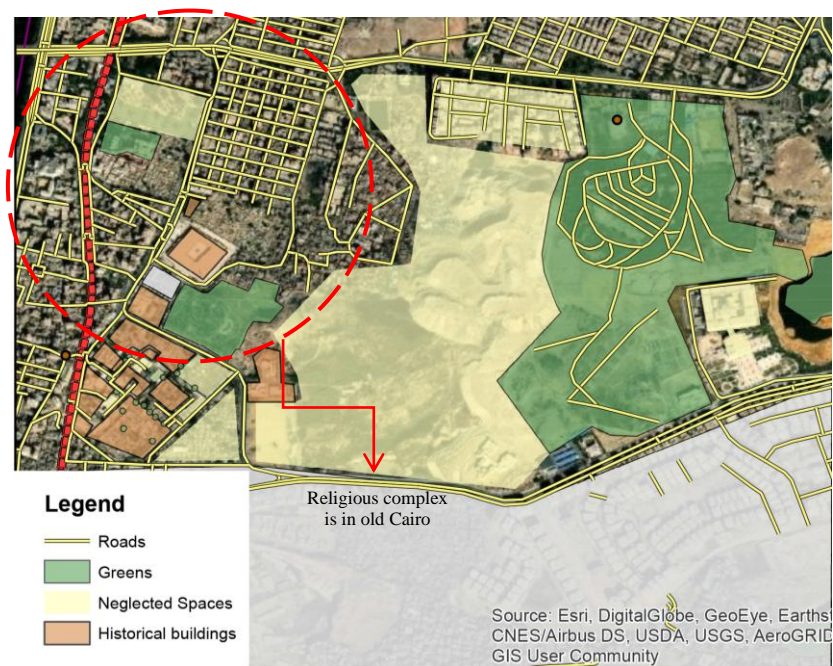

Figure 7. Illustrated by the authors. Shows case study location using ArcGIS 10.4 (Authors,2020).

6. Results

The results were based on online survey, quantitative and spatial analysis. The online survey was done over a six-month period in the studied area. The researcher collected 200 valid surveys and mapped 1500 georeferenced opinions. To get georeferenced maps for the studied area we converted survey and spatial analysis into integrated vector feature classes. This map will show identified locations, access points, attractive area, needed services, needed social activities and green space whether it is neglected or used by users as shown in Figure.8.



Figure 8. Identified locations, access points, attractive area, needed services, needed social activities and green space whether it is neglected or used by users (Authors,2020).

The following figures show the people’s opinion about their social interaction in these heritage public spaces and their community attachment and engage in the enhancing process. Respondents’ answers are in the form of a Likert scale (the five Likert scale varies from 1 to 5, as 1=strongly disagree, to 5=strongly agree) as shown in figure 10.

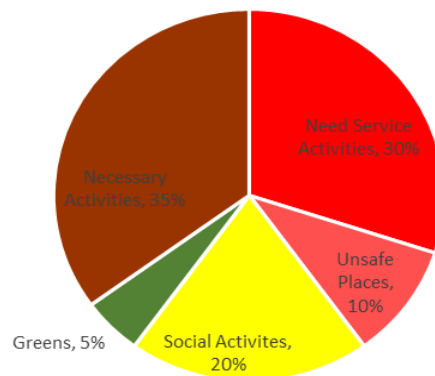

Figure 9. Percentage of needs, path, and network analysis (Authors,2020)

REDEFINITION OF HERITAGE PUBLIC SPACES USING PPGIS: THE CASE OF RELIGIOUS COMPLEX IN OLD CAIRO

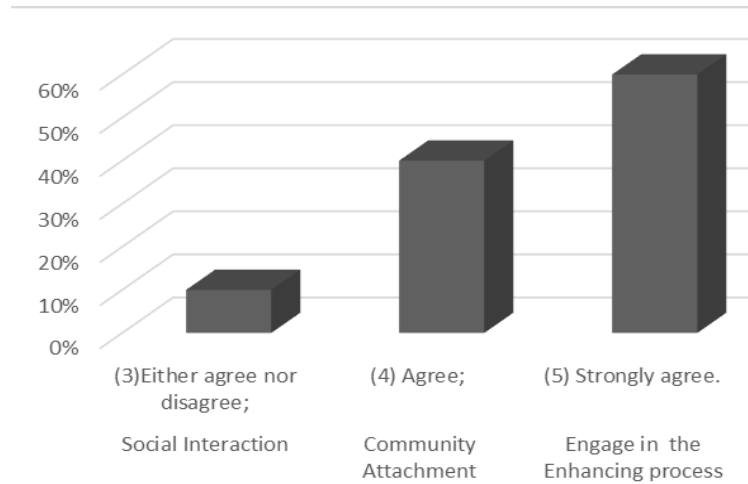

Figure 10. Shows the percentage of people's opinion about their social interaction in these heritage public spaces and their community attachment and engage in the enhancing process (Authors,2020)

After observing and analysing all the collected data in the case study, this heritage site is unique and in a landmark location. The surrounding spaces are huge enough to help the preservationist to add creative atmosphere and ambiance by adding events, exhibitions area, and social activities with the same spirit of the building. It is worth saying that the surrounding buildings have unique architecture, so the attached space should help to reflect and define it for the users. This reflection will be done if the attached space supports the buildings by engaging activities for achieving the main aim of the research for better social quality of life. PPGIS framework was proposed, which gives guidelines to the problem. These guidelines will help to overcome the social problem users face nowadays in the attached space in heritage sites.

The results of this evaluation have a significant impact and opportunity to make this heritage site with its attached spaces more attractive and full of more activities (Elgobashi and Elsemary, 2020b) Nevertheless, the setting suffers a lot of negative issues based on the proposed criteria. Such activity needs and unsafe places leave a negative impression in their minds as shown in figure 9&10. 75% of the respondents mention that they need more commercial, social, recreational, and cultural activities. They suggest that those heritage public spaces undergo a critical development to improve the sense of belonging and pride of the place. This improvement will significantly impact the user's social behaviours and perception in utilising the heritage spaces. Moreover, 70 % of the respondents linked their feeling of attachment and sense of place to the process of improving this heritage public space. If these places are available for the public with useful

attraction, new social bonds and cohesion will exist between the community categories. This bond is one of the essential placemaking credibility outcomes. The respondents need varied activities with a new spirit full of hospitality and attraction of social network. All respondents expressed their desire to participate in this process by criticizing, developing, and voting on the proposals.

7. Conclusion

In this paper, the researcher proposed placemaking with creative ambiance criteria. The aim of this research is to evaluate the social and spatial experience of local populations, using public participation geographic information system (PPGIS) methodology, to explore the relationship between events, their understanding of the built environment and culture. To achieve the research aim, a proposed quantitative and spatial analysis was proposed by examining the activities of users and attractive nodes in heritage public spaces. The studied area was selected based on differences within three independent variables; built environment, social activities, and cultural heritage. In this research, the authors follow a framework for evaluating participation methods. To achieve their aim, they employed participatory mapping and Geographic Information Systems.

This research uses participatory mapping and GIS methodologies to increase our understandings of how users perceive and interact in a range of activities in heritage public spaces. This collaborative participatory approach will capture the diversity of interactions of people. In comparison, it is more 'available' and attractive for people unable to translate their experiences into scales. PPGIS methodology revealed that 75% of the respondents mention that they need more commercial, social, recreational, and cultural activities. They suggest that those heritage public spaces undergo a critical development to improve the sense of belonging and pride of the place. This improvement will significantly impact the user's social behaviours and perception in using the heritage spaces.

Moreover, 70 % of the respondents linked their feelings of attachment and sense of place to the process of improving this heritage public space. It was concluded that (PPGIS) methodology is a more effective participation method to validate the idea and test any criteria. This analysis found PPGIS to be effective and interesting in public heritage spaces. We truly believe in the fact that the management strategies, environmental growth projects and consensus-based decision-making will benefit from this approach tremendously. Further research will focus on public use, attitudes and behaviour of the users. Another important research will concentrate on the proposal or a trial of development in 3D visualization those spaces based on PPGIS methodology that can deliver interesting and attractive places for users.

REDEFINITION OF HERITAGE PUBLIC SPACES USING PPGIS: THE CASE OF RELIGIOUS COMPLEX IN OLD CAIRO

5. References

- Abdel Tawab, A.G., 2014. The World Heritage Centre's approaches to the conservation of New Gurna Village, and the assessment of its authenticity and integrity. *Alexandria Engineering Journal* 53, 691–704. <https://doi.org/10.1016/j.aej.2014.01.010>
- Alan, F., 2016. Global Information Society Watch 2016 Economic, social and cultural rights and the internet.
- Assem, H., El-Sayed, M., 2018. Redefining Heritage Public Spaces for Cultural Events through the Use of GIS Technology: The Case of El Azhar Street-Cairo. H. and El 10.
- Brown, G., Fagerholm, N., 2015. Empirical PPGIS/PGIS mapping of ecosystem services: A review and evaluation. *Ecosystem Services* 13, 119–133. <https://doi.org/10.1016/j.ecoser.2014.10.007>
- Czepkiewicz, M., Snabb, K., 2013. 'Lean' Public Participation GIS: towards a sustainable tool for participatory urban planning. Conference: GIS Ostrava 2013 - Geoinformatics for City Transformation.
- Elgobashi, A., Elsemary, Y., 2020a. Heritage Sites: Towards Creative Ambiance in Public Spaces Attached 15.
- Elgobashi, A., Elsemary, Y., 2020b. Theorizing-the-Critical-Placemaking_Impact-of-Creative-Ambiance-on-Social-Activities, in: Abusaada, H., Salama, A.M., Elshater, A. (Eds.), *Reconstructing Urban Ambiance in Smart Public Places*, Advances in Civil and Industrial Engineering. IGI Global. <https://doi.org/10.4018/978-1-7998-3856-2>
- García-Esparza, J.A., Altaba Tena, P., 2020. A GIS-based methodology for the appraisal of historical, architectural, and social values in historic urban cores. *Frontiers of Architectural Research* S2095263520300297. <https://doi.org/10.1016/j.foar.2020.04.004>
- Giannopoulou, M., Vavatsikos, A.P., Lykostratis, K., Roukouni, A., 2014. Using GIS to Record and Analyse Historical Urban Areas. *Tema. Journal of Land Use Mobility and Environment, transportation and sustainability of the urban system*. <https://doi.org/10.6092/1970-9870/2525>
- Harris, T., Craig, W., Weiner, D., 2002. Community participation and geographic information systems, in: Harris, T., Craig, W., Weiner, D. (Eds.), *Community Participation and Geographical Information Systems*. CRC Press. <https://doi.org/10.1201/9780203469484.pt1>
- Hasse, J.C., 2001. A ROLE FOR PARTICIPATORY APPROACHES AND GIS 294.
- He, Y., Ma, Y.H., Zhang, X.R., 2017. "DIGITAL HERITAGE" THEORY AND INNOVATIVE PRACTICE. *Int. Arch. Photogramm. Remote Sens. Spatial Inf. Sci.* XLII-2/W5, 335–342. <https://doi.org/10.5194/isprs-archives-XLII-2-W5-335-2017>
- Hu, Y., Lv, Z., Wu, J., Janowicz, K., Zhao, X., Yu, B., 2015. A multistage collaborative 3D GIS to support public participation. *International Journal of Digital Earth* 8, 212–234. <https://doi.org/10.1080/17538947.2013.866172>
- Konomi, S., Roussos, G. (Eds.), 2017. *Enriching Urban Spaces with Ambient Computing, the Internet of Things, and Smart City Design*, Advances in Human and Social Aspects of Technology. IGI Global. <https://doi.org/10.4018/978-1-5225-0827-4>
- Lynch, K., 2005. *The image of the city*, Nachdr. ed, Publication of the Joint Centre for Urban Studies. MIT PRESS, Cambridge, Mass.
- McKinnon, J., 2001. *Mobile Interactive GIS: Bringing Indigenous Knowledge and Sci* 13.
- Meddan, D., 2012. *Cities Full of Symbols: A Theory of Urban Space and Culture*. Leiden University Press.
- Nikonova, A.A., Biryukova, M.V., 2017. The Role of Digital Technologies in the Preservation of Cultural Heritage 5.
- Ognjanović, Z., Marinković, B., Šegan-Radonjić, M., Masliković, D., 2019. Cultural Heritage Digitisation in Serbia: Standards, Policies, and Case Studies. *Sustainability* 11, 3788. <https://doi.org/10.3390/su11143788>
- Palacio Buendía, A.V., Pérez Albert, M.Y., Serrano Giné, D., 2019. PPGIS and Public Use in Protected Areas: A Case Study in the Ebro Delta Natural Park, Spain. *IJGI* 8, 244. <https://doi.org/10.3390/ijgi8060244>
- Petronela, S.-U., Ursu, A., Sandu, I., 2016. HERITAGE MANAGEMENT USING GIS.
- PPS, P. for public spaces, 2010. PLACEMAKING MEETS PRESERVATION [WWW Document]. URL <https://www.pps.org/article/placemaking-meets-preservation>

A. ELGOBASHI AND Y. EL SEMARY

- Rahaman, H., 2018. Digital heritage interpretation: a conceptual framework. *Digital Creativity* 29, 208–234. <https://doi.org/10.1080/14626268.2018.1511602>
- Relph, E., 2008. *Place and placelessness*. Pion Ltd; UK ed. edition.
- Saadallah, D.M., 2020a. Utilizing participatory mapping and PPGIS to examine the activities of local communities. *Alexandria Engineering Journal* 59, 263–274. <https://doi.org/10.1016/j.aej.2019.12.038>
- Saadallah, D.M., 2020b. Utilising participatory mapping and PPGIS to examine the activities of local communities. *Alexandria Engineering Journal* 59, 263–274. <https://doi.org/10.1016/j.aej.2019.12.038>
- Sieber, R., 2006. Public Participation Geographic Information Systems: A Literature Review and Framework. *Annals of the Association of American Geographers* 96, 491–507. <https://doi.org/10.1111/j.1467-8306.2006.00702.x>
- Steinmann, R., Krek, A., Blaschke, T., 2004. ANALYSIS OF ONLINE PUBLIC PARTICIPATORY GIS APPLICATIONS WITH RESPECT TO THE DIFFERENCES BETWEEN THE US AND EUROPE 13.
- Stewart, E.J., Jacobson, D., Draper, D., 2008. Public participation geographic information systems (PPGIS): challenges of implementation in Churchill, Manitoba: Public participation geographic information systems (PPGIS). *The Canadian Geographer / Le Géographe canadien* 52, 351–366. <https://doi.org/10.1111/j.1541-0064.2008.00217.x>
- Townley, G., Kloos, B., Wright, P.A., 2009. Understanding the experience of place: Expanding methods to conceptualize and measure community integration of persons with serious mental illness. *Health & Place* 15, 520–531. <https://doi.org/10.1016/j.healthplace.2008.08.011>
- UNESCO, U., 2009. Charter on the Preservation of the Digital Heritage 5.
- Willet, K., 2001. An Interactive GIS Approach in Open Space Planning Using a Multiple Criteria Ranking System.

PHENOMENOLOGICAL BIM DESIGN EVALUATION OF INDOOR SPATIAL CONFIGURATIONS

NORAN ELBAZ, MOHAMED EZZELDIN

Ain Shams University, Egypt

Email address: elbaz_noran@yahoo.com

Email address: mohamed.ezzeldin@eng.asu.edu.eg

Abstract. The studies of evaluating spaces' different spatial configurations mostly cover the physical dimensions; especially when using digital platforms such as BIM. The gap between the physical dimension of abstract spaces, and the metaphorical senses of these places, has always been a missing layer when testing the quality of space. The current BIM tools – as a digital platform – are mostly based only on physical dimensions of spaces, where the phenomenological approach is not considered as one of the layers or attributes when evaluating the spatial configurations of indoor spaces. This missing layer of the user perceptual experience leads to incomprehensive results of spatial design evaluation. This paper aims to identify the gap between the qualitative and quantitative studies of space configurations and the experiential dimension of indoor spaces in order to increase the accuracy of design evaluation by filling the missing gaps through adding; to the spatial configurations of physical 'Space' another dimensions and attributes that are related to senses of 'Place,' highlighting the need of creating a SIM, "Sensory Information Modeling," a digital platform for Places integrated with BIM for Spaces.

Keywords: *BIM, SIM, Space, Place*

ملخص. إن دراسات تقييم المكان في الأغلب تتعلق بالأبعاد المادية للفراغ خاصة عند استخدام المنصات الرقمية مثل ال BIM. إن الفجوة بين البعد المادي للأماكن كفراغات مجردة والحواس المجازية لهذه الأماكن دائما ما كانت بعدا مفقودا عند اختبار جودة المكان. تعتمد أدوات ال BIM الحالية - كمنصة رقمية - في الأغلب على الأبعاد المادية للمكان ، في حين لا يتم الإهتمام بالمكان كظاهرة حسية و كأحد السمات الهامة عند تقييم الأبعاد المكانية للفراغات الداخلية. يؤدي افتقاد هذا البعد الهام في دراسة تجربة المستخدم الإدراكية إلى نتائج غير مكتملة عند تقييم التصميم المكاني. تهدف هذه الورقة إلى تحديد الفجوة بين الدراسات النوعية والكمية لأبعاد المكان والبعد التجريبي للفراغات الداخلية من

أجل زيادة دقة تقييم التصميم من خلال إضافة ؛ السمات المتعلقة ب حواس "المكان" إلى أبعاده المادية ، من خلال إبراز الحاجة إلى إنشاء SIM ، "نمذجة المعلومات الحسية" ، وهي منصة رقمية للأماكن المدمجة تجمع مابين إمكانيات ال BIM و مايمثله من أبعاد مادية للفراغ و الجوانب الحسية للمكان.

الكلمات المفتاحية: المكان، الفراغ، نمذجة معلومات المبنى، نمذجة المعلومات الحسية.

1. Introduction

This paper aims to introduce a novel approach concerning Architectural design evaluation; it considers future directions for BIM through a literature review addressing various case studies. First, it elaborates the phenomenology of space and place, then relating this issue to Building Information Modelling and illustrating the missing dimensions of BIM-based design evaluation. Ending with introducing the Sensory Information Modelling SIM as a novel approach for covering the missing design evaluation dimensions.

2. BIM and Phenomenology of Space and Place

According to Tuan's definition, 'Space' is physical and abstract, while 'Place' gives the values of meanings, senses, and emotions (Tuan, 2001). Space is opened, dynamic, free, and physical, while Place is enclosed, static, stable, and humanist. Space represents the context, while Places give them the meaning. Spaces can be transformed to Places through social and human interactions (Mohamed Ezzeldin; Ayman Assem, 2019). Phenomenology is an interpretation of human experience, Edward Relph has taken that approach of studies when defining the term of 'Place.' The phenomenological approach identifies the meanings of space and place according to the human experience through qualitative studies, capturing people's interactions in physical spaces, and interpreting these experiences into meanings of emotions and impressions (David Seamon & Jacob Sowers, 2008). The sense of place, in phenomenological studies identifies qualitatively the perception and interpretation of place, expressing how people 'feels' and 'senses' these spaces (Perdikogianni, 2007).

2.1. SENSE OF SPACE AND PLACE

Canter in 1977, defined place main elements as a dynamic relation between physical attributes of space (spatial configurations and built environment), conceptions (meanings, motions, senses, and feelings) and activities (social and human interactions). Montgomery in 1998 developed Canter model and

PHENOMENOLOGICAL BIM DESIGN EVALUATION OF INDOOR SPATIAL CONFIGURATIONS

added the physical setting, activity, and image as three main components of any place (Rasouli 2013), as shown in figure 1.

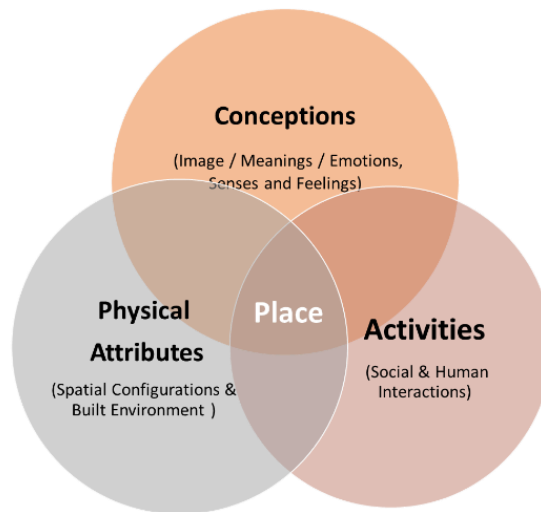

Figure 1. Canter (1977) & Montgomery (1998) Basic Elements of Place.

The human experiences and time were the common factors in modifying and changing both space and place, giving uniqueness to some places while other spaces lack of that presence. That concept was defined by Tuan (2001) and Relph (1976) as a 'Sense of Place.' (Sarikulak 2013). The Theory of 'The social production of space,' introduced by Henri Lefebvre in 1991, defined how a physical 'Space' is being transformed through an endless and a continuous process of social production of human experiences and activities into a meaningful 'Place' full of senses and emotions (Parkinson 2012). Figure 2 shows the 3 different levels of this theory. BIM, GIS, spatial morphology, axial lines, convex spaces and isovisits and other digital integrated data base systems used often to study the physical perceived space, focusing on the physical attributes, settings, functions, built environment (Perdikogianni 2007). This research highlights the need of gathering the sensory information different models of places in one digital platform, integrating the physical attributes with the temporal human experiences of the living space producing conceived sense of place (Mohamed Ezzeldin; Ayman Assem 2019).

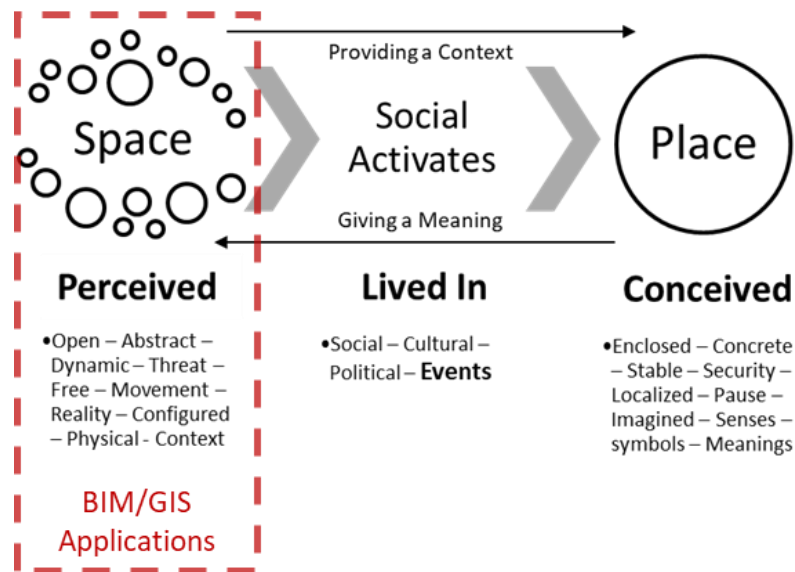

Figure 2. BIM and GIS common applications and Henri Lefebvre (1991) theory of the social production of space. (Mohamed Ezzeldin; Ayman Assem 2019).

2.2. BIM MISSING DIMENSIONS OF PLACE

David Seamon & Jacob Sowers (2008) introduced Edward Relph's three main elements of place as: the physical (Spatial), the historical (Temporal) and the cognitive (Social) (Mohamed Ezzeldin; Ayman Assem 2019). BIM and GIS focused on the spatial dimensions represented in GIS database maps, and through integrated information models in BIM, giving a chance for urban and architecture design decisions and per-occupancy evaluations to take place in both urban and indoor spaces (Cighi May 2008). As introduced, the sense of place is created during the time people experiencing the spatial configurations of space, creating their own meanings, emotions, senses, feelings, impressions and memories and giving that place its temporal and social dimensions (Steve Harrison & Paul Dourish 1996).

The applications of BIM focused more in defining the physical Space, missing the values and senses of Place. Studying these human experiences, and evaluating the indoor spatial configurations through a phenomenological approach in different design phases using BIM, became a need to test and examine how people will interact with these spaces (preoccupancy studies), not only how these spaces will be built or environmentally will behave. As shown in figure 3, BIM gave the chance to examine the spatial and physical configurations, while it missed the space as a phenomenon, and how it is being lived-in as a place.

PHENOMENOLOGICAL BIM DESIGN EVALUATION OF INDOOR SPATIAL CONFIGURATIONS

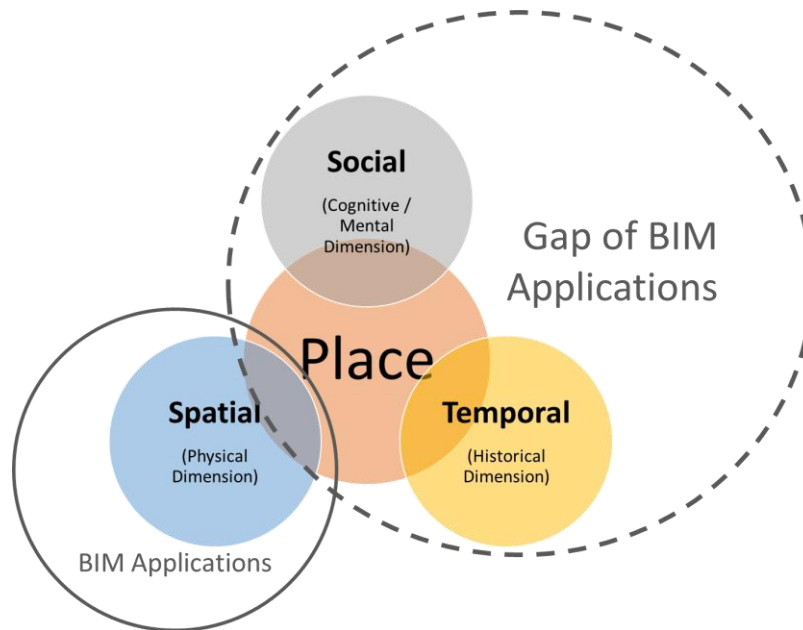
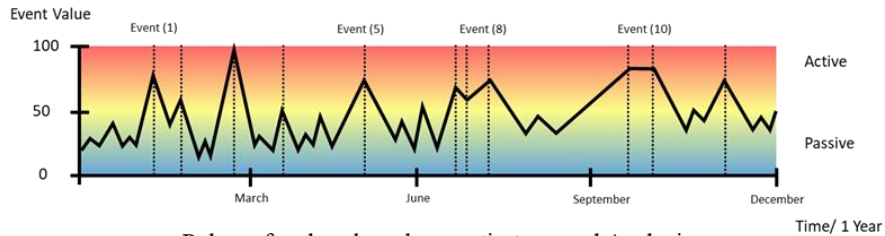
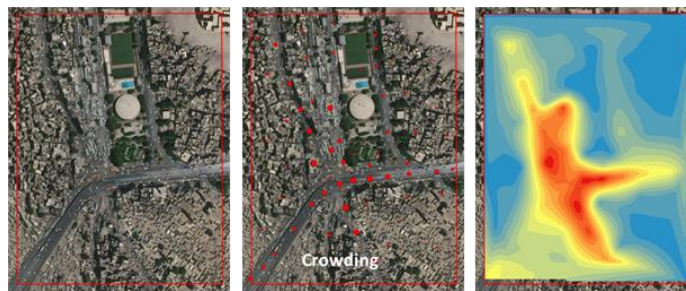

Figure 3. BIM Missing Dimensions of Place.

The integration between the spatial, temporal, and social dimensions has been a research interest in both urban and indoor spaces. The spatio-temporal analysis shown in figure 4 is an example of integrating the three dimensions of place; spatial, social and temporal using a GIS based, creating emotional maps that represent the people experiences in public spaces during different social events. Such a spatial tool gives the ability of creating a dialogue map exploring the different human interactions, feelings, emotions during or pre-occupying the space, and evaluating the produced sense of place. The potential of such spatio-temporal analysis could be applied in BIM for Indoor spaces giving the chance for architects to pre-evaluate the people experience of spaces and to examine the designed identity of these places; describing their emotions and feelings during their active or passive engagement interactions with these spaces through emotional pulses of these places (Mohamed Ezzeldin; Ayman Assem 2019).



Pulses of a place based on spatio-temporal Analysis.



Sample of spatio-temporal analysis of crowding, Sida-Aesha Square.

Figure 4. Examples of Spatio-Temporal Analysis using the GIS for urban public spaces (Mohamed Ezzeldin; Ayman Assem 2019).

2.3. BIM INDOOR SPATIAL CONFIGURATIONS

As introduced, space is the physical dimension of place; all the spatial configurations are designed to achieve the users' needs and requirements targeting their maximum satisfaction level (Suncheol Naa, Seung Wan Hong, Sungwon Jung, Jaewook Lee, 2020). 'Building Information Modeling,' (BIM) is defined as a digital integrated database system that represents that physical dimension of any place. BIM is basically oriented towards, the industry of construction, giving the benefits of saving time and money with high level of efficiency in coordination between multi disciplines, giving the benefit of an efficient performance of engineering practice through different design and construction phases (Ning Wang, Raja R.A. Issa, 2020). BIM also gave a promising edge in renovation and maintenance phases, and theoretically; it can be used as prediction tool (Yi-Kai Juan, Nai-Pin Hsing). The 'Lived-In' physical space where people have their social experiences and human interactions, (Mehul Bhatt, Christoph Hölscher, Thomas F. Shipley., 2011) is transformed into a 'Conceived Place' through a social production of place as introduced before in Henri Lefebvre (1990) theory. BIM evolution gave the potential of tracking objects in a spatial array where they can be navigated through cognitive maps of indoor spaces (Matlin, 2009). These competitive edge gave the possibility of the

PHENOMENOLOGICAL BIM DESIGN EVALUATION OF INDOOR SPATIAL CONFIGURATIONS

integration between art and design, analysis and synthesis, technology and creativity, (Mehul Bhatt, Christoph Hölscher, Thomas F. Shipley., 2011) and eventually; between the physical perceived space and the meaningful conceived place.

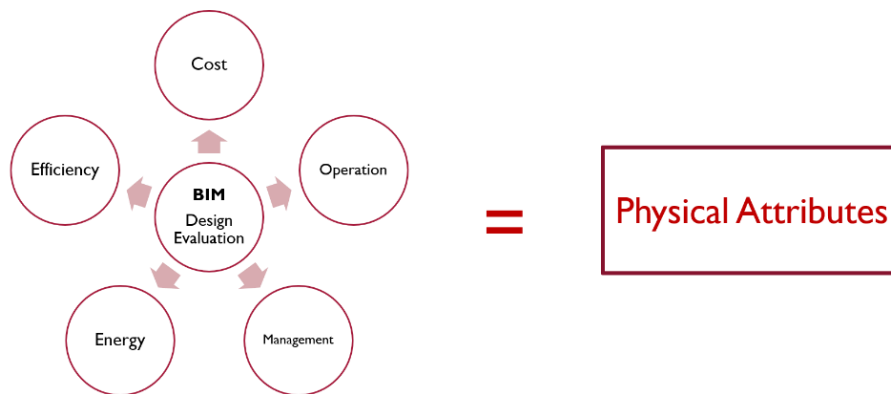

Figure 5. BIM Design Evaluation and the different Physical attributes.

The performance of the indoor spatial configurations can be measured through the method of Post Occupancy Evaluation (POE), where it conducts the user satisfaction during a specific time duration, using different types of observation and in-depth interviews. In POE is used to evaluate the space after the construction, measuring to what level the users will be satisfied. It tests the values and meanings of place as well as the physical spatial satisfaction. (Suncheol Naa, , Seung Wan Hong, Sungwon Jung, Jaewook Lee, 2020). The POE gives the potential of testing the meanings of 'Place' . The action of these real users in post occupied spaces gives a high indications of the performace of these spaces and to what level they succeeded to be transformed into lived-in places, achieving the pre-designed identity for these spaces (Suncheol Naa, , Seung Wan Hong, Sungwon Jung, Jaewook Lee, 2020).

3. BIM and GIS Indoor Spatial Evaluation

The BIM platforms provide detailed indoor environment because of the rich architectural semantic information in addition to the intrinsic geometric information which results in a simple process of indoor spatial data collection and represent data sources for indoor GIS models (Qingxiang Chen , Jing Chen, Wumeng Huang , 2020). The idea of Geographic

Information System (GIS) was introduced in the 60's in order to utilize a computerized system for capturing, storing, and analyzing spatial data; and this data is represented as positions, attributes related to reality (Ning Wang, Raja R.A. Issa, 2020). The BIM is widely applied in the architectural, engineering and construction industry, in addition to the aggregation of the indoor geospatial data into BIM models. Where the indoor routing is based on the Geographic Information System (GIS), Many researchs have been resolving the interoperability process between BIM and GIS platforms in order to integrate BIM and GIS for indoor routing through Utilizing the industry foundation classes (IFC) data format which could be produced from the BIM models. By using IFCOpenShell the indoor geospatial data could be generated from the BIM models and integrated with GIS indoor ontology (Ning Wang, Raja R.A. Issa, 2020). The Indoor routing Focuses on determining the optimal Navigation scenario between two location points in a building (Ning Wang, Raja R.A. Issa, 2020). The main element in the indoor space navigation is the path planning algorithm (Guofeng Ma, Xue Song, Shanshan Shang, 2020 Volume 26).

4. BIM Experiential Attributes

The user's spatial satisfaction is the main aspect in evaluating the quality of spaces, it represents how far the architecture succeeded in fulfilling the requirements and needs of the users either in function or psychological comfort and aesthetic value (Suncheol Naa, , Seung Wan Hong, Sungwon Jung, Jaewook Lee, 2020). In order to evaluate the user's spatial satisfaction the process of post occupancy evaluation (POE) has been carried. However it is oriented into the existing buildings in order to upgrade their spatial impact. Another way of evaluation has been introduced which is Pre-Occupancy Evaluation (PrOE) where the spatial configuration could be evaluated before construction (Suncheol Naa, , Seung Wan Hong, Sungwon Jung, Jaewook Lee, 2020). This could be done through creating virtual users imitating the real users responses in real physical spaces and applying it on the virtual spaces. It is based on the simulation approach to evaluate the spaces quantitatively giving accurate results same as reality (Suncheol Naa, , Seung Wan Hong, Sungwon Jung, Jaewook Lee, 2020), as shown in figure 6.

The problem is as far as we can see that the evaluation trials carried till now is only evaluating a frozen image neglecting the experiential aspect of place mentioned before. For example figure 7 where the working area is evaluated from the furniture aspect and ventilation but on the right appears the real spirit of the working space and how it reflects on the productivity of the users.

PHENOMENOLOGICAL BIM DESIGN EVALUATION OF INDOOR SPATIAL CONFIGURATIONS

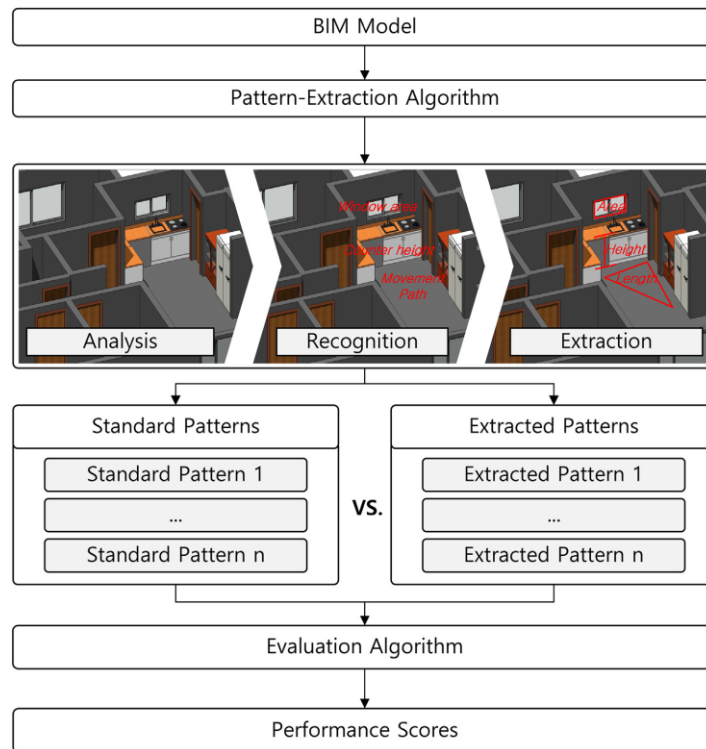

Figure 6. Performance evaluation process. (Suncheol Naa, , Seung Wan Hong, Sungwon Jung, Jaewook Lee 2020)



Figure 7. Frozen Image vs. reality in Working space (United BIM n.d.).

Another example shown in figure 8 and how the residential space is evaluated through the environmental analysis, neglecting the real-life activities and the fact of that the family members life and memories are growing in that space.

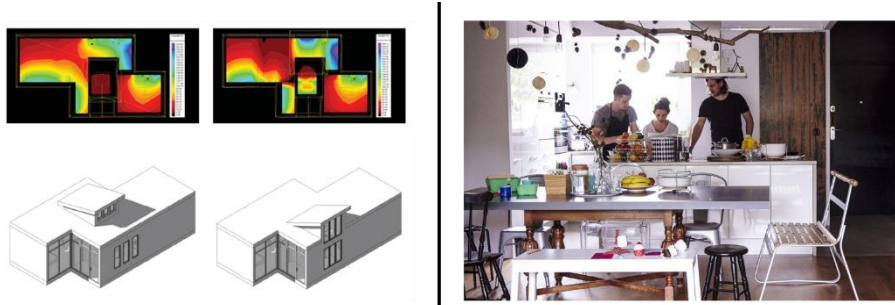

Figure 8. Frozen Image vs. reality in residential space (American Institute of Architects, n.d.).

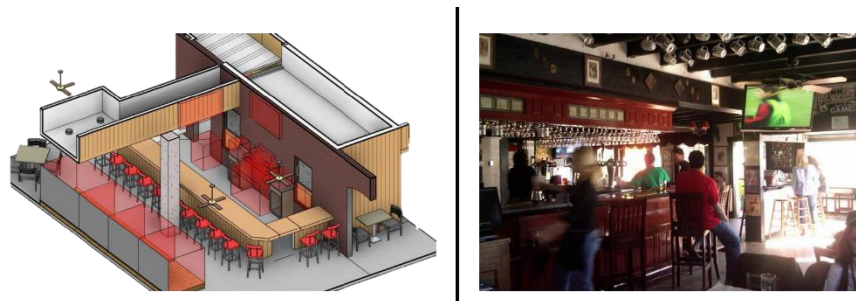

Figure 9. Frozen Image vs. reality in a café bar (SOA Architecture, n.d.).

Ending with the example of the Louvre museum in Abu Dhabi (figure 10), where a novel experiential journey is created by Architect Jean Nouvel, the question is: could spatial configuration like this be evaluated in BIM?

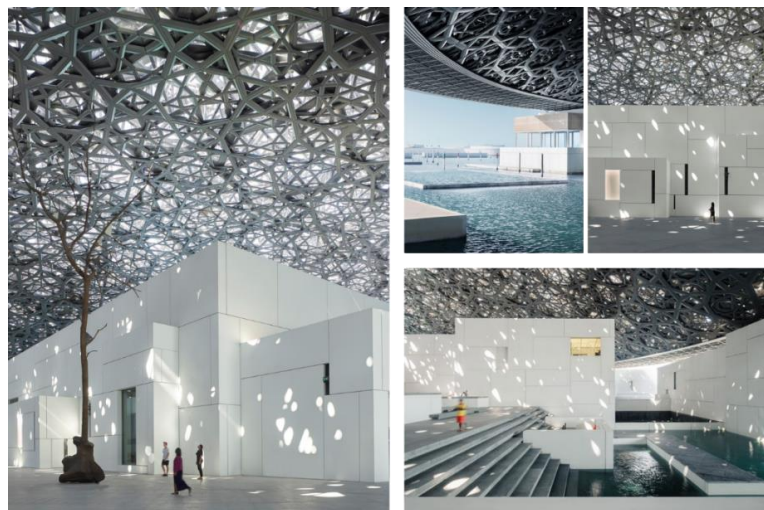

Figure 10. Louvre Abu Dhabi Museum (The Ateliers Jean Nouvel n.d.)

5. Sensory Information Modelling

Virtual reality provides sensory information of user's adequate precision of space (Visualization Using Virtual Reality, 2005), where virtual reality displays offer high spatial perception by empowering user's senses. It is used to create memorable experiences using spatial mnemonic where users could recall information through organizing it spatially in an environment (Eric Krokos, Catherine, Plaisant Amitabh Varshney, 2018). The virtual reality technology has grown rapidly in the past years and it became a user friendly web-based technologies, it has opened up to different platforms such as GIS; and it became an open-source solutions thanks to game engine platforms (Baumgartinger-Seiringer, 2020). Through years several trials have been carried out order to integrate GIS and VR for visualization of spatial information in an interactive system (Bo Ren, Qing Jiang, Li-jun Li, Cheng Wang, 2005). Also, trials of data models integrating GIS, VR, and the Internet. Models with different levels that are interoperable. The data model could be represented in different ways. And all of them could be displayed and operated on the network (Wenyang Yu, Chongjun Yang, Feixiang Chen, Jianyu Yang, Xiaoqi Le, 2005). So, virtual reality has become a commonly used tool for visualizing GIS, where users can navigate through 3D environments (Gert van Maren, Rick Germs, Frederik Jansen, 1998). Where in the BIM platforms, the architectural visualization is one the main outputs, but it is limited to specialists only, integrating BIM platforms with Game engine platforms results in an upgraded user experience of spaces (Noran Elbaz, Shaimaa Kamel, Sherif Abdelmohsen 2020), by aligning that integration with GIS we get the Sensory information Modelling (SIM), which this paper presents as novel approach for phenomenological indoor spatial evaluation, where a real time experience is presented to the future occupants of the building in the designing phase in order to evaluate all aspects of space the tangible and intangible features.

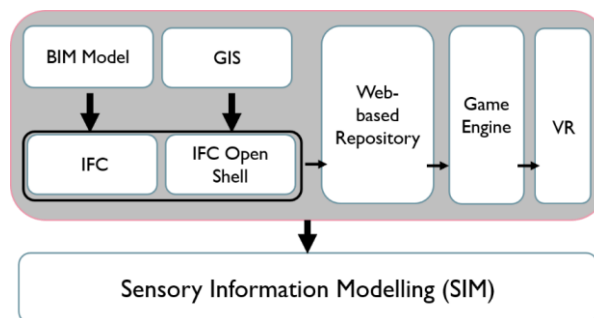

Figure 11. The Sensory information Modelling.

6. Conclusion

The research concluding that by integrating Building Information Modelling, Geographic Information System and Game Engine, it give the avaliability to establish a novel system of a “Sensory Information Modelling” that allows the users of the indoor spaces to test the exprential aspects in addition to physical aspect of spaces, in order to result in a comprehensive indoor spatial evaluation as well as testing the values senses of place as shown in figure 12. This novel approach; this paper has introduced through a literature review addressing various case studies concerning Architectural design evaluation; it considers the future directions for BIM applications.

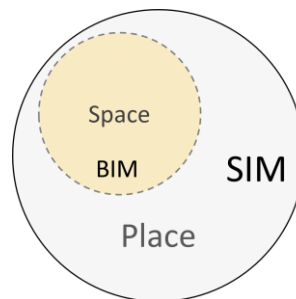

Figure 12. Space and Place between BIM and SIM.

7. References

- Baumgartinger-Seiringer, Mathias. 2020. *Concepts of Virtual Reality in GIS*. University of Applied Sciences Technikum Wien.
- Bo Ren, Qing Jiang, Li-jun Li, Cheng Wang. 2005. "The integration of gis and virtual reality for visualization of battlefield spatial information." *The International Society for Optical Engineering Follow journal*.
- Cighi, Catalin I. May 2008. *Senses of Place*. Master of Science, Department of Hospitality & Tourism Management, Graduate School of the University of Massachusetts Amherst. Accessed February 2014. <http://scholarworks.umass.edu/theses/116>.
- David Seamon & Jacob Sowers. 2008. "Place and Placelessness, Edward Relph." In *Key Texts in Human Geography*, by R. Kitchen, & G. Vallentine P. Hubbard, 43-51. London: Sage.
- Eric Krokos, Catherine, Plaisant Amitabh Varshney. 2018. "Spatial Mnemonics using Virtual Reality."
- Gert van Maren, Rick Germs, Frederik Jansen. 1998. "Integrating 3D-GIS and Virtual Reality Design and implementation of the Karma VI system." *10th Colloquium of the Spatial Information Research Centre*. New Zealand.
- Guofeng Ma, Xue Song, Shanshan Shang. 2020 Volume 26. "BIM-Bsaed Space Managment for Operation and Maintenance Phase in Educational Office Buildings." *Journal of Civil Engineering and Management*.
- Matlin, Margaret W. 2009. *Cognitive Psychology*. John Wiley & Sons.

PHENOMENOLOGICAL BIM DESIGN EVALUATION OF INDOOR SPATIAL CONFIGURATIONS

- Mehul Bhatt, Christoph Hölscher, Thomas F. Shipley. 2011. "Spatial Cognition for Architectural Design." *SCAD 2011 Symposium Proceedings*. New York, USA.
- Mohamed Ezzeldin; Ayman Assem. 2019. "A GIS-Based Spatio-Temporal Analysis for Social Events Carried Out in Urban Public Spaces." *AR-UP 2019: Architecture & Urbanism... A Smart Outlook*. Cairo, Egypt: Elsevier.
- Ning Wang, Raja R.A. Issa. 2020. "Ontology-Based Integration of BIM and GIS for Indoor Routing." *Construction Research Congress*. TEMPE, ARIZONA.
- Noran Elbaz, Shaimaa Kamel, Sherif Abdelmohsen. 2020. "Heritage Building Information Modelling: Towards a New Era of Interoperability." *Architecture and Urbanism: A Smart Outlook*. Springer.
- Panek, Jiri. 2018. "Emotional Maps: Participatory Crowdsourcing of Citizens' Perceptions of Their Urban Environment." *Cartographic Perspectives* 90(2).
- Parkinson, John R. 2012. *Democracy and Public Space*. New York: Oxford University Press .
- Perdikogianni, Irini. 2007. "From Space to "Place": The role of space and experience in the construction of "Place"." *6th International Space Syntax Symposium*. İstanbul. 052:1-14.
- Qingxiang Chen , Jing Chen, Wumeng Huang . 2020. "Method for Generation of Indoor GIS Models Based on BIM Models to Support Adjacent Analysis of Indoor Spaces." *International Journal of Geo-Information*.
- Rasouli, Mojgan. 2013. *Analysis of Activity Patterns and Design Features Relationships in Urban Public Spaces Using Direct Field Observations, Activity Maps and GIS Analysis: Mel Lastman Square in Toronto as a Case Study*. Master of Arts in Planning, Waterloo, Ontario, Canada: University of Waterloo.
- Sarikulak, Selen. 2013. *Changing Identity of Public Spaces: Güven Park in Ankara*. M.Sc. Urban Design, Ankara: Graduate School of Natural and Applied Sciences, METU.
- n.d. *SOA Architecture*. <https://soa-inc.com/how-we-work/bim-services/>.
2020. *Stanford Encyclopedia of Philosophy*. 9. <https://plato.stanford.edu/entries/architecture/tradition.html>.
- Steve Harrison & Paul Dourish. 1996. "Re-place-ing space: the roles of place and space in collaborative systems." *CSCW '96 Proceedings of the 1996 ACM conference on Computer supported cooperative work*. New York, NY, USA: ACM. 67-76.
- Suncheol Naa , Seung Wan Hong, Sungwon Jung, Jaewook Lee. 2020. "Performance evaluation of building designs with BIM-based spatial patterns." *Automation in Construction*.
- n.d. *The American Institute of Architects*. <http://www.tboake.com/carbon-aia/teaching/thomson/thomson8.html>.
- n.d. *The Ateliers Jean Nouvel*. <http://www.jeannouvel.com/projets/louvre-abou-dhabi-3/>.
- Tuan, Yi-Fu. 2001. *Space and Place: The Perspective of Experience*. Minneapolis, London: University of Minnesota Press.
- n.d. *United BIM*. <https://www.united-bim.com/bim-consulting-services/>.
2005. "Visualization Using Virtual Reality." In *Visualization Handbook*.
- Wenyang Yu, Chongjun Yang, Feixiang Chen, Jianyu Yang, Xiaoqui Le. 2005. "An approach for integrating 3D GIS, virtual reality and the internet." *Geoscience and Remote Sensing Symposium, IEEE International Volume 2*.
- Yi-Kai Juan, Nai-Pin Hsing. n.d. "BIM-Based Approach to Simulate Building Adaptive Performance and Life Cycle Costs for an Open Building Design." *MDPI, Applied Sciences, Volume 7, Issue 8*.

D1.P2.S4

TECHNOLOGY INTEGRATION AND COLLABORATION II

THERMAL PERFORMANCE OF NANOMATERIALS OF A MEDIUM SIZE OFFICE BUILDING ENVELOPE

With a Special Reference to Hot Arid Climatic Zone Of Egypt

NOURAN ASHRAF ALI, SAMIR SADEK HOSNY

Faculty of Engineering, Department of Architecture, Cairo University, Cairo University Rd, 12613.

Faculty of Engineering and Technology, Department of Architectural Engineering, FUE, Future University in Egypt, 90th St, First Settlement, New Cairo.

Email address: nouran.ali@fue.edu.eg

Faculty of Engineering and Technology, Department of Architectural Engineering, FUE, Future University in Egypt, 90th St, First Settlement, New Cairo.

Email address: ssadek@fue.edu.eg.

AND

AHMED REDA ABDIN

Faculty of Engineering, Department of Architecture, Cairo University, Cairo University Rd, 12613.

Email address: aabdin@eng.cu.edu.eg

Abstract. Global warming is becoming a huge threat in the 21st century. The building is the main contributor to energy consumption and greenhouse gas emissions which play an important role in global warming. Using new technologies provides a step towards a better-built environment. Nanotechnology is an emerging technology that provides innovative materials that integrate with the building envelope to enhance energy efficiency and decrease energy consumption in buildings. Many Nano products are a promising candidate for building thermal insulation and increasing the building's efficiency. This paper aims to reach minimum energy consumption by investigating Nanomaterials thermal performance on a building's envelope in a hot arid climate. An office building in Cairo, Egypt is chosen as a case study. The paper presents an empirical/applied inquiry that is based on a computer simulation using *Design Builder* software. Energy consumption is calculated for different cases; the base model of the

office building without using nanomaterials, and several nano models using nanomaterials. The results indicate that the use of Nanomaterials can enhance the thermal performance of the office building and save about 13.44 % of the annual energy consumption of the building.

Keywords: *Office Buildings, Building envelope, Energy consumption, Nano insulation materials.*

ملخص. في القرن الحادي والعشرين، التهديد الكبير هو ظاهرة الاحتباس الحراري. المباني هي المساهم الرئيسي في استهلاك الطاقة وانبعاثات غازات الاحتباس الحراري التي تلعب دورًا مهمًا في ظاهرة الاحتباس الحراري. لذلك، فإن استخدام التكنولوجيات الجديدة يعطي خطوة نحو بيئة مبنية بشكل أفضل. تقنية النانو هي تقنية ناشئة في هذا الوقت وتوفر مواد مبتكرة تتكامل مع بناء الغلاف الخارجي للمباني لتعزيز كفاءة الطاقة وتحقيق خفض كبير في استهلاك طاقة المباني. تم إجراء دراسة تجريبية، تستند إلى محاكاة الكمبيوتر، باستخدام برنامج Design Builder لمبنى إداري يقع في القاهرة، مصر. وتم بناء نموذج المبنى في برنامج Autodesk Revit. تم إجراء مقارنة بين استهلاك الطاقة وأحمال التبريد بين نموذج مبنى المكاتب الأساسي مع المواد التقليدية ونموذج النانو باستخدام Nano VIP في السقف و Nano aerogel glazing system و Nano Aerogel based rendering في الجدران. والحصول على نسبة الانحراف حوالي 5٪ بين نموذج الحالة الأساسية وفواتير المرافق للمبنى في عام 2017. تشير النتائج إلى أن استخدام مواد النانو مع غلاف المبنى يعزز الأداء الحراري للمبنى في المناخ الجاف الحار ويظهر أن تكامل مواد النانو مع غلاف المبنى يعطي قيمة قياسية علمية وتجريبية منخفضة لانتقال الحرارة. يتم تقليل استهلاك الطاقة بنسبة 13.44% من استهلاك الطاقة السنوي للمبنى باستخدام مواد النانو.

الكلمات المفتاحية: *استهلاك الطاقة، الغلاف الخارجي للمباني، المباني الإدارية، تكنولوجيا النانو، مواد العزل بالنانو.*

1. Introduction

Global warming has become a serious threat to mankind. Ratings show that there is an annual increase of 1.8% per year of the impact of global warming through 2050, as such, energy conservation is becoming an imperative issue (Akeiber et al., 2016). The building envelope must have thermal protection as it causes great heat loss (Cui, et al. 2015). New technologies such as “nanotechnology” can solve many problems in the building sector (Atwa, 2015). There is a growing interest in the applications of nanomaterials because of their positive impact on thermal properties and energy efficiency (Boostani, 2016). One of the purposes of this paper is to highlight the benefits of nanomaterials in energy conservation.

THERMAL PERFORMANCE OF NANOMATERIALS OF A MEDIUM SIZE OFFICE BUILDING ENVELOPE

2. Nanoarchitecture Applications and Energy Saving

Nanotechnology has many applications in architecture like air purification, water purification, lighting, solar energy, and design. The meaning of nanoarchitecture can be confirmed in nanomaterials and energy sectors (Casini, 2016a).

In the materials sector: 1. Creating Nanostructured materials by adding free or embedded Nano objects with the composite of traditional materials, both solid and liquid as, cement, metals, ceramics, paints to make them nanocrystalline. 2. Using nanocoating for surface treatment of traditional products like glass, ceramic, textiles materials, wood, and PV cells. 3. Modifying the surface structures of conventional products to make them nanostructured. 4. Creating new Nanoporous material such as insulation materials.

In the energy sector: Nanotechnology can provide many benefits across the entire supply chain, from production to distribution (power transmission and heat transfer), storage like; Phase Change Materials.

3. Research Methodology

3.1. SCOPE AND LIMITATIONS

The case study is an office building located in Dokki area, Giza, in Cairo, Egypt. Thermal and energy performance are the key performance criteria. This paper focuses on the effect of Nanomaterials applied on the building envelope that could save more energy. The case study is a comparison between the energy consumption of an office building with and without using nanomaterials.

3.2. METHODS AND TOOLS

The Practical approach comprises two main activities: **First**, Analyzing the case study, measuring energy consumption and heat transfer through the building envelope by using traditional and Nanomaterials. **Second**, Comparing the conventional building envelope materials (base case model) with the Nano thermal models under typical Egyptian-Cairene weather conditions. Autodesk Revit is used to build up the model as it is very efficient, accurate and automatically updates floor plans, elevations, and sections. Design-Builder is used for the simulation process, The Design-Builder program has excellent features including rapid (building modeling, HVAC system built-up), easy to learn, perfect visualization effect and it is support from the ministry of energy of the United States. [Zhao et. al., 2017].

4. Base Case Parameters

The case study is Almoez tower [FIGURE 1], an office building in Cairo, Egypt. The base case parameters are shown in [TABLE 1], [TABLE 2].



Figure 1. The typical floor plan of the study building (left) and Tower sections (right) [http://www.almoez.com/]

TABLE 1. Areas of the tower sections

Total Section Area	The Area	Floors	Tower Sections
1801 m ²	335 m ²	Ground Floor	Comercial Section
	723 m ²	First Floor	
	723 m ²	Second Floor	
7114 m ²	153 m ²	Ground Floor	Administrative Section
	6498-722x9 m ²	9 Typical Floor	
	463 m ²	Roof	
1310 m ²	655 m ²	Basement 1	Car Parking
	655 m ²	Basement 2	
10225 m ²		Total Built up Area	

[<http://www.almoez.com/>]

THERMAL PERFORMANCE OF NANOMATERIALS OF A MEDIUM SIZE OFFICE BUILDING ENVELOPE

TABLE 2. The base case parameters

Office building main parameters	
Location	Giza, Egypt
Building area	655m ²
Occupancy schedules	8:30-3:30
Holidays	Friday & Saturday
No. of occupants	77 per floor
System description	
Electric supply	380V, 3Ph, 50Hz- 220V, 1Ph, 50Hz
Lighting For example, level 9	LED panels 60*60, LED spots R20 150 (4*18W) lighting fixture- 77(1*26W) spot lighting- 2 (2*36W) lighting fixture -7(exit sign)- 3(1KW) hand dryer.
For example, level 10	155(4*18W) lighting fixture- 91(1*26W) spot lighting 2(2*26W) lighting fixture -5 (exit sign) -3(1 KW) hand dryer.
HVAC	VRV HVAC systems - Average Cop:4.9 (heating) Average ERR:4.73 (cooling)
Winter set point	21-22 C
Summer set point	23-24 C
Total capacity	177 tons
Physical characteristics of the building	
Wall U-value for wall	250 mm brick (1.983 watts/m. sq...k)
Roof U-value for roof	-240 mm reinforced concrete slab -20 mm thermal insulation (blue polystyrene). -20 mm water insulation (BITUMODE Gamma) -100 mm inclined concrete slab (0.401 watts/ m ² . .k)
Floors	240 mm reinforced concrete slabs
Glazing All Windows U-value for the window Shading co-efficient Curtain wall U-value for curtain wall	curtain walls elevation (total length of facade 60.5m) single glazed/solar reflective glass 3 watts/ m ² C 0.811 Double glazing system, Color: blue, 2 layers of glass between them a layer of argon gas. 3.094 watts/ m ² k
Equipment used per one level	
83 PC (computers)	The unit load:0.8, Operation rate:100%, Total load per day:431.6 KW
8 Dryers	The unit load:1.6, Operation rate:60%, Total load per day:49.92 KW
8 Heaters	The unit load:2.4, Operation rate:70%, Total load per day:87.36 KW
2 Faxes	The unit load:0.4, Operation rate:70%, Total load per day:3.64 KW
3 LCDs	The unit load:0.4, Operation rate:100%, Total load per day:7.8 KW
2 Scanners	The unit load:0.4, Operation rate:60%, Total load per day:3.12 KW
3 Copiers	The unit load:0.8, Operation rate:80%, Total load per day:12.48 KW
13 Printers	The unit load:0.4, Operation rate:100%, Total load per day:33.8 KW

[Applied data is provided by the appointed planning consultant]

5. Validation Tests

The paper will focus on:

1. Glass (non-structural materials).
2. Effective insulation solutions: Vacuum Insulation Panels (VIPs).
3. Highly efficient thermal energy storage materials as Phase Change Materials (PCM).

5.1. SIMULATION FRAMEWORK

Energy simulations give architects some help in their design practice [Tian et al., 2018]. The variables that affect the simulation are the Physical characteristics of the building materials. [FIGURE 2] shows the simulation framework.

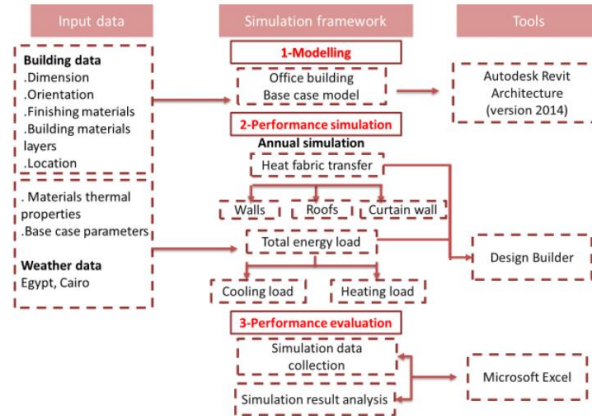

Figure 2. Main simulation process framework and supporting tools.

5.2. BASE CASE SIMULATION MODEL [A]

The input data used for the simulation of model [A] using traditional paint for walls, foam- polyurethane for roof insulation, and a double-glazing system with argon gas in between.

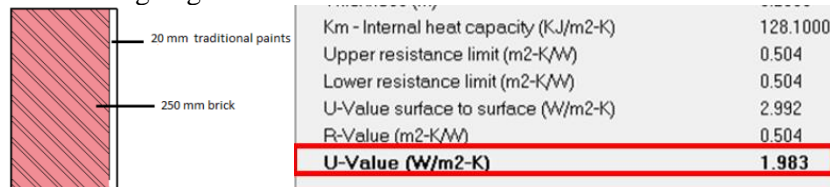

Figure 3. Exterior wall layers and input Simulation data for base case wall

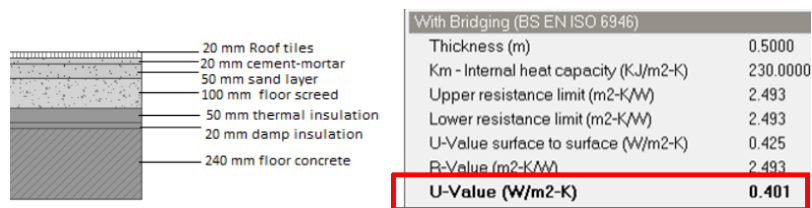

Figure 4. Roof layers and input Simulation data for base case roof.

THERMAL PERFORMANCE OF NANOMATERIALS OF A MEDIUM SIZE OFFICE BUILDING ENVELOPE

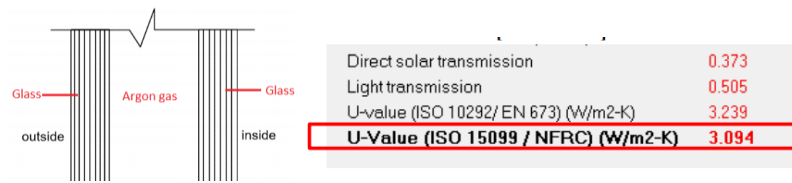

Figure 5. The double-layer glazing with Argon gas in between and input Simulation data for base case curtain wall.

From the simulation, the total energy consumption of the base case Model [A] (using traditional materials) is 2356328.89 Kwh = 235.94 Kwh/m², and Cooling load: 18837.58 wh/m².

5.3. UTILITY BILLS

The utility bills data in 2018 was used to standardize the base case of the existing building, which can be compared with similar buildings or with target values. The total energy consumption of the base case from utility bills is 247.7 Kwh/m². However, after using Design Builder simulation software the calculation is 235.94 Kwh/m², leading to a deviation gap of 5%.

5.4. NANO CASE SIMULATION

The following [Table 3] shows the different models used in the simulation.

TABLE 3. Thermal insulation models

Options	External wall	Roof	Curtain wall
Model A	Traditional paints	foam- polyurethane	double glazing
Model B	Nano paints	foam- polyurethane	double glazing
Model C	Traditional paints	Nano VIP	double glazing
Model D	Traditional paints	foam- polyurethane	Nano gel glazing
Model E	Nano paints	Nano VIP	double glazing
Model F	Nano paints	foam- polyurethane	Nanogel glazing
Model G	Traditional paints	Nano VIP	Nanogel glazing
Model H	Nano paints	Nano VIP	Nanogel glazing

5.4.1. Nano Model [B]: Exterior walls

The input data used for simulation of model B are shown in [FIGURE 6].

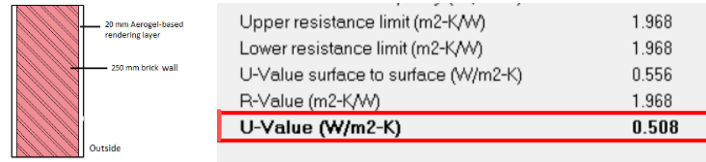

Figure 6. Exterior Nano wall layers and simulation input data for wall with Aerogel-based rendering of model B.

From the simulation: the total energy consumption is 234.01 Kwh/ m² and the Cooling load is 82557.04 wh/ m².

5.4.2. Nano Model [C]: Roof

The thermal resistance of VIP is about 10 times higher than the same thickness of conventional polystyrene (Bozsaky, 2016.).

The input data used for simulation of model C are shown in [FIGURE 7].

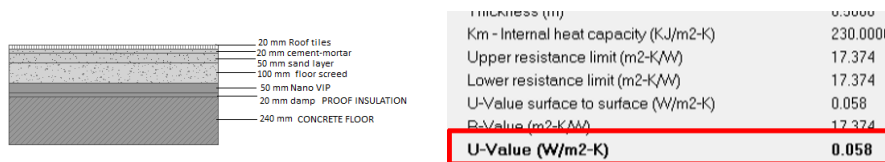

Figure 7. Nano Roof layers and Simulation input data for the roof with Nano VIP of model C.

From the simulation: the total energy consumption is 232.08 Kwh/ m² and the Cooling load is 87715.5 wh/ m².

5.4.3. Nano Model [D]: Curtain walls

The input data used for simulation of model D are shown in [FIGURE 8].

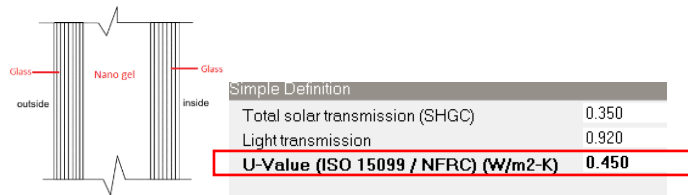

Figure 8. Nano Aerogel glazing two layers of glass-filled by Nano gel and Simulation input data for curtain wall with nanogel glazing of [model D].

From the simulation: the total energy consumption is 210.63 Kwh/m² and the Cooling load is 85006.25 wh/m².

THERMAL PERFORMANCE OF NANOMATERIALS OF A MEDIUM SIZE OFFICE BUILDING ENVELOPE

5.4.4. *Nano Model [E]: Aerogel plaster for external walls with Nano VIP for the roof.*

From the simulation: the total energy consumption is 230.69 Kwh/m² and the Cooling load is 88886.55 wh/m².

5.4.5. *Nano Model [F]: Aerogel-based rendering for external walls and nanogel glazing.*

From the simulation: the total energy consumption is 208.71 Kwh/m² and the Cooling load is 80095 wh/m².

5.4.6. *Nano Model [G]: Nano thermal insulation and nanogel glazing.*

From the simulation: the total energy consumption: 206.24 Kwh/ m² and the Cooling load is 81739.2 Wh/m².

5.4.7. *Nano case study Model [H]: Aerogel plaster for external walls with Nano VIP for roof and nanogel glazing.*

From the simulation: the total energy consumption is 204.22 Kwh/m² and the Cooling load: 75006.3 wh/m².

6. Discussion and Conclusions

6.1. MONTHLY VARIATION IN COOLING

Models [A], [B], [C], and [E] show higher consumption to cooling load compared with the other options and reduced by using Nano gel glazing in Models [D], [F], [G] and [H], in [Figure 9].

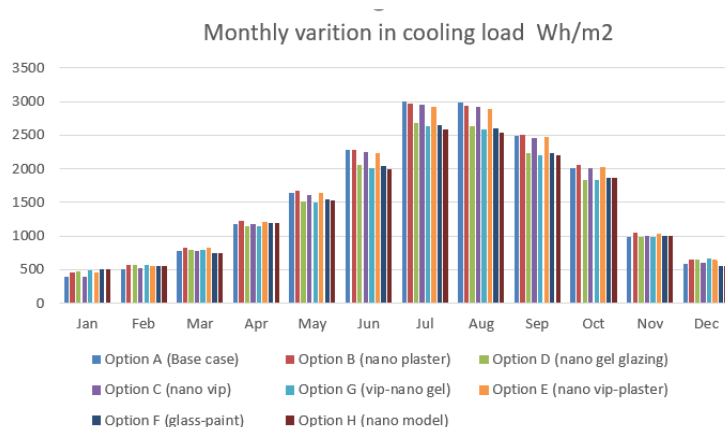

Figure 9. Monthly variation in cooling load.

6.2. THE ANNUAL ENERGY CONSUMPTION

In [Figure 10], it is noticed that models [B] and [C] save in annual energy consumption only 0.82% and 1.64% respectively, while model [D] saves about 10.7%.

In models [G] and [F], there is a saving in energy by 12.6% and 11.5% respectively, and in model [E] the saving is about 2.22% only.

The Model [H] makes a saving of 13.44% in annual energy consumption.

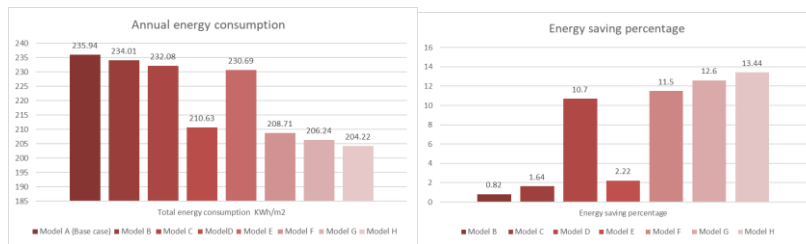

Figure 10. Annual energy consumption of various insulation models and Energy-saving percentages.

6.3. THERMAL TRANSMITTANCE COEFFICIENT

The study concludes that the U-value of Nano aerogel-based rendering caused an energy reduction by almost 3.9 times less than the traditional paint. Nano VIP caused an energy reduction by almost 7 times less than traditional insulating material and Nano gel glazing is caused an energy reduction by almost 7 times less than double glazing [FIGURE 11].

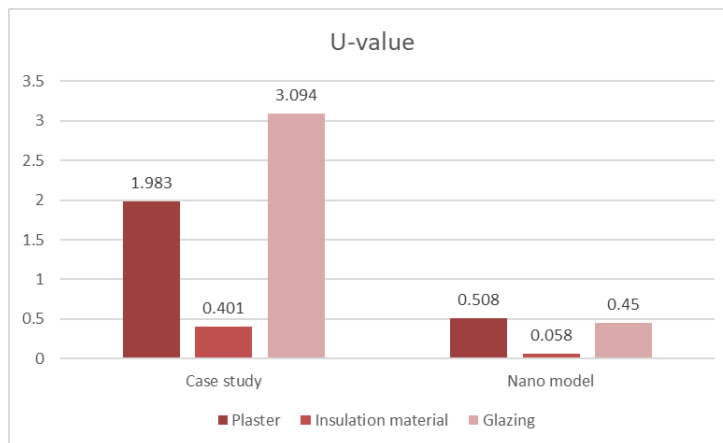

Figure 11. U-values

THERMAL PERFORMANCE OF NANOMATERIALS OF A MEDIUM SIZE OFFICE BUILDING ENVELOPE

6.4. THE HEAT TRANSFER THROUGH WALLS, ROOF, AND CURTAIN WALLS

The thermal performance of Nano aerogel-based rendering in walls reduces the heat exchange through the outer envelope in Models [B], [E], and [F] by 68.18%, 66.5%, and 62.7% respectively compared to model [A] [Figure 12a].

By using (VIP) in roof, the heat transfer was reduced by 82%, 81.5% and 81.4% in Models [C], [G], and [E] compared to model [A] [Figure 12b].

The heat exchange process through the Nanogel glass is reduced in models [D], model [G] and model [F] by 30.4%, and Model [H] by 33.7% [Figure 13].

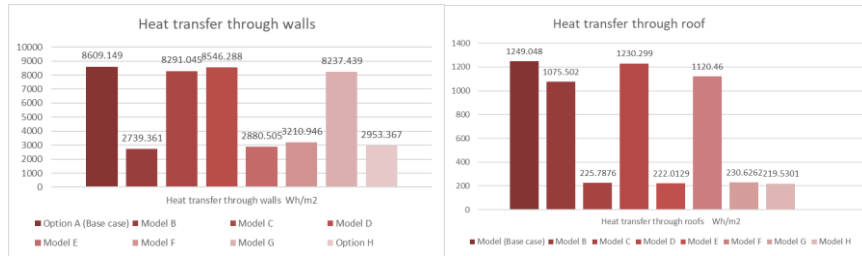

Figure 12a. Heat transfer through walls and b Heat transfer through roofs.

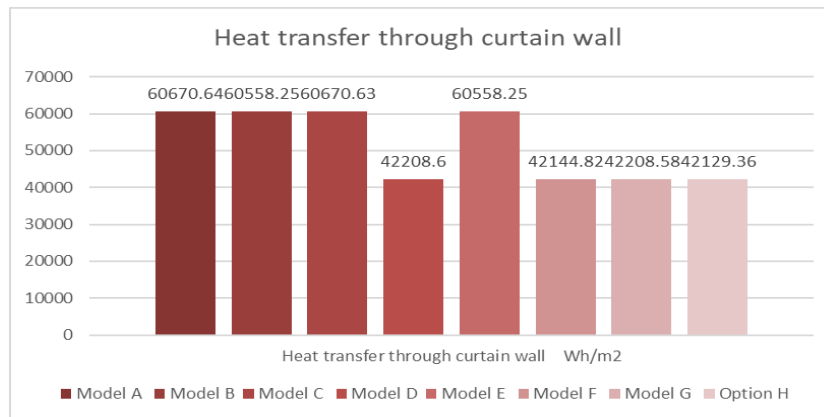

Figure 13. Heat transfer through the curtain wall.

Finally, by using nanomaterials we can reduce the cooling energy demand and total energy consumption of the building.

References

1. AKEIBER, H., NEJAT, P., MAJID, M. Z. A., WAHID, M. A., JOMEHZADEH, F., ZEYNALI FAMILI, I., ZAKI, S. A. 2016. A review on phase change material (PCM) for sustainable passive cooling in building envelopes. *Renewable and Sustainable Energy Reviews*, 60, pp.1470- 1497. doi: <https://doi.org/10.1016/j.rser.2016.03.036>.
2. ATWA, M. H., AI-KATTAN, A., EIWAN, A., 2015., Towards Nano Architecture: Nanomaterial in Architecture - A Review of Functions and Applications. *International Journal of Recent Scientific Research Vol. 6, Issue, 4*, pp.3551-3564, April 2015.
3. BOOSTANI, H., & MODIRROUSTA, S. 2016. Review of Nanocoating for Building Application. *Procedia Engineering*, 145, PP.1541-1548. doi: <https://doi.org/10.1016/j.proeng.2016.04.194>.
4. CASINI, M. 2016. 2 - Advanced materials for architecture. *Smart Buildings (pp. 55-104): Woodhead Publishing*.
5. CHUSS, M., PONT, U., MAHDAUI, A., 2017. "Long-term experimental performance evaluation of aerogel insulation plaster. *Energy Procedia 132: pp.508-513*
6. CUI, Y., XIE, J., LIU, J., & PAN, S. 2015. Review of Phase Change Materials Integrated in Building Walls for Energy Saving. *Procedia Engineering*, 121, pp.763-770. doi: <https://doi.org/10.1016/j.proeng.2015.09.027>
7. MOHAMED, A. S. Y. 2015. Nano-Innovation in Construction, A New Era of Sustainability. *International Conference on Environment and Civil Engineering (ICEACE'2015) 20*.
8. ROBATI, M., KOKOGIANNAKIS, G., & MCCARTHY, T. J. (2017). Impact of structural design solutions on the energy and thermal performance of an Australian office building. *Building and Environment*, 124, pp.258-282. doi: [10.1016/j.building.2017.08.018](https://doi.org/10.1016/j.building.2017.08.018)
9. TIAN, Z., ZHANG, X., JIN, X., ZHOU, X., SI, B., & SHI, X. 2018. Towards adoption of building energy simulation and optimization for passive building design: A survey and a review. *Energy and Buildings*, 158, pp.1306-1316. doi: [10.1016/j.enbuild.2017.11.022](https://doi.org/10.1016/j.enbuild.2017.11.022)
10. ZHAO, D., FAN, H., PAN, L., XU, Q., & ZHANG, X. (2017). Energy Consumption Performance Considering Climate Change in Office Building. *Procedia Engineering*, 205, pp.3448- 3455. doi: <https://doi.org/10.1016/j.proeng.2017.09.868>

ON THE INFLUENCE OF EVOLUTIONARY ALGORITHM (EA) OPTIMIZATION IN ARCHITECTURAL DESIGN

A reflection through an architectural envelope's shadowing system design

GIUSEPPE CANESTRINO

Department of Civil Engineering, University of Calabria

Email address:

giuseppe.canestrino@unical.it, giuseppe.canestrino@gmail.com

Abstract. Evolutionary Algorithm (EA) are optimization techniques that can improve measurable performances of a design. Currently, they see many research interests and are advertised, among generative design, as the next big thing in architecture by some software house. However, they still see limited professional use. This paper, through the analysis of past researches and a case study on an architectural envelope's shadowing system design, reflects on the reasons for this and on how the use of EA influences the product and the process of architectural design. Also, methodological principles to suit the use of EA in an architectural design process are discussed.

Keywords: *Architectural design; CAAD; EMOA; parametric architecture; performance driven design, Parametric design*

ملخص. (EA) المعروفة بالخوارزمية التطورية هي تقنية تحسين يمكنها تطوير آليات قياس التصميم. فعلى الرغم من عدم استخدامها مهنيًا بصورة كبيرة، إلا أن العديد من شركات البرمجة لديها اهتمامات بحثية بتلك التقنية التي يتم تسويقها على أنها الحدث الكبير القادم في مجال الهندسة المعمارية. ويعكس هذا البحث أسباب ذلك وكيفية تأثير استخدام (EA) الخوارزمية التطورية على المنتج وعلى عملية التصميم المعماري. وذلك من خلال تحليل الأبحاث السابقة ودراسة حالة لتصميم "نظام تظليل لمبنى مغلف معماريًا" مع مناقشة المبادئ المنهجية الموائمة لاستخدام (EA) الخوارزمية التطورية في عملية التصميم المعماري.

الكلمات المفتاحية: *التصميم المعماري ; EMOA ; CAAD ; العمارة القياسية ; التصميم القياسي ; التصميم المدفوع بالأداء.*

1. Introduction

This paper acknowledges EA as a potentially powerful tool in design and reflects on how its use influences in particular architectural design. A mismatch on how *designers design* and their expectation for an EA framework is recognized. Many researches are interested in developing the technology while there is a lack of methodological guidance to make these tools useful in actual architectural design. Therefore, tools and methods that need to be developed to fit this technology into an actual architectural design unfolding process are discussed. The development of a methodological theory for the use of EA may be delayed in the conviction that further developments in the technology will make it unnecessary. However, in this way we are in danger of wasting an opportunity for Architectural Design.

2. On the evolutionary metaphor in architectural design

Designing with an evolutionary metaphor involves using methods inspired by evolutionary processes in nature. This inspiration does not concerns the formal aspects of architecture but is about the unfolding of the form and nature's ability to produce form and design in balance with respects to external environmental constraints. This unfolding is closely related to improving one or more (measurable) performances of a design. Some of the available tools and procedure to perform these task are Genetic Algorithm, Hill Climbing, Simulated Annealing, Artificial Neural Network and others. Genetic Algorithm, also known as Evolutionary Algorithms, has seen a lot of interest in research and their development is strictly linked to the translation into computational logic of Darwin's evolution theory. Crucial to using a genetic algorithm is having a method capable of producing a consistent number of architectural outputs, therefore today they see use for exploring the design space of a parametric algorithm. In Tedeschi's (2014) schematization of parametric design, an Evolutionary Algorithm can be used to reiterate *N-Times* a set of instruction exploring the design space on a performative base. Available Evolutionary Algorithms share common traits. A common framework consists in populating the design space with random solution and then applying a loop: (1) evaluation of these solutions, (2) selection of the most promising solutions, (3) hybridization of the most promising solutions (4) generation of new and fitter population and repetition until requirements are meet (i.e. constant hypervolume or maximum number of prescribed generation reached).

The application of Evolutionary Algorithms in architectural design ensure to pick one of the best solution producible by a generative procedure. However, at the end of the application of an Evolutionary Algorithm, the designer could

ON THE INFLUENCE OF EVOLUTIONARY ALGORITHM (EA) OPTIMIZATION IN ARCHITECTURAL DESIGN.

be overwhelmed by a decision making process much harder than exploring the design space without an Evolutionary Algorithm (Davis, 2020): choosing from 10 possible optimized design may be far more difficult than choosing from 20 possible unoptimized design.

The author, therefore, identifies in the final decision making the principal problem in the use of EA in architectural design and that it might produce a cognitive impairment when “*the advantages of diversity and individualization are cancelled by the complexity*” (Alvin, 1970) of decision making-process: the theory of *overchoice* was curiously developed in the same years of the first Evolutionary Techniques development. Another important aspect is that not every design process is suitable to be optimized with EA for two principal reasons: the design space related to the process is not explorable on a performative basis (i.e. uses random number generation) and the time to produce and evaluate a single solution makes the use of EA inconvenient.

An interest of architectural critics is how a design methodology influences the design process and output. An interesting position (Purini, 2018) address the exaltation of technical aspects of architecture, as done with a framework based on the use of EA, as *neofunzionalismo* (neo-functionalism). The risk of this vision is to automatically consider an optimized design as a quality architecture . A change in our vision of the so-called “*algorithmic neutrality*” will be a future challenge. The author identifies in a framework based on EA an unneutral architectural design method, as it implicitly pushes the designer to certain kind of thought and output. This is not an aspect to be stigmatized, but to be aware of it. One of the most lucid translation in architectural design of the quote “*We shape our tools and thereafter our tools shape us*” is found in Zevi (1973): trying, with all the respects that the Italian critic deserves, to translate his thought we may say that an EA based framework pushes the designer to think in terms of explorable design space and fitness functions instead of in terms of Architecture and built space. From these aspects comes the need to look at the use EA as a *material*, as intended for Gregotti (2018), that forms architecture, as well as physical material or the economical and social relations that lie behind an architectural design.

3. Background and promising horizons

Unlike BIM, or even parametric modelling to which EA is very congenial, optimization techniques are methods that we do not find in most architectural firm toolset. Some early uses of EA in architecture are discussed among with contemporary promising applications and thoughts. The selection of scientific products and researches aims to speculate on why apparently so powerful tools

struggle to active a true transfer of knowledge towards professional use and how they influence the architectural design process.

3.1. ROOTS AND EARLY USE OF EA IN ARCHITECTURE

The first application of an evolutionary approach in architecture proposes a framework not sustainable by the majority of today's architectural firm. In his groundbreaking research, Frazer (1995) had to develop his own computer software, computer language and even to prototype his own computer hardware. He recognized that an Evolutionary Algorithm is an optimization technique proven successful with well-defined problems and criteria to be fulfilled. Evolutionary Algorithm, or Genetic Algorithm, was classified as Evolutionary Techniques together with *Adaptive Models*, *Biomorph*, *Classifier System* and *Conflicting Criteria*. However, Frazer recognized a particular excitement of the scientific community about some abilities of Evolutionary Algorithm: the production of unthought solution among with the ability to chew bad problem setting was in 1995 as today the most interesting characteristic of Genetic Algorithm. The reptile system (Frazer, 1974) forced to work with an abstraction of an architectural problem due to software and hardware limitations. This translates into producing *coded spatial units* that can reproduce the characteristic aspects of a design using a minimum computational effort.

Frazer's research was culturally influenced and tries to give practical answer and applications to the work of Negroponte and Pask. The first clearly state on his *Soft Architecture Machine* (Negroponte, 1975) that he searched questions among answers. He recognized that if a class of machines exhibit intelligent behaviour then they could aid the development and evolution of architecture and that these machines should have the ability to evolve in time (learn how to explore the design space on a performative base). Pask (1969) contributes to the evolution of computational thinking in architectural design with his push to calculate, determine and predict different aspects of architecture (environmental, social, cultural).

3.2. PROMISING HORIZONS

An interesting interview of 18 architects and designer found that a computed optimum solution is often used as a starting point for design exploration (Bradner, Ioro, & Davis, 2014). With this mindset, a set of high performing design given by the EA is as important as the single fitter solution. Another important aspect is the common belief that available user interface for the use of EA and design space exploration produce a poor user experience (ibid., 2014). Hence the importance to develop new methods that make the tool fit the process and not vice versa. *Dream Lens* (Matejka, et al., 2018) is a visual

ON THE INFLUENCE OF EVOLUTIONARY ALGORITHM (EA) OPTIMIZATION IN ARCHITECTURAL DESIGN.

analysis tool for exploring large generative design dataset facilitating the decision making processes. The proposed system was developed to highlight both appearance and properties of each design among encouraging design space exploration. Novel features like *multi-attribute grid* or *model stacking* helps the designer to understand emergent properties of its generative systems. *GEM-NI* (Zaman, et al., 2015) is a system developed to support parallel exploration of alternative design with interesting features such as *parallel editing*, *recalling history*, *branching*, and *merging* for and of design alternatives. These features may reproduce strategies used in design, such as *design hysteresis*: discovering design alternatives through recombination of different designs.

A lack of interaction and possibility of comparison, generation and multiplication of multiple parametric designs for Mohiuddin and Woodbury characterize existent tools (2020). They propose novel types of interactions in parametric design that may lead to a better use of EA: *parallel editing*, *sketching*, *automated generation*. An EA based framework can also be used among with traditional design methods (Canestrino, Greco, Spada, & Lucente, 2020)

These promising researches don't aim only to enhance a technology but to fit an existent technology into a real process of design.

4. A reflection through an architectural envelope's shadowing system design.

The case study briefly described in this paper is developed to exemplify some thoughts on the use of EA in architectural design. The aim is to identify methodological principles for the use of EA in architectural design.

The application concerns the design of an architectural façade's shadowing system optimized with EA: this is an application proposed in a plateau of other research that however are more interested in technical results rather than the implication in architectural design as discipline and profession.

4.1 PROBLEM SETTING

The case study concerns the design of a 20m x 6m south-facing façade in a Mediterranean climate (Rome). The shadowing system consist of a wooden cladding to be made with a CNC cutting machine and to be designed with a generative algorithm written in Grasshopper (Rhinceros).

A method to reduce the explorable design space and to ease decision making is applied. Before the visual programming phase, a rude model of the façade is modelled in BIM (Archicad21) and then imported to Grasshopper: this step

facilitates the creation of the IFC primitives that are generated at the end of the selection phase. Three fitness function are developed:

1. Area of the shadowing system [to minimize, m²]
2. Total radiation on the architectural envelope from 1 November to 15 April. [to maximize, kWh]
3. Total radiation on the architectural envelope from 16 May to 30 September. [to minimize, kWh]

The time periods considered in the fitness functions reflect the requirements of the Italian legislation for the city of Rome with respect to the obligation to heat or cool a building. The generative algorithm produces a minimum coded configuration to ease the calculation of the fitness function among with an IFC model of the output. The software suite is completed with the plugins Wallacei (EA solver) and Ladybug (radiation calculation).

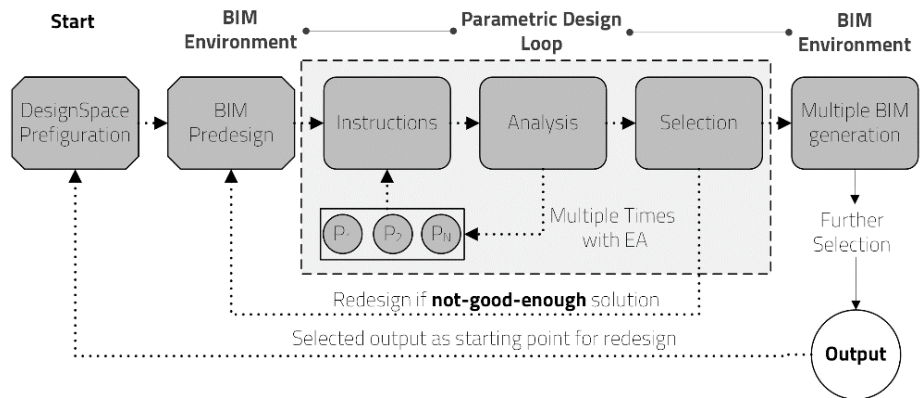

Figure 1. Methodological framework.

4.2 PROPOSED METHOD

The proposed workflow aims to reduce *overchoice* in the designer and to fit the use of EA in an architectural design process. It is based on a qualitative prefiguration of the design space. A typical EA framework output may consist of hundreds of solutions proposed to the designer whose duty is to evaluate all of them and pick the best. As said by Davis (2020) designer from architecture and other fields does not work like this.

The author suggest to overshadow that EA can produce unexpected solution. Instead, EA could produce solutions within an already validated design space. This assures that an evaluation of unquantifiable aspects of architecture has been done before the use of EA the subsequent decision making.

The control of the explorable design is a fundament of architectural design and different methodological approaches guarantee it. In this paper, the *listing as design methodology* by Zevi (1973) has been applied. For the Italian critic,

ON THE INFLUENCE OF EVOLUTIONARY ALGORITHM (EA)
OPTIMIZATION IN ARCHITECTURAL DESIGN.

the listing “*demands a new beginning, as if no linguistic system had ever existed before, as if it were the first time in history that we had to build a house or a city*”. This approach fit perfectly the need to construct algorithms and procedure from scratch as showed by Frazer (1995).

Given some design constraint (20m x 6m façade to be screened) several sun screening strategies are listed. For some promising strategies, different prefiguration of the sunscreens are then listed.

A design often can be reproduced with different generative strategies. And a generative strategy can reproduce different designs. Qualitatively, these generative strategies and their relations are mapped. Only generative strategy that reproduce promising design or group of designs that are more likely to give positive outputs are coded and processed with EA.

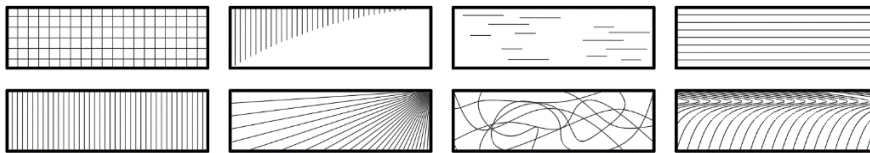

Figure 2. Examples of possible design strategies.

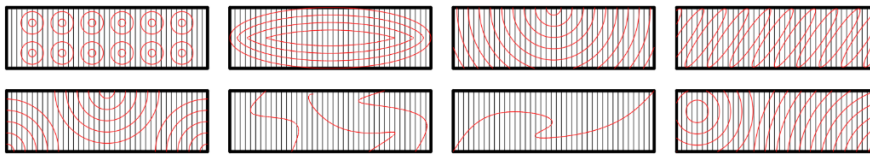

Figure 3. Examples of possible differentiation of a design strategies.

The proposed methodology is not linear: in architectural design, in each step, the possibility to go back and alter decisions must be left. The generative algorithm should be written not to reproduce all of the solution prefigured, but instead just a few solutions that ensure quality architecture. This guarantees an important reduction of the explorable design space. A strategy able to reproduce a promising group of design is chosen.

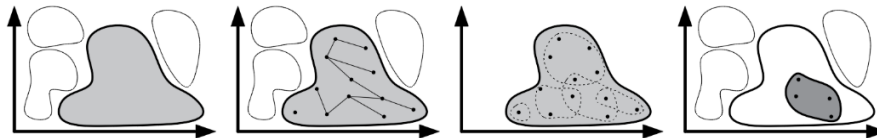

Figure 4. Progressive reducing of the design space to explore with a generative algorithm.

The parameters involved in the generation of the architectural façade system regard a position of a point in the space, the period of a sin function, the number of vertical slabs and their depth.

5. Results

With the Plugin Wallacei the NSGA-2 algorithm is employed for 100 generation with 50 individuals each. This led to a simulation runtime of 5h and 30 minutes. The consideration of EA in architectural design as a starting point for design exploration lead to use a K-Means algorithm to generate 8 cluster of the solution on the Pareto front. The number of clusters to generate should be as high as much significantly different design strategy or cluster the algorithm can produce (Canestrino, 2020b).

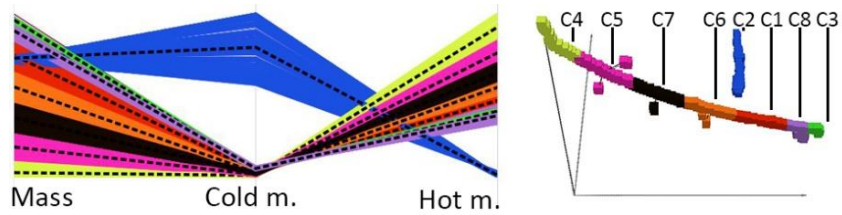

Figure 5. Clusters on the Parallel Coordinate Plot (better fitness functions have lower coordinate) and the fitness space.

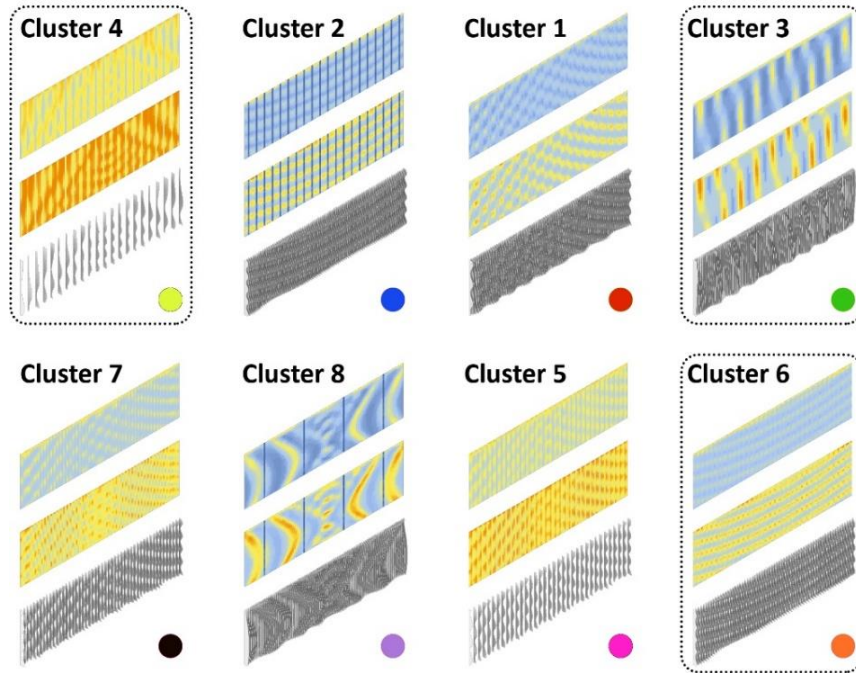

Figure 6. Representative phenotype of each cluster (in grey). The middle colourmap for each phenotype gives information on the radiation in cold months, the other one on the radiation in hot months.

The proposed framework allowed to choose 3 solution: a solution that uses significantly less mass (Cluster 4), a balanced solution (Cluster 6) and an

ON THE INFLUENCE OF EVOLUTIONARY ALGORITHM (EA) OPTIMIZATION IN ARCHITECTURAL DESIGN.

aesthetically pleasant solution (Cluster 3). These solutions can be implemented in a BIM software for further decision making; the conversion in IFC is made easy and automated by the methodology proposed.

6. Discussion/conclusion

The need to abstract architectural design, as done by Frazer, still characterizes today's use of evolutionary algorithm because the complexity of the analysis doable are growing together with the increasing computational power available. Hence an important change in the attitude of the designer that must obtain a deeper understanding of his design unfolding to maximise the utility genetic algorithms. Not all strategies for solving an architectural problem are suitable to be abstracted, to generate an explorable design space or to be evaluated. If the use of EA is seen as a goal to pursue to give scientific rigour to a project we can state that this tool is not neutral as is not suitable for different types of forms and procedures. From the conception of EA techniques as *materials* that influence the architectural design process comes awareness that while opening up to the possibility of optimizing a project, various formal possibilities are necessarily left behind. Different contemporary promising applications for the development of the use of EA in architectural design was presented. These researches share the aim to help the designer instead of designing for him. A shift from *Evolutionary Design* to *Evolutionary Aided Design* might affect common day to day architectural design only by working both on available methodologies and tools.

The author acknowledges that designers might place too high expectations on EAs when applied to architectural design. Changing the expectations we have from EA may transform them in more useful tool. The belief that soon robust automated decision-making procedure will harvest ideal design coming out from an EA is delaying the development of design methodologies able to manage an EA framework. These methodologies might translate indications already given by architectural theorists, as done in this paper with Zevi's idea of *listing as design methodology* and Gregotti's idea of *architectural material*, to the actual practice of architectural and computational design. Future works that enrich these thoughts with contemporary work on design space representation and exploration (Woodbury, 2010; Woodbury & Burrow, 2006) may make EA more suitable for an architectural design unfolding.

Architects who don't use EA, although they still do design space exploration, don't have the illusion to manage too much variability in a project. Reducing the explorable design space, as done in this paper, may lend to a more manageable decision making. The greater the effort involved designing the variability of our project/algorithms, the lower the possibility of *overchoice*

or decision fatigue. In architectural design using EA as a scientific tool may lead to optimized solutions in measurable aspects but this does not ensure quality architecture (Canestrino, 2020a). The shift from *EA as an optimization tool* to *EA as a design tool* might overcome this flaw.

References

- ALVIN, T., 1970. *Future Shock*. New York: Random House.
- BRADNER, E., IORO, F., & DAVIS, M., 2014. Parameters Tell the Design Story: Ideation and Abstraction in Design Optimization. In *Proceedings of the Symposium on Simulation for Architecture & Urban Design (SimAUD '14)*. San Diego: ACM.
- CANESTRINO, G., 2020a. On the use of BIM and parametric modelling for building design: implications and risks on the quality of architecture. Presented at *Connections: exploring heritage, architecture, cities, art, media*. In *AMPS Proceeding Series*. Liverpool: AMPS.
- CANESTRINO, G., 2020b. Use of parametric approach for user-oriented development in building design: preliminary investigations. In *Urban and Transit Planning - Edition 2: Towards Liveable Communities: Urban places and Design Spaces*. Presented at Urban Planning & Architectural Design for Sustainable Development – 5th Edition. Cham: Springer.
- CANESTRINO, G., GRECO, L., SPADA, F., & LUCENTE, R., 2020. Generating architectural plan with evolutionary multiobjective optimization algorithms: a benchmark case with an existent construction system. In *Proceeding of the XXIV International Conference of the Iberoamerican Society of Digital Graphics - SiGraDi2020*.
- DAVIS, D., 2020. *Generative Design is Doomed to Fail*. Retrieved October 2020, from <https://www.danieldavis.com/generative-design-doomed-to-fail/>
- FRAZER, J., 1974. Reptiles. *Architectural Design*.
- FRAZER, J., 1995. *An evolutionary Architecture*. London: Architectural Association.
- GREGOTTI, V. 2018. *I racconti del progetto (trad. Tales of the design)*. Milano: Skira.
- MATEJKA, J., GLUECK, M., BRADNER, E., HASHEMI, A., GROSSMAN, T., & FITZMAURICE, G., 2018. Dream Lens: Exploration and Visualization of Large-Scale Generative Design Datasets. In *CHI '18: Proceedings of the 2018 CHI Conference on Human Factors in Computing Systems* (pp. 1-12). Montreal: ACM
- MOHIUDDIN, A., & WOODBURY, R., 2020. Interactive Parallel Coordinates for Parametric Design Space Exploration. In *Conference on Human Factors in Computing Systems* . Honolulu: ACM.
- NEGROPONTE, N., 1975. *Soft Architecture Machines*. Cambridge: MIT Press.
- PASK, G., 1969. The architectural relevance of cybernetics. *Architectural Design*.
- PURINI, F., 2018. Il BIM. Un parere in evoluzione (trad. BIM: BIM. An evolving opinion) . *Op.cit. Selezione della critica d'arte contemporanea (trad. Op.cit.: selection of contemporary art critic)*.
- TEDESCHI, A., 2014. *AAD_Algorithms-Aided Design*. Napoli: Edizioni Le Pensur.
- WOODBURY, R., 2010. Design Space Exploration. In R. Woodbury, *Elements of parametric Design*. Oxon: Routledge.
- WOODBURY, R., & BURROW, A., 2006. Whither design space?. In *Artificial Intelligence for Engineering Design, Analysis and Manufacturing*, 63-82.
- ZAMAN, L., STUERZLINGER, W., NEUGEBAUER, C., WOODBURY, R., ELKHALDI, M., SHIREEN, N., & TERRY, M., 2015. GEM-NI: A system for creating and managing alternatives in generative design. In *CHI '15: Proceedings of the 33rd Annual ACM Conference on Human Factors in Computing Systems* (pp. 1202-1210). Seoul: ACM.
- ZEVI, B., 1973. *Il linguaggio moderno dell'architettura. Guida al codice anticlassico (trad.: The modern language of architecture)*. Torino:Einaudi

EELISH: GRASSHOPPER PLUGIN FOR AUTOMATED COLUMN-BEAM PLACEMENT ON ORTHOGONAL FLOOR PLANS

Formalising manual workflow into an algorithm through empirical analysis

JOY MONDAL
WEsearch lab, Delhi, India
Email address: joy@weseearchlab.com

Abstract. The implicitly parametric if-else logic of determining column-beam locations is applied manually on virtually every orthogonal design, thereby inflating workhours and cost through unnecessary repetition of labour. This paper presents the development of a generative algorithm (released as Grasshopper plugin Eelish) which automates the placement of column centre points and beam centre lines on orthogonal floor plans with the aim of maximising regular ceiling division. The manual process of column-beam placement is formalised as the algorithm through empirical analysis of layouts drawn by architects. Regular ceiling division is maximised in a concave room by calculating column-beam grid of the largest rectangle inscribable in the room, and then extending the grid to the entire room. The placements are guided by the maximum and minimum allowed spans of slabs, and the maximum allowed span of cantilever slabs. The generated layouts have a qualitative 'Satisfactory' or better approval rating of 93.5% by architects and 83.6% by structural engineers.

Keywords: Column; beam; orthogonal; floor plan; ceiling; automated.

ملخص. يتم تطبيق المنطق البارامترى الضمني لتحديد مواقع شعاع العمود يدويًا على كل تصميم متعامد تقريبًا ، وبالتالي تضخيم ساعات العمل والتكلفة من خلال التكرار غير الضروري للعمال. يقدم هذا البحث تطوير خوارزمية توليدية (تم إصدارها باسم Grasshopper plugin Eelish) والتي تقوم بأتمتة وضع نقاط مركز العمود وخطوط مركز الحزمة على مخططات الأرضيات المتعامدة بهدف تعظيم تقسيم السقف المنتظم. يتم إضفاء الطابع الرسمي على العملية اليدوية لوضع شعاع العمود كخوارزمية من خلال التحليل التجريبي للتخطيطات التي رسمها المهندسون المعماريون. يتم تكبير تقسيم السقف المنتظم في غرفة مقعرة عن طريق حساب شبكة شعاع العمود لأكبر مستطيل يمكن تدوينه في الغرفة ، ثم توسيع الشبكة إلى الغرفة بأكملها. تسترشد المواضع بالحد الأقصى والأدنى المسموح به من الألواح ، والحد الأقصى المسموح به من ألواح الكابولي. التصميمات التي

تم إنشاؤها لها تصنيف موافقة نوعي "مرض" أو أفضل بنسبة 93.5٪ من قبل المهندسين المعماريين و 83.6٪ من قبل المهندسين الإنشائيين.

الكلمات المفتاحية: عمود، كمرّة، تعامد، المسقط الأفقي، الأسقف، الأتمتة.

1. Introduction

Architects typically invest substantial amount of workhours to determine the location of columns and beams on floor plans of framed structures before the fuzzy layouts are sent to the structural consultant for calculation of column, beam and slab dimensions and specifications. In the case of orthogonal designs, the process of column-beam placement usually comprises of two sequential steps. Firstly, columns are placed on plan by manual execution of a set of soft if-else logic that is guided by informal rules of thumb (Benzu, 2011). The placement of columns in turn determines the placement of beams (Herr and Fischer, 2013). Different toolkits and software have been developed over time to rapidly model column and beam layouts. But these solutions require explicit modelling overlaid on and guided by floor plans. The software do not prompt automatic suggestion of column-beam placement. Consequently, the soft if-else logic is repeatedly applied manually from scratch on virtually every orthogonal design. The need of the hour is to develop an algorithm which automatically applies the inherently parametric soft if-else logic of column-beam placement on conceptual plans.

This paper presents the development of such an algorithm. The algorithm places column centre points and beam centre lines on orthogonal floor plans of convex and/or concave rooms, with the aim of maximising regular ceiling division. It is conceived by formalising the sequential workflow of the manually executed column-beam placement layouts. The algorithm was investigated using custom C# scripts on Grasshopper and has been subsequently released as a free plugin named Eelish. The following sections elaborate the objectives, the empirical analysis of the manual process, its formalisation into an algorithm, the components of Eelish, and qualitative review of the generated layouts.

2. Background

2.1. RELATED WORK

Structural consultants typically calculate the dimensions and specifications of columns, beams and slabs of the layouts made by architects according to the local structural codes. Based on the quantitative and tacit knowledge of decades of calculations, structural engineers have derived rules of thumb for

EELISH: GRASSHOPPER PLUGIN FOR AUTOMATED COLUMN-BEAM PLACEMENT ON ORTHOGONAL FLOOR PLANS

run-of-the-mill buildings of regular orthogonal geometry (Rajapakse, 2016). Software (like STAAD) is typically used for calculations of either designs of irregular geometries, or challenging long spans; or for projects of elevated importance, or budget. Such structural calculations have been attempted to be automated by using evolutionary algorithm (Nimtawat and Nanakorn, 2009), adjacency graph (Shaw, Miles, and Gray, 2008), and parametric rules of thumb (Sacks, Warszawski and Kirsch, 2000). These research typically need to be given a column-beam placement layout, which is subsequently used as the canvas for executing the calculations.

Architects, on the other hand, have tried to adapt the notations used by structural engineers for better collaboration. Herr and Fischer (2014) have developed a toolkit to model column-beam layouts for RCC structures. To generate layouts, users need to learn and manually overlay notational graphs on plans, making the process semi-automatic. Mondal (2018) has formalised the manual process of repeated sub-division of a room to place column-beam on convex orthogonal plans. The research does not address concave rooms. However, this research borrows the idea of using the rigour of empirical analysis to formalise a manual process that has clear objectives, but ill-articulated process.

2.2. COLUMN-BEAM PLACEMENT

Column-beam placements on orthogonal plans can be broadly categorised into two types as follows:

- *Grid driven*: Typically uses one global grid system or a combination of a few smaller grid systems to overlay column-beam on plans that are also often designed using the pre-determined grid system(s). Since grids are dependent on the position of walls of neighbouring rooms, if a room is larger than the maximum allowed span, columns added inside the room may not divide the room equally.
- *Ceiling division driven*: Typically lays down equidistant beams and columns in rooms to achieve regular ceiling divisions. Consequently, if a room is larger than the maximum allowed span, columns added inside the room divide the room equally.

Eelish formalises the column-beam placement process of the latter kind. Ceiling division driven placements are preferred for their aesthetic sensitivity towards dividing a space equidistantly by beams. Additionally, since columns are also added equidistantly, the latter process is suitable for designs with rooms larger than the maximum allowed span of slab.

2.3. OBJECTIVES AND VARIABLES

The primary objectives of the algorithm are twofold as following:

- To place columns and beams such that all the slabs are within predefined maximum and minimum allowed spans, and
- To maximise regular ceiling division, or in other words, minimise irregular ceiling divisions.

The column-beam placement simulation is controlled by four inputs or variables mentioned as following:

- The floor plan,
- Maximum allowed span of slab (*MaxS*),
- Minimum allowed span of slab (*MinS*), and
- Maximum allowed span of cantilevered slab (*CanS*).

3. Empirical Analysis of the Manual Process

The manual process of column-beam placement is documented and empirically analysed to extract and formalise the soft if-else logic into an algorithm.

3.1. DATA FOR ANALYSIS

Ten architects, each having professional experience of at least 5 years, were asked to place columns and beams on four orthogonal plans. Two plans had a combination of convex and concave rooms. The other two plans had only convex rooms and only concave rooms, respectively. The architects were asked to make the layouts while satisfying the objectives mentioned in section 2.3. Each architect was given three sets of *MaxS*, *MinS* and *CanS* (3.0m, 1.5m and 1.5m; 4.5m, 2.2m and 2.2m; and 6.0m, 3.0m and 3.0 m). Each architect was asked to make three layouts per plan using the three sets of distances. Thus, each architect made twelve layouts, amounting to a total of 120 layouts in the analysis. All the steps involved in making the 120 layouts, i.e., the placement of any column centre point or beam centre line, were digitally documented.

3.2. OBSERVATIONS

Subsequently, the 120 layouts and the steps to make the layouts were analysed to extract takeaways for conceiving the algorithm. The observations are as following –

- In 81% of the layouts, placement started from the largest room,
- In 61% of the layouts, placement concluded at the smallest room,

EELISH: GRASSHOPPER PLUGIN FOR AUTOMATED COLUMN-BEAM PLACEMENT ON ORTHOGONAL FLOOR PLANS

- When convex and concave rooms have the same area, in 93% of the cases, convex rooms were addressed before concave rooms,
- In the case of convex rooms, in 67% of the instances, orthogonal grids were laid by simply dividing the length and the width by $MaxS$,
- In the case of concave rooms, in 47% of the instances, the rooms were sub-divided into convex parts before proceeding with the placement, and
- 14% of the layouts did not conform to the objectives.

3.3. TAKEAWAYS FOR THE ALGORITHM

The findings demonstrate that more importance is given to larger spaces compared to smaller spaces. Convex rooms are given precedence over concave rooms of the same area, possibly due to higher isoperimetric quotient of convex rooms (Croft, Falconer and Guy, 1991). In the case of convex rooms, column-beam can be placed on a grid generated by the divisions of length and width by $MaxS$. However, in the case of concave rooms, the takeaway of sub-division into convex parts is indicative and not conclusive.

4. Concave Room Irregularity

Concave rooms typically have a combination of equidistant regular ceiling divisions ($S(eq)$) and non-equidistant irregular ceiling divisions ($S(irr)$). Concave rooms can have 100% $S(eq)$ (and consequently get rid of $S(irr)$) only in one scenario – when the length and the width fragments of the room are such that the highest common factors of the lengths of all the length and the width fragments, respectively, are within $MaxS$ and $MinS$. In all the other scenarios, concave rooms are bound to have $S(irr)$ portions in the ceiling.

To engineer a methodology of minimising $S(irr)$, different types of divisions (or possible grids) of 30 concave rooms were studied. The aim of the study was to find out the division type that yields lowest $S(irr)$ to $S(eq)$ ratio on a consistent basis. Orthogonal grids ($Gr(rec)$) were overlaid on rooms by adding gridlines on all the walls, as shown in Figure 1a. Using three-point combinations of all the points of self-intersections of $Gr(rec)$ ($Pt(rec)$), an exhaustive list of divisions were conceived. Subsequently, the $S(irr)$ to $S(eq)$ ratio of all the divisions were tabulated. As illustrated in the few examples of Figure 1a, concave rooms have been found to have the lowest $S(irr)$ to $S(eq)$ ratio when division is made based on three-points corresponding to the largest inscribable rectangle ($R(rec)$). In other words, $S(eq)$ is maximised when the division of $R(rec)$ is extended to the entire

room (Figure 1b). Since $R(rec)$ is convex, its division can be calculated by dividing length and width by $MaxS$.

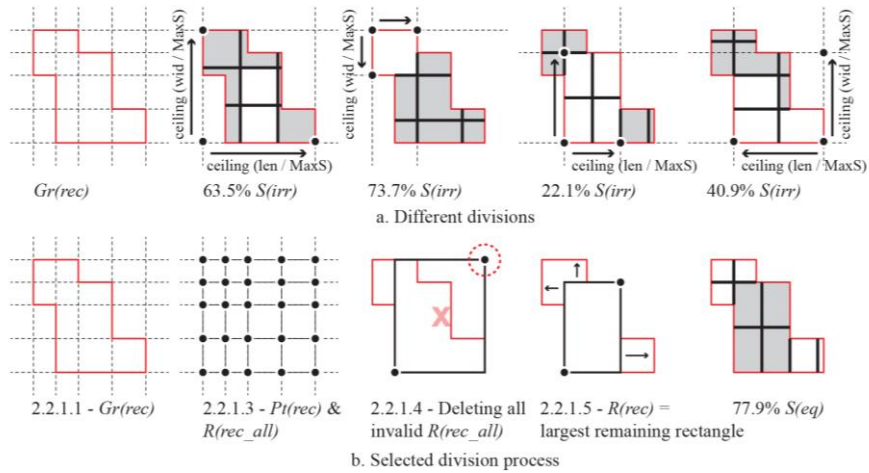

Figure 1. Concave room divisions: a. Different divisions yielding different percentages of $S(irr)$, and b. Selected division process yielding highest percentage of $S(eq)$

$R(rec)$ of a concave room is calculated (as mentioned in steps 2.2.1.1 to 2.2.1.6 of the pseudo code in Table 2, and as shown in figure 1b) by firstly making rectangles by using all the two-point combinations of $Pt(rec)$ as diagonally opposite vertices ($R(rec_all)$). All rectangles in $R(rec_all)$ that have one or more corners outside the room are deleted (as exemplified by step 2.2.1.4 in Figure 1b). Finally, the largest rectangle by area of $R(rec_all)$ is selected as $R(rec)$.

5. Automated Column-Beam Placement

Based on the findings of the empirical analysis, the algorithm undertakes the placement iteratively from the largest to the smallest room. In each iteration, the algorithm calculates an orthogonal grid exclusive to the selected room ($R(n)$). The grid guides the column-beam placement and ensures (maximised) regular division of ceiling. On conclusion of all the iterations, columns are added at convex corners of the floor plan perimeter if they do not have a column assigned from the loop. Lastly, beam centre lines are added at segments of the floor plan perimeter which do not have beam centre lines assigned from the loop. All the notations used in this paper are described in Table 1. Table 2 tabulates the pseudo code of Eelish. The following sub-sections describe the process of column-beam placement for a convex and a concave room.

EELISH: GRASSHOPPER PLUGIN FOR AUTOMATED COLUMN-BEAM
PLACEMENT ON ORTHOGONAL FLOOR PLANS

5.1. CONVEX ROOM PLACEMENT

In the case of a convex room (as shown in Figure 2 and as mentioned in steps 2.1.1 to 2.1.6 in Table 2), the first step is to add points along the length and the width of $R(n)$, such that the respective points are at an equidistant distance as close to but never more than $MaxS$. These points of division ($C(e)$) are calculated by using the ceiling function on divisions of length and width by $MaxS$. An orthogonal grid ($Gr(n)$) is conceived using $C(e)$. Segments of $Gr(n)$ overlapping with beam centre lines added till the previous (room, or) iteration ($B(p)$) are deleted (as shown in step 2.1.2 of Figure 2). Subsequently, columns are added inside $R(n)$ at the points of self-intersections of $Gr(n)$ ($C(in)$). $C(e)$ found within $MinS$ from columns added till the previous (room, or) iteration ($C(p)$) are deleted. $C(e)$ and $C(in)$ are considered the column centre points for $R(n)$, and are added to $C(p)$. $Gr(n)$ is considered the beam centre lines for $R(n)$, and is added to $B(p)$.

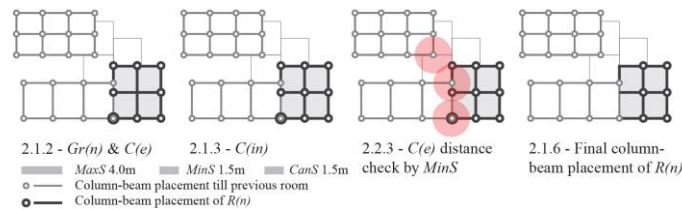

Figure 2. Step by step column-beam placement in a convex room.

5.2. CONCAVE ROOM PLACEMENT

In the case of a concave room (as discussed in section 4 and as mentioned in steps 2.2.1 to 2.2.11 in Table 2), firstly, $R(rec)$ is calculated. Subsequently, the grid of the entire room is calculated; followed by adding columns to support the irregularly divided portions. Finally, columns are distance checked as elaborated in the following sub-sections. Figure 3 shows the important steps and the different column notations used in the algorithm with the example of a concave room of 10 sides.

5.2.1. Division Grid

$C(e)$ and $Gr(n)$ are calculated for $R(rec)$ (as shown in step 2.2.3 in Figure 3 and as mentioned in step 2.2.2 in Table 2) the same way they are calculated for a convex room, i.e., by assuming $R(rec)$ to be a convex room. $Gr(n)$ is subsequently extended to the remaining portions of $R(n)$. Segments of $Gr(n)$ overlapping with $B(p)$ are deleted. Inside columns ($C(in)$) are added at the points of self-intersections of $Gr(n)$. $Gr(n)$ is extended from $R(rec)$ to $R(n)$. The extension not only minimises $S(irr)$, but also pushes it to the

geometrical and visual periphery of the room (green and blue slabs in step 2.2.5 of Figure 3).

5.2.2. Slabs of Irregular Ceiling Division

At this point, $S(irr)$ is supported by columns on only one side. Portions (or slabs) of $S(irr)$ may need to be supported by additional columns at other corners. The distance checks on these potential additional columns are calculated by $MinS$ on regularly supported slabs of $S(irr)$ and by $CanS$ on slabs of $S(irr)$ that may be cantilevered. To address this, $S(irr)$ is divided into two types –

- $S(irr_reg)$: Slabs adjacent to neighbouring rooms that will be regularly supported by columns added in the iterative loops of the neighbouring rooms even if columns are not added in the current iteration (blue slabs in step 2.2.5 of Figure 3).
- $S(irr_canti)$: Slabs abutting the floor plan perimeter that will become cantilevered slabs if additional columns are not added at other corners (green slabs in step 2.2.5 of Figure 3). In other words, if $S(irr_canti)$ is not wide enough to need additional columns, they become cantilever slabs. Since they are not adjacent to neighbouring rooms, the nature of their support – regular or cantilevered – is to be decided in the current iteration.

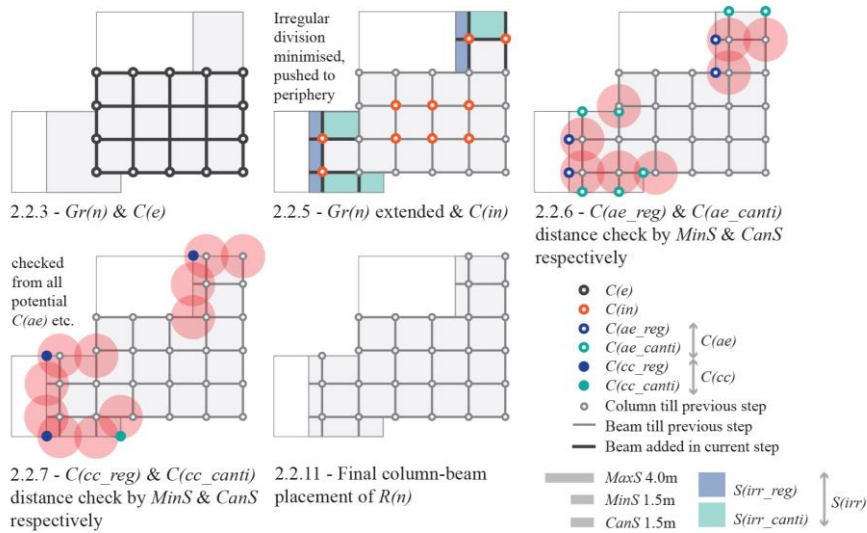

Figure 3. Step by step column-beam placement in a concave room.

5.2.3. Potential Additional Columns of $S(irr)$

On both $S(irr_reg)$ and $S(irr_canti)$, potential columns are added, which are subsequently distance checked by $MinS$ and $CanS$, respectively. Since

EELISH: GRASSHOPPER PLUGIN FOR AUTOMATED COLUMN-BEAM
PLACEMENT ON ORTHOGONAL FLOOR PLANS

$S(irr_reg)$ slabs are adjacent to neighbouring rooms, potential columns on $S(irr_reg)$ are added at the intersections of $Gr(n)$ and the edges of the neighbouring rooms ($C(ae_reg)$), and at convex corners of $R(n)$ that are incident on the edges of the neighbouring rooms ($C(cc_reg)$). In the case of $S(irr_canti)$, since the slabs are abutting the floor plan perimeter, potential columns are added on $S(irr_canti)$ at the intersections of $Gr(n)$ and the floor plan perimeter ($C(ae_canti)$), and at convex corners of $R(n)$ that are incident on the floor plan perimeter ($C(cc_canti)$). Potential columns $C(ae_reg)$ and $C(ae_canti)$ are collectively saved for later use as $C(ae)$.

5.2.4. Distance Checks and Final Column Beam

As shown in steps 2.2.6 and 2.2.7 of Figure 3, and as mentioned in steps 2.2.6 and 2.2.7 in Table 2; $C(ae_reg)$ and $C(ae_canti)$ are distance checked by $MinS$ and $CanS$, respectively, from both $C(e)$ and $C(in)$; and $C(cc_reg)$ and $C(cc_canti)$ are distance checked by $MinS$ and $CanS$, respectively, from all of $C(e)$, $C(in)$ and $C(ae)$. Subsequently; $C(e)$, $C(in)$, $C(ae_reg)$ and $C(cc_reg)$ found within $MinS$ from $C(p)$ are deleted; and $C(ae_canti)$ and $C(cc_canti)$ found within $CanS$ from $C(p)$ are deleted. Distance checked $C(e)$, $C(in)$, $C(ae_reg)$, $C(ae_canti)$, $C(cc_reg)$, and $C(cc_canti)$ are the column centre points for $R(n)$, and are added to $C(p)$. $Gr(n)$ is added to $B(p)$.

TABLE 1. Notations used in the paper.

Notation	Description
$B(p)$	Beam centre lines added till the previous iteration of the loop
$C(ae)$	Columns at the edges of $R(n)$ excluding the edges of $R(rec)$
$C(ae_canti)$	$C(ae)$ not on the edges of neighbouring rooms
$C(ae_reg)$	$C(ae)$ on the edges of neighbouring rooms
$C(cc)$	Columns at the convex corners of $R(n)$
$C(cc_canti)$	$C(cc)$ not on the edges of neighbouring rooms
$C(cc_reg)$	$C(cc)$ on the edges of neighbouring rooms
$C(e)$	Columns at the edges of $R(rec)$
$C(in)$	Columns inside $R(n)$
$C(p)$	Columns added till the previous iteration of the loop
$CanS$	Maximum allowed span of cantilever slab
$Gr(n)$	Orthogonal grid of $R(n)$ made using $C(e)$
$Gr(rec)$	Orthogonal grid of $R(n)$ made by overlaying grids on all walls
$MaxS$	Maximum allowed span of slab
$MinS$	Minimum allowed span of slab
$Pt(rec)$	All points of self-intersections of $Gr(rec)$
$R(n)$	The selected room in the current iteration of the loop
$R(rec)$	Largest rectangle that can be inscribed in $R(n)$
$R(rec_all)$	Rectangles made from all two-point combinations of $Pt(rec)$
$S(eq)$	Slabs of $R(n)$ that are divided equidistant
$S(irr)$	Slabs of $R(n)$ that are divided irregularly
$S(irr_reg)$	$S(irr)$ adjacent to neighbouring rooms
$S(irr_canti)$	$S(irr)$ abutting the floor plan perimeter

TABLE 2. Pseudo code of column-beam placement.

Step no.	Step
Input:	Floor plan, $MaxS$, $MinS$ and $CanS$ from user
1	Sort the rooms in descending order of area <i>// convex room given priority over concave room of same area</i>
2	For each room in the sorted list:
2.1	If $R(n)$ is convex
2.1.1	Divide length of $R(n)$ into Ceiling $(length(R(rec)) / MaxS)$ parts Divide width of $R(n)$ into Ceiling $(width(R(rec)) / MaxS)$ parts $C(e)$ = Points of divisions
2.1.2	$Gr(n) = R(n)$ bound orthogonal grid made using $C(e)$ Delete portions from $Gr(n)$ overlapping with $B(p)$
2.1.3	$C(in)$ = Points of self-intersection of $Gr(n)$ excluding $C(e)$
2.1.4	Delete columns from $C(e)$ that are at $< MinS$ from $C(p)$
2.1.5	$C(p) = C(p) + C(e) + C(in)$ <i>// final column centres</i>
2.1.6	$B(p) = B(p) + Gr(n)$ <i>// final beam centre lines</i>
2.2	Else <i>// i.e. R(n) is concave</i>
2.2.1	Calculate $R(rec)$:
2.2.1.1	$Gr(rec)$ = Orthogonal grid made using all corners of $R(n)$
2.2.1.2	$Pt(rec)$ = Points of self-intersection of $Gr(rec)$
2.2.1.3	$R(rec_all)$ = Rectangles made by using points from Combination($Pt(rec)$,2) list as diagonal corner points
2.2.1.4	Delete rectangles from $R(rec_all)$ that have one or more corner(s) outside $R(n)$
2.2.1.5	$R(rec)$ = Largest rectangle by area of $R(rec_all)$
2.2.2	Divide length of $R(rec)$ into Ceiling $(length(R(rec)) / MaxS)$ parts Divide width of $R(rec)$ into Ceiling $(width(R(rec)) / MaxS)$ parts $C(e)$ = Points of divisions
2.2.3	$Gr(n) = R(rec)$ bound orthogonal grid made using $C(e)$ Delete portions from $Gr(n)$ overlapping with $B(p)$
2.2.4	Extend $Gr(n)$ to the edges of $R(n)$
2.2.5	$C(in)$ = Points of self-intersection of $Gr(n)$ excluding $C(e)$
2.2.6	$C(ae)$ = Points of intersection of $Gr(n)$ and $R(n)$ edges $C(ae_reg)$ = $C(ae)$ on the edges of neighbouring rooms and at $>$ $MinS$ from $C(e)$ and $C(in)$ $C(ae_canti)$ = $C(ae)$ not on the edges of neighbouring rooms and at $>$ $CanS$ from $C(e)$ and $C(in)$
2.2.7	$C(cc)$ = Columns at convex corners of $R(n)$ $C(cc_reg)$ = $C(cc)$ on the edges of neighbouring rooms and at $>$ $MinS$ from $C(e)$, $C(in)$, $C(ae)$ $C(cc_canti)$ = $C(cc)$ not on the edges of neighbouring rooms and at $>$ $CanS$ from $C(e)$, $C(in)$, $C(ae)$
2.2.8	Delete columns from $C(e)$, $C(in)$, $C(ae_reg)$ and $C(cc_reg)$ that are at $< MinS$ from $C(p)$
2.2.9	Delete columns from $C(ae_canti)$ and $C(cc_canti)$ that are $< CanS$ from $C(p)$
2.2.10	$C(p) = C(p) + C(e) + C(in) + C(ae_reg) + C(ae_canti) + C(cc_reg) +$ $C(cc_canti)$ <i>// final column centres</i>
2.2.11	$B(p) = B(p) + Gr(n)$ <i>// final beam centre lines</i>
2.3	End if
3	Next
4	Add columns at convex corners of the floor plan perimeter, if absent

EELISH: GRASSHOPPER PLUGIN FOR AUTOMATED COLUMN-BEAM PLACEMENT ON ORTHOGONAL FLOOR PLANS

5 Add beam centre lines at segments of the floor plan perimeter, if absent
Output: $C(p)$ as column placements
 $B(p)$ as beam centre line placements

6. Eelish Grasshopper Plugin

The algorithm discussed in this paper is released as a free Grasshopper plugin named Eelish. It may be downloaded from the food4rhino website. It uses two components (as shown in Figure 4) to generate the column-beam placements. To reduce the barrier to entry of using Eelish, the components are designed to have four simple inputs as mentioned in section 2.3. The two components are briefly described as following –

- *Closed Curve Generator*: Converts any curve network (of closed and/or open and/or overlapping curves) into watertight closed curves. It is used for preparing floor plan curves for column-beam placement. The algorithm of this component is beyond the scope of this paper.
- *Column-beam Placement*: Executes the algorithm discussed in this paper. It uses the closed curves generated in the former component as the input for floor plan (called ‘Rooms’), along with values for $MaxS$, $MinS$ and $CanS$. If the value of $CanS$ is not specified by the user, the value of $MinS$ is used for $CanS$ too. The outputs of this component are the column centres as ‘points’ and beam centre lines as ‘curves’.

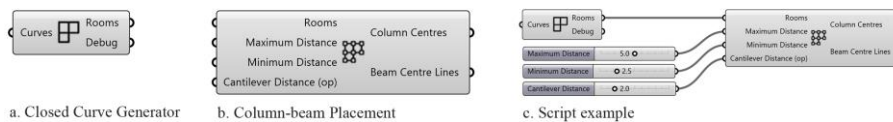

Figure 4. Eelish plugin components and example script.

7. Results and Discussion

Figure 5 shows column-beam placements generated by Eelish on four floor plans with varying $MaxS$, $MinS$ and $CanS$. Even though the layouts made by Eelish satisfy the two objectives (as mentioned in section 2.3) quantitatively, they were qualitatively reviewed by architects and structural engineers to ascertain Eelish’s suitability in practical project workflows.

7.1. QUALITATIVE REVIEW

30 column-beam placement layouts generated by Eelish (including the ones shown in Figure 5) were shown to 30 architects and 30 structural engineers for a qualitative review of the usability of the layouts. All the architects and

the structural engineers had a minimum of 5 years of professional experience. The group of architects did not include anyone from the group of architects involved in the empirical analysis of the manual process. The participants were informed about *MaxS*, *MinS* and *CanS* of the layouts.

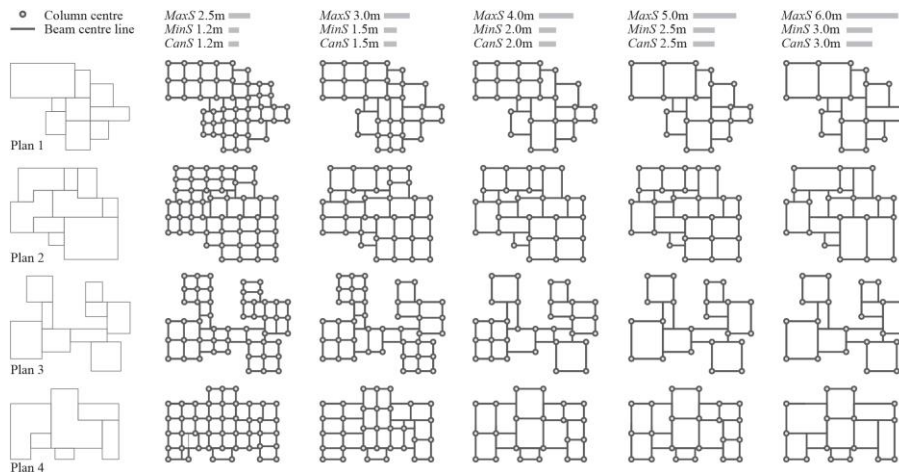

Figure 5. Column-beam placements by Eelish on different floor plans.

They were not explicitly informed about the objective of the algorithm of maximising regular ceiling division. The information was skipped to understand the universal applicability of Eelish. The architects and the structural engineers were asked to rate the layouts against the following questions –

- *Architects*: “Given that the floor plan, *MaxS*, *MinS* and *CanS* are fixed, how would you rate this column centre point and beam centre line layout as a deliverable to the structural engineer for further calculations?”
- *Structural Engineers*: “Given that the floor plan, *MaxS*, *MinS* and *CanS* are fixed, how would you rate this column centre point and beam centre line layout as a drawing sent by the architect for structural calculations?”

A Likert scale of ‘Highly Satisfactory’, ‘Satisfactory’, ‘Neutral’, ‘Unsatisfactory’, and ‘Highly Unsatisfactory’ was used for rating. The descriptions of the scale were allotted 5, 4, 3, 2, and 1 as values, respectively, for statistical calculations. Table 3 shows the summary of the qualitative review of the layouts. 93.5% of the reviews by architects and 83.6% of the reviews by structural engineers categorised the layouts as ‘Satisfactory’ or better. 2.9% of the reviews by architects and 4.5% of the reviews by structural engineers categorised the layouts as ‘Unsatisfactory’ or

EELISH: GRASSHOPPER PLUGIN FOR AUTOMATED COLUMN-BEAM
PLACEMENT ON ORTHOGONAL FLOOR PLANS

worse. The layouts have a mean approval of 4.01/5.00 by architects and 3.80/5.00 by structural engineers. The comparatively lower mean approval by the structural engineers may be attributed to higher number of staggered beam joints in the layouts generated by Eelish compared to the layouts generated by grids. Since the staggered beam joints are visually flushed to the walls, they are not expected to be deemed undesirable by architects.

TABLE 3. Qualitative rating of usability of 30 column-beam placement layouts (generated by Eelish) by 30 architects and 30 structural engineers.

Likert Description	Architects	Engineers
Highly Satisfactory (5)	9.2% (83)	2.7% (24)
Satisfactory (4)	84.3% (759)	80.9% (728)
Neutral (3)	3.8% (34)	11.9% (107)
Unsatisfactory (2)	2.1% (19)	3.3% (30)
Highly Unsatisfactory (1)	0.8% (7)	1.2% (11)
Total Reviews	900	900
Mean Approval (out of 5)	4.01	3.80
Standard Deviation	0.52	0.59
Coefficient of Variation	12.9%	15.4%

Coefficients of variation of 12.9% and 15.4% by architects and structural engineers, respectively, indicate that even if a few reviews of a given layout is ‘Unsatisfactory’ or worse, the mean approval of the given layout is seldom an outlier in the ‘Unsatisfactory’ or ‘Highly Unsatisfactory’ category.

7.2. IMPLICATIONS

Majority of the buildings that are designed and/or constructed outside the avant-garde practices are orthogonal (Steadman, 2006). Consequently, Eelish has the potential of impacting the design delivery workflow by emancipating architects from the uninventive manual repetition of column-beam placement. From the performative perspective, with additional data on site specific cost per unit of columns, beams and slabs, the column-beam placement layout incurring minimum cost may be calculated by optimising values of *MaxS*, *MinS* and *CanS*. The compounding effect of the time and cost savings shall enable redirection of resources towards more creative endeavours and/or towards making design services less expensive. As a solution to the problem of design services’ exclusivity to the affluent, Eelish is conceived as an important cog in the wheel of an automated (and consequently cheap) alternative of design delivery to the majority of the world population that cannot afford architects. Alongside Eelish, other automated solutions for generating floor plans, furniture layouts, and MEP layouts will need to be developed as part of the wheel.

8. Conclusion

The layouts generated by Eelish satisfy the objectives of column-beam placement. They have a qualitative ‘Satisfactory’ or better approval rating of 93.5% by architects and 83.6% by structural engineers. These can act as starting baseline for local modifications. Extending the column-beam grid of the largest inscribable rectangle in a concave room to the entire room maximises regular ceiling division. The algorithm is to be expanded to address the intricacies of one way and two-way slabs, include columns and beams at pre-determined locations (if needed), and include ways to modify the sequence of rooms for iteration. Subsequently, the algorithm shall be released as a free plugin on the AutoCAD platform to facilitate last-mile access of the technology. It is imperative that we automate column-beam placement of orthogonal designs to emancipate architects from uninventive repetition and enable them in redirecting project resources by drastically reducing workhours of the process.

Acknowledgements

The author will like to thank Somen Chakraborty, Professor Emeritus, Jadavpur University and Debasish Das, Associate Professor, Jadavpur University for their guidance and comments on the research methodology.

References

- BENZU, J., 2011. *Thumb rules for designing a Column layout*. [online] Civil Engineering Projects. Available at: <http://www.civilprojectsonline.com/building-construction/thumb-rules-for-designing-a-column-layout-building-construction/> [Accessed 02 Nov. 2020].
- CROFT, H.T., FALCONER, K.J. AND GUY, R.K., 1991. *Unsolved Problems in Geometry*. New York, United States: Springer-Verlag, 23.
- HERR, C. AND FISCHER, T., 2013. Generative Column and Beam Layout for Reinforced Concrete Structures in China. In: *Proceedings of the 15th International Conference on Computer Aided Architectural Design Futures (CAAD Futures 2013)*. Shanghai, China, 84-95.
- HERR, C. AND FISCHER, T., 2014. A Notation to Aid Column and Beam Layout Design for Reinforced Concrete Construction in China. In: *Proceedings of the 19th International Conference on Computer-Aided Architectural Design Research in Asia (CAADRIA 2014)*. Kyoto, Japan, 399-408.
- MONDAL, J., 2018. Automated Column and Beam Placement on Single-storeyed Convex Orthogonal Floor Plans. In: *Proceedings of Neo-International Conference on Habitable Environments (NICHE 2018)*. Delhi NCR, India: White Falcon Publishing, 129-134.
- NIMTAWAT, A. AND NANAKORN, P., 2009. Automated Layout Design of Beam-slab Floors Using a Genetic Algorithm. *Computers & Structures*, 87(21), 1308-1330.
- RAJAPAKSE, R.A., 2016. *Construction Engineering Design Calculations and Rules of Thumb*. Cambridge, United States: Butterworth-Heinemann.
- SACKS, R., WARSZAWSKI, A. AND KIRSCH, U., 2000. Structural Design in an Automated Building System. *Automation in Construction*, 10(1), 181-197.
- SHAW, D., MILES, J. AND GRAY, A., 2008. Determining the Structural Layout of Orthogonal Framed Buildings. *Computers & Structures*, 86(19), 1856-1864.
- STEADMAN, P., 2006. Why Are Most Buildings Rectangular?. *Architectural Research Quarterly*, 10(2), 119-130.

SPATIOTEMPORAL MODELLING: SPREAD OF COVID-19 IN EDUCATIONAL SETTINGS

The role of Architecture in a Pandemic.

PAULA GOMEZ Z., KHATEREH HADI, MATTHEW SWARTS,
OLGA KEMENOVA

*Machine Learning and Data Analytics Branch, ATAS,
Georgia Tech Research Institute
75th 5th Street NW, 6th floor. Atlanta, GA 30308, USA*

Email address:

*paula.Gomez@gtri.gatech.edu, khatereh.Hadi@gtri.gatech.edu,
matthew.Swartz@gtri.gatech.edu, olga.Kemenova@gtri.gatech.edu*

AND

MARCELO BERNAL

*Perkins&Will Design Process Lab
1315 Peachtree St NE, Atlanta, GA 30309, USA
Email address: marcelo.Bernal@perkinswill.com*

Abstract. In this study, we explore the role of Architecture within the COVID-19 pandemic. Our research focuses on the role of buildings and smaller-scale spaces on virus spread instead of large-scale environments. The approach tests the scenarios through which the interaction between humans and enclosed built environments impacts virus exposure probabilities. We propose a comprehensive parametric modeling approach of the most significant parameters shown to impact COVID-19 spread in educational buildings. This publication presents the models by aspect, extending our initial research on the Spatiotemporal Modeling of COVID-19 Spread in Built environments based on human-to-human and fomite contagion. It includes the most significant parameter of the spread: airborne transmission. The proof-of-concept study for this research is a K-12 educational setting.

Keywords: *Spatiotemporal Modelling; Spatiotemporal Analytics; COVID-19 Pandemic; Educational Settings, Building Analytics.*

ملخص. في هذه الدراسة، نستكشف دور العمارة في جائحة COVID-19. يركز بحثنا على دور المباني والفراغات ذات المساحات الصغيرة في انتشار الفيروسات بدلاً من البيئات واسعة النطاق. يختبر هذا النهج السيناريوهات التي من خلالها يؤثر التفاعل بين البشر والبيئات المبنية المغلقة على احتمالات التعرض للفيروس. نقترح نهجاً شاملاً للنمذجة البارامترية لأهم المعلمات والمتغيرات التي لوحظ تأثيرها على انتشار COVID-19 في المباني التعليمية. يقدم هذا البحث النماذج باعتبار كل الجوانب، مما يوسع مبحثنا الأولي حول النمذجة الزمانية المكانية لانتشار COVID-19 في البيئات المبنية على أساس العدوى من إنسان إلى إنسان وعبر جميع المواد ناقلة العدوى. ويشمل البحث المتغير الأكثر أهمية للانتشار ألا وهو النقل الجوي. أما دراسة إثبات المفهوم لهذا البحث فهي عبارة عن بيئة تعليمية لسن رياض الأطفال وحتى الصف الثاني عشر.

الكلمات المفتاحية: النمذجة الزمانية المكانية، التحليل الزماني المكاني، جائحة الكورونا COVID-19، الفراغات التعليمية، تحليلات المباني.

1. Introduction

Most of the simulation and modeling research about forecasting the spread of the SARS-CoV-2 virus have focused on large-scale outcomes such as the number of daily cases at the city, county, and country levels. The preventative measures tested in such studies aim for what we all know as "flattening the curve," driven by infectious disease control parameters, focused on characteristics of the virus, such as the infection rate (R_0) and the behavior of the population, such as wearing masks in public spaces and social distancing. However, we have witnessed daily increases in COVID-19 cases coinciding with gatherings in enclosed small-scale spaces, reopening of schools, and returning to work in offices, among other scenarios. All of these are related to environments at the building-scale. This paper intends to help understand the parameters that architects should consider helping reopen schools by managing, and hopefully avoiding, potential outbreaks.

Even though we learned that enclosed spaces play a significant role in the spread of the virus, most models for forecasting the virus spread have only included non-spatial parameters, such as the infection rates, behavior of the population such as wearing Personal Protective Equipment (PPE), respecting occupancy rates (Jones, N. R., Qureshi, Z. U., Temple, R. J., Larwood, J. P., Greenhalgh, T., & Bourouiba, L., 2020), geographical location (Giuliani et al., 2020; Ma, 2020), distance from the outbreak epicenters (Rabajante, 2020), and social distancing (Giuliani et al., 2020; Kim et al., 2018). On another scale, virology science has characterized the SARS-CoV-2 virus based on R_0 , stability on materials, direct sunlight, temperature, and humidity (Jia et al., 2020). This research proposes a Spatiotemporal Model that integrates virus data from experimental research, human behavior as the critical mechanism for virus transmission, and the building that offers the conditions for the virus transmission to occur (Figure 1). This study extends previous research on

SPATIOTEMPORAL MODELLING: SPREAD OF COVID-19 IN EDUCATIONAL SETTINGS

Spatiotemporal Modeling (Gomez, Hadi, Swarts, Kemenova, 2020) to include airflow dynamics of airborne transmission, recently identified as one of the primary transmission modes of SARS-CoV-2.

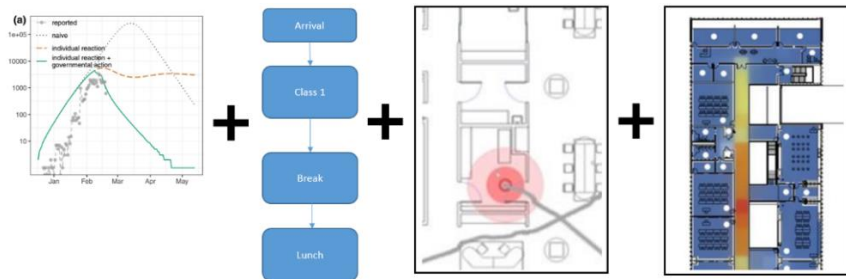

Figure 1. Spatiotemporal conceptual framework, superimposing four layers of information: Viral characteristics of spread by geographic location, Organizational Analytics, which led to agent-based behavior analytics and overlaid to Spatial Analytics, including Airflows.

Building occupancy, determined by the program and dynamic environmental conditions such as temperature, humidity, and lighting, impacts the spatiotemporal dynamics of the virus spread. In addition, the condition of humans occupying buildings, such as the severity of their symptoms (asymptomatic, mild, and severe), the activities and actions, and the use of PPE, further determines the spread. (Lauer, S. A., Grantz, K. H., Bi, Q., Jones, F. K., Zheng, Q., Meredith, H. R., Azman N., Reigh, & Lessler, J., 2020). Furthermore, the human-environment relations, such as the distance to the infection source, also determine coronavirus's spread. The current evidence shows that initially suggested 6-foot distance might not be enough depending on the exhalation actions of source agent such as singing or screaming, representing longer virus travel distances than silent or talking (Jones et al., 2020). The airborne diffusion of infected droplets can spread beyond the 6-foot distance (Settia et al., 2020) up to 23-27 feet at peak exhalation speeds (Bourouiba, 2020; Guo et al., 2020), based on the direction of airflow and HVAC zoning (CDC, 2020; Liu et al., 2020; Lu et al., 2020).

Recent COVID-19 research highlights how SARS-CoV-2 virus (cause of COVID-19 disease) has longer stability on surfaces materials such as plastic, stainless steels, metal, and wood compared to copper (Chin et al., 2020; Dietz et al., 2020; Kampf et al., 2020; van Doremalen et al., 2020) and how environmental conditions, such as temperature, relative humidity levels, and light conditions changes SARS-CoV-2 stability on surfaces. (Casanova et al., 2010; Chin et al., 2020; Pawar et al., 2020). Survival rates (half-lives) of SARS-CoV-2 at 20 °C is higher compared to 40 °C (Riddell, S., Goldie, S., Hill, A. et al., 2020), in low (10%-40%) and high (60%-100%) relative humidity levels compared to moderate relative humidity levels (40%-60%)

(Dietz et al., 2020; Moriyama et al., 2020) and in dim conditions compared to light exposure (Schuit et al., 2020). Considering the impact of building and environmental parameters on the virus spread and lack of studies on SARS-CoV-2 spread modeling including such parameters, our research addresses this gap by creating and implementing a comprehensive spatiotemporal model by including viral characteristics, spatial parameters, airflow modeling, operations, and building occupancy patterns to understand the virus spread. Our end goal is to provide design and organizational guidelines to control the virus spread and reopen educational settings.

2. Methodology

Spatiotemporal modeling combines spatial analytics with behavioral and building analytics, integrating operational parameters and environmental characteristics. This research extends the spatiotemporal occupancy in building settings research by Gomez-Zamora (2017, 2019) and the spatiotemporal modeling research done in 2020 (Gomez-Zamora et al., 2020) focusing on educational environments. Our spatiotemporal model integrates four types of data into a single model for analytics of the spread: Spatial Layout and Analytics, Process Flows, Behavior-Analytics, and Virus characteristics, and Preventive policies.

In order to model the dynamics of COVID-19 spread within the built environments, we identified and implemented a set of influential critical parameters. We also included an option to weight these parameters in future iterations. These parameters include building features such as surface materials, exposure to daylight (Figure 2), occupancy (Figure 3), ambient temperature and relative humidity level, and HVAC configurations; behavioral parameters such as occupancy levels, the distance between users and occupancy rates (Figure 4), occupancy schedule, time of occupancy, sequence of places visited, activities, and PPE levels; virus parameters such as survival time on different materials, in the air, at different temperatures, light and humidity conditions, number of cases by the total population in the area of the building, virus travel distance based on particle size; and source agent actions such as silence, talking, sneezing, coughing, screaming/signing (Jones et al., 2020).

3. Spatiotemporal Modeling Parameters for COVID-19 Spread

Spatiotemporal Modeling is a comprehensive multi-dimensional modeling approach that includes multiple parameters that play a significant role in the virus spread dynamics. The model presented in this study focuses on

SPATIOTEMPORAL MODELLING: SPREAD OF COVID-19 IN EDUCATIONAL SETTINGS

educational settings, specifying more precisely defined parameters for the case study, such as demographics and recent findings in SARS-CoV-2 research and airflow dynamics as a vector impacting the spread.

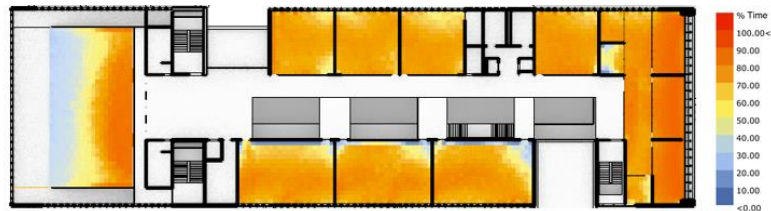

Figure 2. Percentage of the time occupied areas are within the acceptable daylight threshold between 300 lux and 3000 lux during operational hours from 8:00 AM to 6:00 PM

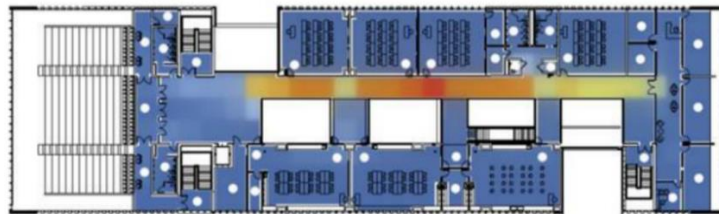

Figure 3. The layout of a K-12 educational setting, indicating the higher concentration of routes across space in red and lower in blue due to the layout itself.

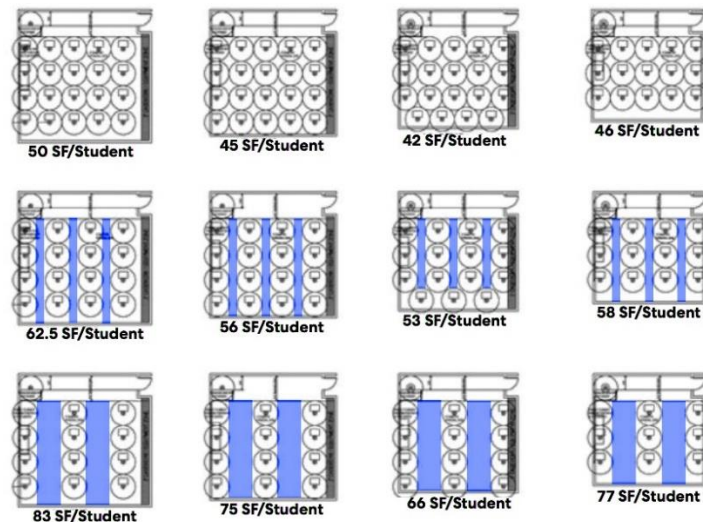

Figure 4. Occupancy re-design to analyze the pandemic COVID-19 scenarios. Classroom areas from left to right: 1000 to 700 sq ft. Adapted from Perkins and Will Human Experience Lab, K-12 Capacity Guidelines (<https://k12roadmap.perkinswill.com/strategies/>).

From studying the most recent research, we have identified a list of parameters and their current values. The parameters are organized into four categories: The K-12 Building Parameters, the K-12 specific school Organizational parameters; the Agent (occupants including students and teachers) parameters; and the Virus characteristics.

K-12 Educational Building Parameters include Occupancy rates due to layout; Materials of surfaces (linked to virus survival time); direct sunlight exposure (ranges); temperature and humidity levels (ranges); and HVAC systems design (Location of inlets and outlets). K-12 Organizational Parameters include the architectural program (i.e., K-12); Organizational programming: Sequence and duration of activities; Frequency of room occupancy due to programming; Length of stay due to programming; Probability of occupancy rates due to programming; Probability of surface touch due to programming (Handles, bathroom surfaces, etc.)

The Agents Parameters include the agent role (Student, Teacher, Staff); Health status (Healthy or Sick (Spreader)). A Spreader might be asymptomatic, have mild, severe, or critical symptoms. The level of symptoms is linked to the contagion time period (14 to 25 days)). Other parameters include PPE levels (No PEE, Level 1-5 (95%)); Distance from/to source (0 – 6 feet); and time of exposure (exponentially increasing risk after 15 min within 24 hours).

Virus Characteristics list a set of parameters, including the R0 or infection rate, Virus travel distance from the source, Survival time on materials (12 -72 hours), Time that a particle size floats in the air, Survival time under certain lighting conditions (12hrs.-28 days), temperature and humidity. Number of known COVID-19 cases by population, in the building's geographical area, and asymptomatic/Symptomatic population distribution.

The list of parameters presented above was updated from our previous research based on the most current literature review. However, the model is strategically set so the virus characteristics may be replaced by the new virus strain if required. From these parameters and workflows within the environment, we created a spatiotemporal model that also incorporates virus characteristics in different scenarios to compare risk. We made several models to finally integrate them into a simulation model that calculates two outputs: Probabilities of Spatial Contamination and Probabilities of Contagion Risk. The first one is assigned to a spatial cell (1sqft), and the second one is assigned to an agent at a specific time.

4. Spatiotemporal Model

A K-12 high school case study was used to introduce a proof-of-concept of the spatiotemporal modeling. The model's input parameters include the layout of the high school, spatial parameters, airflow, and school organizational processes with students, teachers, administrators, and staff workflows

SPATIOTEMPORAL MODELLING: SPREAD OF COVID-19 IN EDUCATIONAL SETTINGS

representing the building operations. The workflows represent the standard teacher and student activities such as arriving/exiting, classes, breaks, and administrative tasks. We used agent-based modeling to simulate spatial occupancy and movements in the classrooms, using AnyLogic software. A set of agents were created to represent teachers, and another set to represent students and staff. Agents' behavior represents students in different classrooms and areas to perform their daily activities. All possible movement paths are shown in Figure 5. The simulation model is a work-in-progress, created in a parametric modeling environment (i.e., Grasshopper).

Agents are defined with the following attributes: role, tasks, arrival points, activity points, and exit points, as well as their health status (healthy or spreader) and PPE levels. The number of sick agents was defined as a probability of the number of cases at the building location.

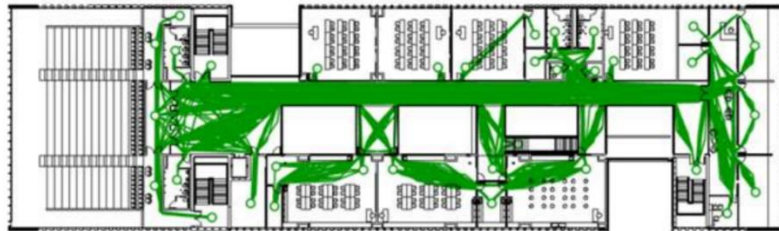

Figure 5. All possible routes generated by the layout, using all origin and destination points, following the school program. We used the Mouse plug-in for Grasshopper, which creates the shortest paths based on fields of view.

A sick agent is defined as a virus spreader during a certain time period. Spreaders could be symptomatic or asymptomatic, and the distribution of sickness levels over the total populations was determined by the current statistics at the time of the modeling, as well as the viral load per agent over time, which was also determined by a specific statistical distribution in the literature (Kilpatrick, A.M., 2020).

A healthy agent is defined as a Contact-tracer (or virus collector). The Contact-tracer records accumulated "time of exposure" to spreaders and to the contaminated space. Based on CDC recommendations, the counter's threshold to raise an "exposed" flag is set to 15 minutes over 24 hours. However, research indicates that this time might differ depending on the initial health condition. The probability of exposure of this agent depends on several factors, such as the time of exposure to virus sources (spreaders or contaminated air), the distance to the source, and the probability of fomite contagion (surface-touch followed by face-touch). The PPE level protection is an agent attribute representing the likelihood of getting or spreading the virus due to the PPE. For this current spatiotemporal model, we defined five

PPE levels: From 0% to 95%, using values defined by the CDC (Center for Disease Control) guidelines (i.e., 95% for N95 masks, decreasing probability of protection over time). Probabilities vary for spreaders and healthy agents.

5. Computational Fluid Dynamics Simulation

The most recent, yet controversial, evidence is aerosol as the dominant route for the transmission of SARS-CoV-2 (Zhang, R., Li, Y., Zhang, A. L., Wang, Y., and Molina, M. J., 2020). To explore aerosol transmission's impact on the virus spread, we implemented Computational Fluid Dynamics (CFD) simulations, developed as an exercise in the Vertically Integrated Project (VIP) research group, conducted by the CFD research sub-team.

At this phase, we included airflow dynamics modeling, implemented using CFD in SimScale. The CFD simulation included several scenarios of a typical classroom with students. The three scenarios were compared to qualitatively understand the impact of airflows on spread dynamics in the air. The variables considered in the simulations were the inlet/outlet locations, dimensions of the inlet and outlet areas, velocity of the airflow entering the room, the pressure of the airflow leaving the room, and location of a sick agent, coughing. The cough was implemented as a 400L/min release of contaminated air. The CFD simulation included incompressible airflow simulation, representing the virus aerosol as "particle traces" shown in red and blue in Figure 8. Blue traces indicate clean air, while red traces indicate contaminated air.

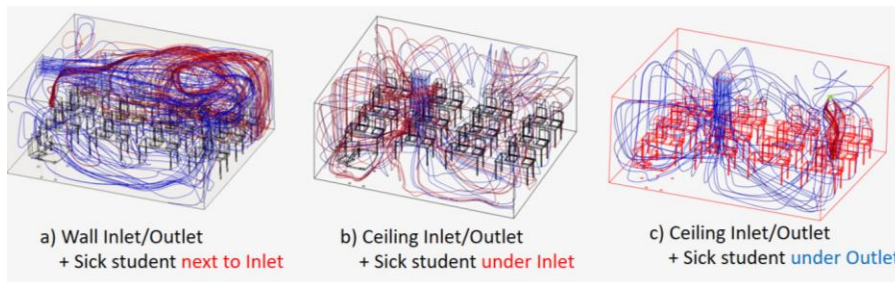

Figure 6: CFD simulation trace airflows of a K-12 classroom. Contaminated airflow is shown in red while clean airflow in blue. Figure a) Inlet/Outlet located on opposite walls; and sick student (coughing, no mask) sitting next to the inlet. B) Inlet/Outlet located on the ceiling, and sick student sitting below the outlet. C) Inlet/Outlet located on the ceiling, and sick student sitting below the inlet.

The model was simplified to perform the simulations more efficiently. The HVAC system configurations represent the two most common HVAC configurations for schools. The input variables for the simulation are the location of inlets and outlets, area of the inlet (0.5x 0.5ft), and outlet (2x2 ft).

SPATIOTEMPORAL MODELLING: SPREAD OF COVID-19 IN EDUCATIONAL SETTINGS

As shown in the figure above (Figures 6), a student coughing in the three different locations presents three risk scenarios. This is a conceptual simulation to exemplify how contaminated air (red) spread through a classroom. No conclusions on viral load can be done since this is not a quantitative simulation. The CDF simulation was done in SimScale Community Version, run on cloud servers. It automatically generated meshes with 2 million cells. An incompressible simulation with a k-omega SST turbulence model and a steady-state simulation were used for this example.

6. Preliminary Results

The Spatiotemporal model integrates spatial and temporal parameters into a comprehensive model to generate two metrics as outputs of the model: A building metric and an agent metric. The building metric is assigned to a spatial cell (1 ft³), a specific time. This metric is the probability of Spatial Viral Contamination as an attribute of a spatial cell. The agent is assigned to the agent as an attribute to the agent at a specific time and location. This metric is the Probability of Agent Exposure to the virus. This probability is directly related to the sequence of activities and exposure to the contaminated spaces or sources over some duration, and exposure accumulates over time by counting the time of exposure to the Spatial Viral Contamination.

This research presents a case study based on the framework developed for spatiotemporal modeling for general building settings. The work for this specific publication is adjusted and refined to Educational settings, considering all details and differences for this particular program and layout and demographics. For example, most of the agents are teenagers, and their asymptomatic transmission rate is higher than other demographics.

Occupancy probability is calculated considering the layout-spatial analytics, specifically integration and operational analytics. Surface contamination is calculated based on the probability of the virus landing on a surface plus the probability of that surface being touched. The primary variable for a contaminated surface is the stability of the virus by the material. The probability of exposure is calculated, including the PPE level, the probabilities of occupancy and touch of contaminated areas, and the number and length of interactions. Virus parameters are sometimes replaced for other viruses, such as influenza when data is not available for SARS-CoV-2 (Yan et al., 2018).

As the research is developing simultaneously with the pandemic, currently focusing on calibrating the quantitative aspect of the metric for "air quality" to be meaningful. This implies the right range of "virus load" per square foot. We designed and plan on testing several representative scenarios to compare the probabilities of virus contamination and agent exposure in building areas

as they move through space. The next step is to quantify the spatiotemporal metrics of "air quality" or "air contamination" to calibrate the probability of both metrics, spatial viral contamination and agent exposure.

In table 1, we present an example of the probability of exposure and spatial contamination. The probability of spatial viral contamination is calculated based on the following parameters: Agent's role and health condition, PPE level, actions performed, and the time a spreader spent on a location. This probability specifically refers to virus stability, for which calculation includes material type, temperature, humidity (constant for this proof-of-concept study), sunlight, and frequency of cleaning (Gomez-Zamora et al., 2010). This research specifically extends to cubic spatial contamination by including airflow dynamics. The Probability of an agent's exposure at the location is the calculation of the exposure time by the PPE level of protection, the action performed, and the probability of face-touch or face-to-face contact. These two latest, in turn, depend on the action being performed and the location. The cumulative probability of risk is calculated over 24 hours. Note that a sensitivity analysis is not implemented in the current model, nor does the viral load concept also be specified at this stage.

TABLE 1. Sample of a Probability of Agent Exposure shown in blue, as the agent moves through space, across time, at each time step (x, y, t).

Agent Role (Teacher)	1	1	1	1	1	1
Agent Health Status (Sick)	0	0	0	0	0	0
Prob of spread (due infection)	0	0	0	0	0	0
Timestamp	5	6	7	8	9	10
Pos X	16.4	16.4	16.4	16.4	16.4	16.4
Pos Y	-0.5	-0.3	-0.1	0	0.2	0.4
PPE level	3	3	3	3	3	3
Prob of Spread (due PPE)	0.25	0.25	0.25	0.25	0.25	0.25
Prob of getting (due PPE)	0.75	0.75	0.75	0.75	0.75	0.75
Surface Touch	F	F	T	T	T	T
Surface Material	0	0	4	4	4	4
Virus survival time (hrs)	3	3	72	72	72	72
Proximity (ft.)	>6	3	3	0	0	0
Probability based on proximity	0	0.25	0.25	0.75	0.75	0.75
Probability of exposure at location	0	0.18	0.18	0.56	0.56	0.56

SPATIOTEMPORAL MODELLING: SPREAD OF COVID-19 IN EDUCATIONAL SETTINGS

7. Discussion

This spatiotemporal model, loaded with virus characteristics, aims to help understand the role of the built environment dynamics in the pandemic and the sensitivity of the parameters towards the spread control. This article presents a comprised list of building analytics and organizational analytical models, including human behavior, modeled as agent-based simulations, and airflow dynamics, applied to a K-12 school. This research extends the initial spatiotemporal occupancy modeling research towards SARS-CoV-2 spread since the spread conditions allow us to model it as abstract attributes of the space.

The proposed spatiotemporal model provides a framework to evaluate the diverse layout and operational scenarios. The purpose is to help understand which strategies would more effectively reduce virus exposure by proposing new protocols (i.e., cleaning frequency, new occupancy rates, new scheduling, and new circulations, among other). The One immediate objective is helping to define guidelines for re-opening schools.

None of the existing software provides integration of such expert knowledge. We designed the spatiotemporal modeling approach based on spatial modeling integrated with agent-based models. We customized the existing platforms to combine both spatial and agent-based modeling, along with environmental attributes and virus characterization models.

The viral parameters included in this model will probably update as most current research on SARS-CoV-2 becomes available. As the proposed framework is parametric, it allows changing the thresholds and the sensitivity of the parameters as the COVID-19 research refines and expands. The biggest challenge we foresee is the validation of this approach with real data. For overcoming this challenge, we plan to reproduce real virology or medical studies as they become available as the first step for validation.

8. Acknowledgments

The Georgia Tech Research Institute (GTRI) funded the majority of this funded through an internal research and development grant (IRAD). We thank the GTRI managers and advisors for their support and valuable feedback. We acknowledge the VIP Spatiotemporal CFD team, Fall 2020, for the work on our research topic through the VIP program. Perkins and Will Design Process Lab sponsored this project by supporting the VIP students, providing the case of study and the spatial and daylight analytics.

9. References

- APPENDICES. (n.d.). Retrieved October 26, 2020, from <https://www.cdc.gov/coronavirus/2019-ncov/php/contact-tracing/contact-tracing-plan/appendix.html>
- BISWAS, K., AND SEN, P. (2020). Space-time dependence of corona virus (COVID-19) outbreak. <http://arxiv.org/abs/2003.03149>
- BOUROUIBA, L. (2020). Turbulent Gas Clouds and Respiratory Pathogen Emissions: Potential Implications for Reducing Transmission of COVID-19. *JAMA*. <https://doi.org/10.1001/jama.2020.4756>
- CASANOVA, L. M., JEON, S., RUTALA, W. A., WEBER, D. J., & SOBSEY, M. D. (2010). Effects of air temperature and relative humidity on coronavirus survival on surfaces. *Applied and Environmental Microbiology*, 76(9), 2712–2717. <https://doi.org/10.1128/AEM.02291-09>
- CHANG, S. L., HARDING, N., ZACHRESON, C., CLIFF, O. M., AND Prokopenko, M. (2020). Modelling transmission and control of the COVID-19 pandemic in Australia. <http://arxiv.org/abs/2003.10218>
- CHIN, A. W. H., CHU, J. T. S., PERERA, M. R. A., HUI, K. P. Y., YEN, H.-L., CHAN, M. C. W., PEIRIS, M., AND POON, L. L. M. (2020). Stability of SARS-CoV-2 in different environmental conditions. *The Lancet Microbe*, 0(0). [https://doi.org/10.1016/S2666-5247\(20\)30003-3](https://doi.org/10.1016/S2666-5247(20)30003-3)
- DIETZ, L., HORVE, P. F., COIL, D. A., FRETZ, M., EISEN, J. A., AND VAN DEN WYMELENBERG, K. (2020). 2019 Novel Coronavirus (COVID-19) Pandemic: Built Environment Considerations To Reduce Transmission. *MSystems*, 5(2). <https://doi.org/10.1128/mSystems.00245-20>
- GIULIANI, D., DICKSON, M. M., ESPA, G., AND SANTI, F. (2020). Modelling and predicting the spatio-temporal spread of Coronavirus disease 2019 (COVID-19) in Italy. <http://arxiv.org/abs/2003.06664>
- GOMEZ ZAMORA, P. A. (2017). Spatiotemporal occupancy in building settings. Doctoral dissertation, Georgia Institute of Technology.
- GOMEZ ZAMORA, P., BAFNA, S., ZIMRING, C., DO, E., AND ROMERO VEGA, M. (2019). Spatiotemporal Occupancy for Building Analytics. *Proceedings of eCAADe 37 / SIGraDi 23 Conference*, the University of Porto, Portugal.
- GOMEZ ZAMORA, P., HADI, K., KEMENOVA, O., SWARTS, M. (2020). Spatiotemporal Modeling of COVID-19 Spread in Built Environments. *Proceedings of SIGraDi 23 Conference*, Universidad Bolivariana, Colombia.
- GUO, Z.-D., WANG, Z.-Y., ZHANG, S.-F., LI, X., LI, L., LI, C., CUI, Y., FU, R.-B., DONG, Y.-Z., CHI, X.-Y., ZHANG, M.-Y., LIU, K., CAO, C., LIU, B., ZHANG, K., GAO, Y.-W., LU, B., AND CHEN, W. (2020). Aerosol and Surface Distribution of Severe Acute Respiratory Syndrome Coronavirus 2 in Hospital Wards, Wuhan, China, 2020. *Emerging Infectious Diseases*, 26(7). <https://doi.org/10.3201/eid2607.200885>
- HADI, K. (2020) Agent-based Simulation for Evaluating the Impacts of Design on Nurses' Spatiotemporal Experience. Doctoral dissertation, Georgia Institute of Technology.
- HAMZAH, F. A. B., LAU, C. H., NAZRI, H., LIGOT, D. V., LEE, G., TAN, C. L., SHAIB, M. K., ZAIDON, U. H. B., ABDULLAH, A. B., CHUNG, M. H., ONG, C. H., CHEWA, P. Y., AND SALUNGA, R. E. (2020). CoronaTracker: World-wide COVID-19 Outbreak Data Analysis and Prediction. *The Bulletin of the World Health Organization*, March 18th.
- HUANG, Y., YANG, L., DAI, H., TIAN, F., AND CHEN, K. (2020). *Bull World Health Organ*. E-pub: 16. <https://doi.org/10.2471/BLT.20.251561>
- JIA, J., DING, J., LIU, S., LIAO, G., LI, J., DUAN, B., WANG, G., AND ZHANG, R. (2020). Modeling the Control of COVID-19: Impact of Policy Interventions and Meteorological Factors. <http://arxiv.org/abs/2003.02985>

SPATIOTEMPORAL MODELLING: SPREAD OF COVID-19 IN EDUCATIONAL SETTINGS

- JONES, N. R., QURESHI Z. U., TEMPLE, R.J, LARWOOD. J.P J, GRENNHALGH, T., AND BOUROUIBA, L. (2020) Two metres or one: what is the evidence for physical distancing in covid-19? *BMJ* 2020; 370 :m3223
- KAMPF, G., TODT, D., PFAENDER, S., AND STEINMANN, E. (2020). Persistence of coronaviruses on inanimate surfaces and their inactivation with biocidal agents. In *Journal of Hospital Infection* 104 (3), 246–251. W.B. Saunders Ltd. <https://doi.org/10.1016/j.jhin.2020.01.022>
- KIM, Y., RYU, H., AND LEE, S. (2018). Agent-based modeling for super-spreading events: A case study of mers-cov transmission dynamics in the republic of korea. *International Journal of Environmental Research and Public Health*, 15(11). <https://doi.org/10.3390/ijerph15112369>
- LAUER, S. A., GRANTZ, K. H., BI, Q., JONES, F. K., ZHENG, Q., MEREDITH, H. R., ... AND LESSLER, J. (2020). The incubation period of coronavirus disease 2019 (COVID-19) from publicly reported confirmed cases: estimation and application. *Annals of internal medicine*, 172(9), 577-582.
- LIN, Q., ZHAO, S., GAO, D., LOU, Y., YANG, S., MUSA, S. S., WANG, M. H., CAI, Y., WANG, W., YANG, L., AND HE, D. (2020). A conceptual model for the coronavirus disease 2019 (COVID-19) outbreak in Wuhan, China with individual reaction and governmental action. *International Journal of Infectious Diseases*, 93, 211–216. <https://doi.org/10.1016/j.ijid.2020.02.058>
- LIU, Y., NING, Z., CHEN, Y., GUO, M., LIU, Y., GALI, N. K., SUN, L., DUAN, Y., CAI, J., WESTERDAHL, D., LIU, X., XU, K., HO, K., KAN, H., FU, Q., AND LAN, K. (2020). Aerodynamic analysis of SARS-CoV-2 in two Wuhan hospitals. *Nature*. <https://doi.org/10.1038/s41586-020-2271-3>
- LU, J., GU, J., LI, K., XU, C., SU, W., LAI, Z., ZHOU, D., YU, C., XU, B., AND YANG, Z. (2020). COVID-19 Outbreak Associated with Air Conditioning in Restaurant, Guangzhou, China, 2020. *Emerging Infectious Diseases*, 26(7). <https://doi.org/10.3201/eid2607.200764>
- MA, Z. (2020). Spatiotemporal fluctuation scaling law and metapopulation modeling of the novel coronavirus (COVID-19) and SARS outbreaks. <http://arxiv.org/abs/2003.03714>
- MARR, L., MILLER, S., PRATHER, K., HAAS, C., BAHNFLETH, W., CORSI, R., TANG, J., HERMANN, H., POLLITT, K., BALLESTER, J., AND JIMENEZ, J. (2020). FAQs on Protecting Yourself from Aerosol Transmission. <https://tinyurl.com/FAQ-aerosols>
- MORIYAMA, M., HUGENTOBLER, W. J., AND IWASAKI, A. (2020). Seasonality of Respiratory Viral Infections. *Annual Review of Virology*, 7(1). <https://doi.org/10.1146/annurev-virology-012420-022445>
- NADIM, S. S., GHOSH, I., AND CHATTOPADHYAY, J. (2020). Short-term predictions and prevention strategies for COVID-2019: A model based study. <http://arxiv.org/abs/2003.08150>
- PAWAR, S., STANAM, A., CHAUDHARI, M., AND RAYUDU, D. (2020). Effects of temperature on COVID-19 transmission. *MedRxiv*, 2020.03.29.20044461. <https://doi.org/10.1101/2020.03.29.20044461>
- PENG, L., YANG, W., ZHANG, D., ZHUGE, C., AND HONG, L. (2020). Epidemic analysis of COVID-19 in China by dynamical modeling. <http://arxiv.org/abs/2002.06563>
- RABAJANTE, J. F. (2020). Insights from early mathematical models of 2019-nCoV acute respiratory disease (COVID-19) dynamics. <http://arxiv.org/abs/2002.05296>
- RIDDELL, S., GOLDIE, AND S., HILL, A. The effect of temperature on persistence of SARS-CoV-2 on common surfaces. *Virol J* 17, 145 (2020). <https://doi.org/10.1186/s12985-020-01418-7>
- SCHUIT, M., GARDNER, S., WOOD, S., BOWER, K., WILLIAMS, G., FREEBURGER, D., & DABISCH, P. (2020). The Influence of Simulated Sunlight on the Inactivation of Influenza Virus in Aerosols. *The Journal of Infectious Diseases*, 221(3), 372—378. <https://doi.org/10.1093/infdis/jiz582>

P. GOMEZ-Z., K. HADI, M. SWARTS, O. KEMENOVA, M. BERNAL

- SETTIA, L., PASSARINI, F., DE GENNAROA, G., BARBIERI, P., PERRONE, M. G., BORELLI, M., PALMISANI, J., DI GILIO, A., PISCITELLI, P., AND MIANI, A. (2020). Airborne Transmission Route of COVID-19: Why 2 Meters/6 Feet of Inter-Personal Distance Could Not Be Enough. *International Journal of Environmental Research and Public Health*, 17(8), 2932. <https://doi.org/10.3390/ijerph17082932>
- VAN DOREMALEN, N., BUSHMAKER, T., MORRIS, D. H., HOLBROOK, M. G., GAMNLE, A., WILLIAMSON, B. N., TAMIN, A., HARCOURT, J. L., THORNBURG, N. J., GERBER, S. I., LLOYD-Smith, J. O., de Wit, E., AND MUNSTER, V. J. (2020). Aerosol and Surface Stability of SARS-CoV-2 as Compared with SARS-CoV-1. *New England Journal of Medicine*. <https://doi.org/10.1056/nejmc2004973>
- YAN, J., GRANTHAM, M., PANTELIC, J., BUENO DE MESQUITA, P. J., ALBERT, B., LIU, F., EHRMAN, S., AND MILTON, D. K. (2018). Infectious virus in exhaled breath of symptomatic seasonal influenza cases from a college community. *Proceedings of the National Academy of Sciences*, 115(5), 1081 LP – 1086. <https://doi.org/10.1073/pnas.1716561115>
- ZHANG, R., LI, Y., ZHANG, A. L., WANG, Y., AND MOLINA, M. J. (2020). Identifying airborne transmission as the dominant route for the spread of COVID-19. *Proceedings of the National Academy of Sciences*.

D2.P1.S1

ARCHITECTONIC LANGUAGES III

PARAMETRIC IRANIAN-ISLAMIC MUQARNAS AS DRIVERS FOR DESIGN FOR FABRICATION AND ASSEMBLY VIA UAVS

Parametric Analysis and Synthesis of Iranian-Islamic Muqarnas

ERFAN ZAMANI & THEODOROS DOUNAS

*The Scott Sutherland School of Architecture & Built Environment,
Robert Gordon University, Aberdeen, Scotland*

Email address: e.zamanigoldeh@rgu.ac.uk

Email address: t.dounas@rgu.ac.uk

Abstract. This study proposes a DfMA (from design to assembly) based on Unmanned Aerial Vehicle (UAV) and uses Iranian-Islamic Muqarnas as the case study due to their geometric modularity. In Islamic architecture, different geographic regions are known to have used various design and construction methods of Muqarnas. There are four main specifications of the Muqarnas that define to which category they belong; first, its three-dimensional shape, that provides volume. Secondly, the size of its modules is variable. Third, its specific generative algorithm. And finally, the 2-dimensional pattern plan that is used in the design. First, this study presents thus a global analytical study that drives a generative system to construct Muqarnas, through a careful balance of four specifications. In this second step, the paper reports the result of using a parametric tool, Grasshopper and parametric plugins, for creating a generative system of several types of Muqarnas. This synthetic translation aims at expanding our understanding of parametric analysis and synthesis of traditional architecture, advancing our understanding towards using parametric synthesis towards UAV-based fabrication of Muqarnas, by taking advantage of their inherent repetition and recursion.

Keywords: *Muqarnas, Iranian-Islamic Architecture, Generative System, Parametric Architecture, UAV*

ملخص. تقترح هذه الدراسة استخدام DfMA (من التصميم إلى التجميع) مبنية عن مركبة جوية بدون طيار (UAV) وتستخدم المقرنس الإيرانية الإسلامية كدراسة حالة نظرا إلى قابلية إضافة وحدات هندسية. وفي المعمارية الإسلامية، تشتهر المناطق الجغرافية المختلفة باستخدام أساليب التصميم والبناء المختلفة في المقرنس. هناك أربع مواصفات رئيسية للمقرنس لتحديد الفئة التي تنتمي إليها؛ الأول، شكله الثلاثي الأبعاد، والذي يوفر الحجم. ثانيا، حجم نماذجها

متغير. ثالثاً، الخوارزمية التوليد المحددة. وأخيراً، خطة النمط الثنائي الأبعاد التي تستخدم في التصميم. أولاً، تقدم هذه الدراسة دراسة تحليلية عالمية تدفع إلى نظام تكاثري لبناء المقرنس، بتوازن دقيق بين أربع مواصفات. في هذه الخطوة الثانية، تنشر الصحيفة نتيجة استخدام أداة البارامترية، جراسهابر و بلاكينها، لإنشاء نظام تكاثري من أنواع عديدة من المقرنس. وتهدف هذه الترجمة التركيبية إلى توسيع فهمنا لتحليل المعمارية البارامترية، التي فابريكشن مبنية عن UAV باستخدام تكرار للمقرنس التقليدي.

الكلمات المفتاحية: المقرنس، المعمارية الإيرانية الإسلامية، المعمارية البارامترية، مركبة جوية بدون طيار.

1.Introduction

The paper presents a study on parametric analysis of the Iranian-Islamic Muqarnas and analyses its components, geometric relations and construction methods that should be considered when constructing one. This study aims to use Muqarnas a driver to generate a DfMA base on the UAVs and parametric fabrication.

Muqarnas are one of the most ornamented vault types, considered one of the archetypal forms of Islamic architecture. Muqarnas were invented in the early 10th century and they have changed a lot over time in terms of design and construction methods in different geographical areas, from east of Asia until Spain and west of Africa (1). Muqarnas is considered as a complex kind of decorations that initially, aim to generate three-dimensional facades involving shadow and light and create unparalleled lines, and secondly to develop more surfaces to apply more micro decorations (2).

In Islamic architecture, different geographic regions use various design and construction methods of Muqarnas. There are four main parameters of the Muqarnas that define their classification; first, their three-dimensional shape, that provides volume. Secondly, the size of their modules is variable. Third, their own specific generative process-algorithm, and finally, the 2-dimensional pattern plan that is used as a basis in the design. We present thus a global analytical study that drives a generative system to construct Muqarnas, through a careful balance of the four parameters.

In the first step, this paper reviews studies on traditional Muqarnas (both Iranian and non-Iranian) and relevant parametric approaches. In the second step, the study aims to create a general generative system for Muqarnas. The creation of a generative system for Muqarnas is driven towards the creation of three-dimensional fabrication of their components so that these are assembled automatically using a swarm of UAVs. This particular drive imposes specific constraints in the parametric system, as the assembly of the final components, we posit, can only take place in a pick and place fashion.

2. Background

In Iran, there are some initial examples of Muqarnas before the Arab invasion to Iran (651 AD). These examples are mostly known as decorative elements. The oldest ones probably left from the *Median* era (5th century BC). *Dokan Davood*, *Sakavand Rock Tombs* and the *Tomb of Davood Dokhtar* can be named as oldest examples of Muqarnas in Iran. The first example of Muqarnas, which is very close to 16th century Muqarnas, was built in the *Masjid Jam-e Shiraz* and belongs to the *Safavid* dynasty (ninth century AD). However considerable development of Iranian Muqarnas starts from the *Seljuq* dynasty (10th century AD). From that period until now, Muqarnas construction has continued and during the 15th to 16th AD centuries, the most complex Muqarnas in Iranian architecture had been formed (3).

One of the oldest Muqarnas studies was conducted by the astronomer and mathematician *Jamshid Kashani (Al-Kashi)* in the 14th and 15th century. *Al-Kashi* explains about the applied mathematics in the book *Meftah-o Al-Hesab* (1420). In chapter 9, *Al-Kashi* describes geometric rules and relations that can be used to design and construct a Muqarnas (4). The table below reviews the various viewpoints on Muqarnas:

TABLE 1 Viewpoints on Muqarnas

Researchers	Source	Viewpoints
Abbas Zamani	Muqarnas, decoration in Islamic historical monuments of Iran, 1966	In this research, Muqarnas is divided into four categories: 1. Muqarnas at concave surfaces 2. Muqarnas in the quarter dome 3. Muqarnas in horizontal and vertical tiers, 4. beehive shape Muqarnas. In each of the four cases, it has been introduced as a decorative element.
Titus Burckhardt	The foundations of Islamic art, 1980	Muqarnas is a special phenomenon of architecture and a structure to transfer the weight of the dome to its square base. Muqarnas reflects celestial motion to the terrestrial. (functional and aesthetic aspects)
Donald Newton Wilber	Iranian-Islamic Architecture: The Ilkhanate, 1981	Muqarnas is a decorative element and it is defined for filling a concave area or surface with two or more quarter dome shapes in which each row is further forward than the row below.
Mahdi Makinejad	Muqarnas tiling in Iranian architecture, 2015	At the beginning, this element had a structural role and was used to fill the corners, but over time, in addition to the structural function, it also took on a decorative role.

2.1. PARAMETRIC APPROACHES

In 2004, *Takahashi* classified the Muqarnas, based on their plane design (e.g. square). For example, Muqarnas in Andalusia and North Africa (called Moroccan-Andalusian Muqarnas) are known as square-shaped cells (5). This

classification could not apply for Iranian-Islamic Muqarnas. Although, the Iranian style is also based on a 2D plan, however each 2D pattern could make several different 3D shapes. In Iranian-Islamic Muqarnas, the factors in dimension Z could be varied, but in *Takahashi* classification, Moroccan-Andalusian Muqarnas is characterised regardless of third Dimension. *Mohammad Yaghan* has studied a lot in terms of regeneration Muqarnas with CAD systems (6) and decoding historical muqarnas patterns (7). Although these studies can be used to reconstruct the old Muqarnas, according to the *Mohammad*, his approaches cannot design new ones (8).

Nader Hamekasi has invented a parametric strategy to model the Muqarnas. His strategy is based on using the b-spline curves. In this strategy, Muqarnas 2D pattern plane is divided into its layers and transfer into the different levels, considering the concave surface behind (9).

2.2. MUQARNAS COMPONENTS

This study aims to inspire traditional Muqarnas to generate parametric ones. Iranian-Islamic Muqarnas consist of different types of components that achieving a deep understanding with componentisation the muqarnas would help us to redefine its structure, parametrically.

In general, Iranian-Islamic Muqarnas consist of 8 main components; *Shamseh*, *Taseh*, *Toranj*, *Shaparak*, *Parak*, *Tee*, *MooshPa* and *Takht*. Also, Muqarnas includes many other components like *Madani*, but these 8 components have been used more than others so far (4).

2.3. MUQARNAS SHAPE

Iranian-Islamic Muqarnas can be classified into the 4 categories in terms of shape; *Jolo Amadeh* (means Come forward), *Rooy-E-Ham Rafteh* (means to overlap), *Moalagh* (means hanging), and *Laneh Zanboori* (means Beehive shape). Also, there are other types of classification of Iranian-Islamic Muqarnas, such as: based on materials, based on geometry, based on ages, etc.

1. ***Jolo Amadeh:*** This kind of Muqarnas is built by carving the stone and It has moderate stability. It's very simple geometrically and usually doesn't have any additional decoration. It has a very heavyweight and is made in the interior or exterior surfaces of the building.
2. ***Rooy-E-Ham Rafteh:*** After caving the stone, additional decorations are attached. decorations are made of materials such as plaster, stone and brick. This type of Muqarnas is like the *Jolo Amadeh*, but with more complexity in decoration and it has moderate stability either.

3. **Moalagh:** Its shape is similar to stalactites and is formed by attaching various materials such as plaster, tiles to the inside of the concave surface. This type of Muqarnas looks dangling and it doesn't have high stability.
4. **Laneh Zanboori:** It looks like small hives stacked on top of each other and it has a lot of similarity with *Moalagh*. (3)

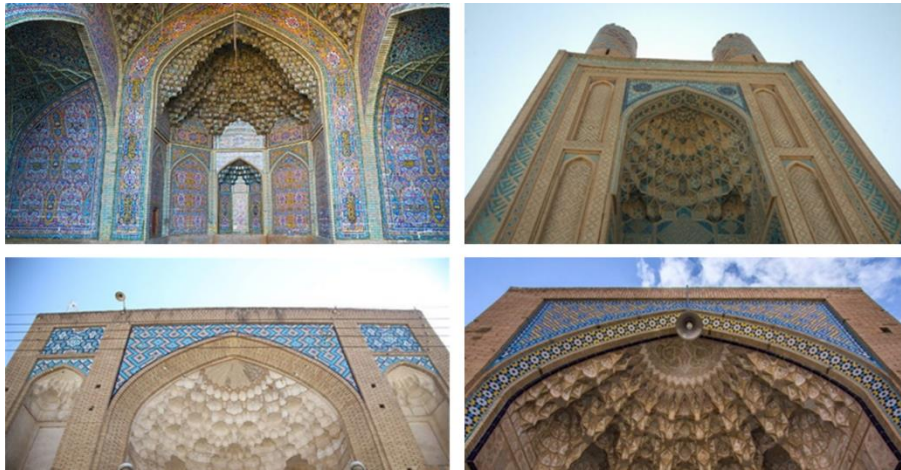

Figure 1. Bottom Left: Shrine of Fatima Masumeh, Jolo Amadeh – Top Right: Oshtorjan Mosque, Rooy-E-Ham Rafteh – Bottom Right: Agha Bozorg Mosque, Moalagh – Top Left: Nasir Molk mosque, Laneh Zanboori

2.4. TRADITIONAL CONSTRUCTION METHODS

Iranian-Islamic Muqarnas traditionally are built in three ways. There exist some other construction methods, but these three methods are most common between the traditional architects thus forming an a-typical cannon:

1. **Superimposed (*Barikeh-e Tagh*):** In this method, first, concave surfaces are built to support the Muqarnas elements. Then the elements are put on the surfaces so that there is no space between the Muqarnas and surface. In this method, the supporting surface named *Posht Band* that means to support from the back (10).
2. **Suspended Layer (*Takhteh Gachi*):** In this method with the help of the 2D patterns plan, patterns' cells are built in the ground then move to the different levels and combined with the architectural structure. Afterwards, each Muqarnas is attached to its relevant elements (11). In this method, there is a space between the Muqarnas and structure (10).

3. **Corbeled Muqarnas (*Aviz dar*):** In this method, Muqarnas is carved from stone or wooden blocks. The Muqarnas elements are carved from the middle of the dome (or vault) to the outlines (10).

2.5. MUQARNAS GEOMETRY

Decorations in Islamic architecture are inspired by Islamic philosophical concepts and mathematics plays an important role to convey these concepts (12).

The oldest classification of Muqarnas has done by *Jamshid Kashani* (Persian astronomer and mathematician, 14th and 15th century). *Al-Kashi* divided the Muqarnas, based on the 2D pattern plan and 3D geometry, into 4 categories. This classification has been used for several decades by traditional architects (13).

1. **Simple Muqarnas:** It's a kind of Muqarnas in which lines are drawn instead of curves and cells are repeated. In the 2D pattern plan, only two shapes, square and rhombus, are used. Half-square and half-rhombus might be used too. Also, all cells' sides are in the same length.
2. **Stretched Muqarnas:** The height of each level of the Muqarnas could be different.
3. **Curvy Muqarnas:** This kind of Muqarnas looks like the simple Muqarnas in the 2D pattern. But in the three-dimensional shape, curves are also used.
4. **Shirazi Muqarnas:** In this type of Muqarnas, other types of polygons are used in the 2D pattern. polygons such as triangle, pentagon and hexagon, octagon and polygonal stars.

Also, in this classification, each Muqarnas niche consists of 5 main components (14).

3. Parametric Strategies

In traditional Iranian architecture, 2D patterns always play the main role to design and construct a Muqarnas (13). To create a generative system, this study initially develops parametric strategies to create a 2-dimensional pattern plan (2DPP). on one hand, this 2DPP would help us to have an outline of modules 3D shapes and on the other hand, 2DPP can show us the right placing of the modules and guide us to generate assembly methods.

3.1. PARAMETRIC 2DPP

Several traditional patterns have been examined in terms of digitalisation and finally, the pattern *Shamseh* has been chosen, as it is a better fit for modular production. Although *Shamseh* (or Islamic star) is present in many post-Islamic historical monuments in Iran, but in this research, the two-dimensional pattern of Isfahan Mosque (*Masjid-i-Jame*) has been analysed.

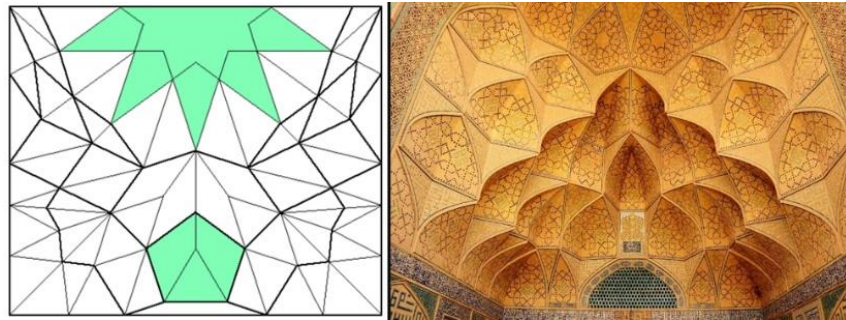

Figure 2. Masjid-i-Jame Isfahan (Source: tishineh.com)

To create a parametric 2D plan inspired by *Shamseh* pattern that used in the *Majid Jame*, the idea is creating several points toward two vectors. These points will be used to create 2 polylines. X-axis and the rotated X-axis are used. The angle used to rotate the axis is obtained by dividing a numeric variable by 360. The numeric variable would be the number of requested niches to have in 360 degrees. The point 0,0,0 is used to move and create several points. To create two polylines, the last point and first point have been ignored and two polylines are created. Then with the command 'rotation', a complete pattern would be created. The number of rotations is as same as a numeric variable in 360 degrees.

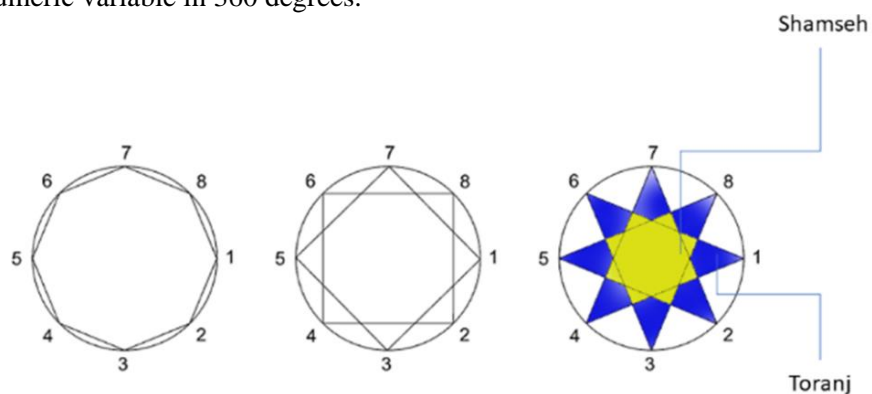

Figure 3. Islamic Star pattern is one of the most used patterns in Iranian-Islamic architecture decoration. In Persian architectural literature, Islamic star named Shamseh and each Shamseh is surrounded by several Toranj.

3.2. PARAMETRIC 2DPP

As mentioned, several parametric strategies have been compared in terms of digitalisation produce. To understand the procedural difference of the strategies, finding algorithm bugs and gaps, 11 done parametric sketches have been reviewed and compared. Advantages and disadvantages of each digital strategy, in the point of view of the fabrication feasibility and UAV based assembly, the possibility of adding joints and structure of components have been assessed. Finally, the strategy below has been selected to be used to be assembled by UAVs.

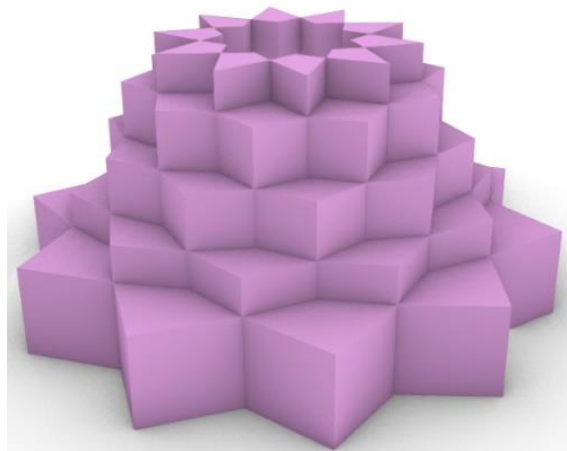

Figure 4. A complete dome made by parametric modules

Each mould should be extracted from its specific unit in the designed parametric pattern. After creating Muqarnas pattern (and before 360-degree rotation), the units in the pattern must be separated to turn to separate surfaces. Then, the surfaces are extruded to turn to the volumes (or modules). The height of modules can be the same or vary, in this study, the same height is used. Each module transfers to its defined level. The height of the modules is used, to define the levels. For example, the height of the third floor will be the sum of the heights of the first and second floors' modules (mass addition). However, to add the joints, an overlap is needed to add between two top and bottom modules. To do so a formula has been created to specify each modules level ($2h+10$; h is the height of the modules). This formula can be changed for other types of modules or structures. After putting the modules in the appropriate levels, they should have arrayed them to have a complete dome.

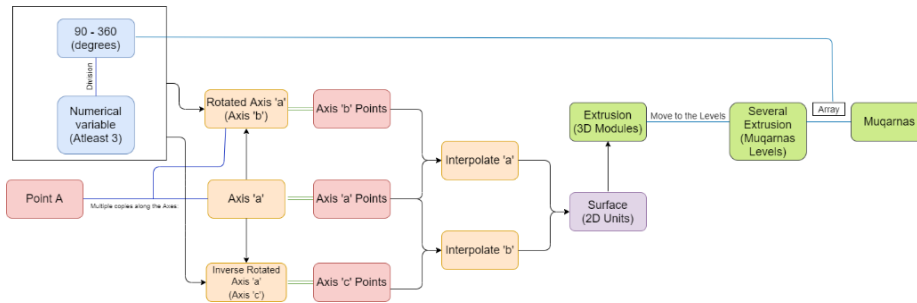

Figure 5. Illustration of final algorithm

4. Structural Design

As discussed, the Muqarnas is known as the decoration and traditionally doesn't play any structural role, but in this study, as the aim is to use Muqarnas as the vault, the structure has been optimised to have an independent Muqarnas standing on its own weight. To keep the structure and proper weight transfer, the modules are optimised in terms of joints and shape. This optimisation makes the modules spread their load to the modules below.

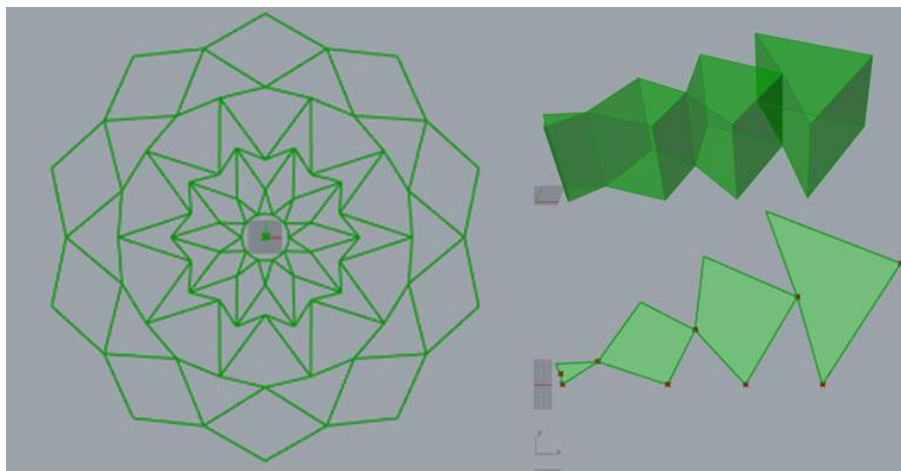

Figure 5. Each mould should be extracted from its specific unit in the designed parametric pattern.

4.1. MODULES' SIZE

This parametric Muqarnas has 5 rows and due to the nature of Muqarnas, each row has its specific components in terms of size. (In the traditional Muqarnas the shapes don't change but size becomes smaller from bottom to

PARAMETRIC IRANIAN-ISLAMIC MUQARNAS AS DRIVERS FOR DESIGN FOR FABRICATION AND ASSEMBLY VIA UAVS

top. But in our study, the components' shapes become a little bit different, although the difference is not obvious after assembly). So, this parametric Muqarnas has 5 sets (more levels can be added) of shapes and sizes and modules get heavier and bigger from bottom to top. The number of modules in each row are the same and can be changed parametrically.

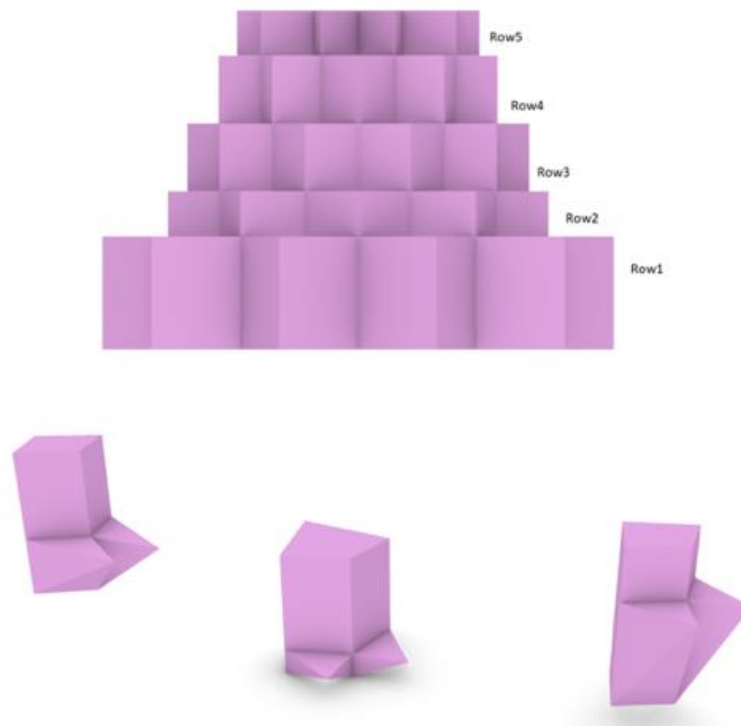

Figure 6. Modules' shapes are varied in each row

4.2. BACKREST

In this study, each module is transferring the weight of itself and modules above to the modules below. In traditional Muqarnas, particularly in complex and Shirazi types (in Al-Kashi classification), the arcs and triangle shape components can be seen below each mould. Usually, this is known as tile decoration and doesn't have any structural role but in our Muqarnas, it has been inspired for structural consideration.

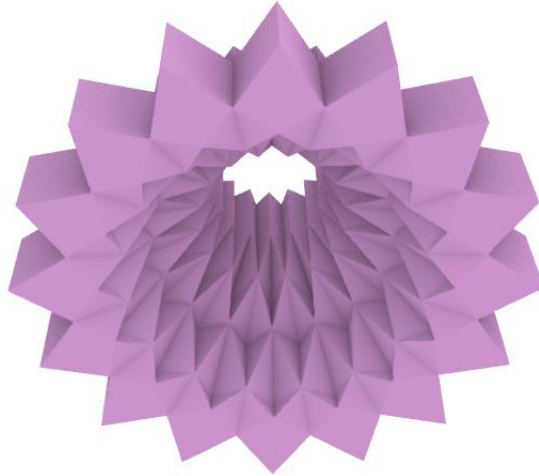

Figure 7. Backrest: inspired by the traditional decoration

Each Muqarnas has two backrests on both sides that provide enough spaces for the two moulds above. In this way, each module is supported by both the side modules and the bottom modules. Also, it could provide an overlap surface between two modules which allows adding more joint for large scale and different materials.

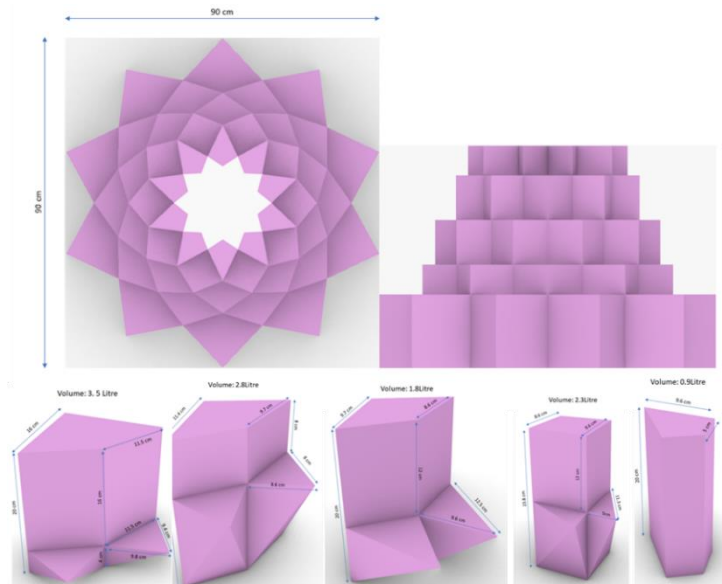

Figure 8. This Muqarnas includes 5 types of modules (5 rows). Modules' sizes get smaller from the bottom up.

4.3. UAV-BASED ASSEMBLY: PROPOSED ASSEMBLY SKETCH

Modules assembly will be carefully analysed in the next part of the research and will be reported in another paper. However, in this paper, a sketch is proposed to be examined under scale. The proposed assembly strategy aims to use a board that the first-row pattern should be carved on it.

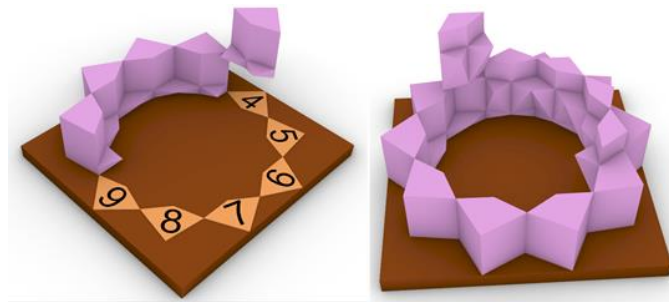

Figure 9. The border of the first row's components would be drawn on a board and programmed drone will put the first set of components on relevant units. Then, the components will be put on above each other, row by row.

Drone should pick each module from the picking site. In the picking site, components would be placed with the right orientation. Picking site will be helpful to lead the programmed drones and minimise the drone flying distance and rotation.

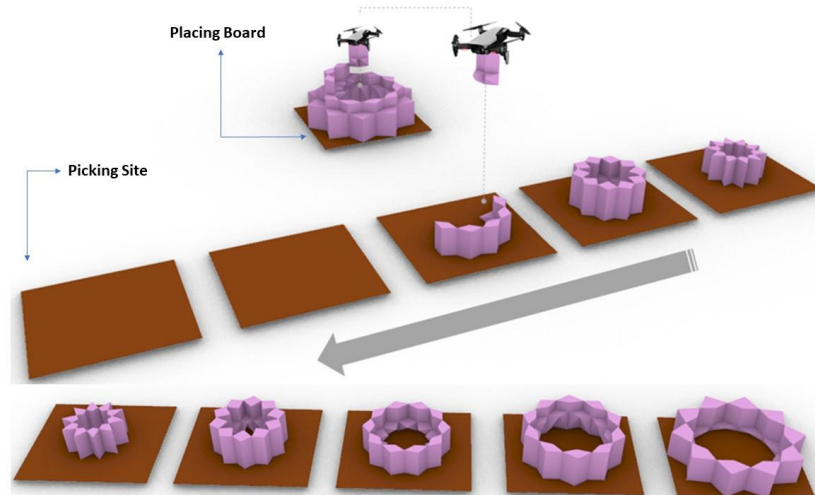

Figure 10 Placing Board and Picking-site: Each board in picking-site would be moved after picking up all its modules.

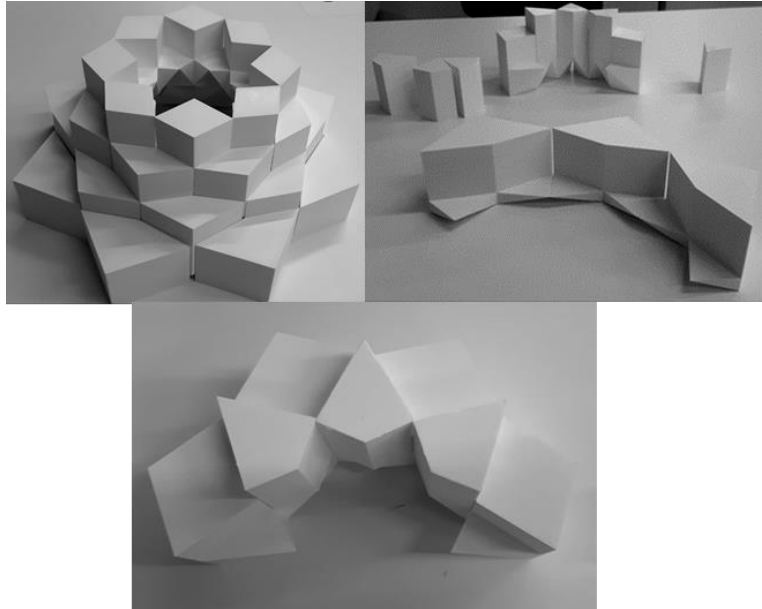

Figure 11 The modules have been 3d-printed under 1/3 scale to test the structure resistance and have been assembled.

5. Conclusion

In the first stage, this paper focused mostly on the analysis and extraction parametric features of the Iranian-Islamic Muqarnas and its encoding into a modular system. In the second stage, this paper formulated a parametric generative production and then tested an assembly strategy under the scale.

The parametric algorithm introduced in this paper could generate a diverse variety of designs of Muqarnas. Although Muqarnas traditionally is considered as the decorative element, but this study considers the four main specifications mentioned below to define the parametric Muqarnas as a structural element:

1. Volume (length, width and height),
2. Scale,
3. algorithm,
4. two-dimensional pattern plan.

The main advantage of this methodology is that all four mentioned specifications can be changed parametrically.

This study analysed generativity the feasibility of the design and production of Muqarnas modules. Mentioned picking and placing technique, from above, would be helpful to generate an assembly model based on UAV. The parametric design causes the modules to have a reliable structure. This parametric approach can be potentially expanded to other DfMA strategies.

Also, the proposed methodology of this paper could be used to analyse the vernacular architecture, parametrically. This vernacular synthesis would be helpful to redesign the vernacular architectural shapes and create modular generative systems from them. It should be considered that this UAV-based DfMA is still under progress. In the next phase, additional structural testing will be analysed. After ensuring the strength of the structure (in particular, lateral forces analysis) and assembly model efficiency, the programmed UAVs would be examined to make a complete Muqarnas under the scale.

References

1. Kazempour, H. (2014). Iii, The evolution of muqarnas in Iran from pre-Seljuk to ILKhanid period. [online] Available at: <http://eprints.utm.my/id/eprint/78066/1/HamidrezaKazempourfardPFAB2014.pdf>.
2. Alaçam, S., Güzelci, O.Z., Gürer, E. and Bacinoğlu, S.Z. (2017). Reconnoitering computational potentials of the vault-like forms: Thinking aloud on muqarnas tectonics. *International Journal of Architectural Computing*, 15(4), pp.285–303.
3. Govabari, M. and Ghalamara, S. (2018). Analysis of Muqarnas art in historical periods before and after Islam in Iran and the extent of the spread of this art in the world. [online] Tehran: Memarishenasi Journal, Number 5. Available at: <http://ensani.ir/file/download/article/1550384077-10149-5-10.pdf>.
4. Kashani GADJ. Meftah al Hesab, Revised by Adamerdanes & Asheikh, Cairo, Dar al Kitab al Arabi Atab va Nashr, 1967. & Britanisky LS, Rosinfied B. Ghais al din Jamshid Kashani, Azerbaijan Art, 5, 1956.
5. Senhaji, M. and Benslimane, R. (2019). Automatic 3D muqarnas architectural patterns reconstruction using plane representation. *Journal of Cultural Heritage*, 35, pp.25–40.
6. Yaghan, M.A.J. (2003). Gadrooned-Dome's Muqarnas-Corbel: Analysis and Decoding Historical Drawings. *Architectural Science Review*, 46(1), pp.69–88.
7. Yaghan, M.A.J. (2000). Decoding the Two-Dimensional Pattern Found at Takht-i Sulayman into Three-Dimensional Muqarnas Forms. *Iran*, 38, p.77.
8. Yaghan, M.A.J. (2001). The Muqarnas Pre-designed Erecting Units: Analysis, Definition of the Generic Set of Units, and a System of Unit-Creation as a New Evolutionary Step. *Architectural Science Review*, 44(3), pp.297–318.
9. Hamekasi, N. (2013). Interactive Design of Muqarnas. *prism.ucalgary.ca*. [online] Available at: <http://hdl.handle.net/11023/441> [Accessed 9 Sep. 2020].
10. Hamekasi, N., Samavati, F.F. and Nasri, A. (2011). Interactive modeling of Muqarnas. *Proceedings of the International Symposium on Computational Aesthetics in Graphics, Visualization, and Imaging - CAe '11*.
11. Kazempour, H., (2016). *The Evolution of Muqarnas in Iran*. Reseda, La: Supreme Century, pp.7–8.
12. SWINFORD, D. (2019). The Muqarnas: A Key Component of Islamic Architecture | *Encyclopedia.com*. [online] *Encyclopedia.com*. Available at: <https://www.encyclopedia.com/science/encyclopedias-almanacs-transcripts-and-maps/muqarnas-key-component-islamic-architecture>.
13. Mohammadian, S. and Faramarzi, S. (2013). Investigation of the existence of quasi-periodic order in the geometric structure of the Patkaneh. [online] *Honar hay-e Ziba Journal (Fine Arts University)*. Available at: https://jfaup.ut.ac.ir/article_50533_69a27da7b9ae5e4a47fd636e2e38f86a.pdf [Accessed 28 Aug. 2020].
14. Gherardini, F. and Leali, F. (2016). A Framework for 3D Pattern Analysis and Reconstruction of Persian Architectural Elements. *Nexus Network Journal*, 18(1), pp.133–167.

THE CUSTOMIZED HABITAT

An Exploration of Personality-induced Mass Customization through Shape Grammars

AHMED MAREY, AHMED BARAKAT

The American University in Cairo, 5th Settlement, Cairo, Egypt

Email address: ahmedmarey@aucegypt.edu

Franklin & Marshall College, Lancaster, Pennsylvania, USA

Email address: abarakat@fandm.edu

Abstract. Despite its economic efficiency, mass production fails to appeal to the very people it is meant to accommodate. Mass customization, on the other hand, allows for the consideration of personal differences. Nonetheless, it is a process that requires more time, effort, and resources, hence the reliance upon mass production. Previous research showed a potential impact of personality on perceptions of the architectural space. The research investigates the applicability of mass customization in the architectural domain using MBTI (Myers–Briggs Type Indicator). Using MBTI, we surveyed 187 individuals to investigate the correlations between personal traits (mind, energy, nature, tactics, and identity) and preferences of architectural aspects (exposure, circulation, view, plan layout, and interior colors). The survey draws on how multiple fields have successfully applied MBTI to increase the value they provide. The findings present a novel contribution to architectural research as they demonstrate an actual connection between MBTI personality patterns and architectural preferences. In addition to several interaction patterns, our results strongly support an effect of the mind aspect on view preferences as well as an effect of energy on three architectural aspects: view, plan layout and interior colors. Shape grammars were then created, based upon these correlations, in order to provide a basis for optimized mass customization. The optimization/automation of this process will result in a more habitable space in which neither personality differences nor valuable resources are sacrificed.

Keywords: *Mass Customization; Personality Traits; Shape Grammars; Architectural Perception.*

THE CUSTOMIZED HABITAT: AN EXPLORATION OF PERSONALITY-INDUCED MASS CUSTOMIZATION THROUGH SHAPE GRAMMARS

ملخص. على الرغم من كفاءته الاقتصادية، إلا أن الإنتاج الضخم يفشل في جذب نفس الأشخاص الذين من المفترض أن يتم استهدافهم. من ناحية أخرى، يسمح التخصيص الشامل بالنظر في الاختلافات الشخصية. ومع ذلك، فهي عملية تتطلب المزيد من الوقت والجهد والموارد، وهو ما يفسر الاعتماد الحالي على الإنتاج الضخم. أظهرت الأبحاث السابقة تأثيراً محتملاً للشخصية على تصورات الفضاء المعماري، لذلك يدرس هذا البحث قابلية تطبيق التخصيص الشامل في المجال المعماري باستخدام MBTI (مؤشر نوع مايرز بريجز). باستخدام MBTI، قمنا بمشاركة استطلاع مع 187 شخصاً للبحث في العلاقات بين السمات الشخصية (العقل، والطاقة، والطبيعة، والتكتيكات، والهوية) وتفضيلات الجوانب المعمارية (التعرض، والتداول، والمنظر، ومخطط الأرضية، والألوان الداخلية). تقدم نتائج الاستطلاع مساهمة جديدة في البحث المعماري لأنها توضح وجود صلة فعلية بين أنماط شخصية MBTI والتفضيلات المعمارية. تدعم نتائجنا بقوة تأثير الجانب العقلي على تفضيلات المنظر بالإضافة إلى تأثير الطاقة على ثلاثة جوانب معمارية: المنظر ومخطط الأرضية والألوان الداخلية. لذلك تم إنشاء القواعد التشكيلية، بناءً على هذه الارتباطات، من أجل توفير أساس للتخصيص الشامل الأمثل. سيؤدي تحسين هذه العملية إلى خلق مساحات صالحة للسكن لا يتم فيها التضحية بالاختلافات الشخصية أو الموارد القيمة.

الكلمات المفتاحية: التخصيص الشامل؛ سمات الشخصية؛ القواعد التشكيلية؛ تصور الفضاء المعماري

1. Introduction

Shape grammars are generative structures based on rules that allow designs to be captured, developed, and understood. They are based on Emil Post's (1943) production systems and Noam Chomsky's (1957) generative grammar. Instead of symbolic computations (Knight, 2000), shape grammar primarily deals with shape computations, in which a shape is defined as a predefined number of maximal lines (Stiny, 1980). Designs are generated by recursively applying a series of rules to an original form until a design is finished or no further rules can be implemented. In brief, it is possible to add many rules to any particular shape, thus creating several different designs. The rules can be directed towards many applications or based on different ideologies. However, in this paper, we are proposing the use of shape grammars in the architectural domain in order to accommodate different personality types in which the rules are based on psychological traits and how each personality type perceives space. Gorbman and Shemesh (2015) have examined a similar idea in which they explored how humans perceive different geometries. Although there was a general theme for each geometry, they were unable to explain some noticeable differences between different groups. In this paper, we hypothesize that those differences were because of different personality types.

The built environment is subject to the interpretations and perceptions of human experience. These perceptions and interpretations are susceptible to change based on the person. It is also plausible to conclude that one's personality affects their perception of the architectural space (Ibrahim, Abu-Obeid & Al-Simadi, 2002). Since the architectural space could also have a "personality" - formed by the complex relationship between the physical

elements and their effect on people, "architecture could be best defined as the dynamic interaction of space and personality" (Moller, 1968).

Since the beginning of time, psychologists have formulated rough ideas to identify and categorise different personalities. They have been motivated to incorporate the variables and dynamics of human personality with well-defined models, from the four temperaments by the Greek physician Hippocrates to the new developments in psychology such as Myers-Briggs theory. Even though the current models still cannot comprehend the complexity of our personalities, they account for the most critical aspects and can forecast our actions with a high degree of precision. The approach we are adapting in this paper is an integration between two different philosophies. This first one is Jung's theory of psychological types (1921), which is considered the most prominent creation in personality typology, and influenced many other theories. Jung's first main contribution is the development of the "Introversion and Extraversion" idea, theorizing that each one either focuses on the inner world or the outer one. The second contribution is the cognitive functions concept, categorizing people into either judging or perceiving traits. Each one adapts one of these cognitive functions, according to Jung, and can rely on it more naturally in everyday life. Katharine Cook Briggs, who later co-authored the Myers-Briggs Type Indicator (MBTI), noticed Jung's theory in the 1920s. Before knowing about Jung's work, Briggs was an educator with an avid interest in temperament modeling, having established her own personality theory. They created a practical way to explain the order of each person's interests, which will be adapted in this paper.

2. General Description of the Mass Customization Process

The ideology of mass customization has recently adapted and developed in the business community. However, its effect in the engineering field has not been highly investigated. Without a resulting rise in cost and delivery times, mass customization seeks to provide client satisfaction with increasing diversity and customization. Instead of the old model of industrial production to mass-produce standardised goods by economies of scale, it focuses on economies of scope (Pine, 1993). The economics of mass customization are demonstrated in figure 1. The volume is adequate for high volume manufacturing to defray the expense of expenditure in machinery, tooling, engineering and others. Mass production indicates an edge distinctly. However, consumers are able to spend more when their specific interests are met in low to medium volume production where the production quantity does not warrant the expenditure.

THE CUSTOMIZED HABITAT: AN EXPLORATION OF PERSONALITY-INDUCED MASS CUSTOMIZATION THROUGH SHAPE GRAMMARS

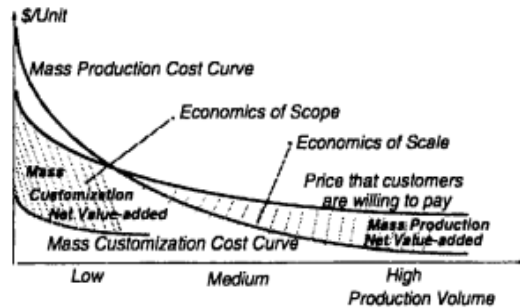

Figure 1. The economics of mass customization.

Since mass production failed to appeal to the people it is meant to accommodate, mass customization is proposed in a feasible manner to personalize housing units. Here we aim to investigate different shape grammar rules based on different personalities to achieve mass customization. An algorithm was developed throughout a direct framework in which MBTI personality type is fed into, rules are applied to a basic shape, and output a housing unit customized to this personality type (Figure 2).

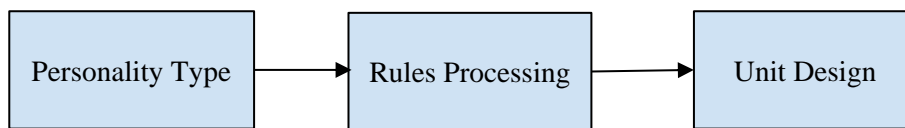

Figure 2. Customization Process.

2.1. SHAPE GRAMMAR RULES

After the initiation stage, there are five different stages that take place in order to reach the final outcome. Each stage corresponds to one of the five architectural aspects that we decided to tackle (plan, design, colors, exposure and view) and has two rules. The initiation stage draws a box representing the housing unit, in which the corner is at (0,0,0) in the Cartesian coordinate system with length, width and height of a, b and c (defined by the designer) respectively. It should be mentioned that the box here is treated as a set of surfaces connected with vertices, and any change in the vertices will result in a change in the faces relating to them. The plan stage starts by an addition operation to the four vertices of one face in the perpendicular direction to the surface (Rule 1), which will result in elongating the plan, or in the parallel direction (Rule 2), which will result in bending the plan. The second stage constructs the internal walls of the housing unit by identifying different points on opposite external walls and connecting them with straight walls (Rule 3)

or applying other points in the space between the two external walls to create curved walls (Rule 4). Thereafter, the color stage takes place to identify the paint used in the interior walls. This is computationally designed by identifying the range of pastel colors (Rule 5) vs. the range of deep colors (Rule 6) in the RGB spectrum, and applying them to the pre-constructed walls in the previous stage. The previous three stages are focused on the relation between the inhabitants and the interior of their housing units. The last two stages are concerned with the relationship between the inhabitants of those units and the outside environment. The following stage first identifies the one of the two larger sides of the housing and offset its edges by a certain factor to create a small window opening (Rule 7) or a large curtain wall facade (Rule 8). The final stage rotates the whole housing unit around the origin in the x-y plane to either give it an urban view or a nature view. An elaboration of the multiple rules and variations is illustrated in Table 1 and Figure 3.

TABLE 1. Simplified Shape Grammar Rules.

Rule 1	Rule 2	Rule 3	Rule 4	Rule 5
Elongate Plan	Bend Plan	Draw Straight Interior Walls	Draw Curved Interior Walls	Apply Deep Colors
Rule 6	Rule 7	Rule 8	Rule 9	Rule 10
Apply Pastel Colors	Apply Small Opening	Apply Curtain Wall Facade	Orient Towards Nature	Orient Towards Urban

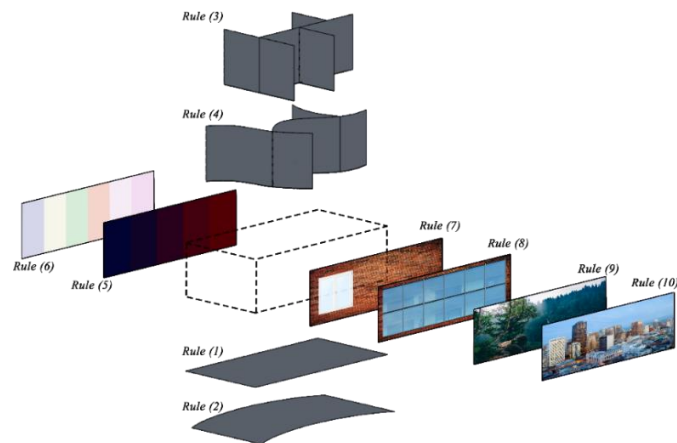

Figure 3. Shape Grammar Rules

THE CUSTOMIZED HABITAT: AN EXPLORATION OF PERSONALITY-INDUCED MASS CUSTOMIZATION THROUGH SHAPE GRAMMARS

2.2. CUSTOMIZED HABITAT DESIGN

The customization process might only be dependent upon the different personality types fed into the algorithm. However, to make the proposed project feasible in real life, the algorithm must meet site constraints, which are predefined before the feeding of personality types. The algorithm works within the plot area size and shape, along with the surrounding buildings or natural views, which are key aspects in our proposal.

3. Methodology

3.1. PARTICIPANTS

The participants were recruited anonymously through different social media platforms, and snowball sampling - which offers a diverse participant pool - to identify their personality type and choose their preferred architectural aspects in different sections, namely: exposure, design, view, plan and colors. Moreover, to accommodate for demographic differences, the survey was not restricted to one gender or region, rather, it aimed at collecting diverse samples to establish global rules. Originally, the target number for participants was 500. However, due to the limited time of the study, only 187 participants were able to complete the questionnaire. It took participants around 5- 7 minutes to complete it.

Considerable diversity of participants were exhibited in terms of age, gender and geographic location. Ages ranged from less than 18 to more than 65, with the majority between the age of 18 and 24. Also, the gender distribution was almost balanced with 70 males, 115 females and 2 non-binary/genderqueer (Figure 4).

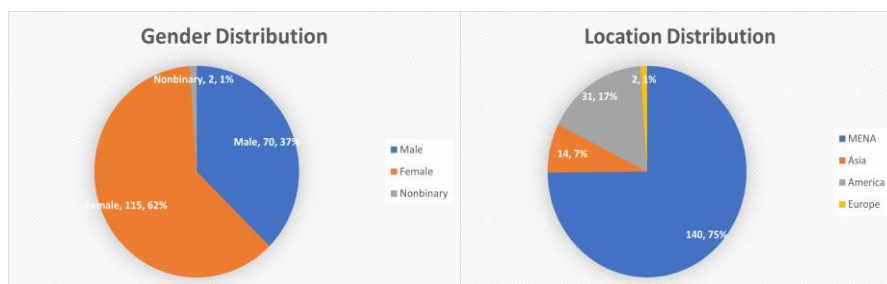

Figure 4. Demographic Distribution.

3.2. PERSONALITY TRAITS

In order to assess individuals' alignments with Myers-Briggs personality traits, participants were asked to state their individual personality patterns if they could. In addition, we included a set of 14 questions, each corresponding to certain traits. The questions allowed us to deduce where each individual fall on the spectrum pertaining to each of the five traits: mind, energy, nature, tactics, and identity. For example, if an individual's answers indicated more observance than ideation, they're more likely to be on the sensing side of energy. While if someone's responses show more decisiveness over doubt, they're probably on the assertive side of the identity trait.

3.3. MATERIALS

Since images of architectural aspects were not identical - except for the aspect tested, a brief description at the beginning of each section was given in order to make sure that participants were actively evaluating the aspect intended. The 40 images used in the questionnaire were collected from different sources, and were found using Google Images. The images were chosen based on their demonstration of the intended aspect. A board range of images were gathered to cover the most attributes and diverse views of each architectural aspect. The images used had no restrictions for reuse or modification, hence images are free of charge and can be reused without any restrictions.

Each of the selected aspects had 8 images - 4 for each side. Each section - focusing on one of the 5 aspects - had 4 questions, each asking about the frequency preference of one image over the other. The given choices ranged from *never* - passing through *rarely*, *sometimes*, *most of the time* - to *always*. The exposure section showed images of highly exposed interiors to the outside verses less exposed spaces; direct and indirect or mysterious circulation were shown in the plan section; The view section showed contrasting images between urban and natural view, which is followed by the plan section displaying images of organized plans and flexible plans. The final section was demonstrating the differences between deep colors and pastel colors to understand the appeal of each to different personality types. It is worth noting that the categorization of the images in those 10 sets has no empirical background or measurement, rather made by the first and second author merely to understand how different personalities appeal to them.

THE CUSTOMIZED HABITAT: AN EXPLORATION OF PERSONALITY-INDUCED MASS CUSTOMIZATION THROUGH SHAPE GRAMMARS



Figure 5. Survey Sample Images

3.4. PROCEDURE

3.4.1. *Prestudy*

Human decision making is not always linear. In fact, according to Imperial College London, it is not even always about facts or evidence. Different aspects of human behavior, rather than facts or evidence, have affected our decision making for eons (Hunt, 1989). As a result, prior to the beginning of the study, different personality theories were examined, and assumptions were made correlating different personality aspects to architectural aspects. Although MBTI showed some deficiencies - because of the questions formulation - compared to the Cognitive Theory (CT) for example, it was chosen since it is the most popular between different age groups and people from different geographic locations. For instance, about 13% of employers in the US now utilize the MBTI to decide which prospective employees to hire, relying on their understanding of how each component of the MBTI would affect an employee's success potential at the workplace (Hough, 2002).

It is established in psychological circles that surroundings affect the expression of different behavioral aspects (Vozarova, 2019). As a result, we founded our first assumption: individuals prefer environments that facilitate the expression of their specific behavioral patterns. This allows us to identify correlations between the 5 aspects of the MBTI and perception of architecture. Those five aspects are: Mind, Energy, Nature, Tactics and Identity. The patterns in which variations in these aspects can be combined define each personality type. The mind aspect considers the way people react to the surroundings, and whether one prefers solitary activities or social interactions. Therefore, this aspect was assumed to be related to the preferred degree of exposure to the surroundings. The second aspect is energy which considers the way a person processes information. It is concerned with one's tendency to be more practical and focuses on the moment or to be more curious and imaginative, looking for future possibilities, which is the reason it was correlated with the practicality of the circulation - direct vs. mysterious or indirect. The nature aspect was correlated with the view as it focuses on the rationality or objectivity of each individual, and how competitive or logically thinking a person is versus how they prioritize feeling or being empathetic.

The fourth aspect - tactics - categorize people into two categories: judging people who value clarity and predictability and prospecting ones who are more likely to be flexible and keep their options available. This resulted in relating this aspect with the layout plan and how they navigate inside. Finally, the identity aspect reveals how confident versus stressed or indecisive a person is, which is, therefore, related to the colors of the interior.

3.4.2. Main Study

In order to avoid participant fatigue, we had to make a few decisions about the methodology of surveying participants about their personality traits and their architectural preferences. Personality tests available online can take a very long time as they contain sometimes over a hundred questions. In this survey, participants first receive a general description of the questionnaire and what to expect, along with a choice for Arabic or English language. Second, participants fill some demographic information to understand their background. The third section asks participants, if possible, to identify their personality type according to MBTI. If they do not know their MBTI type, the survey then asks questions about the participants' personality patterns. The questions posed represent a short, adapted version of the readily available MBTI tests. Every few questions over the following five sections of the survey aim to at determining one of the 5 components of each person's personality type. We later interpret the personality patterns data to assume each participant's MBTI type.

4. Results and Analysis

4.1. UNIVARIATE DISTRIBUTIONS

Participants showed considerable variation in different personality aspects (Figure 6).

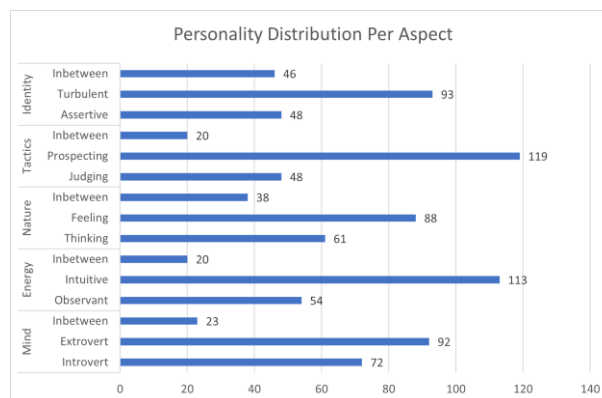

Figure 6. Personality Distribution Per Aspect

THE CUSTOMIZED HABITAT: AN EXPLORATION OF PERSONALITY-INDUCED MASS CUSTOMIZATION THROUGH SHAPE GRAMMARS

The multiple choices in the survey - architectural aspects sections - were given values from 1 (Never) to 5 (Always/Almost Always). Using four questions targeting each of the five architectural aspects, we calculated a mean score that describes the preference of each aspect. The mean scores (+/- 1 SE) were then plotted against the corresponding personality trait according to our predictions (Figure 7).

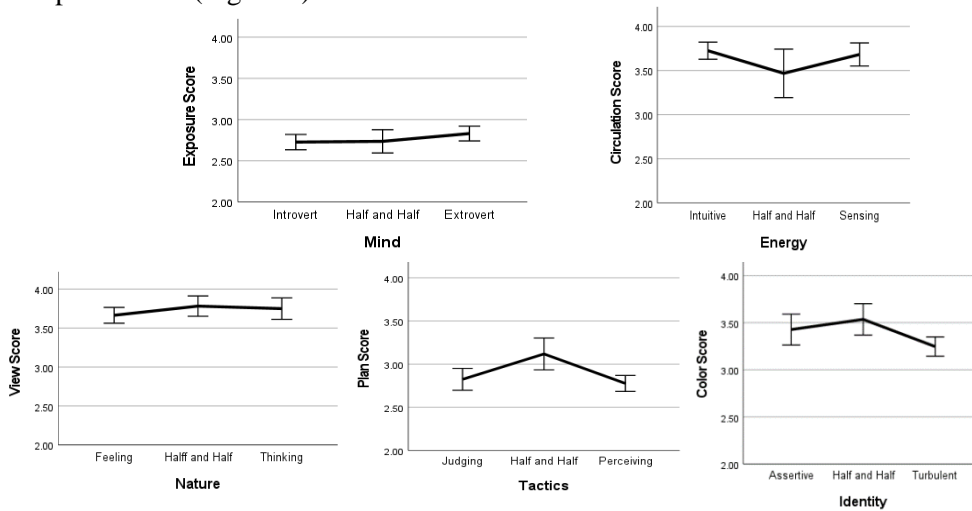

Figure 7. Mean values of personality traits in relation to pre-assumed architectural aspects

4.2. RELATIONSHIP BETWEEN ARCHITECTURAL ASPECTS AND ITS PERSONALITY TRAIT

The mean values showed NO significant correlation with the pre-assumed architectural aspects. However, a 5-way ANOVA method was implemented to investigate if there are any correlations between personality traits and architectural aspects. The results were analyzed in terms of significance (P-Value) and displayed in Table 2.

Personalities' mind (introversion vs extraversion) showed a significant difference in preferences of views between individuals who fall in the middle compared to those who fall on the extremes (Figure 8(A)). In addition, those who fall in the middle of the energy spectrum exhibited significant differences in view and plan layout preferences compared those on the extremes (Figure 8 (B,C)). Finally, intuitive individuals showed a much higher preference of deep colors compared to their sensing counterparts (Figure 8(D)).

TABLE 2. Personality Traits with Significance Correlation to Personality Aspects.

	Mind			Energy			Nature			Tactics			Identity		
	F	df	Sig.	F	df	Sig.	F	df	Sig.	F	df	Sig.	F	df	Sig.
Exposure	.219	2	.693	.962	2	.198	.107	2	.837	.129	2	.806	.461	2	.462
Circulation	.119	2	.884	.455	2	.621	.253	2	.768	.970	2	.361	1.812	2	.148
View	3.166	2	.023*	2.963	2	.029*	.208	2	.784	2.235	2	.071	.681	2	.451
Plan	.646	2	.458	4.126	2	.006*	1.056	2	.278	.937	2	.321	1.432	2	.242
Colors	.545	2	.593	4.315	2	.015*	1.111	2	.343	1.565	2	.221	1.234	2	.294

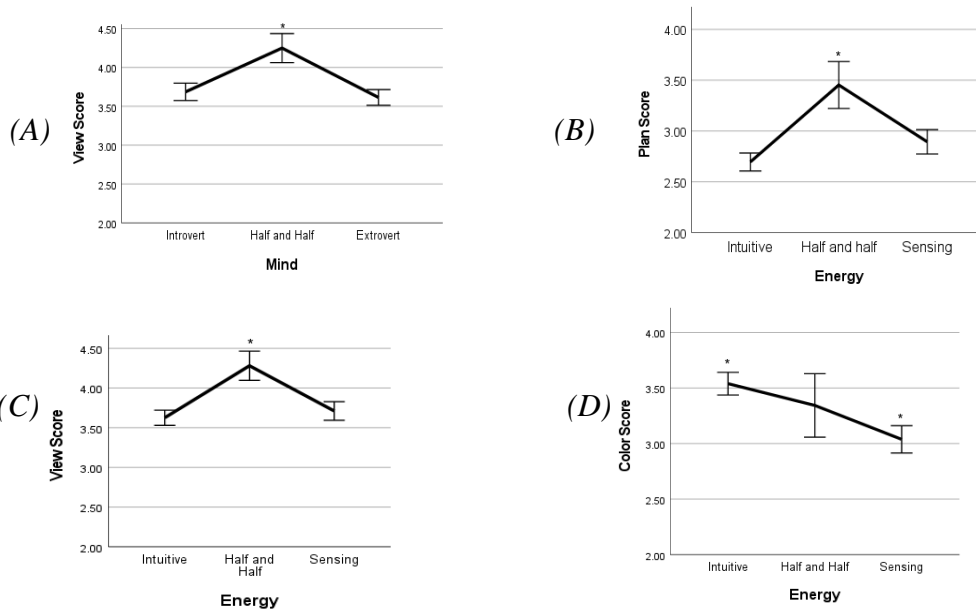

Figure 8. Mean values of significant personality traits in relation to architectural aspects

5. Discussion

Our findings failed to support any of the relationships we hypothesized between architectural aspects and corresponding personality traits. Nevertheless, the patterns we observed are unique and provide insight into

THE CUSTOMIZED HABITAT: AN EXPLORATION OF PERSONALITY-INDUCED MASS CUSTOMIZATION THROUGH SHAPE GRAMMARS

how certain personality traits could affect a person's interactions with surrounding architecture (Table 2). Specifically, a personality's energy (intuition vs. sensing) has shown significant effects on preferences pertaining to three architectural aspects: view, plan, and colors. Namely, those whose personalities fall in the middle between intuition and sensing are more likely to choose a natural view over an urban one than those who fall on either extreme. In addition, they are also more likely to choose a flexible plan in place of an organized one. Finally, those who are further on the intuitive side are more likely to select deep colors compared to their sensing counterparts.

We also observed an effect by the mind (introversion vs. extroversion) on a single architectural aspect—the view. Individuals who are ambiverts (neither introverts nor extroverts) have a larger preference for natural views over urban views in comparison to introverts and extroverts.

Despite the facts that these findings do not align with any of our predictions, they still support our claim that certain personality traits can affect people's preferences of certain architectural aspects. It is clear that a personality's energy (intuition vs. sensing) is one of these traits that can be used in assessing people's needs. Nevertheless, we observed several interactions that can provide a guide to what future research may address. We found that the interactions between mind, energy, and tactics; between mind, tactics, and identity; and between mind, nature, and identity all have significantly impacted people's exposure preferences. This further amplifies our confidence in our claims, as it aligns with our hypothesis that the mind (extraversion vs. introversion) would demonstrate an impact on exposure preferences. Similarly, our analysis showed an effect of the interaction between mind and identity on color preferences. Again, this fall in line with our original hypothesis that identity (assertion vs. turbulence) would impact the choice of color in architecture.

Technology improvement and data evaluation processes allow for a shift towards mass customization for higher customer satisfaction rates with relatively lower costs which was emphasized by Boychenko (2017). The architecture, based on the mass customization model, would vary greatly from the traditional construction design. The work on visual and structural richness and diversity is focused on radically new methods established to promote diversity and sophistication. All this is based on basic rules used to establish connections between all the building elements in the treatment of cognitive patterns (Anderson, 2004).

Mass customization is also applicable in the building industry, according to Frutos and Borenstein (2003). They showed that apartment buyers expect personalized offerings, which ensures that solutions can meet the specific desires of the consumers in order to ensure customer loyalty, which further indicated the importance of our work. Within 16 projects over 35 years, Schoenwitz et al. (2012) researched which components German home

customers wanted to configure. They recognized a deep desire to customize the sanitary, internal architecture, and façade categories. Those categories are the ones examined in this paper since they have the highest influence on people's psychological state based on their preferences. In this paper, we did not opt to a specific type of building whether high-rise or low-rise. However, since mass customization is explored as a way to achieve satisfaction with low-cost, Wang (2018) investigated the method of customizing high-rise buildings, which can be used in dense areas for a better life quality. The methods we use align with his as we both encourage mass customization at the beginning without adaptability after construction because it will be hard and expensive.

Our study is a glimpse into how individuals' architectural preferences may be assessed. Consequently, we were able to demonstrate that mass customization of architecture is possible. However, further research is crucial. A profound understanding of how demographic, social, and personal aspects (together and independently) of individuals affect their interactions with their surroundings is essential to develop shape grammars for mass customization. Mass customization has the potential to not only allow for better lived experiences but also revolutionize how architects everywhere approach their field.

6. Future Recommendations

In order for architects to develop such an understanding, it is imperative for future study designs to address personality traits as a continuous scale that goes from one end to another as opposed to our design that categorized each trait into three groups: two extremes and a "half-and-half." Approaching our independent variables as a scale shall allow future research to capture a fuller, more real image of individual variations.

Because of our approach to personality traits as categorical variables, our statistical analyses relied on a set of ANOVAs and post-hoc Bonferroni Tests. The use of ANOVA, however, is not ideal due to our data failing to demonstrate a normal distribution. However, it is important to acknowledge that our results are still completely valid as ANOVAs are not sensitive to normality unlike other parametric tests, allowing us to still make conclusions regarding non-normal data (Luh, 2001). With this in mind, we reiterate the need to approach personal characteristics as continuous variables rather than categories. In this case, ANOVAs will not be used as the main statistical tool and more robust inferences about correlative relationships can be made.

Finally, in addition to the statistical approach, we recommend paying close attention to the effects of a personality's energy (intuition vs sensing), since it is a trait we have seen affect the preferences of multiple architectural aspects. Intuitive individuals tend to focus on the meaning behind certain patterns and their impressions of an idea. On the other hand, sensing individuals are most

THE CUSTOMIZED HABITAT: AN EXPLORATION OF PERSONALITY-INDUCED MASS CUSTOMIZATION THROUGH SHAPE GRAMMARS

attentive to the details of physical reality and what triggers their five senses. As a result, energy is a trait that is most likely critical to interactions with our surroundings as demonstrated by our results as well as the Myers-Briggs theory (Grobman, 2015).

References

- BOYCHENKO, K.V., 2017. Mass customization in architecture. *ISJ Theor. Appl. Sci*, 2, pp.49-51.
- CARLYN, M., 1977, An assessment of the Myers-Briggs type indicator. *Journal of personality assessment* 41(5), 461-473.
- CHOMSKY, N., 1957, Towards the Mass Customization of Housing: the grammar of Siza's houses at Malagueira, *Environment and Planning B: Planning and Design*, 32(3), pp. 347-380.
- DAVID M. A., (2004) Mass Customization, the Proactive Management of Variety // *PC AI Magazine*, 2004.
- DEMORAN, A.M., 1997, Differential validity of the Myers-Briggs Type Indicator for Blacks and Whites: An empirical test and comparison of type distributions.
- DUSEK, G.A., YULIYA, V.Y. AND CYNTHIA, P.R., 2015, "Using social media and targeted snowball sampling to survey a hard-to-reach population: A case study. *International Journal of Doctoral Studies* 10(1), 279-299.
- FRUTOS, J. D., AND BORENSTEIN, D. (2003). Object-oriented model for customer-building company interaction in mass customization environment. *J. Constr. Eng. Manag.* 129, 302–313. doi: 10.1061/(ASCE)0733-9364(2003)129:3(302)
- FURNHAM, A., 1996, The big five versus the big four: the relationship between the Myers-Briggs Type Indicator (MBTI) and NEO-PI five factor model of personality. *Personality and Individual Differences* 21(2), 303-307.
- GROBMAN, J. Y., SHEMESH, A., 2015, Space and Human Perception – Exploring Our Reaction to Different Geometries of Spaces, *The Association for Computer-Aided Architectural Design Research in Asia (CAADRIA)*.
- HUNT, R.G., KRZYSTOFIAK, F.J., MEINDL, J.R. and YOUSRY, A.M., 1989. Cognitive style and decision making. *Organizational behavior and human decision processes*, 44(3), pp.436-453.
- IBRAHIM, A.F., ABU-OBEID, N AND AL-SIMADI, F., 2002, The Effect Of Personality Traits On Architectural Aesthetics' Evaluation: Familiar And Non-Familiar Environments As Evaluated By Architectural And Non-Architectural Students, *Architectural Science Review*, 45:3, 197-210, DOI: 10.1080/00038628.2002.9697511.
- KNIGHT, T.W., 2000, Shape Grammars in Education and Practice: History and Prospects, *The Department of Architecture School of Architecture and Planning*, Massachusetts Institute of Technology, Cambridge, MA.
- LUH, W. M., & GUO, J. H., 2001, Using Johnson's transformation and robust estimators with heteroscedastic test statistics: An examination of the effects of non-normality and heterogeneity in the non-orthogonal two-way ANOVA design. *British Journal of Mathematical and Statistical Psychology*, 54(1), 79-94.
- MOLLER, C.B., 1968, *Architectural Environment and Our Mental Health*. New York: Horizon.

A. MAREY, A. BARAKAT

- ONES, H. K. SINANGIL, & C. VISWESVARAN (Eds.), Handbook of industrial, work and organizational psychology, Vol. 1. *Personnel psychology* (p. 233–277). Sage Publications Ltd.
- PINE 11, B.J., 1993, *Mass Customization: The New Frontier in Business Competition*, Harvard Business School Press, Boston.
- PITTENGER, D.J., 1993, The utility of the Myers-Briggs type indicator. *Review of educational research* 63.4 (1993): 467-488.
- POST, E., 1943, Formal reductions of the general combinatorial decision problem, *American Journal of Mathematics*, 65, 197-215.
- SCHOENWITZ, M., NAIM, M., and POTTER, A. (2012). The nature of choice in mass customized house building. *Constr. Manag. Econ.* 30, 203–219. doi: 10.1080/01446193.2012.664277
- STINY, G., 1980, Introduction to shape and shape grammars, *Environment and Planning B* 7(3), 343-351.
- TSENG M.M., JIAO, J. AND MERCHANT M.E., 1996, Design for Mass Customization. *CIRP Annals.* 45(1), 153-156.
- VOZAROVA, T. and SIMKOVIC, V., 2019. Psychological traits as an influence on architectural creation. *World Trans. on Engng. and Technol. Educ*, 17(1), pp.115-120.
- WANG, C. (2018). Mass Customization in Mass Housing : How to design a high-rise apartment through mass customization? Explanatory Document. An unpublished research project submitted in partial fulfillment of the requirements for the degree of Master of Architecture (Professional), *Unitec Institute of Technology*, Auckland, New Zealand.

SHAPEGRAMMAR: A TOOL FOR RESEARCH IN TRADITIONAL ARCHITECTURE

LINAS FATHIMA, CHITHRA K.

National Institute of Technology, Calicut, Kerala

Email address: linasfathima@gmail.com

Email address: chithrak@nitc.ac.in

Abstract. Every Architectural style consists of an Architectural language with vocabulary, syntax, and semantics. The compositional principles of a particular style can be defined over as a set of rules. These rules can be reformed and converted using mathematical computational techniques using Shape Grammar (A systematic method used for interpreting spatial design and activities). Researchers across the world used shape grammar to analyse design patterns of traditional architectural styles, master architects' works, etc. These rule-based methods can be adopted into computer languages to produce new designs. Traditional Architecture of a region portrays culture integrated with all aspects of human life. The proposed paper is to study the potentials of shape grammar to use as a tool in the research of traditional architectural styles by analysing case studies. The research methodology reviews the previous shape grammar studies conducted in various conventional styles and comparative analysis of the approaches of authors in shape grammar generation. The research by Lambe and Dongre on the formulation of shape grammar of Pol houses of Ahmadabad and Cagdas's work on traditional Turkish houses is an example of this. T Knight had formulated shape grammar of Japanese tea houses, and Yousefniapasha and Teeling developed a grammar of vernacular houses facing rice fields of Mazandaran, Iran. Similarly, many researchers used shape grammars as a tool to analyse traditional architecture. So the study will compare the different traditional shape grammar generations and formulate a sample shape grammar of a traditional prototype to conclude the scope of further research in the domain.

Keywords: *Shape grammar, traditional architecture, Architectural language*

ملخص. يشتمل كل اسلوب معماري على لغة معمارية تحتوي على مفردات ونحو ودلالات. يمكن تعريف المبادئ التركيبية لاسلوب معين بانها مجموعة من القواعد. يمكن اصلاح هذه القواعد وتحويلها باستخدام تقنيات حسابية رياضية باستخدام قواعد الشكل (طريقة منهجية تستخدم لتفسير التصميم و الانشطة المكانية). استخدم الباحثون في جميع أنحاء العالم قواعد الاشكال لتحليل انماط تصميم الاساليب المعمارية التقليدية واعمال المهندسين المعماريين الرئيسيين وما إلى ذلك. يمكن اعتماد هذه الاساليب القائمة على القواعد في لغات الكمبيوتر لإنتاج تصميمات جديدة. تصور العمارة التقليدية لاي منطقة ثقافتها المناسبة بجميع جوانب الحياة البشرية. تهدف الورقة المقترحة إلى دراسة إمكانات قواعد الشكل لاستخدامها كاداة في البحث عن الاساليب المعمارية التقليدية من خلال دراسات الحالات. يستعرض منهج البحث دراسات قواعد الشكل السابقة التي اجريت في مختلف الاساليب التقليدية والتحليل المقارن بنظرات المؤلفين في تكوين قواعد الشكل. يعد البحث الذي اجراه لامبي ودونغري حول صياغة القواعد الشكلية لمنازل بول في احمد آباد وعمل كاجداس على المنازل التركيبية التقليدية مثالاً على ذلك. قام تي نيت بصياغة قواعد نحوية لببوت الشاي اليابانية وطور يوسف نيا باشا و تيلنج قواعد نحوية للمنازل المحلية المواجهة لحقول الارز في مازندران بيران. وكذلك استخدم العديد من الباحثين القواعد النحوية الشكلية كاداة لتحليل العمارة التقليدية. ومن اجل ذلك ستقارن الدراسة بين الاجيال النحوية للشكال التقليدية المختلفة وتصوغ نموذج قاعدة نحوية تقليدية لاستكمال نطاق البحث الاضافي في المجال

الكلمات المفتاحية: الشكل النحوي والعمارة التقليدية واللغة المعمارية.

1. Introduction

Traditional Architecture of a region has evolved by witnessing the evolution of culture, geography, and other regional characteristics. Conserving traditional architectural styles is the best method to conserve the heritage value of a place. Traditional Architectural styles have compositional rules and principles that were evolved by the trial and error method corresponding to the culture, geography, and other regional characteristics. Hence, to define a particular traditional style, it is essential to learn and understand the language of the corresponding architectural style. Shape grammar is used as a tool to decode the language of architectural styles by many researchers. It is an efficient tool which helps to understand the spatial relationships in architecture. Generation of shape grammar helps in the analysis of existing architectural styles and the generation of new forms. This study analyses the competencies of shape grammar as a tool to understand traditional architecture by reviewing the approaches used in previous research on different architectural styles. The case studies are selected such that the method of shape grammar generation is different in the selected research. Also, a sample shape grammar is generated on a traditional prototype.

2. Shape grammar: A logical argumentation method

Shape grammar is a systematic method used under mathematical-formal logical systems in logical argumentation of architectural research (Linda Groat, 2002). Architectural language consists of vocabulary, syntax, and

SHAPEGRAMMAR: A TOOL FOR RESEARCH IN TRADITIONAL ARCHITECTURE

rules similar to natural languages. Shape grammar plays an essential role in defining the design rules in architectural language. A shape grammar is a set of rules that are applied in the step by step to generate architectural language or design., hence it plays an essential role in defining an architectural design(T. W. Knight, 1999). In 1972, James Gips and George Stiny introduced shape grammars in their research titled "Shape Grammars and the Generative Specification of Painting and Sculpture'. They had identified shape and shape grammar as a specification which is generative and visual (Stiny and Gips,1995). The shape rules are the descriptions in the shape grammar generation process. The fundamental component of shape rules are shapes, points lines or planes. (T. Knight, 1999) For example, Figure 1 shows the simplest two-step shape grammar generation. The first rule takes a square and moves along its diagonal direction.

Similarly, in the second rule, an L shape moves along the diagonal path. A datum point is fixed and shows before and after movement. The rules can be Shape operations such as addition, subtraction, and other transformations or movements with specific orientations. The computation starts with a double L shape. There are other possibilities of formation also, but in each stage, the user can decide what shapes to see and what action to do next(Knight, 2015). Last forty years. Researchers and designers had used shape grammar as a generative tool in various fields. They evolved many applications out of shape grammar theory such as colour grammars, structure grammars etc.

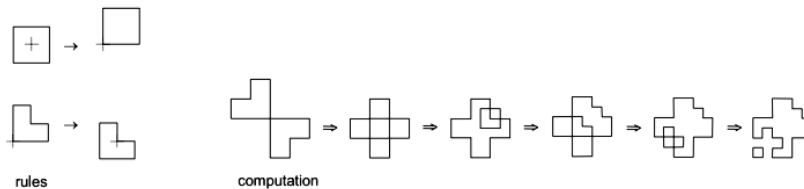

Figure 1. Shape grammar and computation rules example

2.1. SHAPE GRAMMARS AND IT'S APPLICATIONS

The early researchers have used shape grammar as a technique to analyse design patterns in the works of master architects. Duarte analysed design patterns of Alvar Siza's patio houses at Malagueira using shape grammars(Duarte, 2005). Paio, along with five other authors, generated a shape grammar based computational tool for developing a sustainable and integrated urban design(Paio *et al.*, 2011). Eilouti had used shape grammar as a reverse engineering method for the generation of architectural façade design(Eilouti, 2019). Cromwell, Lu and Steinhardt used shape grammar rules to derive Islamic ornamental patterns (Cromwell, 2009)(Lu and Steinhardt, 2007). Li's article uses shape grammar as a tool to teach Yingzao

Fashi's architectural style (Li, 2001). Maria Angela Dias had generated shape grammar of an informal city, Rocinha Favela in Brazil (Dias, 2014). The authors' expectation was that study would help improve housing and public space in the favela. Eloy and Duarte had used shape grammar to analyse the quality of designs with a comparative test on Lisbon apartments (Eloy and Duarte, 2014). Yue and Krishnamurti had estimated Queen Anne houses' interior layout using shape grammar to capture the building style (Yue, Krishnamurti and Grobler, 2012). Various researchers had used shape grammar to analyse the different traditional architecture

3. Shape grammar as a tool in traditional Architecture

Cagdas had derived shape grammar to derive the language of Turkey's traditional houses (Çağdaş, 1996). Lambe and Dogre formulated shape grammar of the Pol houses of Ahmedabad to generate contextual designs (Lambe and Dongre, 2019). T Knight had developed shape grammar of traditional Japanese houses in forty-two steps considering ceremonial aspects of Japanese tea ceremony (Knight, 1981). Majid and John studied forty-four houses in four villages to identify compositional rules of vernacular houses facing rice fields (Yousefniapasha *et al.*, 2019). Chiou and Krishnamurti's application of shape grammars on Taiwanese traditional vernacular dwellings is one of the most-cited publications in the domain (Chiou and Krishnamurti, 1995a). Herbert and Sander's research generates shape grammar of African Ndebele homesteads that obey all social customs and structural properties of traditional settlement and avoid external influences (Herbert, Sanders and Mills, 1994). Two cases from traditional architecture with different approaches selected as case studies for this research.

3.1 CASE STUDY 1-TRADITIONAL TURKISH HOUSES

The traditional Turkish houses are single-storied houses built between the 15th and 16th centuries in the Ottoman Empire. The ground floor is used for ancillary purposes when the house has more than one floor. The house contains spaces such as bedrooms, stairs, laundry, pantry, kitchen, hall etc. Cagdas had formulated the parametric shape grammar of these houses as they were getting demolished widely (Çağdaş, 1996). Turkish houses' peculiarity is that they have several plan types based on plan shape, location of central hall etc. Cagdas had identified plan elements and types of plan in the first stage. The method Cagdas used in generating grammar of Turkish houses is similar to the method used by Flemming for Queen Anne houses (Flemming, 1987). The generation process employed by Cagdan starts by locating a particular space and proceeds by adding the adjacent areas to the

SHAPEGRAMMAR: A TOOL FOR RESEARCH IN TRADITIONAL ARCHITECTURE

plan composition (similar to the grammar derived by Lambe and Dongre in pol houses) (Çağdaş, 1996). Here an imaginary grid guides the placement of elements (similar to the tea house grammar by T Knight). Hence can define Cagdas's approach as a combination of both these approaches. A grid-based representation system can combine graphical and abstract depictions of vocabulary elements, and thus it treats lines symbolically rather than mathematically according to the coordinate system. (Çağdaş, 1996). the initial shape of grammar generation labelled as point K on the coordinate system. The polygonal shape hall's left corner is coinciding with K in the initial step. The author created other vocabulary elements from the transformation of the main vocabulary elements. A computer can easily convert the data into descriptions as a grid is guiding the process. Cagdas represented each polygon as a 3x3 matrix and sub shapes represented by larger matrices (Figure 2) matching their configurations.

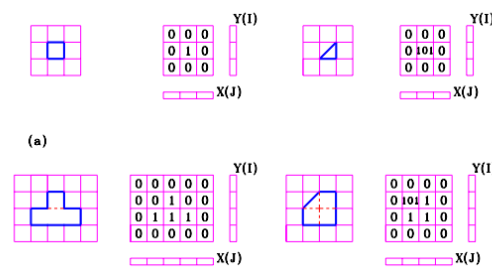

Figure 2. Shapes as represented as matrices (Çağdaş, 1996)

Cagdas represented shapes with integer numbers '1' and '0' for empty cells in the matrix. The same integer numbers represent the sub shape in a block as in a matrix. The usage of a matrix to represent polygon is necessary to convert the symbolic representations into graphical outputs for the algorithm generation. Even spatial relations illustrated using integers in the matrix. These spatial relations are necessary for grammar generation.

3.1.1. Grammar Generation

The author had generated grammar by grouping the rule sets into two. They are plan types belonging to the outer hall (ROn) and inner hall separately (RIn), and he generated grammar for both the groups. But the initial shape for grammar generation was the hall in both groups. Cagdas generates the grammar of Traditional Turkish Houses using eight rule sets. The first six rule sets create the plan layouts, and the last two rule sets refine the plan layouts. Each rule sets defines all the possible spatial adjacencies of space. The final rule set represents shape rule schemata that determine the inflected corners. Figure 3 shows a tree plan layouts generated by Cagdas for Turkish Houses with an outer hall. Cagdas mentions that the method can't be used to

L. FATHIMA, C. K.

create palaces and Konark plans by combining more plan types.

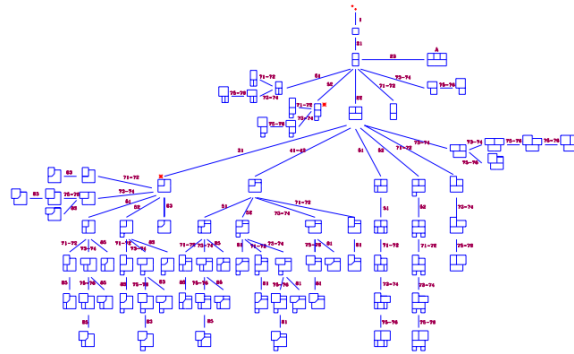

Figure 3. Part of a tree diagram of plan layout generated for houses with a central hall.(Çağdaş, 1996)

3.2. CASE STUDY 2- TAIWANESE TRADITIONAL HOUSES

Taiwanese architecture is a branch of Chinese architecture with slight unique characteristics—styles in Chinese architecture characterised by people, type of building, and construction type. Even though Taiwan is a typical migrant society, each migrant group has an architectural style related to that of their native place (Chiou and Krishnamurti, 1995). Site is the most important factor in traditional Taiwanese design. The repetition of massing elements produced site plans. In conventional Taiwanese buildings, nearly all were bilaterally symmetric about to central line through the main hall. The main hall is considered sacred among family spaces. All the significant spaces lie on this axis, and secondary spaces lie on the left or right of this axis. Taiwanese traditional buildings have primary and secondary buildings. The main buildings were transverse to the axis of symmetry, and the secondary building was parallel. The axis of symmetry is bisecting the central room and all the other spaces generated through this hall.

3.2.1. The grammar

The Chiou and Krishnamurthi had developed shape grammar of Taiwanese houses in seventeen stages. The first stage is establishing the fortunate numbers. The initial point for grammar generation is key brick, and it is represented as *(asterisk). The stage one consists of two rules. Rule 1 determines the orientation by defining the axis of symmetry. Fortunate dimensions of the building are computed using the next rule. Principles of feng-shui and orientation are the basis of fortunate dimensions. The rule schema selects one set of fortunate numbers from many.

SHAPEGRAMMAR: A TOOL FOR RESEARCH IN TRADITIONAL ARCHITECTURE

The authors generated the central room of the principal building *d* in stage 2. The central hall is situated on the central axis with key brick as its centre. The central room is generated using four rules. Stage three adds openings to the central room. Taiwanese houses consist of two types of doors, main doors and regular doors. There are ten rules in this stage which can be classified into three. Rules 7 to 9 creates openings in the front wall of the central hall. The second group creates openings on the rear wall, and the last rule creates openings in both walls. There are four rules at this stage. Stage four generates the plan of the main building using seven sets of rules. First, two rules create the plan of the main building. The next rule adds two rooms to the main building. Rule 18 terminates the generation of the principal building. Rule 19 adds an additional space within the room by adding a wall. Rule 20 and 21 extend porch across the already added rooms. Stage 5 adds openings to the rooms in the main building. All the rooms in the main building are directly or indirectly connected to the central room. Rooms were with a minimum number of openings. The fifth stage consists of two sets of shape rules. The first group consists of rules for adding placeholders for doors and other groups for windows. And stage 6 replaces doors and windows by their two-dimensional icons. The seventh stage generates a courtyard at the front of the main building. Courtyards in the Taiwanese houses are open space between the main building and two secondary buildings. The plan of the secondary building is generated in stage 8. The secondary building connects the main buildings parallel to the line of symmetry. 9th stage computes the fortunate dimensions of the main building, which is in front of a courtyard. The procedure here is similar to stage 1, but building height also is considered here. Height of the building should be less than the main building. Stage 10 generates the main building plan, which is in front of a courtyard. The next stage generates a secondary building which surrounds the front main building. The secondary building's extent is given by the sum of depths of front buildings and the courtyards. 12th stage generates another kind of secondary building connected by a passing room to the end room of the main building (Chiou and Krishnamurti, 1995). These secondary buildings are perpendicular to the line of symmetry. In stage 13, openings are added to secondary structures. Stage 14 describes the rules for making platforms, an essential component of Chinese architecture. Roofs represent a person's social position in Chinese architecture—stage 15 represents the rule schema for creating roofs. 16th stage modifies the lines in the plan to three-dimensional walls. The height of the wall depends on the roof. The last stage is termination, in which all the labels used in plan generation are erased. The stage has four rules Chiou and Krishnamurti had formulated the grammar of traditional Taiwanese houses with bilateral symmetry as an essential feature (Chiou and Krishnamurti, 1995).

4. A Sample Grammar Generation of a traditional prototype

A sample shape grammar generation was conducted on a traditional prototype to verify different grammar generation methods. A traditional prototype with informal development was selected for grammar generation. Kuttichira is a Muslim settlement in Calicut district of Kerala, India. The user communities of the settlement were tradesman. They followed the matrilineal inheritance system to ensure women's safety in their apartments as men were away with trade. They constructed huge mansions to incorporate their large joint families. These mansions were introverted in planning and with strict segregation of male and female areas. Five samples were selected from the settlement and documented. The selected houses were older, about 100-150 years. The vocabulary and grammar of the prototype were derived from the plan based on a detailed analysis.

4.1 VOCABULARY OF KUTTICHIRA MUSLIM MANSIONS

The Kuttichira houses are two-storied structures with the introverted planning system. One of the main planning criteria is the privacy of ladies areas due to Islamic principles. This results in a clear division of spaces into the male area, female area and common area. Even though all the mansions' basic layout in the settlement is similar, the scale and detailing differ concerning the user's financial attributes. The main elements of the plan (Main door, Main windows, and Main spaces) are aligned on the central axis.

Males of the family use the frontal areas of the mansion, including *Kolaya*(Verandah), *Padappuram* and a central hall. *Padappuram* is an inner verandah mainly utilised during functions for the family. *Padappuram* consists of two platforms (135cm height) on either side of the central axis. The bedroom of the senior-most male member is situated on either side of *Kolaya*. *Naduvakam* is a central room used by females of the family. Space consists of a small courtyard meant for lighting and ventilation. The bedrooms of females are situated next to *naduvakam*. According to their customs, every woman is provided with an *ara* during the wedding. *Ara* is a self-contained room which includes all facilities for dining, sleeping and relaxing etc. The first floor of these mansions is entirely meant for newly wedded couples. These houses contain big kitchens to feed the entire family. Above mentioned are the main elements of a typical Kuttichira Muslim mansion. Figure 4 shows the plan of a typical layout of Kuttichira Mansion.

SHAPEGRAMMAR: A TOOL FOR RESEARCH IN TRADITIONAL ARCHITECTURE

4.2 THE GRAMMAR GENERATION

The Samples were analysed for understanding the variations in design typologies. The grammar generation is carried out in twelve stages; in which each stage contains several rules.



Figure 4. Plan of a typical Kuttichira Mansion (Fathima, 2018)

The grammar generation method is a combination of Pol houses' grammar and vernacular houses of Mazandaran (Lambe and Dongre, 2019)(Yousefniapasha *et al.*, 2019). The grammar derivation begins with generating midpoint of the site and generating axis through the centre in NW and SE direction. The kitchen is considered as a unit for simplifying grammar generation. Toilets were not considered in grammar generation as they were later additions. A system of labeling is used in grammar generation. Each space is denoted as *s* (an abbreviation of space). For example, *kolaya* is denoted as *s(k)*. Interior walls and perimeter walls are denoted as *I(w)* and *P(w)*. Door, main door and window are represented as 'D', 'MD' and 'W' respectively. 'I' denotes *irunila* and 'v' denotes verandah. The first stage generates the central axis. *Padappuram* is considered an important datum point in grammar generation. In the second stage, *Padappuram* is placed in the central axis using two rules. In the third stage, *Kolaya* is placed in two rules (Rules 4-5). In the fourth stage, the gent's common room is placed using two rules. The bedroom of *karanavar* is placed in the fifth stage using a single rule. The placement of *naduvakam* is described in the sixth stage using four rules (Rules 11-14). The rule for placing ladies rooms around *naduvakam* is described in the seventh stage using two rules. The eighth stage describes the rules for generating stair (Rules 17-18). The kitchen is generated using the rule sets in stage 9. The verandah is added in the tenth stage using four rules (Rules 21-25). The eleventh stage describes the placement of doors, windows, main doors using different rule sets (Rules 26-48). The last stage describes the placement of

columns using three rules. The grammar of Kuttichira houses consists of several derivations under two main types. That is mansions without a common central hall and mansions with a central hall. Figures 5, figure 6, figure 7, serially shows the grammar generation.

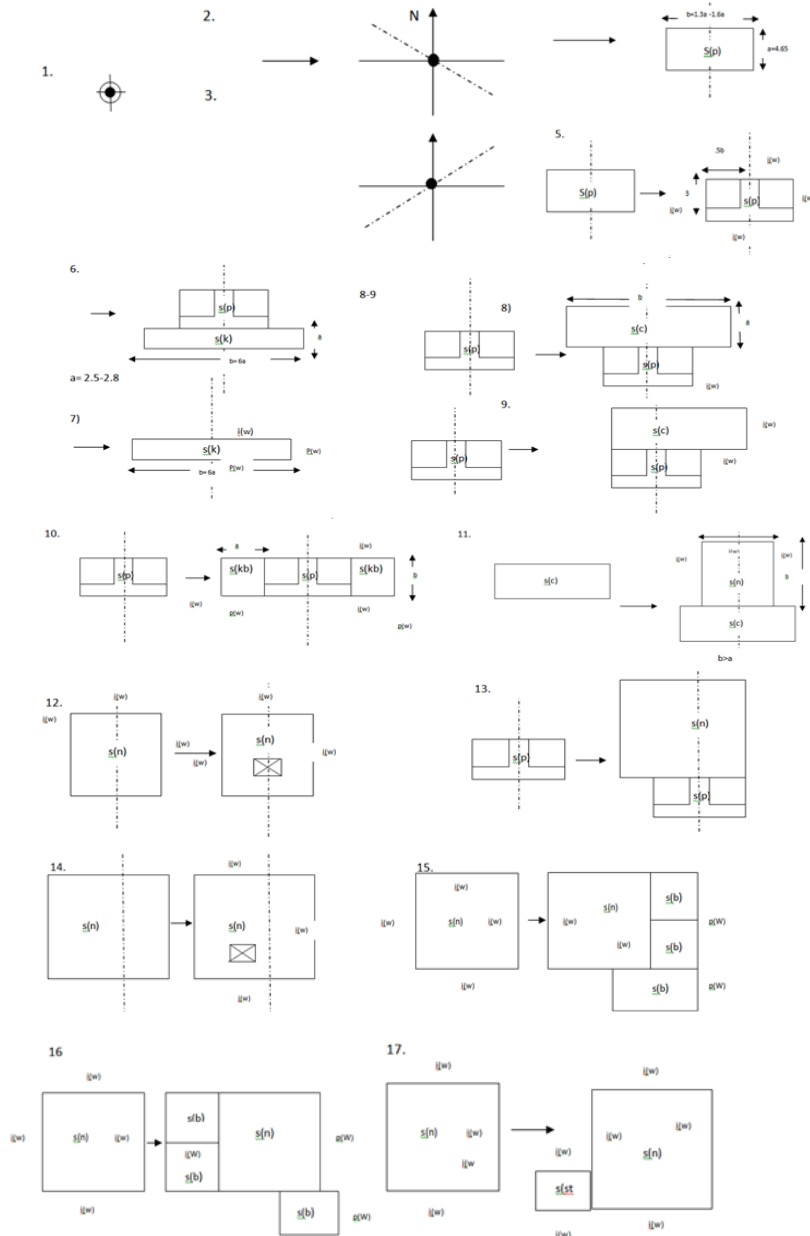

Figure 5. Sample grammar generation

SHAPEGRAMMAR: A TOOL FOR RESEARCH IN TRADITIONAL ARCHITECTURE

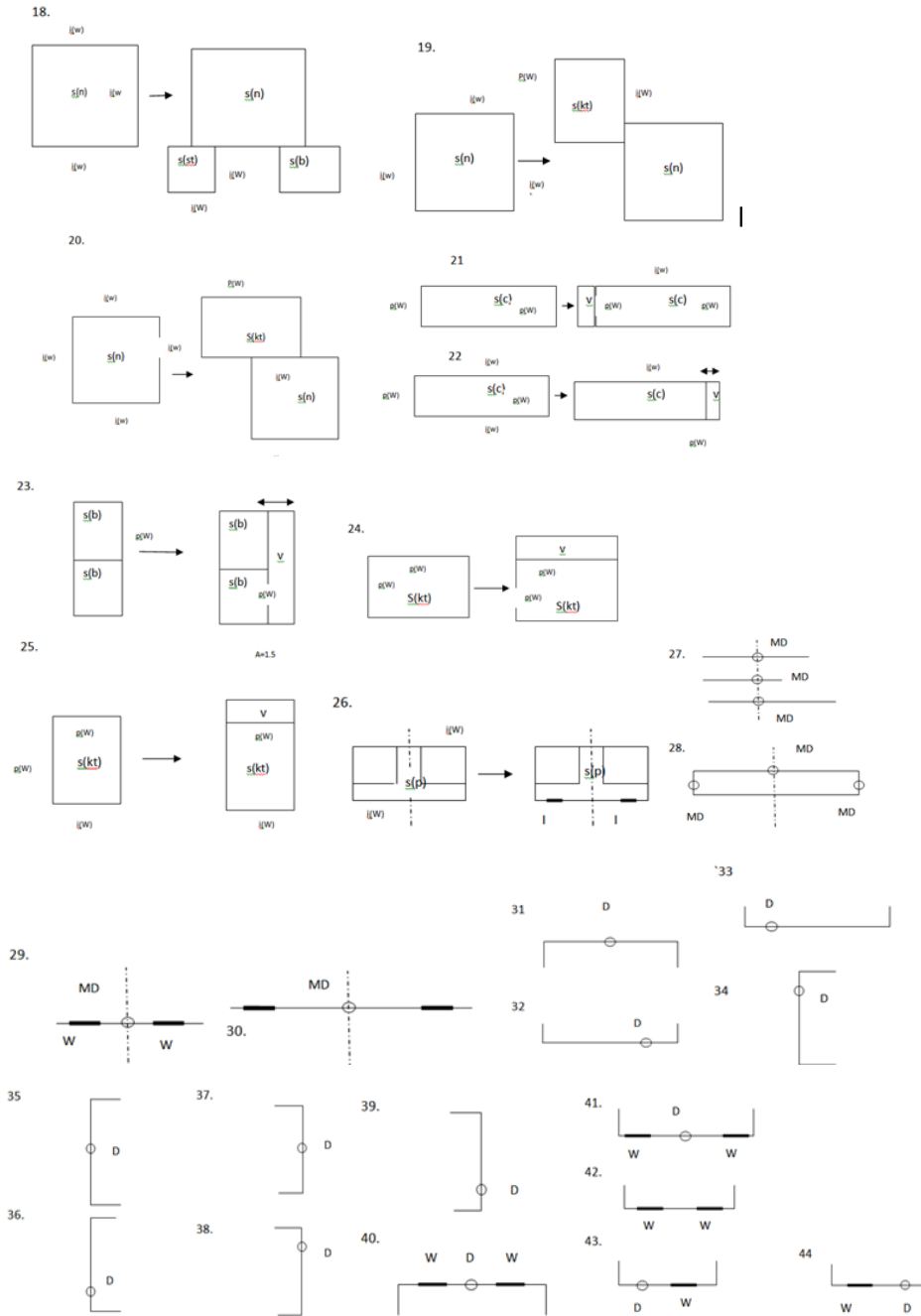

Figure 6. Sample grammar generation

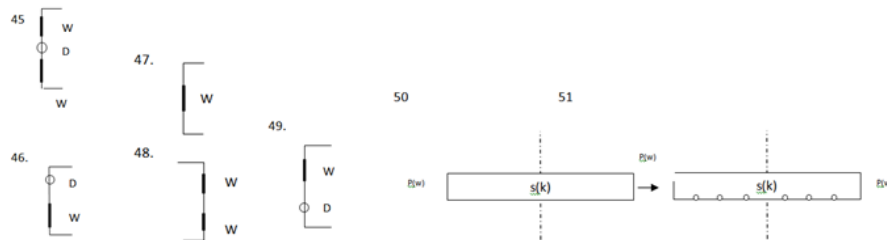

Figure 7. Sample grammar generation

4. Discussion

The two case studies depict two different ways of grammar generation in traditional architecture. In the case of shape grammar of Turkish houses, an imaginary grid line guides the generation process, and several derivations are possible in this. The parametric shape grammar has a generative approach as substitution rule sets represent the spatial relations in the plan layouts. The polygon representing the hall is considered the initial shape of the grammar as the hall type determines the plan type of Turkish house. Shapes are mathematically represented using integer matrices in this approach. Here, shape grammar is generated in two-dimensional layouts only. The usage of grid prevents spatial uncertainty and control interpenetration of blocks and spaces. Cultural and climatological factors regarding the traditional style are not studied in this approach. In the second case study of Taiwanese houses, the derivation starts by locating the central axis, and the bilateral symmetry of the plan has great importance in the derivation. Another difference, in this case, is that the house is not a single building. Chiou and Krishnamurti defined the generation of primary and secondary buildings based on the relation to the main building and symmetry. The generation process is about the hierarchy of buildings. The method is suitable for styles in which building complex consists of several buildings and follows symmetry.

The sample grammar generation is conducted in a third method similar to Lambe and Dongre's Pol house grammar (Lambe and Dongre, 2019) and Yousefniapasha's Mazandaran vernacular house grammar (Yousefniapasha *et al.*, 2019). In which, A base point is located based on the climatological and cultural factors. And generation begins with locating axis on the basepoint. A datum space is located on the axis, and other spaces are generated based on the hierarchy and proximity of spaces with respect to that. The generated grammar is non-deterministic grammar with multiple derivations. The grammar generation consists of 12 stages and 57 rules. Figure 8 shows the possible shape computations. In the designs that have informal development of spaces and have a hierarchy in their importance, the method used in

SHAPEGRAMMAR: A TOOL FOR RESEARCH IN TRADITIONAL ARCHITECTURE

Kuttichira houses can be applied. The three cases depict three different approaches to shape grammar generation of traditional prototypes. Even from a primary observation, we can analyse that the plan character has an important role in determining the derivation methodology.

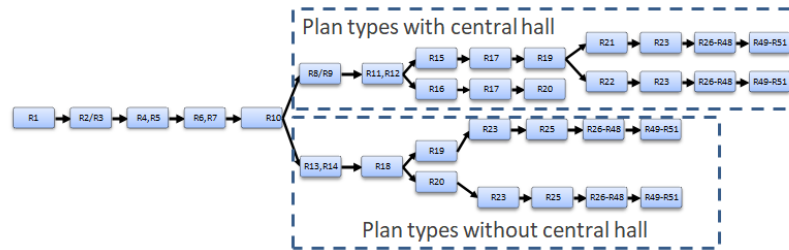

Figure 8. Shape Computation

4. Conclusion

Traditional architecture styles have specific compositional principles and homogeneity within it. Hence it is essential to define the language of traditional architectural styles to comprehend it better. Shape grammar is an efficient tool to appreciate traditional architectural styles. It will also help in the generation of architectural designs following traditional design principles. As the traditional architecture of a region is evolved respecting the region's climate and culture, it will be useful to consider the cultural and climatical rules also in the rule schemata like in the grammar generation of Kuttichira house. The researchers can choose the methodology of shape grammar generation based on the type of plan and form of structure. In the designs that have informal development or spaces and have a hierarchy in their importance, the method used in Kuttichira houses can be applied. In the case of non-deterministic grammars, usage of imaginary grids will reduce ambiguity in the generation process, as evident in the grammar generation of Turkish houses. The structures which have bilateral symmetry can adapt the approach used in the case of Taiwanese houses. The same method can use for the cases with multiple blocks also. The selection of grammar generation method can be based on the plan configuration of buildings. Hence the shape grammar can be used as an efficient tool that can generate or decipher the language of various architectural styles.

References

- Çağdaş, G. (1996) 'A shape grammar: The language of traditional Turkish houses', *Environment and Planning B: Planning and Design*, 23(4), pp. 443–464.
- Chiou, S. C. and Krishnamurti, R. (1995a) 'The fortunate dimensions of Taiwanese traditional architecture', *Environment & Planning B: Planning & Design*, pp. 547–562.
- Chiou, S. C. and Krishnamurti, R. (1995b) 'the grammar of taiwanese traditional vernacular dwellings', *Environment & Planning B: Planning & Design*. Environment and Planning B: Planning and design, 22, pp. 689–720.
- Cromwell, P. R. (2009) 'The search for quasi-periodicity in islamic 5-fold ornament', *Mathematical Intelligencer*, 31(1), pp. 36–56. doi: 10.1007/s00283-008-9018-6.
- Dias, M. Â. (2014) 'Informal Settlements - A Shape Grammar Approach', *Journal of Civil Engineering and Architecture*, 8(11), pp. 1389–1395.
- Duarte, J. P. (2005) 'Towards the mass customization of housing: The grammar Siza's houses at Malagueira', *Environment and Planning B: Planning and Design*, 32(3), pp. 347–380.
- Eilouti, B. (2019) 'Shape grammars as a reverse engineering method for the morphogenesis of architectural façade design', *Frontiers of Architectural Research*. Elsevier Ltd, 8(2),.
- Eloy, S. and Duarte, J. P. (2014) 'Inferring a shape grammar: Translating designer's knowledge', *Artificial Intelligence for Engineering Design, Analysis and Manufacturing: AIEDAM*, 28(2), pp. 153–168. doi: 10.1017/S0890060414000067.
- Fathima, L. (no date) 'Shape grammar as a tool for research in traditional architecture'.
- Flemming, U. (1987) 'More than the sum of parts: the grammar of Queen Anne houses', *Environment and Planning B: Planning and Design*, 14(3), pp. 323–350.
- Herbert, T., Sanders, I. and Mills, G. (1994) 'African shape grammar: a language of linear Ndebele homesteads', *Environment & Planning B: Planning & Design*, 21(4), pp. 453–476.
- Knight, T. (1999) 'Shape grammars in education and practice: History and prospects', *International Journal of Design Computing*, 2, p. 82152.
- Knight, T. (2015) 'Shapes and Other Things', *Nexus Network Journal*. Springer Basel, 17(3), pp. 963–980. doi: 10.1007/s00004-015-0267-3.
- Knight, T. W. (1981) 'The forty-one steps', *Environment and Planning B, 1981, volume 8, pages 97-114*, 8, pp. 97–114. doi: 10.1068/b080097.
- Knight, T. W. (1999) 'Shape grammars: Six types', *Environment and Planning B: Planning and Design*, 26(1), pp. 15–31. doi: 10.1068/b260015.
- Lambe, N. R. and Dongre, A. R. (2019) 'A shape grammar approach to contextual design: A case study of the Pol houses of Ahmedabad, India', *Environment and Planning B: Urban Analytics and City Science*, 46(5), pp. 845–861. doi: 10.1177/2399808317734207.
- Li, A. I. (2001) 'A shape grammar for teaching the architectural style of the Yingzao fashi Volume 1, Text', *Text*, 1(March), p. 51.
- Linda Groat, D. W. (2002) 'Architectural Research Methods', Wiley.
- Lu, P. J. and Steinhardt, P. J. (2007) 'Decagonal and quasi-crystalline tilings in medieval Islamic architecture', *Science*, 315(5815), pp. 1106–1110. doi: 10.1126/science.1135491.
- Paio, A. et al. (2011) 'Emerg.cities4all. Towards a shape grammar based computational system tool for generating a sustainable and integrated urban design', *RESPECTING FRAGILE PLACES [29th eCAADe Conference Proceedings]*, (October 2016), pp. 152–158.
- Yousefniapasha, M. et al. (2019) 'Shape grammar, culture, and generation of vernacular houses (a practice on the villages adjacent to rice fields of Mazandaran, in the north of Iran)', *Environment and Planning B: Urban Analytics and City Science*, 0(0), pp. 1–21.
- Yue, K., Krishnamurti, R. and Grobler, F. (2012) 'Estimating the interior layout of buildings using a shape grammar to capture building style', *Journal of Computing in Civil Engineering*, 26(1), pp. 113–130. doi: 10.1061/(ASCE)CP.1943-5487.0000129.

SURFACE SHAPE GRAMMAR MORPHOLOGY TO OPTIMIZE DAYLIGHTING IN MIXED-USE BUILDING SKIN

SAMMAR Z. ALLAM, SOHA EL GOHARY
October University for Modern Sciences and Arts
Email address: samar.allam@gmail.com
Faculty of Engineering, Cairo university
Email address: arch.sohaelgohary@hotmail.com

AND

MAHA EL GOHARY
Faculty of Engineering, Cairo University
Email address: eng.m-elgohary@hotmail.com

Abstract. Building Performance simulation is escalating towards design optimization worldwide utilizing computational and advanced tools. Egypt has its plan and agenda to adopt new technologies to mitigate energy consumption through various sectors. Energy consumption includes electricity, crude oil, it encompasses renewable and non-renewable energy consumption. Egypt Electricity (EE) consumption by sector percentages is residential (47%), industrial (25%) and commercial (12%), with the remainder used by government, agriculture, public lighting and public utilities (4%). Electricity building consumption has many divisions includes HVAC systems, lighting, Computers and Electronics and others. Lighting share of electricity consumption can vary from 11 to 15 percent in mixed buildings as in our case study which definitely less than the amount used for HVAC loads. This research aims at utilizing shape morphogenesis on facades using geometric shape grammar to enhance daylighting while blocking longwave radiations causing heat stress. Mixed-use building operates in daytime more than night which emphasizes the objective of this study. Results evaluation is referenced to LEED v4.1 and ASHRAE 90.1-2016 window-to-wall ratio calibration and massive wall description. Geometric morphogenesis relies on three main parameters; Pattern (Geometry Shape Grammar: R1, R2, and R3), a reference surface to map from, and a target surface to map to which is the south-western façade of the case study. Enhancing Geo-morph rule is to guarantee flexibility due to the rotation of sun path annually with different

azimuth and altitude angles and follow LEED V4.1 enhancements of opaque wall percent for building envelope.

ملخص. تحسين أداء المباني باستخدام برامج المحاكاة في تقدم مستمر باستخدام التقنيات الحديثة ووسائل التصميم المتنوعة باستخدام الحاسب. وضعت مصر خطة لتطويع التكنولوجيا الحديثة في إطار خفض استهلاك الطاقة في مجالات عدة. فنسب الاستهلاك الكهربائي في قطاعات شتى مثل الإسكان 47%، والصناعة 25%، والتجارة 12%. أما سائر القطاعات كالحكومة والزراعة والإضاءة العامة والخدمات تصل الي 4%. تنقسم استهلاك الكهرباء للمباني في أجهزة التكييف، أجهزة الحاسبات والالكترونيات وغيرها. يتراوح استهلاك المباني لكهرباء للإضاءة فقط من 11 الي 15 كنسبة مئوية كما تزيد عن هذه النسبة استهلاك أجهزة التكييف. لذلك تتناول هذه الدراسة الاشكال المحورة والمتغيرة الهندسية للاستمتاع بإضاءة طبيعية مع الحد من انبعاثات الشمسية ذات الموجات الطويلة التي تزيد من احمال أجهزة التكييف. تم اتباع نظرية التعامل مي تغيير وتشكيل وتحويل الاشكال الهندسية في الواجهات. تتناول الدراسة تطبيق على احدى المشاريع ذات الاستخدامات المتنوعة بمصر. بالإضافة الي اتباع نظم التوصيف لحوائط الواجهات مع نظم من نظم تصنيف المباني الخضراء لاتباع النسب المقبولة للزجاج من الواجهات. في نطاق العمل على الاشكال الهندسية للواجهات تم اتباع 3 قوانين تحت نطاق تطبيق نظرية الاشكال. كما تم تحويل هذه الاشكال تبعاً لمسار الشمس سنويا في 21 مارس، 21 يونيو، 21 سبتمبر و21 ديسمبر. أخيراً تم تقييم النتائج بالرجوع الي معايير تصنيف المباني الخضراء والمستدامة.

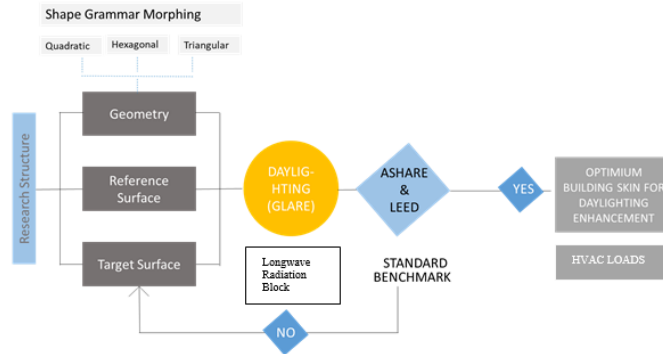

Figure 1. Research Structure

1. Introduction

Office building contributes generously to total energy consumption. Egypt sets a plan to re-orient its energy consumption plan to include energy-efficient uses. Electricity is consumed by different end users in the economy divided between residential (47%), industrial (25%) and commercial (12%), with the remainder used by government, agriculture, public lighting and public utilities (4%), as shown in Figure 2.

SURFACE SHAPE GRAMMAR MORPHOLOGY TO OPTIMIZE DAYLIGHTING IN MIXED-USE BUILDING SKIN

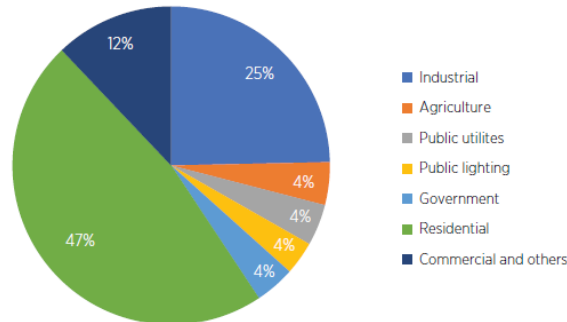

Figure 2. . Electricity consumption by Sector, (IRENA, 2015)

These statistics trigger in-depth studies to address energy and electricity consumption plan to refine consumption and tailor design to mitigate HVAC loads and rely more on daylighting. South facades in hot arid zones have always gained designers attention to induce innovative ideas to minimize solar radiation transmission and at the same time benefit natural daylighting. Louvres are one of the designers' solutions to deal with south façade. During warm summer months, buildings must maintain an adequate and comfortable temperature for the users of the space. Blinds or solar screens are an effective solution in projects that have large glazed surfaces, thus reducing the temperatures generated by direct sunlight. (Franco, 2018)

Nevertheless, the correct use of glass in office buildings plays a key role in the efficient use of energy (Ahmed R. abdeen, 2017) Reducing glazing surface area in south facades reduces glasshouse effects high tras solar radiations insie interior spaces which increase indoor thermal heat.

Based on the above assumptions, this research invesitagtes the different percentage of solids to voids (opening glazing) to follow sunpath and limit solar radiation transmitted to indoor spaces.

1.1 SHAPE GRAMMER MORPHING

Exploring different geometries and experimenting each shape potentials is to meet architectural design doctrines; Form, Function and structure. Selecting quadratic, hexagon and trangular as they are manifesting biomorphic forms, structural triangulation of trusses while at the same time perform funcionally in opening and closing during daily use. This research conveys shape grammar algebra on these geometries through a geo-morph.

1.1.1 Shape Grammar

Shape grammars are rule-based formalisms for the specification of shape languages(Tiemen Strobbe, 2016). Using various shapes as a vocabulary to

demonstrate innovative designs is to leverage design outputs with shape typologies.

Shape grammars are systems of visual rules by which one shape may be transformed into another. (Stiny, 2018) shape transformation, deformation or morphology are rule-based changes. Morphology is an adequate shape language to describe changes in shapes (hexagonal, triangular, Quadratic) to apply to sunpath at selected time intervals.

Shape rules includes several operations including scale, reflection, translation, rotation as shown in figure 3. Computing shape rules and blending designed operations can generate infinite algorithmic transformations.

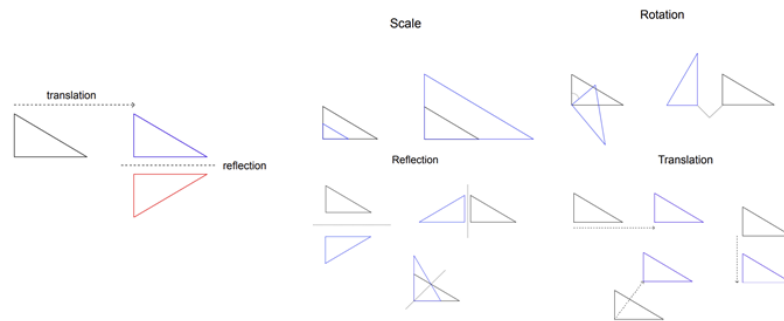

Figure 3. Shape algebra – combination of many operations for shape transformation

The field of shape grammars spans 47 years, but its potential in the practice and education of art, architecture, and engineering remains far from being utilized. (Eilouti, 2019). However, many researched has explored the ruled of the language of shape grammar on multiple architectural applications. In 2019, Eilouti has applied morphological analysis on a contemporary style case study that exhibits non-orthogonal configurations.

Shape algorithm has been applied and induced in the design of a gothic spire (Roriczer). Shape algebra is based on the divisions of its sides and drawing a new square at mid points. Recursive algebra to deduce new shapes is based on the original one.

Shape grammars allows intervention at multiple steps which helps in bringing subjectivity in the design process and helps in achieving a design which is truly unique and not a standardized module. (Anant prakash, 2017) Generating creative geometries in architecture design based on shape rules has been always been the aim of manipulating shape rules without interpreting environmental parameters.

Shape grammars is the domain of visual study that deals with the morphological language, numerical relations, and topological structures of design products and the incremental and recursive processes that generate them (Eilouti, 2012) (Eilouti, 2017). Hence, this study is concerned with

SURFACE SHAPE GRAMMAR MORPHOLOGY TO OPTIMIZE DAYLIGHTING IN MIXED-USE BUILDING SKIN

morphological topologies on geometries based on numerical relation referenced to solar-position readings and force-field algorithm.

1.1.2 Morphing Rule

Inducing microclimatic parameters like solar radiations or tracing daylight rays to control these rules shall add a sophisticated value behind shape algebraic transformation.

Morphology is a terminology related to the form and structure of something or a branch of biological science that deals with the form and structure of animal and plants. (Definition of morphology, n.d.). Genetic transformation as it is based on structural rules which inherit from an original organism finding new species.

This research adopts a morphology rule to follow computational thinking design in generating morphological shapes based on solar radiation as an attractor rule that manipulates shape grammar outputs. The privileging of performance within the design process is described as an interest in “morphogenesis.” (D.Stavridou, 2015). Three geometries: hexagon, triangle and quadratic, has been selected to exploit shape algorithm. Morphological algorithm is based on starting from an original shape and ending with another one following algorithmic rule. This research adopts a derivative morphology following rule in figure 4 after scaling original shape based on solar exposure reading from a weather file.

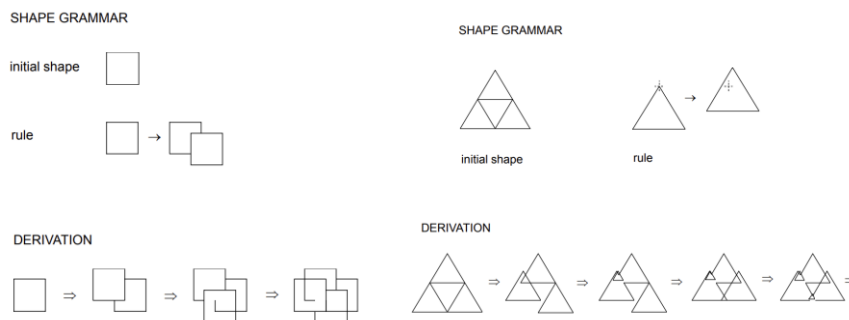

Figure 4. Shape derivation for a quadratic and triangular shapes (Knight T. , 2000)

Shape rules has been implemented on architectural plans and urban scale. descriptive and generative potential of shape grammar in order to create a parametric shape grammar for self-built incremental housing in Campinas. (Joana Tching, 2012). Moreover, Grammar rule has been the tool in heritage application as demonstrated in a generative algorithm for exploring the virtual design space of historic houses in the city of Mosul (Alani, 2018)

1.2. LEED V4.1 BENCHMARK

ASHRAE has defined certain requirements to address building envelope in which LEED V4.1 has adopted to set opaque wall percent following the building's climatic zone.

LEED V4.1 has confronted building envelope design as follow (USGBC, 2020) Comply with the recommendations in the appropriate ASHRAE 50% Advanced Energy Design Guide for all vertical fenestration.

OR • Climate Zones 1 – 2:

o Thermal Mass Enclosure: More than 50% of opaque above-grade wall area meets ASHRAE 90.1-2016 definition for “mass wall”; and more than 50% of floor area meets ASHRAE 90.1-2016 definition for “mass floor” (1 point)

AND / OR

o Demonstrate a 25% envelope UA reduction beyond ASHRAE 90.1-2016 prescriptive envelope requirements (1 point)

OR • Climate Zones 3 – 8:

o Demonstrate an envelope UA reduction beyond ASHRAE 90.1-2016 prescriptive envelope requirements:

♣ 25% UA reduction (1 point) ♣ 50% UA reduction (1 point)

Hot arid areas belong to the first climate zones category which recommends 50% of opaque massive wall. ASHRAE Standard 90.1 has requirements to address the energy used for building systems and components including energy used for heating, cooling, ventilation (S Goel, 2017). It regulates window-to-wall ratio which is devised to be 50% in the case study climate zone.

2. Methodology

This research experiments multiple morphological geometric-based design for southern-western façade of a project located at 26th July road, Giza, Egypt. Hot arid microclimatic parameters manipulate façade geometry morphology as illustrated earlier.

Morphogenesis of façade is based on shape grammar rules; rule 1, rule 2 and rule 3 as their geometric shape rules will be illustrated later, and using force-field algorithm to manipulate geo-morph façade cells as yielded in figure 8.

In rule 1, a planar façade divided into quadratic, triangular or hexagonal geometry using grid mapping to façade surface and forcefield algorithm.

Rule 2 emphasizes both concaved morphed surface of the façade itself towards sun, and morphing hexagonal or triangular cells to quadratic following solar position.

SURFACE SHAPE GRAMMAR MORPHOLOGY TO OPTIMIZE DAYLIGHTING IN MIXED-USE BUILDING SKIN

At last, rule 3 combines all three geometries in one pattern to benefit their advantages and conveying more complex aesthetic value. Pattern mapping has been applied to a planar façade followed with force-field algorithm to solar positions as delineated in figure 5.

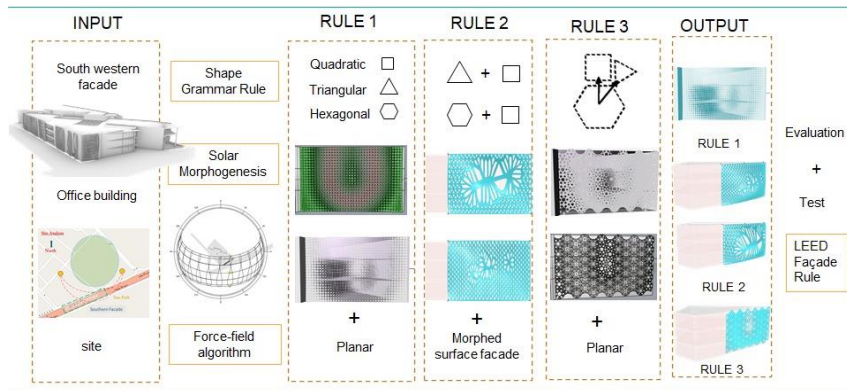

Figure 5 . Project location map with sun path elaboration

This study attempts to regulate façade solid-to-void percent following LEED benchmarks for hot arid zones. The main aim is to optimize opening for comfortable daylighting without glare and blocking excessive longwave solar radiations which cause heat stress in the pursue to follow LEED V4.1 and ASHRAE 90.1-2016 specifications in window-to-wall ratio.

2.1 GEOGRAPHIC-BASED MICROCLIMATIC PARAMETERS

A mixed-use building is located at latitude 30° 3'8.78"N and longitude 31° 3'49.94"E without neighboring development as demonstrated in figure 6. Sun path is demonstrated to reflect weather file readings while integrating microclimatic conditions towards a climatic-based morphological rule.

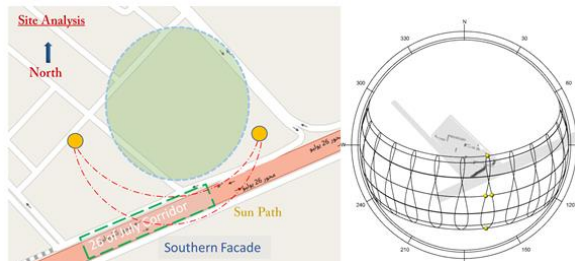

Figure 6. Project location map with sun path elaboration

This research studies the morphological typologies of façade geometries during 21 June, 21 September, 21 December, and 21 March as yielded in

figure 7. Morphing façade selected geometries is following the sun position as an attractor in a force-field algorithmic design. Cairo Weather file has been utilized to follow solar position dependent on the geographic location of the project. Moreover, Remapping tool has aided to regulate the scaling and geo-morphing of façade cells so to fit in each cell frame.

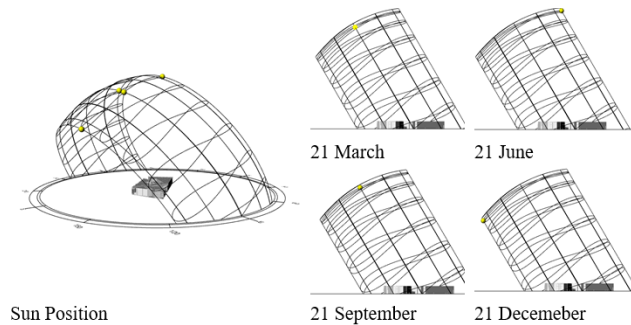

Figure 7. Sun position at 21 March, 21 June, 21 September, and 21 December at 12:00 pm

2.2. PART 1: GEOMETRY MORPHING DESIGN

A fixed grid with same number of panels and same parametric sun position readings has been implemented as inputs for attractor/ force-field algorithm. Studied geometry has reflected different glazing to solid ratio, although they are based on same parameters and rules which interprets the different responsive geo-morphing.

Geometry selection of quadratic, triangular and hexagonal cell due to geometric design variance and these geometries are frequently used in façade glazing.

Three geometric-referenced shape grammar rules have been implemented as follows;

Rule 1:

Rule 1 maintains same number of panels and almost same surface area by subdividing the quadratic into two triangles and having the hexagon inscribes in the quadratic panels assuming sharing same structural facade mullions as shown in figure 8.

SURFACE SHAPE GRAMMAR MORPHOLOGY TO OPTIMIZE DAYLIGHTING IN MIXED-USE BUILDING SKIN

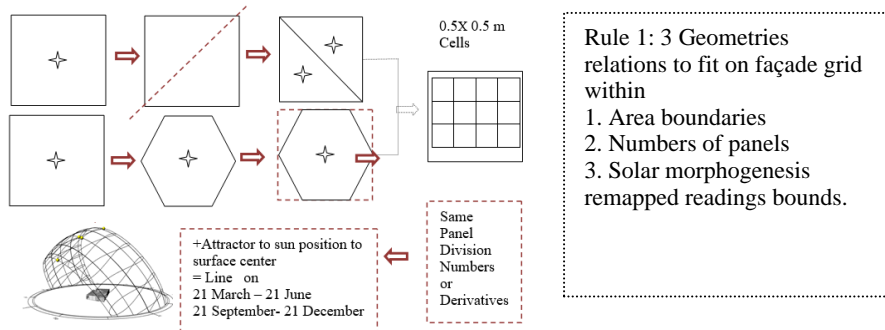

Figure 8. Rule 1: Subdivision of quadratic to 2 triangles, inscribing a hexagon in grid

Rule 2:

Another morphogenesis takes place into this rule which includes façade surface morphing to follow sun position. Moreover, geo-morph fusion from Hexagonal or triangular to quadratic referenced to solar position. Rule 2 morph the faced itself from planar to a curve using numerical relations between panels and solar position. Studied geometry is geo-morphed to a cellular fusion as yielded in figure 9.

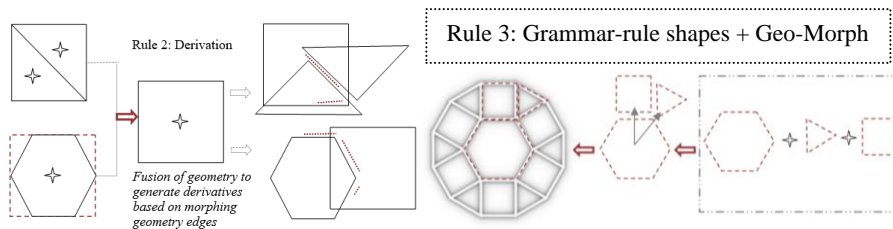

Figure 9 a. Rule 2: Geo-morph fusion rule of original geometries results, b. Morphological rule based on neighboring geometries around a hexagonal kernel

Rule 2 emphasizes the standardized concept of morphing using a source, target, and geometries to map from source to target as shown in figure 9a.

Rule 3:

A geo-morph rule based on the above neighboring algebra can be demonstrated by using a hexagon as a kernel, neighboring at the diagonal triangles, and neighboring at edges quadratics as yielded in figure 9 b representing Rule 3. Furthermore, Derivative rule can be superimposed to reinforce triangulations relationship into form rather than only neighboring at points as in figure 18.

3. Results

The main concerns that high-performance envelopes must address are insulation, conduction, solar radiation control, infiltration (air tightness), openings, and daylight. (Montes-Amoros, 2020). This research elaborates façade design morphology to optimize daylighting while blocking excessive solar radiations that maximize cooling loads. Conventional methods of using blinds, and louvres or sun breakers ideology has been adopted while enhanced to demonstrate computational geo-morphic design.

The façade of study is oriented almost south to south western with surface area 232.68 m² to follow land boundaries. The sun position through the four months on the 21 day at 12:00 pm has been utilized as an attractor to morph the façade panel. The three patterns: quadratic, triangular, and hexagonal, have responded differently although same morphological parameters and inputs are used for all as delineated in figure 11. Areas in Table 1 show panels responsive to sun position attractor by re-mapping readings to avoid overlapped units.

TABLE1 First Rule results (Using sun position as attractor) Panels Surface areas

Shape	21-Mar	21-Jun	21-Sep	21-Dec
Quadratic	134.19	135.06	134.36	132.66
Triangle	119.46	124.11	118.51	114.05
Hexagon	87.15	87.72	87.27	86.17

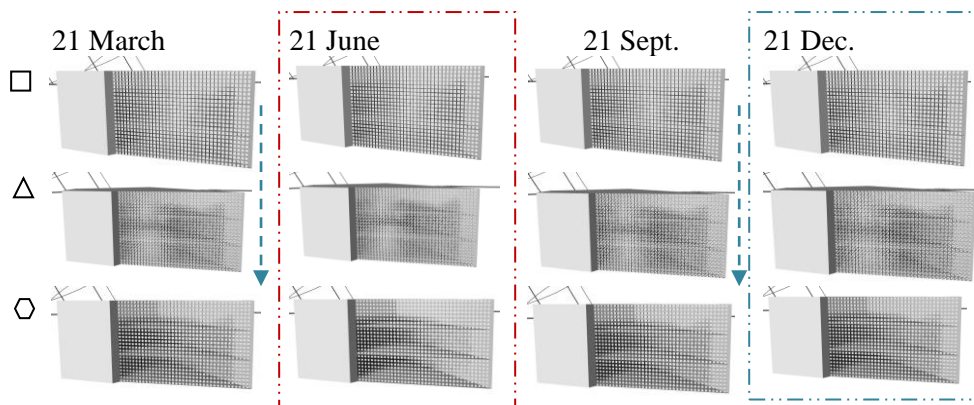

Figure 10. Quadratic, Triangular and Hexagonal Patterns geo-morphed based on sun position as an attractor

Panels surface area are increased in June, September, March and at las December consecutively. This emphasizes this research hypothesis to maximize daylight after blocking southern solar radiation as delineated in the graph in figure 12.b.

SURFACE SHAPE GRAMMAR MORPHOLOGY TO OPTIMIZE DAYLIGHTING IN MIXED-USE BUILDING SKIN

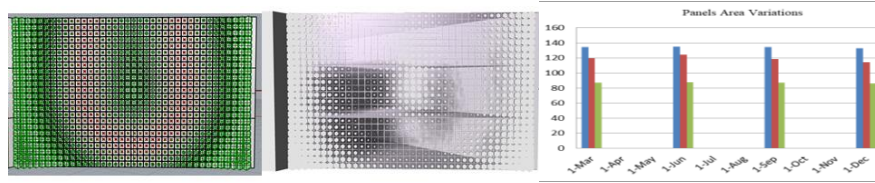

Figure 11a. Façade Geo-morph Rule 1 using different remapped pattern

b. Graph comparing Geo-morphed panels area of 3 geometries of rule 1 where blue = Quadratic, Red = Triangular, Green = Hexagon

Microclimatic readings are remapped with different pattern and used as inputs to Rule 1 as yielded in figure 15.a. Results manifest more spacing between panels allowing more daylight exposure. Repeating this same pattern on hexagonal geometry at 21 March, 21 June, 21 September, and 21 December gives areas of 76.2, 77.8, 76.0, and 74.1 consecutively.

Comparing results of implementing Rule 1 using different remap pattern on the hexagonal geo-morph has emphasized the idea of wider range in remap results in more difference in surface area throughout months from 0.25% to 0.7% increase in surface area.

Since Rule 1 promising results showing a great variation in solid-to-void percent between the 3 geometries. Rule 2 is deduced based on derivative rule demonstrated in figure 4 above to combine two shapes together. Then Rule 3 is based one combining the 3 geometries following geometric relations like orthogonal translation as in figure 3 above. Rule 2 is based on deriving irregular shapes from a regular one and morphing to a curved façade surface as yielded in figure 13. Although geometric fusion sounds tempting but results are neither feasible nor of aesthetic value.

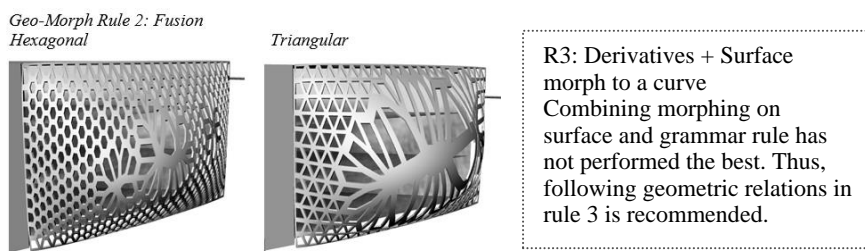

Figure 12. Rule 2: Geo-morph fusion rule of original geometries results

Rule 2 addresses free form to examine different nature of shape algebra. However, results do not meet expectations. Rule 1 has generated solid panels. On contrary, Rule 2 objective is to form structural mullions as manufacturing panels with these shapes and dimension will be difficult. Nevertheless, it won't act functionally efficient in operational use. Hence,

Rule 2 geometries fusion is not recommended and rule 3 has been conceived using 3 geometries based on geometric relations to manifest grammar systemic algorithm.

Rule 3

As delineated in figure 14, Mapping from source to target surface geo-morph rule 3 as illustrated above resembles biomimicry integration that the façade structure is stable within interlaces and related members.

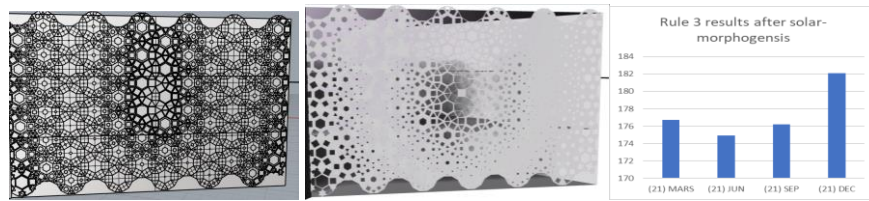

Figure 13 a. Geo-morph rule 3 on the building southern-western façade. b. Rule 3 after solar-morphogenesis of the building southern-western façade.

Total surface area of the façade is 232.86 m2. Rule 3 has elaborated geometric morphogenesis with void ration ranging from 23-25% as illustrated in table 2 which still within LEED V4.1 accepted benchmark

TABLE2 Rule 3 results (Using sun position as attractor) Panels Surface areas

21-Mar	21-Jun	21-Sep	21-Dec
176.70	174.9	176.19	182.09

Studied geometry has reflected different glazing to solid ratio, although they are based on same parameters and rules which interprets the different responsive geo-morphing. Rule 3 has interpreted grammar manifestation while following LEED V4.1 benchmark as shown in figure 19 with the utmost aesthetic, functional and structural value.

4. Discussion

A metaphoric reflection of this morphological rule of images using this research shapes is another generative algorithmic rule based on a new pattern geometry. Further grammar rules can be generated to enhancing performance, push creativity edge, and emphasizing biomimicry perfection of the tripods: form, function, and structure. Developing shape grammar rules following iterative and different algebras does not always result as

SURFACE SHAPE GRAMMAR MORPHOLOGY TO OPTIMIZE DAYLIGHTING IN MIXED-USE BUILDING SKIN

expectation. Nevertheless, recursive of successful operation within geometric relationships as illustrated in figure 15 ensures better designs and adequate performance in functionality, structure, and behavior.

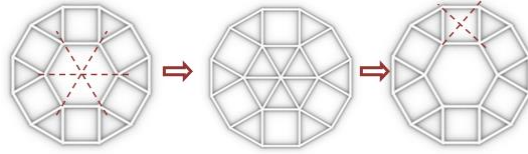

Figure 14. Morphological rule based on derivative triangulation

5. Conclusion

Facade morphogenesis enhances building envelope to optimize its response to microclimatic conditions. Adopting shape grammar rules based not only on geometric relations but also including climatic parameters reinforce geometric morphological topology to manifest integrated design.

The implementation of multiple shape grammar rules based on multiple geometries has shown that as subdivisions and number of geometry segments increases, more spacing appears giving more room to indirect daylighting while maintaining a protective shade due to multiple geometry sides. Geo-morphed panels' surface area of quadratic is more than that of triangular and the last to hexagonal with ratios Quadratic: Triangular: Hexagonal 57.6: 51.3: 37.42 percent to the façade area. Hence, considering utilizing PV cells installed on southern facades, it is recommended to use quadratic shapes. On the other hand, Rule 2 which includes a fusion of geometries to another irregular form has different results both on aesthetic, functional and structural aspects. However, creating this geo-morph rule was appealing more to authors as architects. On Contrary, Rule 3 has delineated more sophisticated results regarding LEED V4.1 building envelope percent for opaque wall (almost 25%) and following a microclimate-based geo-morph. This research has manifested microclimatic readings to manipulate shape grammar rules through a façade morphogenesis creating Geo-morph algebraic relations to enhance façade performance in compromising between required daylighting and avoided excessive solar radiations that affects cooling loads following LEED V4.1 Building envelope enhancements.

References

Ahmed R. abdeen, A. R. (2017). The role of nanotechnology in improving the efficiency of energy use with a special reference to glass treated with

- nanotechnology in office buildings. *Ain Shams Engineering Journal, Elsevier*, 2671-2682.
- Alani, M. (2018). Heritage at Stake: Computational Design Processes for. *Sigradi 2018 Technopoliticas - 22th CONFERENCE OF THE IBEROAMERICAN SOCIETY OF DIGITAL GRAPHICS* (pp. 1-5). Sao Carlos: Cumincad.
- Anant prakash, H. S. (2017). Visual Calculation Through Shape Grammar In Architecture. *International Research Journal of Engineering and Technology (IRJET) e-I*, 04(11), 293-301.
- D.Stavridou, A. I. (2015). Breathing architecture: Conceptual architectural design based on the investigation into the natural ventilation of buildings. *Frontiers of Architectural Research*, 4(2), 127-145.
- Defintion of morphology*. (n.d.). Retrieved from Merriam webster : <https://www.merriam-webster.com/dictionary/morphology>
- Eilouti, B. (2012). Sinan and Palladio: two cultures and nine squares. *International Journal Achitecture Heritage*, 6(1), 1-18.
- Eilouti, B. (2017). Sinan and Palladio: a comparative morphological analysis of two sacred precepts. *Frontier of Architectural Research*, 6(2), 231-247.
- Eilouti, B. (2019). Shape Grammars as a reverse engineering method for the morphogenesis of architectural facade design. *Forontiers of Architectural Research*, 8, 191-200.
- Franco, J. T. (2018, August 29). *ArchDaily*. Retrieved November 08, 2020, from 6 Spanish Projects That Creatively Use Louvers and Shutters in Their Facades: <https://www.archdaily.com/900756/6-spanish-projects-that-creatively-use-louvers-and-shutters-in-their-facades>
- IRENA, I. R. (2015). *Renewable Energy Outlook Egypt*. Egypt: NEREA, Egypt's New and Renewable Energy.
- Joana Tching, A. p. (2012). A Shape Grammar for Self-Built Housing. *SIGRADI 2012 FORMA (IN) FORMAÇÃO* (pp. 486-490). Brasil: cumicad.
- Knight, T. (2000, February 7). Introduction to Shape Grammar. *Introduction to Shape Grammar*. USA: MIT.
- Knight, T. (n.d.). *Introduction*. Retrieved from MIT Education: http://www.mit.edu/~tknight/IJDC/page_introduction.htm
- Montes-Amoros, V. (2020). *Curtian Walls Deign Consultant*. Retrieved from LEED Through the Eyes of the Building Envelope: LEED Through the Eyes of the Building Envelope
- S Goel, M. R. (2017). *ANSI/ASHRAE/IES Standard 90.1-2016 Performance Rating Method Reference Manual*. U.S.A: U.S. Department of Energy.
- Stiny, G. (2018, Fall). *MIT Opencourseware*. Retrieved November 08, 2020, from Introduction to shape grammar: <https://ocw.mit.edu/courses/architecture/4-540-introduction-to-shape-grammars-i-fall-2018/>
- Thyssen, A. (2013, February 15). *ImageMagick v6 Examples*. Retrieved November 08, 2020, from Morphology of Shapes: <https://legacy.imagemagick.org/Usage/morphology/>
- Tiemen Strobbe, S. E. (2016). A graph-theoretic implementation of the Rabo-de-Bacalhau transformation grammar. *Artificial intelligence for engineering design analysis and manufacturing*, 138-158. doi: 10.1017/S0890060416000032
- USGBC. (2020). *LEED v4.1 Interior Design and Construction*. USA: US Green Bulding Council.

D2.P2.S1

EMERGENT MODES OF LEARNING II

TERRITORIES MADE BY MEASURE

The parametric as a way of teaching urban design theory

DR. MATTEO FRASCHINI, DR. JULIAN RAXWORTHY

Politecnico di Milano, Milano (IT)

Email address: matteo.fraschini@polimi.it

University of Canberra, Canberra (AU)

Email address: julian.raxworthy@canberra.edu.au

Abstract. Design tools like Grasshopper are often used to either generate novel forms, to automate certain design processes or to incorporate scientific factors. However, any Grasshopper definition has certain assumptions about design and space built into it from its earliest genesis, when the initial algorithm is set out. Correspondingly, implicit theoretical positions are built into definitions, and therefore its results. Approaching parametric design as a question of architectural, landscape architectural or urban design theory allows the breaking down of traditional boundaries between the technical and the historical or theoretical, and the way parametric design, and urban design history & theory, can be conveyed in the teaching environment. Once the boundaries between software and history & theory are transgressed, Grasshopper can be a way of testing the principles embedded in historical designs and thus these two disciplines can be joined. In urban design, there is an inherent clash between an ideal model and existing urban geography or morphology, and also between formal (qualitative) and numerical (quantitative) aspects. If a model provides a necessary vision for future development, an existing topography then results from the continuous human and natural modifications of a territory. To explore this hypothesis, the “Urban Design Representation” subject in the Master of Urban Design program at the University of Cape Town taught in 2017 & 2018 was approached “parametrically” from these two opposite, albeit convergent, starting points: the conceptual/rational versus the physical/empiric representations of a territory. In this framework, Grasshopper was used to represent typical standards and parameters of modern urban planning (for example, Floor/Area Ratio, height and distance between buildings, site coverage, etc), and a typological approach was adopted to study and “decode” the relationship between public and private space, between the street, the block and topography, between solids and voids. This methodology permits a cross-

TERRITORIES MADE BY MEASURE: THE PARAMETRIC AS A WAY OF TEACHING URBAN DESIGN THEORY

comparison of different urban design models and the immediate evaluation of their formal outputs derived from parametric data.

Keywords: *Urban Design, Parametricism, Theory, Education, Models.*

ملخص. غالبًا ما تُستخدم أدوات التصميم مثل برنامج جراسهوبر إما لإنشاء أشكال جديدة أو لأتمتة عمليات تصميم معينة أو لدمج العوامل العلمية. ومع ذلك، فإن أي تعريف جراسهوبر له افتراضات معينة حول التصميم والمساحة المضمنة فيه منذ نشأته الأولى عندما يتم تعيين الخوارزمية الأولية. في المقابل، فإنه يتم بناء مواقف نظرية ضمنية في التعريفات وبالتالي في نتائجها. إن تناول التصميم البارامترى كمسألة تتعلق بالعمارة أو تنسيق الموقع أو نظريات التصميم الحضري تسمح بتفكيك الحدود التقليدية بين التقنية والتاريخية أو النظرية، والطريقة التي يمكن بها نقل التصميم البارامترى وتاريخ التصميم الحضري ونظرياته في البيئة التدريسية. بمجرد تجاوز الحدود بين برنامج التصميم البارامترى وبين تاريخ ونظريات العمارة، يمكن أن يكون برنامج جراسهوبر طريقة لاختبار المبادئ المضمنة في التصاميم التاريخية وبالتالي يمكن ضم هذين التخصصين. في التصميم الحضري، هناك صدام متأصل بين النموذج المثالي والجغرافيا الحضرية الحالية أو التشكل، وأيضًا بين الجوانب الشكلية (النوعية) والجوانب العددية (الكمية). إذا كان أي نموذج يوفر رؤية ضرورية للتطور المستقبلي، فإن الطبوغرافيا تكون في تلك الحالة ناتجة عن التعديلات البشرية والطبيعية المستمرة لأي إقليم. لاستكشاف هذه الفرضية، تم تناول موضوع "تمثيل التصميم الحضري" في برنامج ماجستير التصميم الحضري في جامعة كيب تاون الذي تم تدريسه في عامي 2017 و 2018 "بشكل حداثي" انطلاقًا من هاتين النقطتين المتعارضتين، وإن كانتا متقاربتين، وهما: المفاهيمي / العقلاني مقابل التمثيلات المادية / التجريبية لإقليم ما. في هذا الإطار، تم استخدام برنامج جراسهوبر لتمثيل المعايير النموذجية للتخطيط الحضري الحديث (على سبيل المثال، نسبة الأرضية للمساحة، والارتفاع والمسافة بين المباني، وتغطية الموقع، وما إلى ذلك)، وتم اعتماد نهج تصنيفي للدراسة و"فك الشفرة" العلاقة بين الفضاء العام والخاص، بين الشارع والكتلة والطبوغرافيا، بين الكتل والفراغات. تسمح هذه المنهجية بإجراء مقارنة بين نماذج التصميم الحضري المختلفة والتقييم الفوري لمخرجاتها الرسمية المستمدة من البيانات المعيارية.

الكلمات المفتاحية: *التصميم الحضري، البارامترية، النظريات، التعليم، النماذج المعمارية.*

1. Introduction

Inherently mathematical and graphical, parametric design tools use data to either generate novel forms, to automate certain design processes or to incorporate quantitative factors in the analysis and design process. In contrast, history and theory is textual and qualitative, more about abstract ideas and historical contexts than design or data. Approaching parametric design as a question of architectural, landscape architectural or urban design theory allows for the breaking down of traditional boundaries between the technical, and the historical or theoretical, allowing both to be delivered meaningfully in the teaching environment. Once such boundaries are transgressed, parametric design can be a way of testing the principles embedded in historical designs, and the two areas joined.

This paper describes and reflects on a novel teaching model experimented with in the delivery of a new Master of Urban Design program at The University of Cape Town (UCT) in 2017-2018, which used parametric

thinking and tools – Rhino/Grasshopper – to explore historical material, by linking two normally discrete subjects: Urban Design Representation and Urban Design Theory. The rationale for this linkage from the perspective of history & theory was that many models studied in the Urban Design Theory subject – particularly those from the 19th century – are inherently parametric in their use of rules, and from the perspective of representation, Grasshopper allowed a comparatively easy testing of such rules at a large scale, to both understand their urban implications and also potential limitations. By doing so, parametric tools – taught in the former subject – were used to discuss and deepen specific theoretical and practical concepts related to the discipline of urban design – discussed in the latter.

Modelling is fundamental to urban design, as David Grahame Shane notes, because “a city model enables a designer to construct an understanding of the city and its component elements, facilitating design decisions,” (Shane, 2005, p. 13) however, at the same time, such models are always deficient because “urban actors now deal inevitably and everywhere with urban situations that are heterogenous and mixed, not simple and pure.” (Shane, 2005, p. 11) To mitigate this contradiction, Jonathan Barnett proposes that “city design requires a control system that is strong enough to preserve the original concept and flexible enough to be adaptable as situations change.” (Barnett, 2016, p. 10) The system described by Barnett could be a parametric model, where the “original concept” is the model and the “adaptability” is the ability of the model to flex with different input values.

Parametric urbanism has been written about extensively elsewhere by Fosero et.al. (2013), Tom Verebes (2014) and Olgu Çalışkan (2017) – amongst others – following Patrick Schumacher’s (2009) proposition that the parametric is the style of the 21st century, in not just architecture, but also urban design. In contrast, our teaching approach – by combining history and theory of urban design, with teaching parametric tools – aims to demonstrate how many historic urban design models since the 19th century can be studied using digital/parametric tools, and can be opened up by defining their key relationships, using what Oxman calls “parametric design thinking.” Once defined, students can then explore how their historical prototype can change by modifying values to “create an infinite range of topological versioning types that can be mediated by parametric modifications of associative relationships.” (Oxman, 2017, p. 16) In this way, students learn about the urban model not simply as a historical phenomena with a particular configuration, but the formal and metrical relationships that drive the model, and how they might be adapted, making historical knowledge available for design. Despite the novelty of parametric tools, a similar method was used at the Ecole des Beaux-Arts, for example by Durand who “tailored traditional arrangements to accord with his own ideals, reducing all compositions to

TERRITORIES MADE BY MEASURE: THE PARAMETRIC AS A WAY OF TEACHING URBAN DESIGN THEORY

standardized, elementary forms... made up of a repetitive pattern of basic units.” (Szambien, 1982, p. 21).

From the Industrial Revolution onward increasing attention was given by architects to the conditions of worker housing resulting from rapid migration to fast-growing cities, which Benevolo (1967, 44) suggested translated into an exercise of balancing aesthetic Baroque canons with quantitative data. Correspondingly, the use of parametric technologies can be seen as a useful method to unpack and carefully evaluate the dichotomy of ‘quantity and quality’, allowing, for example, Durand’s *pattern of basic* [discrete] *units* to be studied in almost infinitesimal variations (Shelden and Witt 2014). Key to opening up history in this way is a requirement to understand the parametric tools available to undertake the task, where the process of learning the tool therefore also reinforces the understanding of the model, because the model must be interrogated to understand its basic relationships, to then “unpack” them into the definition. Correspondingly this paper is focused on this “unpacking process”, where three urban design models are explored differently on the basis of the disciplinary background of the authors who taught together: Top-Down/Inside-Out, reflecting an architects reading of the urban (2.1 & 2.2); and Bottom-Up/Outside-In, reflecting that of the landscape architect (2.3).

2. Parametric definitions; historical urban models

2.1. MULTIPLICATION: ZEILENBAU

An introductory exercise for the subject focused on the key concepts of the “functional” city, developed by CIAM (Congrès internationaux d’architecture modern), using the *Charter of Athens*, originally developed in 1931 (Le Corbusier, 1973), as a guide. These concepts were codified and recombined in the definitions developed, which allowed students to understand how the modernist city as a whole was conceptualized. While Shane notes that the Modernist city resembled 19th-century Beaux-arts Cartesian planning systems (Shane, 2005, p. 111) – similar to the two 19th century city definitions that follow in the paper, allowing all three to be cross-comparable – the functional city was driven by an attention to the human scale as a starting point for planning at an urban scale and was a rationale for the overall rethinking of the city.

The *Charter of Athens* and its interest in human scale derived from a critique of the living conditions of the working class provided by the 19th century city (Frampton, 1980), in particular, poor hygiene, as noted in the Charter (Le Corbusier, 1973, p. 53):

- An inadequacy of habitable space per person;
- A mediocrity of openings to the outside;
- An absence of sunlight (because of northern orientation or as the result of shadow cast across the street or into the courtyard);
- Decay and a permanent breeding ground for deadly germs (tuberculosis);
- An absence or inadequacy of sanitary facilities;

In the Charter's conclusions, it proposed that "the initial nucleus of urbanism is [therefore] a cell for living - a dwelling and its insertion into a group forming a habitation unit of efficient size." (Le Corbusier, 1973, p. 101) From this, the domestic residence – formally defined and functionally distinct – assumed a fundamental role, for which natural lighting was regarded as a vital factor. The base living cell of this *Existenzminimum* (as it was also known) could then be multiplied according to specific rules to create buildings, then the city.

Excessive and unregulated density was a feature of historic buildings of many European cities, which created poor natural lighting and ventilation and consequent hygienic problems inside the apartments or rooms. The Athens Charter critique and the models resulting from it represented the end of the 19th century perimeter bloc, meaning that the streetscape was no longer defined by buildings. Buildings became elevated on piloti, leaving the ground virtually free for the use of pedestrians, the city changing from a grid system made up of points and lines (akin to Lynch's Nodes and Paths) to a continuous two-dimensional surface.

Models arising from this cellular approach during the modern period emphasized optimizing ventilation and sun exposure, and included: studies by Adolphe-Augustin Rey, Justin Pidoux and Charles Barde on the ideal orientation of buildings based on the optimization of the sun and the creation of a solar thermal axis (Rey, Pidoux and Barde, 1928); the Zeilenbau schemes by Walter Gropius that optimized natural lighting by modifying building spacing (Frampton, 1980); and Mies Van Der Rohe's Weissenhof Estate in Stuttgart in 1927 (Johnson, 1953, p. 44).

Mies's Weissenhof Estate was used as the model to highlight and decode these characteristic measures and values for the first exercise in the "Urban Design Representation" subject, featuring parallel residential buildings where the apartments are organized within a defined structural grid. Within this grid, Mies's experimentation highlighted the possibility of different variations in the apartment's distribution, based on the identification of a "minimal" structural cell that organizes linear development, which can essentially be infinitely repeated. The importance of this project, within the experimentation of the modern movement, showed the potential of obtaining different distribution solutions within a typologically and structurally defined module, though for the exercise, the variations inside the apartments

TERRITORIES MADE BY MEASURE: THE PARAMETRIC AS A WAY OF TEACHING URBAN DESIGN THEORY

was not considered. However, the basic module and how it was aggregated and multiplied to create the apartment block vertically was important, because this defined the shade it would cast, working from small to big.

The “Urban Design Representation” exercise (Figure 1.) involved determining parameters for controlling control the optimal lighting and ventilation values of the apartments at the scale of the urban block, rather than the scale of the architectural dwelling. In the definition:

- The algorithm multiplied the cell unit – in the Weissenhof case, the cell was 2.5 x 2.5m – to create an apartment block of a certain height.
- A part was added to the definition that related height and distance between buildings in order to define the shadow line, using an angle variable (in this case 38 degrees), which defined the offset of the apartment block.

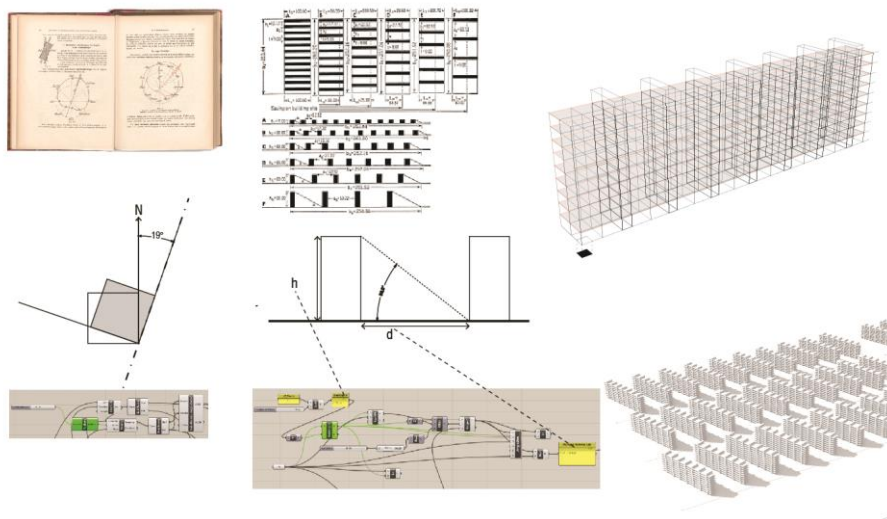

Figure 1. Historical references and coding (left-top). Definition of the algorithm according to basic modernist parameters, related to solar exposition and structural modulus (left-bottom) and resultant array of model on site (right).

Once the parameters were determined and the algorithmic relationships modelled, the value of the exercise from a design perspective laid in exploring and testing a planning “metric” through the definition: a housing unit/type with specific functional characteristics and the particular impacts, and opportunities, that metric has at the urban scale.

A key characteristic of the Master in Urban Design program at UCT was that it admitted students from disciplines outside architecture – such as landscape architecture and planning – so not all students had a thorough

knowledge of the particular problems of architectural design. Correspondingly, although this model as it was defined by its Modernist architectural authors was inherently Top-Down/Inside-Out in this exercise the scale of the building and the complexities associated with its design were instead addressed at the level of urban scale rather than building planning, making the result operate Bottom-Up/Outside-In. In this context, the decoding of characteristic measures or dimensions, like Mies's module in this exercise, without having to study building planning in detail was a useful approach for students from outside architecture.

2.2. ARRAY: CERDÀ'S EIXAMPLE

Ildefons Cerdà's Barcelona Eixample from 1860 is inherently parametric in how Cerdà conceived it, and developing a definition of it in the "Urban Design Representation" course therefore allowed the introduction of key urban design elements and issues. The Eixample model is as a paradigmatic way of thinking about the industrial city where the rapid growth of settlements, a new type of society and the advent of new means of transport required a different urban design approach. Key to this paradigm are the following distinctive features:

- The block, and the definition of its basic measures and the density ratios
- The resulting street cross-section
- Grids and grid deformations at different scales and with different measures
- The Avenida / Rambla as a subtractive armature

Cerdà's model had a very specific numerical and quantitative nature, so the starting point of the "Urban Design Representation" exercise was Cerdà's design and theory from the time, (Ferguson, 1997, p. 118) not what was actually built, which has a considerably higher density. For the purposes of the exercise, the basic unit or metric of the model was the block. According to Cerdà's thinking, the block was the "scientific" result of smaller housing measures with standard dimensions as a repeatable and multipliable element, and in this sense is not radically different in essence to that of the previous Zeilenbau example used earlier in the subject.

The specific measures of the block defined by Cerdà that were used to define the algorithm were (Figure 2.):

- A 113 m square block, with chamfered corners with a side of 20m
- A distance between the blocks of 20 m (with 5 m of pavement on each side).
- Within the block, a constructed area of 50% was proscribed so that buildings, at least on two sides, defined the perimeter of the block and its street section.

TERRITORIES MADE BY MEASURE: THE PARAMETRIC AS A WAY OF TEACHING URBAN DESIGN THEORY

These measures define a base grid that parametrically allowed multiplication to create the base block. Examining Cerdà's studies for the final design at the time highlighted his desire to relate the size of the block to the housing units and the population density per square meter within the block.

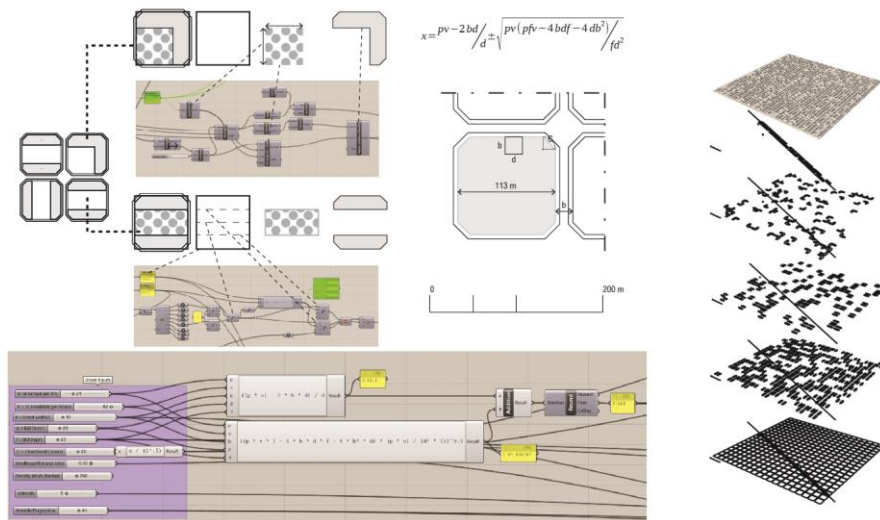

Figure 2. Translation of Cerdà's rules into Grasshopper (left). Density in relation of the original Barcelona's perimeter block. Definition of urban elements at different scales (right).

The algorithm was enriched by other elements explored through compositional strategies and arrangements, notably a series of streets which, although aligned with the grid, had greater width and create 'interference' in its pattern, in particular Avenida Diagonal. These 'exceptions' of the rule in the model were particularly important, since, in the planning of the industrial city they defined public space at the scale of the metropolis, through an "armature" as defined by Grahame Shane which, subtracted from the grid, connects it to the territorial scale, linking other towns that were to be joined as part of the proposal. For the purposes of the "Urban Design Representation" exercise, these exceptions demonstrated that abstract models require adjustment to allow them to become site specific and to deal with existing urban features to be retained, an important urban design lesson.

The interpretation of the model for the Grasshopper definition was based on the following parameters:

- *The Urban Block* defined by a mathematical equation that systematizes the linear dimensions of the buildings, floor area ratio, density and the

number of floors, the base chamfered in order to obtain the diagonal side of 20m

- *The Grid*, at small and medium scales, defined in its basic dimension as the sum of the width of the block and the road (for example 113m + 20m, respectively). Cerdà's scheme indicated an overlap of a road mesh with a wider section. This grid was originally irregular, but been regularized in the model: every 5 blocks there is a “wide” road.
- *Block Variation*, where the coverage ratio is defined so that 50% of the surface is free. Within the perimeter of the block, Cerdà offered two types of ‘opening’, which was used in the definition to perform a subtraction of half of the total surface in two different ways: the first, two parallel building rows, and; the second, the “L” shaped building footprint. Both types follow the perimeter of the block. The built part of the block is obtained by extruding the remaining surface. In the model, the types are rotated and arranged “randomly” within the grid.
- The *Avenida Diagonal* is a “carved” subtraction from the existing grid pattern. Each operation is undertaken on planar surfaces / regions and the resulting blocks that have a surface smaller than a certain value (variable and controllable) are excluded from the extrusion. In this way the built rows that emphasize the Diagonal have their own part of the definition superimposed and then joined to the grid.

Although this model was still based on a block generated from an architectural point of view – an example of the Top-Down/Inside-Out approach – the block in this model was also essentially in service of the creation of street infrastructure and public space at the grid intersections, and therefore also has Bottom-Up/Outside-In aspects.

2.3. EXTRUSION: HAUSSMANNIZATION

The characteristic urbanism of Paris – its boulevards – arises from the work of Georges-Eugène Haussmann (1801-1891) for Napoleon III during the Second Empire (1853-1870) in France, together with his engineer lieutenant Jean-Charles Adolphe Alphand (1817-1891). In the 19th century, when the work of Haussmann was either admired or deplored, his work was not simply a particular series of projects but was a type of practice, which Ferguson reminds was called “Haussmannization” from 1892 onwards, an “umbrella concept” that “designate[d] every topographical alteration or social change that marked Paris during Haussmann’s tenure as prefect of the Seine.”(Ladd, 2014, p. 60) The root of Haussmannization is “an escape from the darkness and enclosure of the metropolis” through the creation of a “pleasing visibility, in the street itself as well as down the street’s axis to some more or less distant monument,” the topographic act Ladd describes linking existing spaces and monuments, where such “visibility accompanied

TERRITORIES MADE BY MEASURE: THE PARAMETRIC AS A WAY OF TEACHING URBAN DESIGN THEORY

circulation—of light and air, of people on foot but especially on horses and in wheeled vehicles.”(Gresset, 1993, p. 33) This transition from “darkness and enclosure” to a state of “light and air” – tied to ideas of the time about urban hygiene that persisted in the Modernist *Charter of Athens*, described in 2.1 – used the street as a tool to open up the old city.

Hausmannization is inherently a kind of parametric practice. This practice is embodied in Gressett’s description of Hausmann and Alphand’s basic operation as “la coupure verte,” a “Green Cut” (Gresset, 1993, p. 30). The terms in Green Cut show an outline of a Grasshopper definition that comprised a dynamic between the two words. The “cut” part of the definition starts with an existing city, a “topography”, the “science or practice of describing a particular place,” (‘topography’, 2020) that was cut into – a Rhino block model of extruded polygons traced from a map to create a solid – and “existing spaces and monuments” – that were points in Rhino. In the “Urban Design Representation” subject, the workflow of referencing geometry from Rhino to Grasshopper was an urbanism and practice analogy of working from the world to the model that corresponded to the Bottom-Up/Outside-In approach, the , the opposite of the Top-Down/Inside-Out strategies from the previous sections 2.1 and 2.2.

Once these existing “topographies” were referenced in Grasshopper, the monument/points became endpoints for lines that represent Ferguson’s “ax[es] of streets,” providing the rail for a first sweep that cuts from the solid city mass – the “Cut” component – and then for a second sweep that creates a streetscape – the “Green” component. These two parts were tied to each other since the size of the cut was tied to the requirements of the streetscape configuration, though the cut was necessarily made first. Two drawings at different scales show how the operation of the cut worked in practice (Figure 3). The first, at a large scale, features a pre-Hausmann map of Paris, over which Hausmann’s main connective lines are superimposed – the rails in the definition – which focus on the location of the monuments to be linked. The second drawing – zoomed in, with the actual buildings cut through – show the localised impacts of the cut. Treated parametrically, this definition in Grasshopper operated like Hausmann, since the autonomy and perfection of the straight cut action is prioritized over the impacts, and was not adjusted due to those impacts, the Boolean subtraction cutting across anything that it intersects with, without exception, in a manner similar to Cerda’s Avenida Diagonal.

While Hausmann’s urban intentions were significant to the history, theory and practice of urban design generally, when combined with the achievements of his lieutenant, the engineer Adolphe Alphand, they gain a landscape architectural dimension, set out in his book *Les Promenades de Paris*. With an emphasis on public space Alphand’s was a useful approach to

contemporary urban design practice, particularly “the boulevards [which] become the privileged urban places of a Paris conceived as a “city of the outside,” as Gresset (1993, p.33) notes and specifically the Boulevard Richard Lenoir was very important because it “enhanced the circulation spaces which were specific to the nineteenth century,”(Gresset, 1993, p. 33) and was a prototype for turning traffic infrastructure into a new type of recreational space. Gresset described Boulevard Richard-Lenoir as a “thick and complex urban floor” which comprised “the circulation of pedestrians and cars, on either side of the central planted promenade.”¹ Drawings from this period show this “floor” in detailed sectional etchings with a whole range of urban elements calibrated to these different functions.

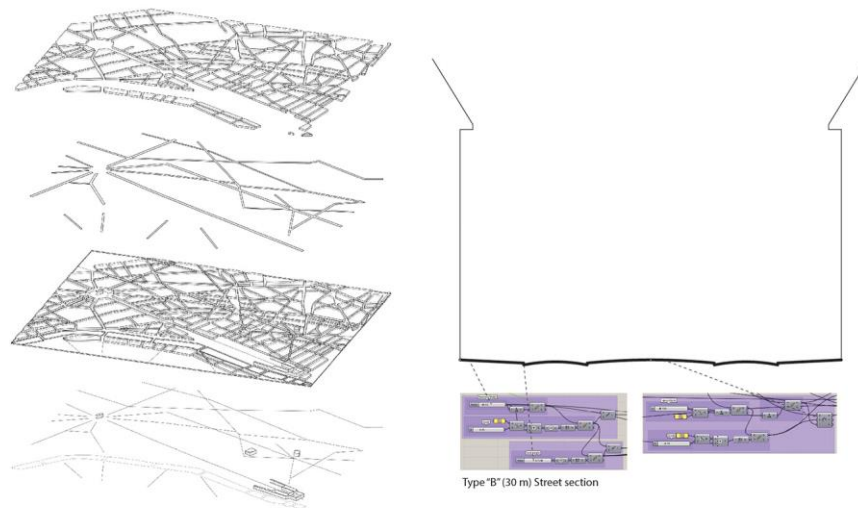

Figure 3. Definition of Urban Elements in the Haussmann Plan for Paris: Existing Urban Fabrics, Monuments and Boulevards (left) & different types of street section/subtraction (right).

In the Grasshopper definition of the “Green” component, after the “Cut” was made, the specific streetscape section was produced as an extrusion inside the cut void. Designing this definition of the streetscape was about systematizing the creation of the section, where the organization of the definition is organized to move across the street and all the different functional surfaces that make it up. Sliders for widths of sidewalks, roads and medians, each with their own heights of curbs and crossfalls created a continuous section line. This sectional approach to the street which Alphant

TERRITORIES MADE BY MEASURE: THE PARAMETRIC AS A WAY OF TEACHING URBAN DESIGN THEORY

developed is now the basis for contemporary streetscape design, and indeed the NACTO (National Association of City Transportation Officials) *Global Street Design Guide* (2016) features sections that are also described parametrically. Such a parametric approach has also been demonstrated in the recent book *Paris Haussmann* (2020) from the exhibition at the Arsenal in Paris. Measures in the definition allowed for multiple iterative testing of the different configurations that show this continuity from Alphand's method to contemporary sectional methods of composing the street.

3. Conclusion

The exercises presented in this paper defined a comparative methodology between different approaches to urban design. The three urban models "parametrically" discussed here offer a common ground for qualitative and quantitative comparisons and understanding of their implications. This allows for an expansion of the spectrum of urban design operations by defining codified measures that make them comparable with each other, tending toward strictly formal definitions linked to specific theoretical concepts.

Foundational courses in a Master of Urban Design program generally include theory and history of urban design, which we have focused on and demonstrated the value of a parametric approach to study this topic. However urban design studio, which requires a student to design or redesign a piece of city and territory, is also a key component, must include existing topographical conditions, that are more difficult to operate on with the kind of methods we have described, that are also inherent in the models discussed. A limitation of this approach therefore is that if urban design concerns are not describable formally, models cannot be made using Grasshopper definitions and are therefore also not comparable, potentially limiting the scope and value of parametric urbanism. The applicability of urban design models in existing physical contexts requires further experimentation through parametric urban analyses as a verification tool.

Although this paper essentially talks about methodology and the relationships between model and theory, our experience is useful for framing educational approaches that make historical urban design models available, albeit abstractly. The study of urban design representation methods helps to approach a "theoretical" vision and its practical application. The application of these models offers further stimuli for reflection which, we have demonstrated, can be "codified".

References

- BARNETT, J., 2016. *City Design: Modernist, Traditional, Green and Systems Perspectives*. 2nd ed. New York: Routledge.
- BENEVOLO, L., 1967. *The Origins of Modern Town Planning*. London: Routledge
- CALISKAN, O., 2017. Parametric Design in Urbanism: A Critical Reflection. *Planning Practice & Research*, 32(4), pp. 417–443.
- CERDÀ, I., 2018. *General Theory of Urbanization 1867*. Edited by V. Guallart. ACTAR.
- FERGUSON, P. P., 1997. *Paris as Revolution: Writing the Nineteenth-Century City*. Berkeley: University of California Press.
- FRAMPTON, K., 1980. *Modern Architecture: A Critical History*. New York: Oxford University Press.
- FUSERO, P. ET AL., 2013. 'Parametric Urbanism: A New Frontier for Smart Cities', *Planum the journal of urbanism*, 2(27), pp. 1–13.
- GRESSET, P., 1993. 'De l'agora à l'espace public', in Starkman, N. (ed.) *Paris Projet: Espaces Publics*. Paris: Atelier parisien d'urbanisme, pp. 24–33.
- JALLON, B., NAPOLITANO, U. AND BOUTTÉ, F. eds. 2020. *Paris Haussmann: A Model's Relevance*. Paris: Park Books, in cooperation with Editions du Pavillon de l'Arsenal.
- JOHNSON, P., 1953. *Mies van der Rohe*. New York: Museum of Modern Art.
- LADD, B. (2014) 'The Closed Versus the Open Cityscape: Rival Traditions from Nineteenth-Century Europe', *Change Over Time*, 4(1), pp. 58–74.
- LE CORBUSIER, 1973. *The Athens Charter*. Translated by A. Eardley. New York: Grossman Publishers.
- NACTO. *Global Street Design Guide*. Island Press, 2016.
- OXMAN, R., 2017. 'Thinking difference: Theories and models of parametric design thinking', *Design Studies*, (52), pp. 4–39.
- REY, A.-A., PIDOUX, J. AND BARDE, C., 1928. *La Science Des Plans de Villes. Ses Applications à La Construction, à l'extension, à l'hygiène et à La Beauté Des Villes*. Lausanne: Payot & Cie.
- SHELDEN, D.R., AND WITT, A.J. 2014. 'Continuity and Rupture'. In *Theories of the Digital in Architecture*, edited by Oxman and Robert Oxman. London: Routledge, Taylor & Francis Group, pp. 1–9.
- SCHUMACHER, P., 2009. 'Parametricism: A new global style for architecture and urban design', *Architectural design*, 79, pp. 14–23.
- SHANE, D. G., 2005. *Recombinant Urbanism: Conceptual Modelling in Architecture, Urban Design, and City Theory*. Chichester: John Wiley & Sons.
- SORIA Y PUIG, A., 1995. 'Ildefonso Cerdà's General Theory of 'Urbanización'', 66(1), pp. 15–39.
- SZAMBIEN, W., 1982. 'Durand and the continuity of tradition', in Middleton, R. (ed.) *The Beaux-Arts and nineteenth-century French architecture*. London: Thames & Hudson, pp. 19–33.
- 'topography', .2020. *OED Online*. Oxford University Press. Available at: www.oed.com/view/Entry/203423 (Accessed: 4 November 2020).
- VEREBES, T., 2014. 'A New Toolbox for Adaptive Masterplanning', in Verebes, T. (ed.) *Masterplanning the Adaptive City*. London: Routledge, pp. 142–152.

CASE STUDIES OF INCORPORATING BIM MODELS IN THE DIGITAL GAME ENVIRONMENT

Building Game Environment with BIM Tools and Game Scripts

VELİ MUSTAFA YÖNDER

Faculty of Architecture, İzmir Institute of Technology, Turkey

Email address: velimustafayonder@gmail.com

Abstract.The emerging video game industry has provided opportunities for innovation and transformation starting with the late 20th century. In line with ever-changing needs and increasing demand, the extent of the digital gaming industry has outreached to the education sector and its subdomains besides the entertainment industry and its subbranches as users obtain ambidextrous achievements through the gamification processes in which an experimental learning environment is formed naturally. Numerous dissimilar disciplines from engineering, architecture, construction, work safety, renewable energy, education, and health, etc. train users thru educational simulations prepared in digital environments to amplify their learning processes. Undoubtedly, the fields of architecture, engineering, and construction (AEC) are gradually adapting to the conditions of accelerating digitalization efforts in this era. Thus, BIM technology being one of the common denominators of the digitalization efforts in those fields serves the diverse agenda of the users with increasing popularity. Professional interaction and education may greatly benefit from conjoining the model outputs of BIM technology and interactive visual fidelity of the digital gaming industry. This ongoing research project aims to develop and compare two different BIM-based models of the historic Çardak Khan and the contemporary student center building by creating sophisticated digital game environments with architectural educational space-based informative scenarios. Space-based virtual cards were created for each scene. Research results in response to the diversity of spaces, geometric qualities, number of scenarios and sequences were reported. Furthermore, textual data such as game scripts and drafts were analysed with Voyant Tools.

Keywords: *BIM, Game Environment, Digital Game-Based Learning, Game Script*

ملخص. أتاحت صناعة ألعاب الفيديو الناشئة فرصاً للابتكار والتحول بدءاً من أواخر القرن العشرين. تماشياً مع الاحتياجات المتغيرة باستمرار والطلب المتزايد ، توسعت صناعة الألعاب الرقمية لتشمل قطاع التعليم ومجالاته الفرعية وكذلك صناعة الترفيه والشركات التابعة لها حيث يكتسب المستخدمون إنجازات بارزة من خلال عمليات التحفيز التي يتم فيها التعلم التجريبي. وتتشكل البيئة بشكل طبيعي. تقوم العديد من التخصصات المختلفة من الهندسة والهندسة المعمارية والبناء وسلامة العمل والطاقة المتجددة والتعليم والصحة وما إلى ذلك بتدريب المستخدمين من خلال عمليات المحاكاة التعليمية المعدة في البيئات الرقمية لتضخيم عمليات التعلم الخاصة بهم. مما تتكيف تدريجياً (AEC) لا شك فيه أن مجالات الهندسة المعمارية والهندسة والبناء هي BIM مع الظروف لتسريع جهود الرقمنة في هذا العصر. وبالتالي ، فإن تقنية واحدة من العوامل المشتركة في جهود الرقمنة في هذه المجالات وتخدم الأجندة المتنوعة للمستخدمين بشعبية متزايدة. قد يستفيد التفاعل والتعليم المهني بشكل كبير والإخلاص المرئي التفاعلي لصناعة BIM من الجمع بين مخرجات نموذج تقنية الألعاب الرقمية. يهدف هذا المشروع البحثي المستمر إلى تطوير ومقارنة نموذجين التاريخي ومبنى مركز الطلاب Cardak Khan لمبنى BIM مختلفين يعتمدان على المعاصر من خلال إنشاء بيئات ألعاب رقمية متطورة مع سيناريوهات وسائط تعليمية ومعمارية وفضائية. يتم إنشاء بطاقات افتراضية للفضاء لكل مشهد. تم الإبلاغ عن نتائج البحث استجابة لمجموعة متنوعة من المساحات والهندسة وعدد السيناريوهات والتسلسلات. تم تحليل البيانات النصية مثل نصوص اللعبة والمسودات باستخدام Voyant أدوات.

الكلمات المفتاحية. نمذجة معلومات المبنى، بيئة اللعبة، التعلم الرقمي القائم على اللعبة، سيناريو اللعبة.

1. Introduction and Problem Statement

Comprehensive digital game design involves the generation of parameters with multidimensional and complex relationships and their rational synchronization. The evolution of the digital game world with a recent past continues to enrich in graphical standards as well as content types. In particular, educational computer games have been used as multi-faceted instruments that combine educational and entertaining features that have been around for a long time. While there is a potential in utilizing computer games for education purposes, factors such as underrated interest and relatively meager development hinder the adoption of computer games in education and training fields (Simkova, 2014). Moreover, these digital games offering educational simulations assist traditional learning environments. The enticing context offered in those digital platforms fosters children's participation effectively while its success is merely bound to effective integration within the game (Fisch, 2005).

The gamification process can be oriented for both the education of students and the training of professionals. Especially there are numerous virtual

CASE STUDIES OF INCORPORATING BIM MODELS IN THE DIGITAL GAME ENVIRONMENT

games made on various subjects for those studying and working in the field of architecture, engineering, health service, military service, building maintenance, design quality, architectural visualization, construction, etc. A study by Yan et al.(2011) which contextualized architectural design and visualization, offered collocation of BIM platform and gamification steps to create a framework for user interaction in the virtual built-environment. In terms of engineering education, game scripts and the use of artificial environments have proved their positive impact on the learning process (Dinis et al., 2017). Similarly, Marlow (2009) appreciated the high potential of using digital games in landscape architecture education as class content transmit was regarded as more immersive to the students. Finally, Ruppel and Schatz (2011) explored the effectiveness of BIM-based “Serious Human Rescue Game” simulations and virtual game environments in the training process.

Building Information Modelling (BIM) technologies are used by project stakeholders for various purposes in dissimilar scales. The project teams can generate and exchange design information in 3D (Kubba, 2012) at the "schematic design (SD), detailed design (DD), and construction detailing (CD)" phases (Azhar et al., 2015). Thus, at the design stage, several strategies that make use of competent virtual models in order to find rational solutions to difficulties could be exerted. Furthermore, it allows the flow of semantic information such as qualitative information and geometric representations of building components between stakeholders within its framework. The BIM platform also provides tools for architectural representation and animation operations as well as building commissioning that requires as-built models. Besides, “as-built BIM is particularly helpful for the restoration, documentation, and maintenance of existing buildings” (Macher et al., 2015). Addedly, the study of Murphy et al. (2017) outlines a complete workflow of integrating BIM models of historic buildings (HBIM) with a game engine. The preparation of detailed architectural presentations and educational simulations of historic buildings, in particular, holds significance for passing cultural heritage (CH) knowledge onto future generations.

In order to bring BIM tools to the next level in terms of interaction and discover their educational benefits in digital architectural education, it is of significance to solicit the integration possibilities with the game engines, which in part complement our transforming lifestyle commencing with the COVID-19 outbreak. Thus, in this study, the effect of marrying a BIM environment with a digital game platform will be examined by touching on the following problems as noted below:

- ❖ Can BIM software be used effectively in the creation process of game spaces for architectural educational purposes?

- ❖ What are the difficulties encountered when constructing models in the HBIM environment to a game engine?
- ❖ Is there a meaningful link between serious games and BIM tools in terms of designing game environments?
- ❖ What are the considerations when writing a game script for restitution models?

2. Background of the Contextual Framework

The digital gaming industry offers various types of games suited for different purposes shaped by the expectations of users. Among those, “serious games” for educational purposes have gained the attention of both manufacturers and consumers. However, unpopularly, slow adoption and rather underrated value of game-based learning pose a challenge in the education domain while game-based learning has been around for several decades and is regarded barely a novel approach (Egenfeldt-Nielsen 2010, p.142). Characteristics of gaming can be implemented over the education process to create a motivating, facilitating, amusing way of learning with reflective attributes (Mininel et al., 2009). For education and training purposes, game-based learning sets an outline for a player to experience a pre-designed script that demands a series of complex user reactions and interactions while superimposing certain identity and feeling (Squire, 2008). Moreover, Vocaturio et al. (2019) signify that the design of any game is strictly bound to three main principles, namely: “challenge, response, and feedback”.

Several studies were carried out to understand the roots and historical development of the serious game genre (Djaouti et al., 2011). Yet there has been no consensus of academia and industry on the definition of the digital serious game (Laamarti et al., 2014). Although the term “game” is generally recalled with its entertainment aspect at first glance, its remarkable benefit has been recognized widely in different disciplines and the scientific community in the form of educational and instructional games. The concept of digital serious gaming allows the user to serve a specific scientific aim during gameplay, so it fulfills both the video game and practical functions (Alvarez and Djaouti, 2011).

In addition to theoretical training, practical internship programs are present in the current curricula of the architecture, engineering, and construction (AEC) domains. As such, digital games geared to consolidate both theoretical and practical knowledge may become handy for interns. For instance, virtual construction site games have been developed to teach occupational safety effectively (Greuter et al., 2012) whereas landscape design education (Örnek, 2013), surgical field (Baby et al., 2016), and construction simulations could be added to the list. Well-structured virtual games can be used

CASE STUDIES OF INCORPORATING BIM MODELS IN THE DIGITAL GAME ENVIRONMENT

with sufficient competence to teach architectural education and architectural building knowledge in a video game environment. One way of achieving this is to utilize BIM tools with a game engine. Indeed, exemplary of such workflow is shown by several case studies in the literature that are well structured and serve different purposes (Rüppel and Schatz, 2011; Edwards et al., 2015; Liu et al., 2014). In detail, Bill et al.(2014) utilized a Revit BIM model in conjunction with the Unity3D game engine. Similarly, the study of Kumar et al.(2011) retrieved an FBX format 3D model from a BIM model for use in the Unity3D game engine. Furthermore, Yan and Liu (2007) conducted a study on BIM technologies and digital game collaboration to contribute to the development of design education. Merschbrock et al. (2016) made use of BIM technologies for creating virtual hospital environments in serious game development. Distinctly, Garcia-Fernandez and Medeiros (2019) assert that simulation video games are fitted for conveying cultural heritage (CH) values and forms the basis for supporting edutainment in a digitalizing community.

2.1. UNDERSTANDING DIGITAL GAMES AND BIM TOOLS

Advances in BIM have picked a substantial pace in recent years (Smith, 2014) which has acted as a driving force for the digitalization of the construction sector to the extent that the value of BIM tools and relevant outputs have been recognized by the project management services (Bryde et al., 2013). Addedly, digitalization efforts are not limited to the advances in BIM technology. Adopting virtual environments in the construction applications and the construction worker training programs is gradually gaining sectoral interest (Guo et al., 2012; Dawood et al., 2014). Furthermore, digital games and simulations can serve as a bridge between theoretical and practical knowledge (Dib and Adamo-Villani, 2014). Relatedly, from an educator standpoint, Castronovo et al. (2014) acknowledge the potential of using digital technology in design and construction as students show great excel in acquiring applied knowledge that has been traditionally available only thru practical experience. Moreover, Wu and Kaushik (2015) mention the pedagogical aspect of undertaking BIM and the game engine towards learning and professional training. Besides, teaching construction technology on the construction site is not feasible due to reasons such as the number of classroom attendants and construction site safety measures. Therefore, computer-generated serious games may be dialed in as potential solutions (Forsythe, 2013).

Indeed, contemporary approaches and application domains in construction education have become more diversified through digital game-based learning methods. Simulation-based serious games contribute to the teaching

activities via presenting the phases on the components of the building, site construction progress, and related project management issues to the users virtually. In this context, Pariafsai (2016) emphasizes the importance of training with virtual simulation games in the “construction education”. Differently, as-built BIM models of historic buildings are also used for simulation, monitoring, and digital heritage database creation purposes. Further, virtual heritage environments stand out from other games by conveying an exclusive story content (Champion, 2003) established on a multi-layered historical background. Meanwhile, the accuracy of the digital models is very crucial in representing the real-life condition of the simulated historic building (Bille et al., 2014). In the creation of virtual heritage environments, entering data pertinent to geometric components of historical buildings, detailed construction information, material properties, maintenance status, and measurement accuracy is critical in achieving detailed results. Surprisingly, intangible cultural heritage is as equally suited for processing in the digital game environment as the tangible cultural heritage. For instance, Dagnino et al. (2017) performed virtual simulations using the Unity3D game engine and C# scripts to teach intangible cultural heritage in a specific area.

During the data collection phase, the present condition of any object/structure can be largely transferred to BIM tools by taking advantage of innovative technologies such as point cloud, laser scanning, photogrammetry, etc. Particularly, laser scans provide uttermost precision in creating point cloud references for making 3D models. Such workflow was adopted in the work of Banfi et al. (2019) where the model of a historic building was created from point cloud data in a BIM platform and thereafter imported to Unreal Engine 4 to create a virtual reality environment. Addedly, the study of Gaugne et al. (2019) is another good example of how point cloud and virtual reality technologies could aid in the visualization and presentation efforts of archaeological sites.

3. Case Study: A Historic Khan Project & Contemporary Building for Student Centre

Two separate buildings with distinct characteristics were explored in the scope of this study. The first case was about a historic building called Çardak Khan located in Denizli, Turkey. This 13th-century rectangular building hosts a courtyard and the main building with small-openings (Parla and Altinsapan, 2008). The second case was about a contemporary building functioning as a student center. In this study, the following software packages were utilized: Autodesk AutoCAD 2021, Autodesk Revit 2020, SketchUp 2019, Navisworks Manage 2020, Autodesk 3DSMax. Furthermore, MindMup (2019) and Trelby were used to write game script respec-

CASE STUDIES OF INCORPORATING BIM MODELS IN THE DIGITAL GAME ENVIRONMENT

tively. In script analysis section, the Voyant Tools (n.d.) which is online digital tool was used to analyze game scripts in detail.

In the first case study, mediums such as total station and laser distance meter were used in the survey of the interior spaces and courtyard of the historic Khan (Yönder et al., 2017). The methodology for this specific case comprised three distinctive parts in the following order: obtaining survey data, making 2D drawings (plan, section, and elevation drawings) and creating competent digital models, and later building a game scenario/environment [Figure 1].

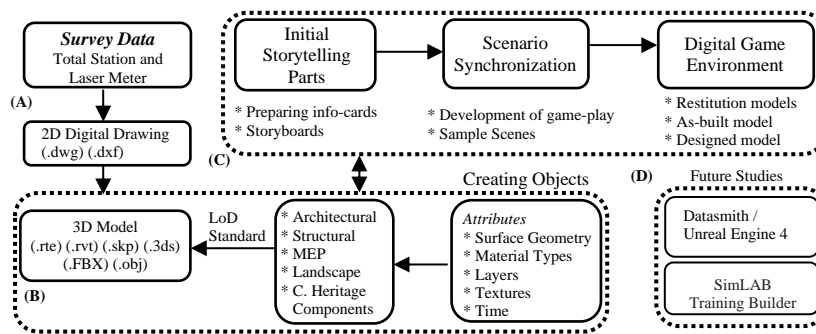

Figure 1. Workflow for gamification process for BIM-based models in this study

In the second case study, the methodology comprised three distinctive parts in the following order: creating an architectural program for a student center building, creating a comprehensive BIM model with architectural, mechanical, and static components, and later building a game scenario/environment [Figure 1]. At this point, determining the model's level of detail (LoDs) was crucial for both cases. It was not the building components of the student center which were rational and identifiable but rather the historic building components and courtyard ruins which were made with outdated construction techniques and unique physical shapes posed plenty of challenges in the level of detail determination. In addition, the elements that make up the model groups need to be classified according to their attributes and placed in dissimilar subgroups to easily manage them in the digital environment.

In line with these modeling guidelines, the thick walls, water channels of the bath, kitchen, and basin, skylight openings on the roof, and the long span vaults of the building in Case 1 were modeled and recorded. Then, based on the restitution research, 3D models were developed for the courtyard spaces and interior use (Yönder et al., 2017) [Figure 2]. One-to-one extraction of the surface materials was not possible with the available tools for this study therefore sufficient competence for surface texturing has not been met.

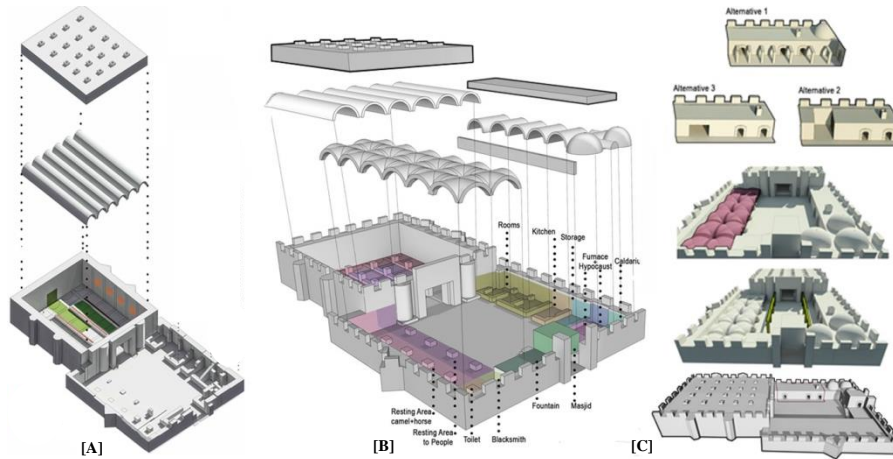

Figure 2. As-built model and restitution phases' models of the historic Khan
(Source: Yönder et al., 2017)

In Case 2, the building was planned as a two-story building distinguished with modern architectural features [Figure 3]. Building components were modeled in the Revit environment by using generic Revit components. The final model was later exported as NWC file format to Autodesk Navisworks 2020 environment in order to create a 4D construction simulation of the building. 4D simulations of the building were created according to the proposed construction schedules such as micro and macro. Besides, insights gained from 4D analysis gave initial ideas for creating storyboards and scene sequences.

Aside from obtaining detailed models, writing game scripts and designing in-game sequences were the other milestones in this study. Foremost, the sequences that relay the educational information in the context of the game should adhere to the original script. Hence storytelling is the focal point of this research and it is of primary significance to convey impeccable information to the users. Consequently, in Case 1, virtual cards that will convey the spatial and historical information of the historic Caravanserai building were placed in four pre-designated locations. Two of those scenes were located in the courtyard and the rest in the interior of the Caravanserai [Figure 4]. Camera angles for those pre-designated locations have been chosen for the best viewing experience. The same implementation process was carried out for the restitution model as well.

CASE STUDIES OF INCORPORATING BIM MODELS IN THE DIGITAL GAME ENVIRONMENT

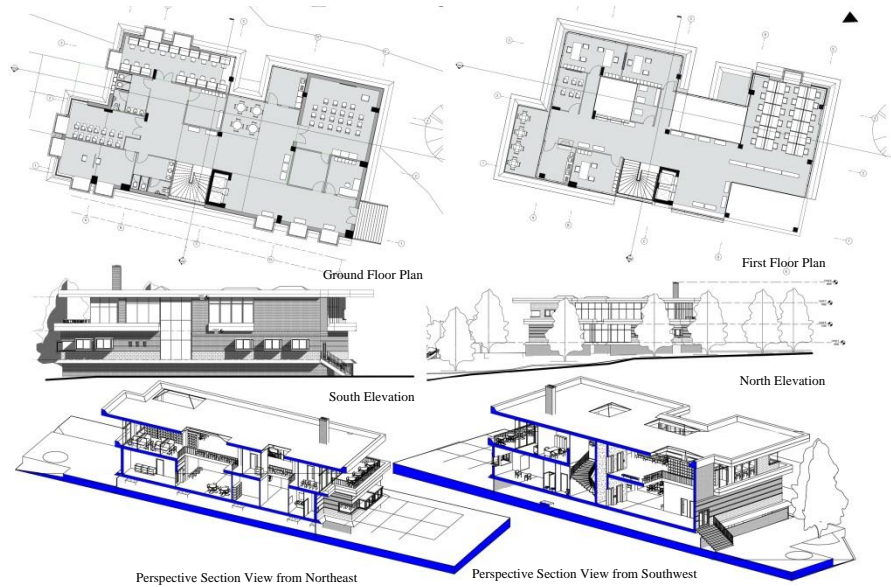

Figure 3. Contemporary Student Center Building modeled with BIM Tools

In Case 2, two indoor and four outdoor locations were determined for the virtual cards [Figure 5]. These cards disclose detailed information about the building (spaces, construction technique, and construction schedule, etc.). The draft scripts were prepared in order to streamline sequences and general operations [Figure 4 and Figure 5]. According to the script, while wondering spaces from the basement to the second floor, the user will select and read the information cards related to the building and earn points. During the preparation of case scripts, the flow of the game over the role and the transition between virtual spaces were designed.

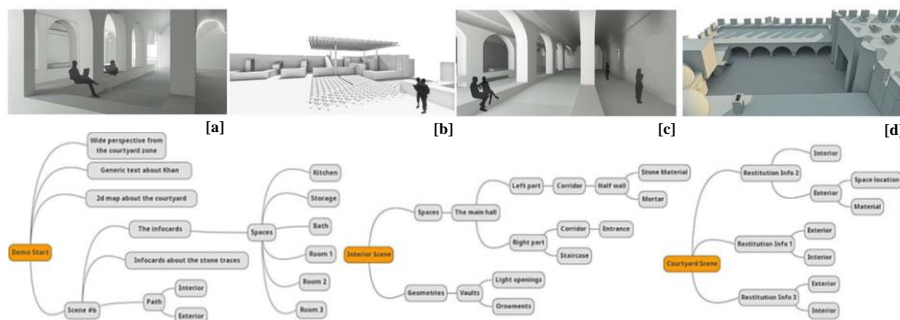

Figure 4. Pre-determined locations for the scenes in the historic Khan building (Upper) and the partial view of the concept mapping for the script design

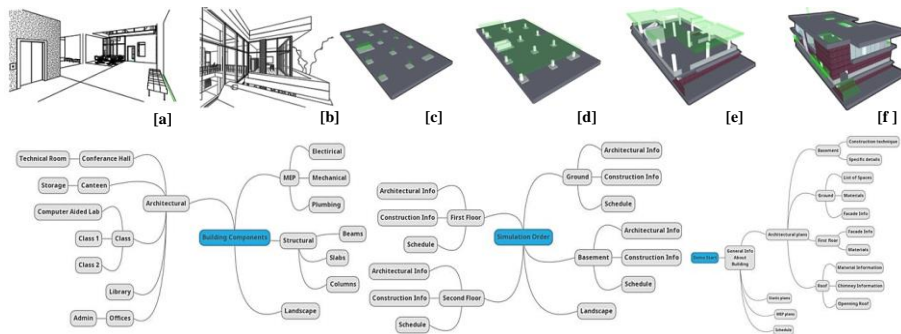

Figure 5. Pre-determined locations for the scenes in the student center building (Upper) and the partial view of the concept mapping for the script design

Transferring the created models to the game engine is another momentous work package because it is critical to submit the geometry completely and transfer the surface materials without error. The methods of transferring a 3D/BIM model to a real-time environment may vary (Boeykens, 2011).

4. Results and Discussion

The relevant literature avows that the simulations and interactive environments in educational digital games support users technically and cognitively. In this respect, this study aims to generate digital architectural educational game environments and solicit their advantages in architectural education in dissimilar cases. One of the main concerns in those cases is to ensure that the virtual environments are created in harmony with the original scenarios. For this reason, using storyboards has been an indispensable tool for game development. However, various difficulties were encountered during both the geometric modeling stages and the scenario writing. These problems encountered in the process and possible solutions will be articulated comparatively. Although procedures for creating the game environment and the script in both cases showed similarity, a disparity in its implementation was noted. Naturally, the first disparity arises from the number of spaces and spatial features [Figure 6]. While the contemporary student center building comprised ten independent sections, the restitution model of the Khan building comprised thirteen sections, and the consecutive pre-restoration version consisted of eight sections. Comparatively, the creation process of the restitution model took the longest time and the number of spaces modeled was the highest [Figure 6]. The second disparity is due to the model creation and story building time as the caravanserai building offered more details and required an additional (pre-restoration) model. On the other hand, the contemporary student center project was designed with the readily available

second case. Ultimately, future study will encompass establishing interaction capabilities and physics, advanced interface design within the game engine in order to pave the way for VR interaction. Creating VR-based scenes is foreseen to be especially valuable in presenting Çardak Han. Yet, it is also intended to add more historic scenarios to the game to increase its allure-ment.

Acknowledgements

I want to thank Prof. Dr. Mine Turan (Project Leader at Çardak Khan Restoration Project) for her endless support. Besides, I would like to express my gratitude to the project team.

References

- ALVAREZ, J. & DJAOUTI, D. 2011. An introduction to Serious game Definitions and concepts. *Serious Games & Simulation for Risks Management*, 11, 11-15.
- AZHAR, S., KHALFAN, M. & MAQSOOD, T. 2015. Building information modelling (BIM): now and beyond. *Construction Economics and Building*, [online] 12(4), pp.15-28. Available at: <https://epress.lib.uts.edu.au/journals/index.php/AJCEB/article/view/3032>.
- BABY, B., SRIVASTAV, V., SINGH, R., SURI, A. & BANERJEE, S. Serious games: An overview of the game designing factors and their application in surgical skills training. *2016 3rd International Conference on Computing for Sustainable Global Development (INDIACom)*, 2016. IEEE, 2564-2569.
- BANFI, F., BRUMANA, R. & STANGA, C. 2019. Extended reality and informative models for the architectural heritage: from scan-to-BIM process to virtual and augmented reality. *Virtual Archaeology Review*, 10(21), p.14.
- BILLE, R., SMITH, S. P., MAUND, K. & BREWER, G. 2014. Exploring building information modelling (BIM) to game engine conversion. Working Paper Series.
- BOEYKENS, S. 2011. Using 3D Design software, BIM and game engines for architectural historical reconstruction. *Designing Together-CAADfutures 2011*, 493-509.
- BRYDE, D., BROQUETAS, M. & VOLM, J.M. 2013. The project benefits of Building Information Modelling (BIM). *International Journal of Project Management*, [online] 31(7), pp.971–980. Available at: <https://www.sciencedirect.com/science/article/pii/S0263786312001779>.
- CASTRONOVO, F., NIKOLIC, D., ZAPPE, S. E., LEICHT, R. M. & MESSNER, J. I. Enhancement of learning objectives in construction engineering education: a step toward simulation assessment. Construction Research Congress 2014: Construction in a Global Network, 2014. 339-348.
- DAGNINO, F. M., POZZI, F., COZZANI, G. & BERNAVA, L. Using Serious Games for Intangible Cultural Heritage (ICH) Education: A Journey into the Canto a Tenore Singing Style. *VISIGRAPP (5: VISAPP)*, 2017. 429-435.
- DAWOOD, N., MILLER, G., PATACAS, J. M. D. L. & KASSEM, M. 2014. Construction health and safety training: the utilisation of 4D enabled serious games. *Journal of Information Technology in Construction*, 19, 326-335.

CASE STUDIES OF INCORPORATING BIM MODELS IN THE DIGITAL GAME ENVIRONMENT

- DIB, H. & ADAMO-VILLANI, N. 2014. Serious sustainability challenge game to promote teaching and learning of building sustainability. *Journal of Computing in Civil Engineering*, 28(5), A4014007.
- DINIS, F. M., GUIMARÃES, A. S., CARVALHO, B. R. & MARTINS, J. P. P. Virtual and augmented reality game-based applications to civil engineering education. 2017 IEEE Global Engineering Education Conference (EDUCON), 2017. IEEE, 1683-1688.
- DJAOUTI, D., ALVAREZ, J., JESSEL, J.-P. & RAMPNOUX, O. 2011. Origins of serious games. *Serious games and edutainment applications*. Springer.
- EDWARDS, G., LI, H. & WANG, B. 2015. BIM based collaborative and interactive design process using computer game engine for general end-users. *Visualization in Engineering*, 3(1), 1-17.
- EGENFELDT-NIELSEN, S. 2010. The challenges to diffusion of educational computer games. *Leading Issues in Games Based Learning*, 141.
- FISCH, S. M. Making educational computer games" educational". Proceedings of the 2005 conference on Interaction design and children, 2005. 56-61.
- FORSYTHE, P. Using Serious Games and Virtual Simulations in Construction Technology Education. CIB World Building Congress, 2013. Queensland University of Technology.
- GARCIA-FERNANDEZ, J. & MEDEIROS, L. 2019. Cultural Heritage and Communication through Simulation Videogames—A Validation of Minecraft. *Heritage*, 2, 2262-2274.
- GAUGNE, R., PETIT, Q., BARREAU, J.-B. & GOURANTON, V. Interactive and Immersive Tools for Point Clouds in Archaeology. ICAT-EGVE 2019-International Conference on Artificial Reality and Telexistence-Eurographics Symposium on Virtual Environments, 2019. 1-8.
- GREUTER, S., TEPE, S., PETERSON, J. F., BOUKAMP, F., D'AMAZING, K., QUIGLEY, K., VAN DER WAERDEN, R., HARRIS, T., GOSCHNICK, T. & WAKEFIELD, R. Designing a game for occupational health and safety in the construction industry. Proceedings of The 8th Australasian Conference on Interactive Entertainment: Playing the System, 2012. 1-8.
- GUO, H., LI, H., CHAN, G. & SKITMORE, M. 2012. Using game technologies to improve the safety of construction plant operations. *Accident Analysis & Prevention*, 48, 204-213.
- KUBBA, S. 2012. *Handbook of green building design and construction: LEED, BREEAM, and Green Globes*, Butterworth-Heinemann.
- KUMAR, S., HEDRICK, M., WIACEK, C. & MESSNER, J. I. 2011. Developing an experienced-based design review application for healthcare facilities using a 3D game engine. *Journal of Information Technology in Construction (ITcon)*, 16, 85-104.
- LAAMARTI, F., EID, M. & EL SADDIK, A. 2014. An Overview of Serious Games. *International Journal of Computer Games Technology*, [online] 2014, pp.1-15. Available at: <https://www.hindawi.com/journals/ijcgt/2014/358152/#B69> [Accessed 24 Apr. 2019].
- LIU, R., DU, J. & ISSA, R. R. 2014. Human library for emergency evacuation in BIM-based serious game environment. *Computing in Civil and Building Engineering (2014)*.
- MACHER, H., LANDES, T. & GRUSSENMEYER, P. 2015. POINT CLOUDS SEGMENTATION AS BASE FOR AS-BUILT BIM CREATION. *ISPRS Annals of Photogrammetry, Remote Sensing & Spatial Information Sciences*, 2.
- MARLOW, C. M. Games and learning in Landscape Architecture. 10th International Conference on Information Technologies in Landscape Architecture, 2009.
- MERSCHBROCK, C., LASSEN, A. K., TOLLNES, T. & MUNKVOLD, B. E. 2016. Serious games as a virtual training ground for relocation to a new healthcare facility. *Facilities*, 34(13/14), pp.788-808.

V. YÖNDER

- MindMup (2019). *MindMup*. [online] MindMup. Available at: <https://www.mindmup.com/> [Accessed 1 Jan. 2021].
- MININEL, S., VATTA, F., GAION, S., UKOVICH, W. & FANTI, M. P. A customizable game engine for mobile game-based learning. 2009 IEEE International Conference on Systems, Man and Cybernetics, 2009. IEEE, 2445-2450.
- MURPHY, M., CORNS, A., CAHILL, J., ELIASHVILI, K., CHENAU, A., PYBUS, C., SHAW, R., DEVLIN, G., DEEVY, A. & TRUONG-HONG, L. 2017. DEVELOPING HISTORIC BUILDING INFORMATION MODELLING GUIDELINES AND PROCEDURES FOR ARCHITECTURAL HERITAGE IN IRELAND. *ISPRS - International Archives of the Photogrammetry, Remote Sensing and Spatial Information Sciences*, XLII-2/W5, pp.539–546.
- ÖRNEK, M. A. 2013. Exploring the potential uses of computer games in landscape architecture education. *A/ Z ITU Journal of the Faculty of Architecture*, 10, pp.161-177.
- PARIAFSAI, F. 2016. Effectiveness of a virtual project-based simulation game in construction education. *International Journal of Scientific Research in Science, Engineering and Technology (IJSRSET)*, 2(5), 377-393.
- PARLA, C. & ALTINSAPAN, E. 2008. Atabek Ayaz ve Figürlü Bezemeleriyle Denizli Çardak Han. *Erdem*, 195-216.
- RÜPPEL, U. & SCHATZ, K. 2011. Designing a BIM-based serious game for fire safety evacuation simulations. *Advanced Engineering Informatics*, [online] 25(4), pp.600–611. Available at: <https://www.sciencedirect.com/science/article/pii/S1474034611000589>.
- SIMKOVA, M. 2014. Using of computer games in supporting education. *Procedia-Social and Behavioral Sciences*, 141, 1224-1227.
- SMITH, P. 2014. BIM implementation—global strategies. *Procedia Engineering*, 85, 482-492.
- SQUIRE, K. D. 2008. Video game-based learning: An emerging paradigm for instruction. *Performance Improvement Quarterly*, 21, 7-36.
- Trelby.org. (2020). *Home*. [online] Available at: <https://www.trelby.org/> [Accessed 10 Aug. 2020].
- VOCATURO, E., ZUMPARO, E., CAROPRESE, L., PAGLIUSO, S. M. & LAPPANO, D. Educational Games for Cultural Heritage. VIPERC@ IRCDL, 2019. 95-106.
- voyant-tools.org. (n.d.). *Voyant Tools*. [online] Available at: <https://voyant-tools.org/>. [Accessed 10 Dec. 2020].
- WU, W. & KAUSHIK, I. 2015. Design for sustainable aging: improving design communication through building information modeling and game engine integration. *Procedia engineering*, 118, 926-933.
- YAN, W. & LIU, G. 2007. BIMGame: Integrating building information modeling and games to enhance sustainable design and education.
- YAN, W., CULP, C. & GRAF, R. 2011. Integrating BIM and gaming for real-time interactive architectural visualization. *Automation in Construction*, 20(4), 446-458.
- YÖNDER, V. M., BAYRAM, A., NALÇA, C., KEKE, B., ÖZEL, E., ÖZDEMİR, E., YÖNETKEN, E., EKEN, E., DURMUŞLAR, F., ŞENER, İ., ERGİN, M., BİRGİN, Ö., 2017, Restoration Project of Çardak Khan Denizli, Design in Architectural Restoration II, 2016-2017 Spring Semester, Supervisors: M. Hamamcıoğlu Turan and K. Çelik, Izmir Institute of Technology (IZTECH), Department of Architectural Restoration, Izmir.

MATERIAL-BASED PARAMETRIC FORM FINDING

Learning Parametric Design through Computational Making

SHERIF ABDELMOHSEN, PASSAINT MASSOUD

American University in Cairo

Email address: sherifmorad@aucegypt.edu

L'Universite Francaise d'Egypte

Email address: passeint.massoud@ufe.edu.eg

Abstract. Most approaches developed to teach parametric design principles in architectural education have focused on universal strategies that often result in the fixation of students towards perceiving parametric design as standard blindly followed scripts and procedures, thus defying the purpose of the bottom-up framework of form finding. Material-based computation has been recently introduced in computational design, where parameters and rules related to material properties are integrated into algorithmic thinking. In this paper, we discuss the process and outcomes of a computational design course focused on the interplay between the physical and the digital. Two phases of physical/digital exploration are discussed: (1) physical exploration with different materials and fabrication techniques to arrive at the design logic of a prototype panel module, and (2) deducing and developing an understanding of rules and parameters, based on the interplay of materials, and deriving strategies for pattern propagation of the panel on a façade composition using variation and complexity. The process and outcomes confirmed the initial hypothesis, where the more explicit the material exploration and identification of physical rules and relationships, the more nuanced the parametrically driven process, where students expressed a clear goal oriented generative logic, in addition to utilizing parametric design to inform form finding as a bottom-up approach.

Keywords: *Material-based computation, parametric design, form finding, computational making, digital materiality, algorithmic thinking.*

ملخص. استندت معظم الأساليب التي تم تطويرها لتدريس مبادئ التصميم البارامتري في التعليم المعماري إلى استراتيجيات عامة غالباً ما تؤدي إلى ترسيخ فكر الطلاب نحو إدراك

التصميم البارامترى باعتباره مجرد مجموعة من النصوص والإجراءات الاعتيادية الواجب اتباعها بشكل أعمى، مما يتعارض مع مفهوم إطار العمل التصاعدي لإيجاد الشكل. وقد تم مؤخرا إدخال ما يعرف بالحوسبة القائمة على المادة في عملية التصميم الحوسبي، حيث يتم دمج المتغيرات والقواعد المتعلقة بخصائص المواد في التفكير الحوسبي. نناقش في هذه الورقة البحثية العمليات والنتائج الخاصة بمادة دراسية متخصصة في التصميم الحوسبي تركز على التفاعل بين المادية والرقمية. تم مناقشة مرحلتين من الاستكشاف المادي الرقمي: (١) الاستكشاف المادي باستخدام مواد وتقنيات تصنيع مختلفة للوصول إلى تصميم نموذج أولى لوحدة، و (٢) استنتاج وتطوير قواعد ومعايير بناء على تفاعل المواد واشتقاق استراتيجيات لأنماط الوحدة في إطار تكوين على واجهة مبنى باستخدام أطر متباينة التعقيد. وقد أكدت العمليات والنتائج النهائية فرضية البحث، فكلما كان استكشاف المواد وتحديد القواعد والعلاقات المادية أكثر وضوحاً كلما اتضحت العملية المدفوعة بالتصميم البارامترى، حيث عبر الطلاب عن منطق توليدي واضح الهدف، بالإضافة إلى استخدام التصميم البارامترى لإيجاد الشكل من خلال منهج تصاعدي.

الكلمات المفتاحية: الحوسبة القائمة على المادة، التصميم البارامترى، إيجاد الشكل، التصنيع الحوسبي، المادية الرقمية، التفكير الحوسبي.

1. Introduction: Materiality, Parametric Form Finding, and Learning

Algorithmic thinking is generally perceived as comprising rules, steps and procedures that aim at producing digital forms through computational scripts (Oxman, 2017). The primary purpose of algorithmic thinking in learning settings, especially in architectural education, involves encouraging students to test, explore, and integrate multiple variables and constraints with the aim of identifying optimal solutions (Megahed, 2013). Most approaches and methods developed to teach parametric design within an algorithmic thinking framework in architectural education however have tended to focus on universal strategies and techniques that often defy the purpose of the bottom up approach implied by parametric form finding methods.

Architecture students are increasingly exposed to concepts of parametric modeling, generative design, and digital fabrication during their undergraduate education. Despite the availability of resources, the risk of being immersed into complicated software logistics at the expense of creative exploration, algorithmic thinking, and methodical form finding presents a pedagogical challenge within computational design curricula. With the abundance of ready-made scripts, preset procedures, and custom plugins in software tools like Grasshopper or Dynamo, student learning is often masked by a tendency to develop preset forms that could potentially lack the critical dimension of creative design exploration and the expanded solution space afforded by such a rich parametrically driven approach.

Concepts of “digital materiality”, “material-based computation”, and using physical modeling for form finding purposes have recently been integrated into computational design, where parameters, rules, constraints, and relations pertaining to material behavior and properties are captured with the purpose of informing the algorithmic and computational design thinking process (Gramazio and Kohler, 2008; Kolarevic and Klinger, 2008; Menges, 2016;

MATERIAL-BASED PARAMETRIC FORM FINDING: LEARNING PARAMETRIC DESIGN THROUGH COMPUTATIONAL MAKING

Oxman, 2010; Yazici, 2019; Yazici and Tanacan, 2020). Digital materiality (Gramazio and Kohler, 2008) was incorporated in the architectural realm with specific focus on the coupling between the digital and the material, more precisely on the combined understanding of structure, material, and form in an experimental framework of form generation and fabrication (Menges, 2016; Oxman, 2012). “Computational making” has also been introduced as a catalyst in understanding and augmenting the notion and potential of making in computation and creative design exploration activities (Knight and Vardouli, 2015).

With the increasing impact of the new generation of digital materiality and tectonics in architecture, the role of materials and making in design is being continuously redefined as a catalyst and a key driver in design activity and exploration. Parameters, rules, constraints, and relations involving a variety of material properties are becoming more integrated into computational design both in terms of modeling and design thinking.

With origins in the principles and practices of “learning by doing” (Dewey, 1997) and “learning by making” by Seymour Papert, pedagogies related to making and craft have also been introduced in architectural education (Karppinen et al. 2017). Engagement and active participation are primary tenets of these approaches, where the learner is more of an active participant than a passive knowledge recipient (Kolb, 1984). As a by-product in such an engaging approach that builds on principles of constructivist pedagogy, learners interact with materials, tools, equipment, and machines in a process of making, and their learning experience is enriched through craft-based and hands-on production rather than focusing merely on a final outcome or product (Moholy-Nagy 2005; El-Zanfaly 2015; Ozkar 2007).

In this paper, we address the main question: how can making and the physical interplay of materials inform the process of parametric form finding in an educational setup? We are more interested in how material-based approaches and hands-on experience with materiality cater for a better understanding of the main principles of parametric design and augment student learning outcomes and skills in relation to algorithmic thinking.

2. Approach

We discuss the process and outcomes of a computational design course focused on the interplay between the physical and the digital. The course comprised two phases of physical/digital exploration: (1) physical exploration with different materials and fabrication techniques, and (2) deducing and developing an understanding of rules, parameters, relationships and constraints, based on the interplay of materials and applied techniques.

The main hypothesis in this computational design course is that the more explicit the material exploration, understanding and testing, the richer the

learning process of parametric design principles and the more nuanced and grounded the parametrically driven process. Through making and hands-on identification of physical rules and relations, it is presumed that students would develop a clear, structured, and explicit goal oriented generative logic within a form finding framework. Such a material-based approach is expected to inform the parametric form finding process through the iterative physical/digital interplay, as illustrated in Figure 1.

2.1 PHASE 1: THE BLANK FAÇADE CANVAS

In this phase, students were encouraged to explore the dimensions of materiality and tectonics through their experimentations. They were asked to manually fabricate a prototype panel that would fit in a volume of 30cmX30cmX15cm, as a physical box or hypothetical volume, using one of two specific fabrication techniques; casting or fabric forming, using an easily deformable material such as gypsum. The students were encouraged to focus their inquiry during material exploration on the following questions: What can be learned from the physical interplay of materials? What different techniques can be implemented to experiment with materials? And how can these techniques be utilized to inform design innovation?

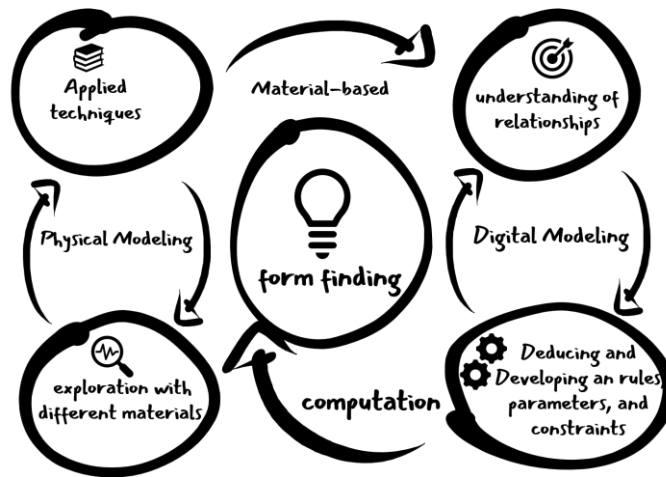

Figure 1. Proposed framework for learning parametric design based on material-based computational making within a form finding process.

With those questions in mind, the students were asked to research different materials, techniques, and examples, and develop accordingly a physical model of the required volume using either casting or fabric forming. They were intentionally asked to conduct this experiment manually without the aid

MATERIAL-BASED PARAMETRIC FORM FINDING: LEARNING PARAMETRIC DESIGN THROUGH COMPUTATIONAL MAKING

of software so that they can learn from the hands-on experience and the physical manipulation of different materials and geometries.

Through this physical interplay of materials, the students were encouraged to explore the breadth of possibilities afforded by material behavior and properties by observing properties of texture, strength, rigidity, solid and void percentages and relations, pre-failure thresholds, and possibilities of adding multiple layers of similar or different materials. In addition to the physical model, the students were asked to present a detailed record of the fabrication process in the form of time-based sequences and sketches demonstrating the thought process.

In order to have controlled but rather unlimited possibilities, casting and fabric forming techniques were implemented for the purpose of the material experimentation. This was done to observe the formation possibilities in addition to the material behavior and limitations in response to different casted surface topologies. For example, figure 2 illustrates exploratory work conducted by one of the students, where the student used primary formwork (lycra) and secondary formwork (wooden sticks) in conjunction to guide the configuration of the final casted geometry using gypsum as a casted material. Different allocations, dimensions and types of the secondary formwork were used to come up with different geometric configurations.



Figure 2. Student exploratory work to understand the behavior and interplay of different materials and identify affecting parameters. [Photo credit: Sophie Rami]

Figure 3 also shows an example of different combinations of formwork, where the student used a foamboard box with creased cloth laid in its base, in addition to using rods, cups and bowls of different sizes to act as a subtractive technique on the final resulting form. This allowed for exploring different creased and textured panels with the opportunity to create voids and perforations of different sizes in different locations.

By the end of this phase, the students were asked to reflect on lessons learned from the physical interplay of materials, as opposed to a typical digital exercise to produce similar forms. They were also asked to reflect on the specific techniques used and learned throughout the experimentation and casting or fabric forming process. More specifically, the students were asked to enlist the specific parameters, rules, relationships, and constraints governing the generative logic of their designed prototypes, using analytical diagrams, sketches, images, and sequences from their process.



Figure 3. Example student setup of the formwork for their material exploration phase. [Photo credit: Yasmin Hazem]

The premise was to allow students to begin identifying specific low-level input parameters that are presumed to affect the resulting output parameters. As opposed to high-level factors such as surface geometry, mixture, and formwork shape, the students would have to identify more specifically input parameters such as the coordinates of the support points of the bounding volume or fixation points of the fabric mesh held in tension, the height, length and width of wooden sticks used as secondary formwork, or the radius of the rod used to create perforations within the panel. Throughout their explorations, the students would work on physically altering these parameters and identify the effect on the resulting form, and more specifically output parameters such as surface thickness, surface texture, density, and solid/void percentage within the panel configuration. Figure 4 illustrates some of the student reflections and derivations of input parameters that define the different possibilities of their designed panel configurations.

MATERIAL-BASED PARAMETRIC FORM FINDING: LEARNING PARAMETRIC DESIGN THROUGH COMPUTATIONAL MAKING

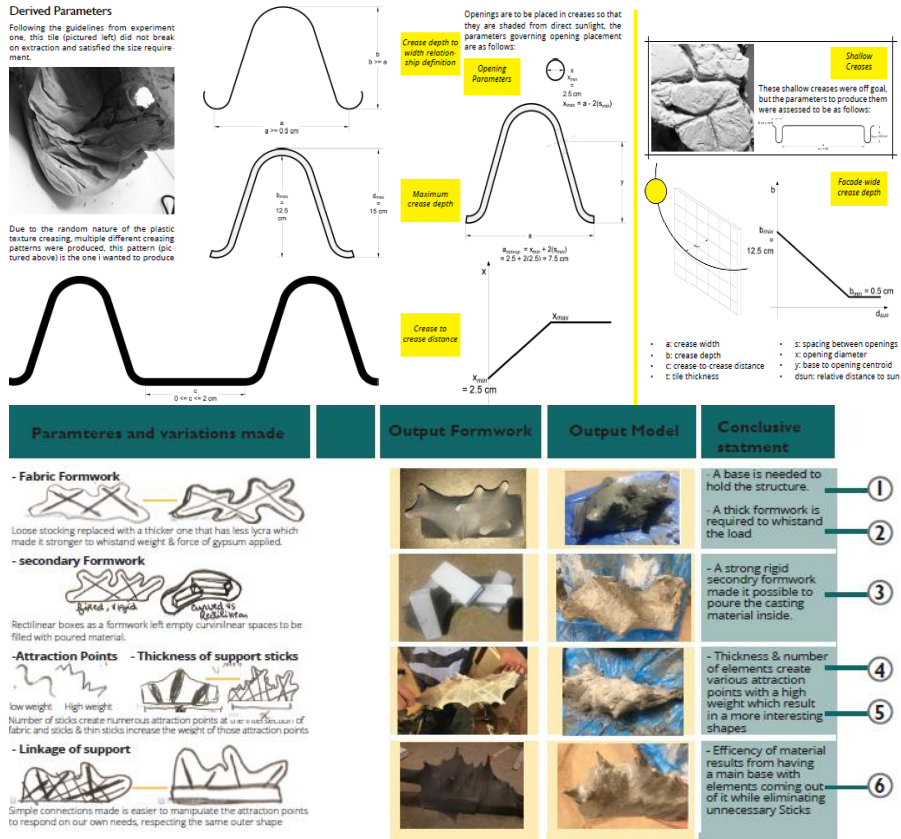

Figure 4. Student reflections of the derived parameters from the material exploration phase. [Photo credit: Maram Zeitoun, Sophie Rami]

2.2 PHASE 2: THE PARAMETRIC FACELIFT

The objective of the second phase was to design a parametrically driven full-scale façade skin for an existing building using a passive approach. A specific office building in New Cairo, towards the East of Cairo, Egypt, was selected. The main façade of the building was in a South/Southwest/West orientation a curved façade) with full glazing. Students were required to devise an appropriate envelope that provides adequate shading and sun protection for this façade in such a hot arid climate.

In doing so, the students were provided with some basic guidelines, constraints, and allowed changes to follow during their façade design process. This included defining a maximum protrusion for the double skin façade component, creating interesting and dynamic spatial settings within

the double skin façade, assuming modifications (recesses or protrusions) to the existing external glazed wall and slab edge profile configurations, specifying mechanisms for façade configuration and operation (static or dynamic configurations), and addressing specific strategies for propagation of the designed panels across the overall façade composition.

The students were asked to identify from the first phase the relationships, parameters, constraints, and rules that could be exploited for creative design exploration in the parametric modeling phase using form-finding as a bottom-up approach. They were required to capitalize on ideas captured from the material exploration phase and develop conceptual approaches based on the derived parameters and rules to define extensive iterations for multiple design alternatives. The idea of having double facade opened the opportunity to the students to have an adaptive skin concept using the generative performative design approach in this phase. A clear and explicit strategy for pattern propagation of the panel design module was required based on performance variables and criteria, including possible combinations or iterations of strategies such as repetition, tiling, weaving, branching, force fields, recursion, subdivision, and packing (Figure 5).

The implicit objective of this strategy was to generate variation and complexity rather than mere repetition of the initial panel module. Students were encouraged to account for daylighting, ventilation, visibility, spatial, functional, and/or aesthetic considerations that regulate their adaptive building skin façade designs using the logic of pattern propagation.

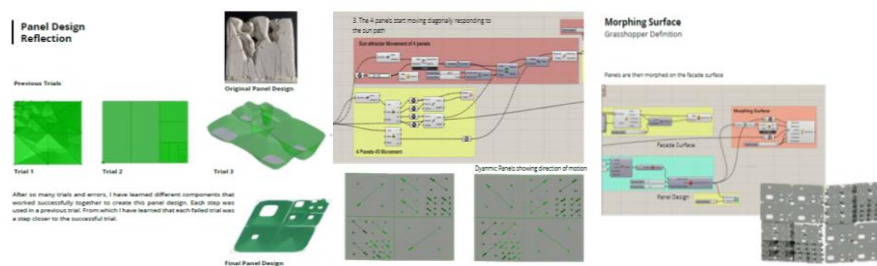

Figure 5. Implementing panel propagation strategies in Grasshopper. [Photo credit: Yasmin Hazem]

3. Observations and Discussion

The student outcomes and results varied in terms of techniques, formwork, casted materials, deduced parameters, and geometries, in addition to design patterns, strategies and exploratory paths. The following two sections

MATERIAL-BASED PARAMETRIC FORM FINDING: LEARNING PARAMETRIC DESIGN THROUGH COMPUTATIONAL MAKING

describe some of the main observations and findings, both in relation to the material exploration phase and the parametric design phase.

3.1 MATERIAL EXPLORATION PHASE

The results of the material exploration phase involved a variety of approaches, processes, and outcomes. Students explored a wide range of possibilities regarding the type of formwork and casted materials. Most of the students used two kinds of formwork: (1) primary formwork and (2) secondary formwork. Primary formwork involved the main container for the material to be casted or poured, including fabric with flexible boundaries such as lycra, nylon, stockings, cotton, wire mesh, cloth, towels, as well as aluminum foil, foam boards and paper. In some other cases, it included rigid containers such as wooden boxes or frames, plastic or glass cups, boxes and bags, ice cubes, etc. In some cases, students used a combination of both fabric and rigid containers. Students used different types of fixation for their formwork in order to retain and geometrically shape the casted material. These included suspending fabric onto rigid frames from specific points using clippers and hangers, or knitting and sewing fabric components together to pour material from specific locations.

Some students used secondary formwork as an auxiliary technique to fixate or regulate the primary formwork they used. For example, some students used wooden or metal rods, sticks or rings to regulate the geometry of the used fabric formwork. Others used tubes, plastic containers, or other cylindrical pegs to fully mask the formwork and therefore avoid casting in specific locations in order to create voids in the resulting shape geometry. Others used foam or wooden boards to shape the resulting geometry and control the final thickness and depth of the resulting configuration or reshape its surface texture.

In terms of the casted materials, students experimented with mostly gypsum or cement and water. A few experimented with other materials such as hot wax. The challenge with the material primarily involved arriving at the right mixture ratio so that the material dries within a reasonable period of time. This often resulted in consuming considerable time and iterations to test different mixtures and document the appropriate ratios of gypsum to water for example. Once this was established, the students were able to use the same ratios for their subsequent experimentation. Students also used different mechanisms to cast or pour material on the used formwork. Some students dipped the fabric formwork into the material paste. The most common approach however was to pour material vertically into wooden or metal frames or containers, where the final layer of pouring was inverted to become the base of the mold. Other more complex approaches involved

pouring materials into knitted or suspended fabric from one or two points such that the material was contained within the knitted volume. This allowed for more control and regulation of the resulting geometry. Figure 6 shows some examples of panel outcomes.

In terms of approaches, the students exhibited mainly two kinds of directions in this phase. The first direction involved experimenting with different materials with presumably common properties, understanding their similarities and differences, and pushing the limits using different techniques to test the resulting outcome while manipulating parameters such as heights, openings, textures, curved surfaces, etc.

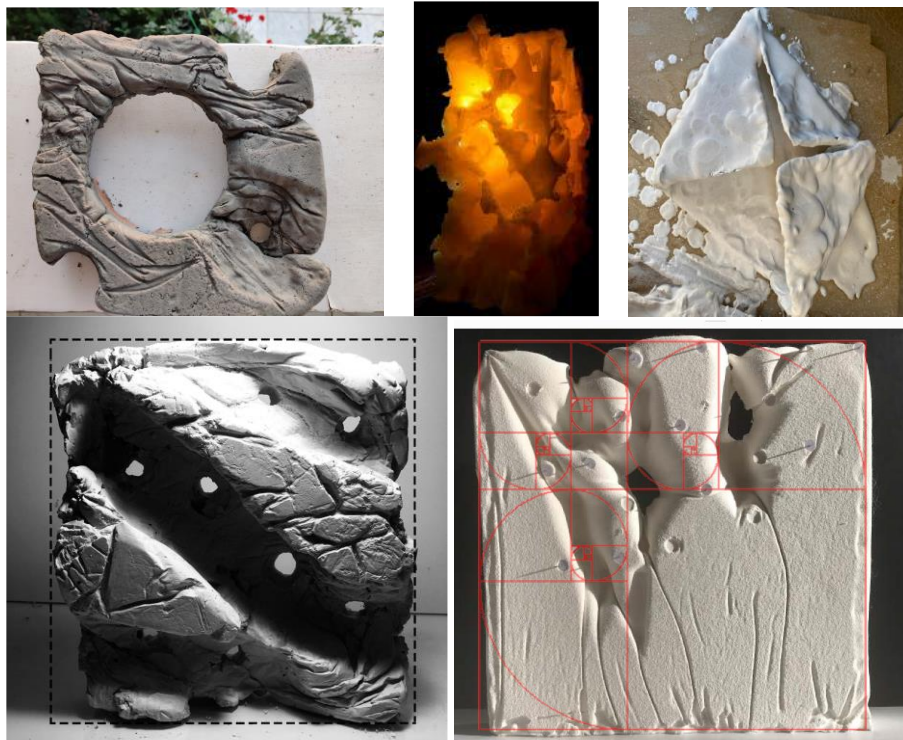

Figure 6. Examples of panel outcomes in Phase 1: The Blank Façade Canvas. [Photo credit; Taghrid Saleh, Mariam Ibrahim, Mayan Abdalla, Maram Zeitoun, and Yasmin Hazem]

The second direction involved a direct interplay from the onset between an easily deformable material and the used formwork, where the students gradually increased or decreased some parameters and deduced rules and relations accordingly. Most of the students experimented with gypsum or cement and water. A couple of students experimented with unique formwork

MATERIAL-BASED PARAMETRIC FORM FINDING: LEARNING PARAMETRIC DESIGN THROUGH COMPUTATIONAL MAKING

and materials (e.g. pouring hot wax in ice formwork or applying heat and fire to cotton as formwork), as shown in Figure 7.

Based on the diversity of approaches and experiment iterations explored by the students, each student identified a set of input parameters, rules, relationships, and constraints that governed their material exploration phase. Input parameters varied and included parameters such as primary formwork dimensions or volume, density of material, secondary formwork dimensions or volume, radius of cylinder as secondary formwork, length/coordinates of wooden/metal sticks as secondary formwork, spacing between formwork elements, etc. Output parameters included parameters such as radius of panel void, panel thickness, panel surface texture, spacing between panel voids, number of panel voids, etc.



Figure 7. Examples of unique experimentation with formwork used for casting materials, including using cotton while applying heat to the casted material, as well as using ice cubes as formwork for casting hot wax. [Photo credit: Reem Shahin, Mariam Ibrahim]

Student approaches varied in the way they defined the relationship between input parameters and output parameters. Some students established direct correlations between a single input parameter and a single output parameter (e.g. “radius of cylinder” as input parameter, and “radius of panel void” as output parameter”). Others established relations between multiple input parameters and a single output parameter (e.g. “height of primary formwork”, “height of secondary formwork”, and “formwork fixation point coordinates” as input parameters, and “panel thickness” as output parameter). In some other cases, a change in a single input parameter affected multiple output parameters (e.g. “primary formwork surface geometry” as input parameter, and “panel texture”, “panel thickness”).

Some of the rules that students identified included defining minimum thresholds for panel thicknesses, minimum spacings between panel voids, and minimum distances between void edges and panel edges. Most of these were derived based on failed experiments, where students passed through several iterations where their panels broke upon drying or during the experiment due to exceeding these thresholds or limitations. After adjusting the mixture, primary and secondary formwork, and the adequate spacings, students were able to identify and list the specific rules that govern the geometries of their designed panels.

Most students expressed their specific appreciation of the way the experiments allowed them to develop structured methods of thinking about explicit parameters and rules governing the design and fabrication of their panels. By documenting all failed and successful attempts, they could (1) expand the design possibilities and solution space for the designed panels, and (2) develop a blueprint for the parametric process without the need to go back and revisit the whole experiment setup and logic. This proved beneficial for the subsequent stage of parametric strategy development and generally for learning more about the parametric tool logistics.

3.2 PARAMETRIC MODELING PHASE

In this phase, students were learning the software (Grasshopper) for the first time in parallel. This was one of the main challenges. The purpose however of the previous phase was to introduce the students to the basic principles of parametric modeling through making and by means of a hands-on exercise, where they could deduce the logic of what a parameter, a rule, or a relation is. Most students started the exercise by defining their general objective for the building facelift and included some environmental, spatial, and functional requirements as a main driver. They then attempted to translate these requirements into specific strategies for the generative exercise of the overall façade composition.

In Grasshopper, the process commenced with a translation of the parameters and rules identified in the material exploration phase into a Grasshopper definition for a single panel. The objective was then to develop a propagation strategy for that panel across the overall façade composition. One of the challenges – and at the same time opportunities – in this exercise was the multi-orientation dimension of the existing façade, where the façade orientation ranged from South to Southwest to West, allowing for possibilities of variation in the nature of the required shading devices in terms of their orientation (more horizontal nature towards the South orientation and more vertical towards the West orientation). A wide opening in the existing building also allowed for the possibility of attracting wind from the Northwest (prevailing wind direction) into the double skin façade component and integrating it within the spatial and functional logic of the

MATERIAL-BASED PARAMETRIC FORM FINDING: LEARNING PARAMETRIC DESIGN THROUGH COMPUTATIONAL MAKING

interior spaces of the existing building. These constraints and opportunities established a need for most students to develop a logic for a certain rule or hierarchy that would transform and propagate the panel geometry into different variations that would adopt those environmental factors into the generative process. Figure 8 shows an example of a form generation strategy developed based on the findings from the material exploration phase.

Another challenge for the students was to develop a pattern language for the façade composition after being immersed in the exercise of a single panel. This forced the students to develop strategies both at the local parameter level (individual panel) and the global parameter level (overall façade composition). Local parameters included panel vertices, panel thickness, radius of panel voids, number of panel voids, spacing between voids, panel defining curves, panel defining surfaces, etc. For the overall façade composition, some of the global parameters identified were distance between panel centroids, overall solid/void percentage, profile of façade surface (for each of its defining edges), overall surface thickness, etc. (Figure 9).

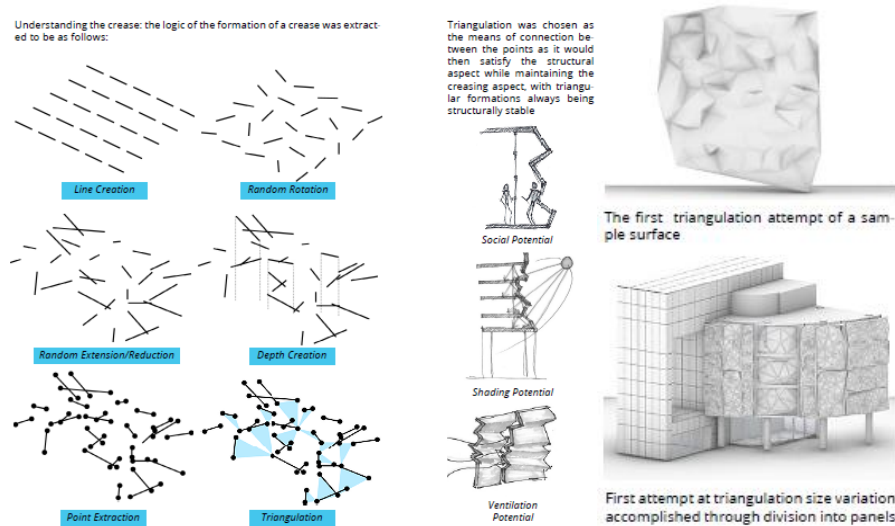

Figure 8. Examples of outcomes in Phase 2: The Parametric Facelift, reflecting the understanding of material properties and surface geometry from Part 1 and using the deduced parameters to create the form generation strategy for the façade panel propagation. [Photo credit: Maram Zeitoun]

In addition, students developed a logic for the panel propagation along the façade surface. Approaches included packing strategies, weaving strategies, blending strategies, and tiling and subdivision strategies. As most of the students commenced their process with a logic related to environmental, spatial, and functional considerations, they spent considerable time linking

the logic of their panel propagation to the objectives they set up front. This was a challenging exercise that required back-and-forth adjustments and iterations, and forced the students to continuously document their process and extract multiple strip plans and sections to test the validity of their double skin ideas spatially, environmentally and functionally. Upon the reflection of the students in this phase, most students explained that this process was a unique process that as extremely different to what they were traditionally used to. They also acknowledged the added value of algorithmic thinking in the creative design exploration process, in generating designs that are responsive to their users and the built environment, and in validating the effectiveness and efficiency of their designs and parametric strategies and achieving their set goals through an iterative process of continuous adjustment, iteration, and reflection.

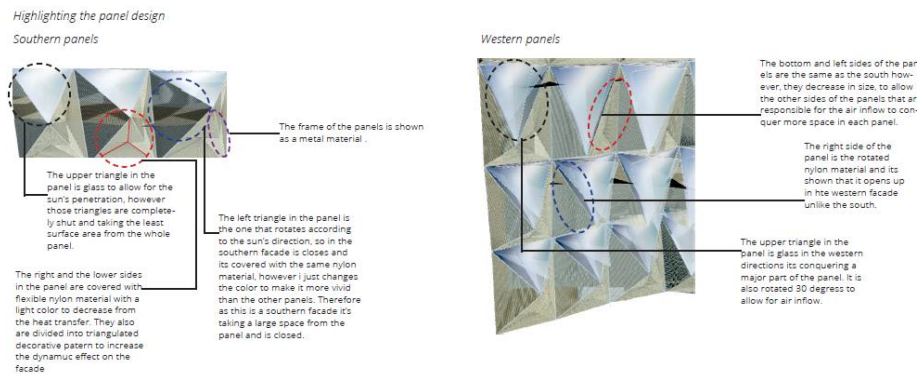

Figure 9. Complexity of applying the parameters deduced from the material exploration phase to the façade composition and detailing, both at the local (individual panel) and global parameter level (overall façade composition). [Photo credit: Mayan Abdalla]

The student process and outcomes in both phases of the course confirmed the initial hypothesis of this paper, where the more explicit the material exploration and identification of physical rules, parameters, constraints, and relations, the more nuanced and grounded the parametrically driven process, where students expressed an appreciation of process, algorithmic thinking, and a clear and goal oriented generative logic, in addition to utilizing parametric design to inform form finding as a bottom-up approach.

Conclusion

This paper presented the process and outcomes of a computational design course with the primary objective of addressing the interplay between making and the physical interplay of materials on the one hand and the process of parametric form finding on the other, and how hands-on

MATERIAL-BASED PARAMETRIC FORM FINDING: LEARNING PARAMETRIC DESIGN THROUGH COMPUTATIONAL MAKING

experience with materiality affects student learning and understanding of principles of algorithmic thinking and parametric form finding.

The course comprised two phases of physical/digital exploration: (1) physical exploration with different materials and fabrication techniques, and (2) deducing and developing an understanding of rules, parameters, relationships and constraints, based on the interplay of materials and applied techniques. Based on the findings and student outcomes, it was observed that the more explicit the material exploration and identification of physical rules and relationships, the more nuanced and grounded the parametrically driven process, where students expressed a clear and goal oriented generative logic, in addition to utilizing parametric design to inform form finding as a bottom-up approach.

References

- DEWEY, J., 1997. *Experience and Education*. New York: Touchstone (first published 1938).
- EL-ZANFALY, D., 2015. Imitation, Iteration and Improvisation: Embodied Interaction in Making and Learning. *Design Studies*, 41, 79–109.
- GRAMAZIO, F. & KOHLER, M., 2008. *Digital Materiality in Architecture*, Lars Muller Publishers, Baden, Switzerland.
- KARPPINEN, S., KALLUNKI, V., & KOMULAINEN, K., 2017. Interdisciplinary Craft Designing and Invention Pedagogy in Teacher Education: Student Teachers Creating Smart Textiles. *International Journal of Technology and Design Education*, 29, 1–18.
- KNIGHT, T., & VARDOLU, T., 2015. Computational Making. *Design Studies*, 41A, 1–7.
- KOLAREVIC, B. & KLINGER, K., 2008. *Manufacturing Material Effects Rethinking Design and Making Architecture*, Routledge, New York, 196-198.
- KOLB, D. A., 1984. *Experiential Learning: Experience as the Source of Learning and Development*. New Jersey: Prentice Hall.
- MEGAHED, N. A., 2013. Towards Math-based Architectural Education in Egyptian Engineering Faculties. *Nexus Network Journal*, 15(3), 565–581.
- MENGES, A., 2016. Computational Material Culture. *Architectural Design*, 76-83.
- MOHOLY-NAGY, L., 2005. *The New Vision: Fundamentals of Bauhaus Design, Painting, Sculpture, and Architecture*. Mineola: Dover Publications.
- OXMAN, N., 2010. *Material-based Design Computation*. PhD Thesis, Massachusetts Institute of Technology.
- OXMAN, R., 2012. Informed Tectonics in Material-Based Design. *Design Studies*. 427-455.
- OXMAN, R., 2017. Thinking Difference: Theories and Models of Parametric Design Thinking. *Design Studies*, 52(2017), 4–39.
- OZKAR, M., 2007. Learning by Doing in the Age of Design Computation. In *Proceedings of the 12th CAAD Futures International Conference*, pp. 99–112.
- YAZICI, S., 2019. Rule-based Rationalization of Form: Learning by Computational Making. *International Journal of Technology and Design Education*. 30, 613-633.
- YAZICI, S. & TANACAN, L., 2020. *Journal of Building Engineering*. 32, 101543.

X-MAX | A DIGITALLY FABRICATED, COMPONENT-BASED, SCRAP METAL ASSEMBLY

MICHAEL GEORGIU, ODYSSEAS GEORGIU

University of Nicosia, Michail Georgalla, Engomi, Nicosia, Cyprus

Email address: georgiou.mi@unic.ac.cy

SEAMLEXITY, Ifigenias 10A+12, Limassol, Cyprus

Email address: odysseas@seamlexity.com

AND

PAVLOS FEREOs

University of Innsbruck, Technikerstraße 21, Innsbruck, Austria

Email address: pavlos.fereos@uibk.ac.at

AND

EFTIHIS EFTHIMIOU

University of Nicosia, Michail Georgalla, Engomi, Nicosia, Cyprus

Email address: eftimiou.e@unic.ac.cy

Abstract. The paper presents the outcome, titled X-MAX, of an educational, intensive 2-week workshop that focused in digitally fabricated, 3D component-based, non-Euclidean geometries using sheet metal forming. Related case studies are analyzed, compared, and grouped to identify the position and contribution of the research in the field. Early design proposals are compared and evaluated based on the hypothesis that improvements in material efficiency and construction/fabrication logistics can contribute towards more affordable design solutions. The fittest solution is further developed and optimized for construction, resulting in a full-scale prototype demonstrating expedited assembly times and decrease in manual labor with parallel savings in material resources. A purposely built design workflow is supported by a comprehensive computational model, enabling information input and output and control via various design parameters. The methodologies of registering scrap sheet metal for fabrication and simulating material bending behavior implementing K-factors are presented and discussed as novel and integral parts of the above workflow.

Keywords: *Digital Fabrication, Computational Design, Sheet Metal Forming, Material Efficiency, Construction Logistics*

ملخص. تقدم هذه الدراسة نتيجة ورشة عمل تعليمية مكثفة استمرت لمدة أسبوعين بعنوان X-MAX ركزت على الأشكال الهندسية غير الإقليدية القائمة على المكونات ثلاثية الأبعاد باستخدام تشكيل الصفائح المعدنية. يتم تحليل دراسات الحالة ذات الصلة ومقارنتها وتجميعها لتحديد موقف ومساهمة البحث في المجال. تتم مقارنة مقترحات التصميم المبكرة وتقييمها بناءً على الفرضية القائلة بأن التحسينات في كفاءة المواد ولوجستيات البناء / التصنيع يمكن أن تساهم في تصاميم حلولها أقل تكلفة. تم تطوير وتحسين أنسب حل للبناء ، مما أدى إلى نموذج أولي شامل يوضح أوقات التجميع المعجلة وتقليل العمل اليدوي مع توفير مواز في الموارد المادية. يتم دعم سير العمل من خلال نموذج حسابي شامل خاص ، مما يتيح تداول المعلومات والتحكم عبر معايير التصميم المختلفة. تم تقديم منهجيات تسجيل الخردة المعدنية للتصنيع ومحاكاة سلوك تقويس المواد بتنفيذ عوامل K ومناقشتها كأجزاء جديدة ومتكاملة من سير العمل أعلاه.

الكلمات المفتاحية: التصنيع الرقمي ، التصميم الحسابي ، تشكيل الصفائح المعدنية ، كفاءة المواد ، لوجستيات البناء

1. Introduction

The paper presents the outcome of an educational, intensive 2-week workshop that focused in digitally fabricated, 3D component-based, non-Euclidean geometries using sheet metal forming. The design brief encouraged explorations of surface composition and articulation, resurged by mass customization, and supported by digital fabrication, and parametric design tools (Kaplan, D., 2011). Furthermore, the question of affordability in complex architectural forms was posed, and it was hypothesized that the areas of material efficiency (Agustí-juan I, Haberta G., 2016), and fabrication/construction logistics (Georgiou M, Georgiou O., 2019) were prominent topics for investigation towards more sustainable design solutions.

Scrap mild steel in sheet form was chosen as construction material to investigate and support the above hypothesis. Registering leftover steel parts as to be usable for digital fabrication presented an essential task that required computational focus. UAVs were implemented and computational tools were developed for automating and optimizing the registration process.

Students consequently worked in teams to produce a set of design proposals according to the given brief. They were requested to design for CNC machines and develop an understanding of materials, possibilities, and restrictions towards realizing an idea using digital fabrication techniques. Additionally, the participants explored and experimented with the creation of computational models using Computational Design tools to comprehend the notion of computer simulation of complex geometric problems. Physical Modelling experiments in the view of precedents were compared with computer generated ones and reproduced using digital fabrication methods. Such processes were implemented for testing material properties and

tolerances as the means for developing and fine-tuning the end results. Prototyping with both physical and virtual models has driven a bottom-up process generating 3D component-based assemblies, guided by several constraints, to shape design solutions and evaluate their fitness. During the process, each team had to comply and account for several design and fabrication parameters such as material type (mild and/or galvanized steel), material thickness, bends/creases, perforations, tolerances, jointing techniques, assembly methodology and assembly time.

The proposals were finally evaluated based on their contribution to the areas of material efficiency, and construction/fabrication logistics. The successful design was further developed into a full-scale prototype demonstrating creditable benefits in logistics resulting in expedited assembly times and decrease of manual labor compared to equivalent research prototypes (Georgiou M, Georgiou O., 2015 and Georgiou M, Georgiou O., 2019). In parallel contributions to the areas of material resources optimization were identified in the use of scrap metal sheet for digital fabrication, the absence of a secondary structural system and the minimization of additional jointing material/system. The project was supported by a comprehensive computational model, central to a purposely built workflow, enabling design information input and output (Figure 1).

The research activity was part of the curriculum of the 1st semester of the Distance Learning MSc Programme in Computational Design and Digital Fabrication, of the University of Nicosia in collaboration with the Institute for Experimental Architecture - Hochbau of the University of Innsbruck.



Figure 1. X-MAX and design team

2. Literature Review

Sheet metal forming in medium and large-scale architectural installations has been increasing over the past decade, assisted by the proliferation of digital fabrication machinery and methods. By comparing related case studies, differences and similarities with X-MAX were asserted, both prior and after the project's completion. For the purposes of this research the above-mentioned case studies have been grouped into two main categories explained below.

In parallel, as no other project using scrap sheet metal has been encountered, this approach of the research is explicitly analyzed and presented. Although a lot of time and effort has been devoted to this part during the project, it can be argued that any structure built with scrap material can also be built with new material. Therefore, the design process presented cannot necessarily be defined reversibly by the principle of using scrap material, apart from limited design constraints resulting in creative ornamental pattern solutions.

The first group of projects employing sheet metal forming is aiming to create surface continuity via assembly of pleated metal panels akin to origami techniques (Jackson P., 2011). The ARUM Installation piece at the Venice Biennale 2012 by Zaha Hadid Architects (in collaboration with RoboFold and others) employs robotic fabrication for bending sheet metal along curved edges, to realize a continuous surface structure without any sub-structure required. Similar design principles, but with flat profiles instead of curved shaped or curve-bending profiles can be found at the Origami Pavilion by Tal Friedman which required internal substructure for support, and the Photoptosis Installation by OrProject which achieves a self-supporting surface structure made of thin-shell folded sheets.

The second group of projects which employ sheet metal forming techniques (Incremental Sheet Forming with bent edges or pressure forming) present a component-oriented approach during their research and design process, therefore resulting in aggregation type of outcomes or component repetition. In most of these cases a substructure is required. Such cases are AA EmTech Design & Build Pavilion in 2018 and the Ninety-Nine Failures Pavilion of The University of Tokyo Digital Fabrication Lab.

Apart from the ARUM project where the bending angle degree and accuracy is controlled by robotic arms, the rest of the projects above employ a manual bending process after the sheets have been creased. Reason being that the actual angle of the bended edge-joint is irrelevant if the adjoining component has the inverse angle (e.g., 70-110 degrees). In most of the cases that angle can be manipulated manually on-site making the requirement for accuracy less important.

Based on the above analysis, the workshop research brief framed a design solution that would not be initiated or result in a continuous skin structure (first group), would prioritize material forming accuracy and would be self-supported despite utilizing components made of sheet metal of only up to 2mm in thickness. Additionally, contributions to the field can be identified in the registration and use of scrap metal and the employment of a CNC press brake, a relatively common CNC fabrication methodology but not frequent in architectural installations employing sheet metal forming.

As such the research team prescribed a bottom-up design process originating from the individual component, its connectivity and structural performance to reach the outcome. The design approach steered-away from top-down solutions of triangulating or paneling a predefined skin/surface. Instead, the individual component and its intrinsic properties guided the generation of a surface able to achieve self-stability and spatial qualities such as 3dimensionality, porosity and increased transparency.

It is important finally to be stated that, much like the Ninety-Nine Failures Pavilion constitutes “a conceptual and practical vehicle for generating a series of challenging computational design questions instead of finding straight-forward engineering solutions to some structural or material related problems” (RAFAEL A. BALBOA & ILZE PALKONE, 2013), the X-MAX utilizes computational solutions and fabrication techniques oriented more on the educational effect of their implementation. Nevertheless, the above statement does not exclude further research and possible applications in the construction industry, such as the architectural screens domain notably explored by Erwin Hauer.

3. Design Evaluation

As mentioned above, participants were requested to follow a bottom-up design approach. As such they were asked to define a component, its characteristics and connectivity to neighboring units before proceeding to propose an overall assembly. Three teams were formed proposing the following component systems (Figure 2)

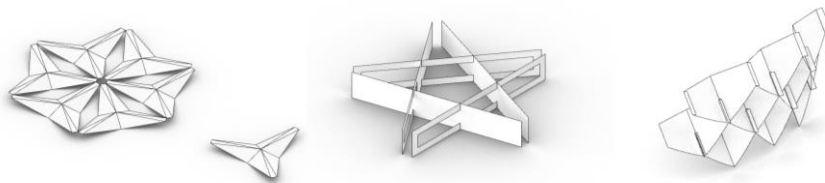

Figure 2. Proposed Component Systems A, B and C (from left to right)

X-MAX | A DIGITALLY FABRICATED, COMPONENT-BASED, SCRAP METAL ASSEMBLY

Component system A presented a complex bending articulation involving nine bends to form a tripod pleated part. A set of six such components would come together to form a larger hexagonal element. The assembly of these components would require a fair number of additional joints between the triangular components and between the consequent hexagonal parts. The joints' complexity would be defined by the intricacy of the overall shape. The assembly would also require a separate support system as there was no clear force pathway to the ground. Due to the increased number and complexity of the component, creasing, using a laser-cutter, was suggested as a bending method, which would require an additional effort for manually forming individual angles. The triangular component could result in an efficient nesting of parts for digital fabrication. The tessellation would potentially create interesting results but was lacking 3dimensionality.

Component system B presented a simpler unit with no bends. Further development introduced bend parts by joining members of the structure that would enhance structural performance and rigidity. The idea would involve two or more parts coming together in a planar formation using a slotted joint system to form star-shaped components. Assuming sufficient tolerances and by utilizing the inherent active-bending properties of the material, the proposal could result in an efficient jointing system that could require minimal assembly effort and no additional components/fasteners. The specific proposal did not account for surface articulation but proposed a vertical stacking of components to produce the overall assembly which would require no additional support. The stacking would potentially create interesting results but was lacking 3dimensionality. Nesting could be relatively efficient since the proposal involved only rectangular elements and reduction of material could be achieved by removing parts wherever not needed. However, the latter process would not necessarily result in material efficiency as the removed pieces would be relatively small and not usable.

Component system C presented a relatively simple unit with three bends that contributed to its rigidity. Two of the above bends were identical for each component. The advantage of the proposal was identified to the connectivity method of the component to its neighboring units and the simple jointing system that it entailed; components in rows would be bolted together while a slotted joint, secured by the self-weight of the structure, was proposed along the Z-direction. Furthermore, the alternating arrangement of the components in every successive row provided a scissor-like configuration which enhanced lateral stability while creating a 3dimensional porous effect. Assuming certain limitations in overall shape, the assembly suggested a surface articulation with vertical stacking for transferring loads to the ground. Nesting of units for digital fabrication did not present an

advantage for this specific solution due to the V-shape of the unfolded component, but it presented an opportunity for packing optimization.

Following the above evaluation, component system C was selected for further development and optimization as it contributed to both the areas of material efficiency (component rigidity via limited bending, clear load transferring pathways and minimization of joints) and construction/fabrication logistics (clear assembly process and minimization of joints). Furthermore, the propose solution would facilitate surface composition supporting spatial qualities such as 3dimensionality, porosity and transparency as outlined by the workshop brief.

4. Prototype

The outcome of the development process was titled X-MAX and was generated by populating a single, adaptable 3D component to form an efficient self-supported doubly curved structure. 190 components were developed into load-bearing modules that could be digitally fabricated out of flat sheets of material and then CNC bent in shape using variable bent angles. Modules were connected using bolts to form circular rings that could be vertically stacked and secured using the self-weight of each row. The modules were made using galvanized and mild steel of 2mm, 1.5mm and 1.0mm in thickens, and were arrayed forming an ascending pattern (Garcia M., 2009). The installation weighed 250 kg, its footprint ranged at 2.4m² and its height to 4m. All parts were assembled in a puzzle-like routine in 8 hours over a period of a day, by a team of ten students. The assembly time and manual effort were substantially lower, compared to the construction of equivalent research prototypes (Georgiou M, Georgiou O., 2015 and Georgiou M, Georgiou O., 2019). The structure was disassembled and reassembled, a week after the initial setup, by a smaller team of volunteers to be donated to the Local Municipality. It is currently hosted as a public installation at the main square of the city.

5. Scrap Metal Registering

In the process of registering and creating a library of all scrap material available, the research team faced a series of challenges that produced a workflow with distinct problem-solving steps. The first step involved capturing quality images, capable of later being translated into vector files with a high degree of precision.

Towards this direction, the scrap material was documented with orthophotography, implemented with the use of a UAV (drone). To

X-MAX | A DIGITALLY FABRICATED, COMPONENT-BASED, SCRAP METAL ASSEMBLY

minimize lens distortion, the UAV was mounted with a camera bearing a zoom lens (200 mm). The objects were placed on a rectangular base (green sheet) of known dimensions. Markers were set on each corner and middle points of the outline of the rectangle with the use of a laser plane. Those were later used to further correct lens distortion through raster deformation techniques and assess the creation of an orthographic image.

The next step was the automated cleanup of the image files. This required the implementation of a denoising algorithm (Martin et al., 2018), as well as a Gaussian blur function (Haddad, Richard and Akansu, Ali., 1991), with the main purpose to avoid translating surface imperfections and JPEG artifacts to the vector model. This led to smoothly colored image files, ideal to be traced. (Figures 3a and 3b)



Figure 3. orthophotography, *a.* unedited, *b.* with denoising and gaussian blur

However, since the design incorporated three different types of material with variable hue, a simple threshold workflow for the tracing of vector graphics was bound to create inaccuracies. For this reason, an extra step of an edge detection algorithm was called for. An edge in a raster dataset is where the intensity of the values changes abruptly. Edges can be found at the boundary of objects, such as the scrap material we are referring to, provided there is an appropriate contrast with the background material. After a series of trial and error, the “Sobel operator” (Sobel I., 2014) was selected, this gave results of maximum clarity. The images at this point were ideal for tracing, mostly black, with well proclaimed light-colored edges.

The next step was the vector tracing of the treated images. To achieve this task, the team utilized a well-known open-source polygon-based image tracing algorithm, called “Potrace”, by Peter Selinger (Selinger P., 2003), as compiled for Rhinoceros 3d (Bouteau G., 2018), based on a C# translation by Wolfgang Nagl. The tracing algorithm creates a double outline, one for each side of the light-colored edge. The inner outline was selected, to increase the tolerance for the nesting phase, further down the process. The

curves were then simplified and reduced, by removing least significant vertices, based on a set tolerance value. The traced outlines were then brought into scale through the known dimensions of the outline rectangle. The outcome was cross-referenced to several known dimensions in specific scrap parts, to ensure an overall deviation of less than 0.4%. The scrap parts were numerically tagged by sorting the Euclidean coordinates of their centroids (x, then y, then z), both manually during the photoshoot, as well as computationally during the library creation stage.

6. Simulating Sheet Metal Forming

Another task imposed by the project brief was to computationally simulate the material deformation produced by the chosen forming methods. As opposed to common digital fabrication methods, namely additive manufacturing, or subtractive manufacturing, where machined pieces do not tend to deform to such extent, in sheet metal forming this deformation is usually large enough to surpass the design tolerances. For this reason, the performance of the material and its exact geometry, both flat and in its final state, needed to be simulated and embedded in the computational model.

The boundaries of the task were defined by the material and fabrication method. The material was set as mild and galvanized steel of thicknesses 1.0mm, 1.5mm and 2mm. Both metals have similar ductility and therefore analogous bending properties. The fabrication process, sheet metal forming, was carried out using a CNC Die Bending Press brake.

In the process of bending sheet metal (or any other ductile material) the outer fibers stretch and elongate whereas the inner fibers compress and shorten. The only fiber that remains the same is what is called the neutral axis, which is defined by the K Factor. K factor is a function of the thickness and the properties of the material. The layer, which is unrolled flat, to form the fabrication layout, is the one corresponding to the neutral axis. Defining this surface would produce a precise machined piece which when formed would correspond to the exact 3d shape drawn.

The K-Factor, defining the neutral axis is, according to the Fabricator, (Benson, 2018) calculated by bending several test pieces. with the exact properties of the material to be used and measuring the Bend Allowance (Figure 6b) and correspondingly the setbacks of the material. The K-Factor is calculated by the formula:

$$K = \frac{(180 \times BA)}{(\pi \times \text{Bend angle complementary} \times Mt)} - (Ir/Mt) \quad \text{(Equation 1)}$$

Where Mt = material thickness and Ir is the desired inside bending radius.

X-MAX | A DIGITALLY FABRICATED, COMPONENT-BASED, SCRAP METAL ASSEMBLY

The above formula needed to be verified for a range of bend angles to make sure that any deviation from the theoretical design was within tolerance. This process generated a single K-factor required as input for the computational model for the two different materials, mild and galvanized sheet metal for thicknesses up to 2mm and a bending radius equal to the thickness of each sheet.

7. Computational Modelling

Throughout the development, fabrication and assembly stages of the project, a single computational model was central to a purposely built workflow enabling design control and information input and output (Figure 4).

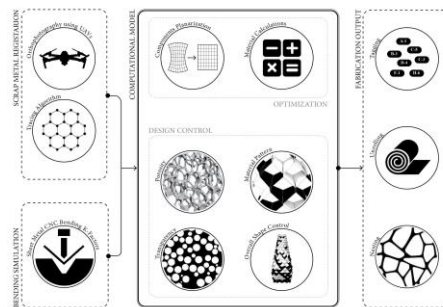

Figure 4. Computational Workflow Diagram

Once the individual component and its organizational logic were formulated, the base shape geometry, a doubly curved surface, was generated as a convex object of revolution, produced by rotating a section curve around a central Z-Axis. The control of the shape was performed by altering a height parameter and by modifying the section curve. The obligation for a convex shape was derived by the nature and jointing technique developed for the individual module that could not be applied to concave shapes as it would result in colliding components.

Having control over the base shape was crucial for the development process as on one hand there was a finite amount of material and on the other hand clashes between the components would only be revealed as the design was further progressed. Furthermore, the structural constraints for self-stability, suggested components that could transfer forces along the vertical direction and therefore directed the formation of the final shape. A seemingly simple but challenging to compute, staggering pattern, was developed, alternating between each row of components. This staggering pattern facilitated the assembly of the structure by enabling simple slotted joints between each row of components (Figure 5a).

For the above operation, a grasshopper plugin was implemented, paneling tools, that would enable the formation of a staggered grid to host the two alternating sets of components. (Figure 5b)

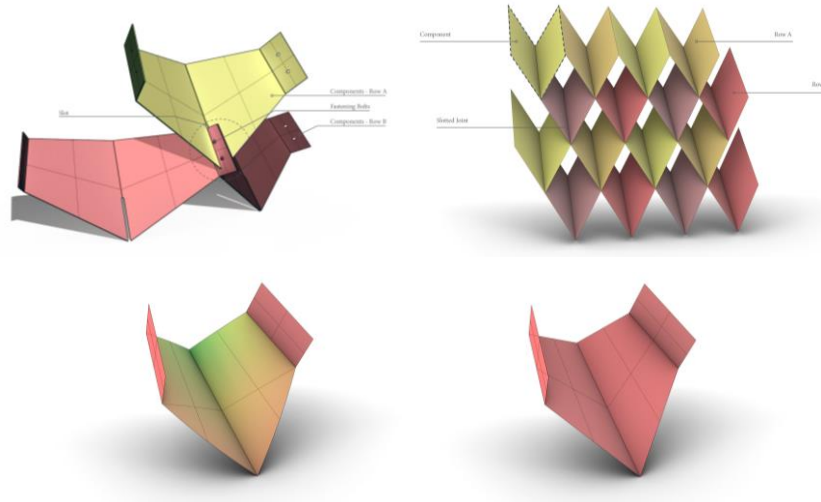

Figure 5a. Prototype Joints, 5b. Staggering Pattern Diagram, 5c. Gaussian curvature analysis for the initial morphed component and the rationalized outcome (from left to right).

Morphing, an automated process enabling the mapping of 3D shapes from an initial bounding Box into a twisted one, was implemented to tessellate the components onto the base geometry. Even though the above process resulted in components with non-planar surfaces, it was deemed the most efficient method for achieving the staggering pattern.

Due to the warping on the doubly curved surface, the components developed into non-planar elements. For addressing the non-planarity of the components, a planarization algorithm was implemented to amend the above issue. The algorithm would rebuild all components based on the faces' mean plane, minimizing the deviation from the initial shape. The algorithm also allowed for collision control on the slotted joints thus ensuring that no bolts would interfere with the neighboring component. (Figure 5c)

At this point, the K-factor application explained earlier was successfully implemented in the algorithm to enable the appropriate fillets and surface offsets wherever bending was occurring. As such, each component's bends were automatically shaped according to material thickness and corresponding to K-factors, ensuring that the unrolled cutting layouts would have the exact shape corresponding to the 3D model (Figure 6a). The algorithm was also capable of exporting 3D Fabrication files in STEP format to verify that the unrolled shape was correct. The verification took place in Autodesk Inventor Software, inputting the CNC Press Brake's preferences.

X-MAX | A DIGITALLY FABRICATED, COMPONENT-BASED, SCRAP METAL ASSEMBLY

In addition to the above, the design team introduced another set of rules incorporating the use of attractor points, to enhance the appearance and 3-dimensionality of the structure. These parameters were used to achieve the desired porosity, transparency and pattern formation while maintaining the structural stability and constructability. Variable Porosity was achieved by scaling each row of components in the Z-direction, thus creating a subtle vertical undulating effect, immediately noticeable at the seemingly yielding base of the structure. Equally the components enabled variable openings on their core surface thus also affecting the overall transparency of the structure, an effect that is mostly visible in the center of the vertical axis of the project.

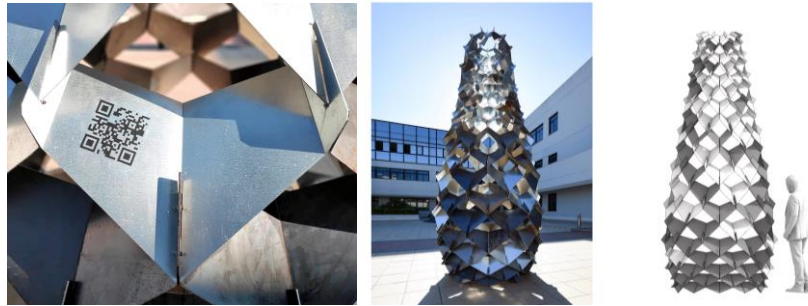

Figure 6a. Component with the K- Factor and sheet bending properties applied and 6b. galvanized and mild steel pattern (from left to right).

The availability of both galvanized and mild steel as raw material resulted in two visually distinct types of components. This property of the structure was further enhanced and turned into a design opportunity with which students experimented to produce an ornamental pattern. The chosen solution had most mild steel components at the base, creating a random transitioning effect towards galvanized components at the top (Figure 6b). The proposal was based on the amount of available material as well as creating a glossy effect at the top of the structure. The foreseen natural corrosion of the untreated mild steel as opposed to the galvanized steel components further highlighted the ascending pattern formed by the varied materiality while suggesting an inherent ageing activity.

The shuffling of the different types of sheet metal corresponding to the components posed a logistics' challenge to the design team. While a single material approach required registering tags only on component rows, the material differentiation called for a more complicated tagging and nesting process. The Grasshopper3D definition handled this task, following the chosen pattern of components, considering the Material, Thickness, and location of each component, unrolling all shapes flat and nesting them onto the appropriate sheet.

8. Conclusion

The paper presented the outcome of an educational, intensive 2-week workshop that focused on digitally fabricated, 3D component-based, non-Euclidean geometries using sheet metal forming.

Based on literature review, related case studies have been analyzed, compared, and grouped therefore identifying the position and contribution of the presented research project in the field. As such, the characteristics of a bottom-up component-based design approach which prioritizes material forming precision along with self-supporting ability have been recognized as novel. Additionally, contributions to the field can be identified in the registration and use of scrap metal and the employment of a CNC press brake as a fabrication method.

Following the evaluation of a series of early design proposals, the solution that contributed to the areas of material efficiency and construction/fabrication logistics was further developed and optimized for construction. The full-scale prototype demonstrated creditable benefits in logistics resulting in expedited assembly times and decrease in manual labor compared to equivalent research prototypes. In parallel contributions to the areas of material resources optimization were identified in the use of scrap metal sheet for digital fabrication, the absence of a secondary structural system and the minimization of additional jointing material/system.

The registration of leftover steel parts as to be usable for digital fabrication, presented a significant part of the process involved. Automating the process using computational tools was presented and discussed. In parallel, the computational definition of the bending behavior of the material and the implementation of K-factors in the workflow, provided the basis upon which the design process was carried forward.

A purposely built design workflow was implemented, supported by a comprehensive computational model, enabling control through various parameters. The process has facilitated a complex 3D tessellation of components on a doubly curved surface along with the exploration of design solutions involving variable porosity, transparency, and materiality patterns. The computational workflow supported the input of the registered material and its bending behavior while enabling automatic generation of the digital fabrication output.

While the research presented in this paper derives from an educational perspective, further analysis and possible applications could focus on the construction domain. As such the areas of leftover material registration, expanding in both hardware and computational explorations, and further enhancing the structural integrity of the material through comprehensive control of the bent creases could be explored.

Acknowledgments:

The project was supported by the University of Nicosia, Andreou Laser and SEAMLEXITY. We thank the MSc CDDF Fabrication Assistant Christoforou C. and the Students: Alsawadi A., Anatolianos S., Badran A., Balampanidis A., Kakouri S., Kasmaei H., Kyriakides K., Menardo A., Tuttle M. and Zakeri H. who participated in the design and realization of the project.

References

- AA EM TECH, 2018, *Design & Build Pavilion*, [online] Available at: https://www.youtube.com/watch?v=MvKZBDyUo7Y&ab_channel=AASchoolofArchitec ture [Accessed 15 Nov. 2020]
- AGUSTÍ-JUAN I, HABERTA G., 2016. *An environmental perspective on digital fabrication in architecture and Construction*, CAADRIA, 797–806, Hong Kong.
- BENSON, S., 2018. *K-factors, Y-factors, and press brake bending precision*. [online] Available at: <https://www.thefabricator.com/article/bending/k-factors-y-factors-and-press-brake-bending-precision> [Accessed 07 Nov. 2020]
- BOUTEAU G., 2018. *TRACE*, [online] Available at: <https://www.food4rhino.com/app/trace> [Accessed 07 Nov. 2020]
- GARCIA M., 2009. *AD: Patterns of Architecture*, John Wiley & Sons, 0470699590
- GEORGIOU M, GEORGIOU O., 2019. '*BLOOM – Materializing Computational Workflows*', GSM4Q 2019, Qatar University, Doha, Qatar.
- GEORGIOU M, GEORGIOU O, WILLIAMS C., 2015. '*Iterating towards Affordability*', Design Modelling Symposium 2015, Modelling Behaviour, Springer, ISBN: 978-3-319-24206-4, pp.517-526, Copenhagen.
- HADDAD, RICHARD & AKANSU, ALL., 1991. *A class of fast Gaussian binomial filters for speech and image processing*. Signal Processing, IEEE Transactions on. 39. 723 - 727. 10.1109/78.80892.
- HAUER E., *Installations* [online] Available at: <http://erwinhauer.com/eh/installations/>
- JACKSON, P., 2011. *Folding Techniques for Designers: From Sheet to Form*, Laurence King Publishing; Mac Win Pa edition, 1856697215.
- KAPLAN, D., 2011. *Safavid Surfaces and Parametricism*. [online] Available at: <http://archinect.com/features/article/29553480/safavid-surfaces-and-parametricism> [Accessed 07 Nov. 2020]
- MARTIN ET AL., 2018. *A Comprehensive Survey on Impulse and Gaussian Denoising Filters for Digital Images*. Signal Processing. 157. 10.1016/j.sigpro.2018.12.006
- OR PROJECT, 2017, *Photoptosis*, [online] Available at: <https://orproject.com/photoptosis/> [Accessed 15 Nov. 2020]
- RAFAEL A. BALBOA & ILZE PALKONE, 2013, *Ninety-One Failures and One Pavilion*, [online] Available at: https://www.academia.edu/5796532/99_Failures_and_One_Pavilion [Accessed 15 Nov. 2020]
- SELINGER, P., 2003. *Potrace: a polygon-based tracing algorithm*. [online] Available at: <http://potrace.sourceforge.net/potrace.pdf> [Accessed 07 Nov. 2020]
- SOBEL, I., 2014. *An Isotropic 3x3 Image Gradient Operator*. Presentation at Stanford A.I. Project 1968.
- ZAHA HADID ARCHITECTS, 2012, *ARUM*, Venice Biennale 2012, Available at: <https://www.zaha-hadid.com/design/contribution-to-2012-venice-biennale-theme-common-ground/> [Accessed 15 Nov. 2020].

D2.P1.S2

COMPUTATIONAL ENCULTURATION III

TECHNOLOGY-DRIVEN PARTICIPATORY SPATIAL DESIGN IN A DEVELOPING WORLD CONTEXT: THE CASE OF ISTANBUL

AHMET GÜN, BURAK PAK

*Department of Interior Architecture, Istanbul Technical University,
34437, Istanbul, Turkey*

*Altering Practices for Urban Inclusion Research Group, Faculty of
Architecture, KU Leuven, 1030, Brussels, Belgium*

Email address: ahmetgun@itu.edu.tr

Email address: burak.pak@kuleuven.be

AND

YÜKSEL DEMİR

*Department of Architecture, Istanbul Technical University, 34437,
Istanbul, Turkey*

Email address: demiry@itu.edu.tr

Abstract. Nowadays, ICT-based participatory design methods, techniques and tools are increasingly used across the globe. A majority of these are employed in high-income “developed” countries with advanced democratic systems which aim at including citizens; desires, needs, proposals as valuable input in city-making processes. In contrast, in the Global South, only a limited number of ICT-based practices aim to empower the citizens in urban design and planning at higher instances. There is a need for deeper research into how citizens can be involved in urban design in developing countries like Turkey situated in between the Global North and the South. In this context, this research will focus on Istanbul, Turkey as a key case. Different than the developed world context, enabling ICT-based participation in Turkey has a wide range of challenges. Among those are the lack of open and governmental data and transparency, the unwillingness of the policymakers to promote and employ participatory design, top-down approaches are the other weak points of these countries. Responding to these challenges, the aims of this study are: 1) to critically address the weaknesses and requirements of existing urban development practices in developing countries with a focus on Turkey, Istanbul and 2) to discuss the possible potentials of ICT-based participation tools and techniques to involve citizens in city-making processes.

Within these aims in mind, in this paper, we critically discuss the existing urban transformation practices in Turkey by tracing how these “practices” take place in the field. In the second part of our study, we develop and test two different mobile participation applications in Süleymaniye Urban Renewal Area with the participation of citizens and experts. This study reveals the unforeseen challenges in the context of Istanbul and introduces alternative strategies to address these: 1) “maneuvering” to integrate into and reconsider the existing legal frameworks, 2) introducing and mobilizing new network-actors 3) embedding participatory actions in current practices by placing citizensourcing and expertsourcing at the center of the urban development practices to 4) enabling the inclusion of the citizens with diverse backgrounds in Istanbul.

Keywords: *Participatory design; Information and Communication Technologies (ICTs); Smart Cities; Urban Transformation; Developing Countries; Turkey.*

المخلص. في هذه الأيام، أساليب وتقنيات وأدوات التصميم التشاركي المعتمدة على تكنولوجيا المعلومات والاتصالات (ICT) يتم استخدامها بشكل متزايد في جميع أنحاء العالم. معظم هذه التقنيات يتم توظيفها في بلدان الدخل المرتفع "المتقدمة" ذات الأنظمة الديمقراطية المتقدمة التي تهدف إلى إشراك المواطنين والرغبات والاحتياجات والمقترحات كمدخلات قيمة في عملية إنشاء المدينة. في المقابل، في عالم الجنوب، هناك عدد محدود فقط من الممارسات المعتمدة على تكنولوجيا المعلومات والاتصالات (ICT) تهدف إلى تمكين المواطنين في التصميم والتخطيط الحضري في المستويات العليا. هناك حاجة لإجراء بحث معمق حول كيفية إشراك المواطنين في التصميم الحضري في البلدان النامية كتركيا الواقعة بين عالم الشمال والجنوب. في هذا السياق، سيركز هذا البحث على إسطنبول، تركيا كحالة رئيسية. بخلاف العالم المتقدم، فإن تمكين المشاركة المعتمدة على تكنولوجيا المعلومات والاتصالات في تركيا تنطوي على مجموعة واسعة من التحديات. من بين هذه التحديات الافتقار إلى البيانات المفتوحة الحكومية والشفافية، وعدم رغبة صنّاع السياسة في تشجيع وتوظيف التصميم التشاركي، والنموذج التنزلي هي نقاط الضعف الأخرى لهذه البلدان. استجابة لهذه التحديات، فإن أهداف هذه الدراسة هي: ١- معالجة نقاط الضعف ومتطلبات ممارسات التنمية الحضرية الموجودة حالياً في البلدان النامية بشكل حاسم مع التركيز على تركيا، إسطنبول و٢- مناقشة الإمكانيات المحتملة لأدوات وتقنيات المشاركة المعتمدة على تكنولوجيا المعلومات والاتصالات (ICT) من أجل إشراك المواطنين في عملية إنشاء المدينة. مع وضع الأهداف السابقة في الحسبان نناقش في هذه الدراسة إجراءات التحول الحضري (التحول المدني) الحالية في تركيا بطريقة نقدية وذلك عن طريق تتبع الكيفية التي حدثت بها هذه الإجراءات. وأما عن المرحلة الثانية في الدراسة، فإننا قمنا بتطوير واختبار تطبيقين مختلفين من أجل مشاركة السكان والخبراء في منطقة التجديد الحضري السليمانية عبر الهاتف المحمول. تكشف هذه الدراسة عن التحديات الغير متوقعة (ضمن نطاق إسطنبول) وتقدم استراتيجيات بديلة للتعامل معها ومنها: ١- "المناوره" للاندماج في الأطر القانونية القائمة وإعادة النظر فيها، ٢- إشراك شبكات وجهات فاعلة جديدة، ٣- دمج الكتل المشاركة في الإجراءات الحالية وهم مصدر كتلة السكان ومصدر كتلة الخبراء عن طريق وضعهم في خصم الإجراءات الخاصة في التحول المدني، ٤- ادراج مواطنون من خلفيات متنوعة في إسطنبول في هذه العملية.

الكلمات المفتاحية: التصميم التشاركي؛ تكنولوجيا المعلومات والاتصالات (ICT)؛ المدن الذكية؛ التحول الحضري؛ الدول النامية؛ تركيا.

1. Introduction

Cities around the globe have been facing complex problems such as rapid urbanization and migration, density, insufficient public spaces in the last century. Added onto these, mainly after the wide-spread adoption of internet in everyday life, the management and inclusion of complex and big data surrounding urban issues emerged as an essential challenge. Moreover, while urban governance practices are getting more inclusive and participatory, different stakeholders, citizens, public institutions, governments and companies that have diverse interests have started to demand from the decision-makers to establish well-designed “urban collaboration ecosystems” (UCE). These ecosystems demonstrate the potential to rethink and activate resources to be shared in an equal and just manner while not only enhancing the citizen welfare but also providing a suitable collaboration environment where companies, entrepreneurs, research institutes and local governments can carry out their activities in interactive, effective and efficient ways. In this context, information and communication technologies (ICT) are central to establishing UCEs and provide new opportunities to different stakeholders to co-develop solutions to the important problems that cities are facing (Capdevila and Zerlange, 2015). These technologies not only provide the ways to local governments while managing their resources in an intelligent way but also create new business opportunities so they attract various active players of the city-making and managing process (Bakıcı, 2013). Moreover, they enable tools to decision makers to resolve problematic processes of the previous urban practices in a radical way and help them to connect and managed urban settlements holistically with optimized resources (Geropanta, 2020).

Today, ICTs are commonly used for enabling citizens to involve them in city-related issues. The appropriation of ICT-based tools and technologies, such as web-based platforms, mobile participation apps, PPGIS, crowdsourcing platforms, online participation games, in urban interventions have particularly gained traction in the last two decades. These tools and technologies provide new ways to enable more transparent and inclusive participatory design processes. However, a majority of the ICT-based participatory design methods, techniques and tools are used exclusively in the so-called “developed world”. A majority of these aim at including citizens; desires, needs, proposals as valuable input in city-making processes geared towards cities with high Gross Domestic Product. Only limited research has been conducted in developing countries covering specific case reports. Thus, there is a need for deeper research into how citizens can be involved in urban planning and design in developing countries.

Turkey is an interesting case among others to research due to the urgent need for urban transformation and the lack of meaningful collaboration mechanisms. Different than the developed world context, enabling ICT-based participation in Turkey has a wide range of challenges. Among those

are the lack of open and governmental data and transparency, the unwillingness of the policymakers to promote and employ participatory design, top-down approaches are the other weak points of these countries. In this sense, the aims of this study are: 1) to critically address the weaknesses and requirements of existing urban development practices in developing countries with a focus on Istanbul, Turkey and 2) to discuss the possible potentials of ICT-based participation tools and techniques to involve citizens in city-making processes.

The methodology of this study involved a triangulation of a) literature review informing the construction of a collaborative design model considering the existing urban transformation processes and legislature b) followed by pilot testing of ICT-based participatory design Süleymaniye and c) interviews made with key experts in the area. The literature review involved two stages of investigation. We firstly reviewed the literature discussing the ICT-based participatory design in the context of Smart City. In the second stage (Section 3), we made a critical overview of urban transformation practices in Turkey. Then, we tested two different mobile participation applications in Süleymaniye Urban Renewal Area with the participation of citizens and experts. Afterwards, we carried out focus group interviews with eight external experts about developed ICT-based participatory design model and tested apps in order to get recommendations and address requirements for further development.

In order to address the stated research questions, this paper is organized in the following structure. First, we will offer a critical overview of ICT-based participation in the context of Smart City technologies. Here, the main components of Smart City strategies will be examined/explored within the scope of citizen participation. Then, the existing urban transformation practices of Turkey will be analyzed by identifying the conflicts and problems that have witnessed up to now. This section is based on our previous study that has already been published (Gün, Pak and Demir, 2020). In Section 4, we will demonstrate the features and design elements of two different mobile participation applications, which was designed individually for two target groups: citizens and experts. These apps have been tested with the help of architecture students and experts who have different professional domains. Following the discussion of the findings, we summarize the questions, feedbacks and suggestions given by experts and users and the test results. Conclusions and further research directions in this area are presented in Section 5.

2. ICT-based Participatory Design in the context of Smart City technologies and its implications for the Developing World Context

As the volume of data about urban-related issues has increasingly grown and cities have embedded with comprehensive digital networks, sensors,

TECHNOLOGY-DRIVEN PARTICIPATORY SPATIAL DESIGN IN A DEVELOPING WORLD CONTEXT: THE CASE OF ISTANBUL

smart city technologies have gained traction as a vision for supporting innovation and providing an efficient and sustainable urban development and management (Kitchin, 2014). The concept of “smart city” can be defined as “*a well-defined geographical area, in which high technologies such as ICT, logistic, energy production, and so on, cooperate to create benefits for citizens in terms of well-being, inclusion and participation, environmental quality, intelligent development; it is governed by a well-defined pool of subjects, able to state the rules and policy for the city government and development*” (Dameri, 2013, p. 2549). Smart city technologies are used to describe various instances in urban areas: web portals that virtualize cities; knowledge bases identifying local needs; agglomerations with ICT infrastructure that attract business relocation; ICT infrastructures that provide e-services to the citizens; ubiquitous environments; and ICT infrastructure for ecological use (Anthopoulos, 2015).

Giffinger et al. (2007) classifies six components of “smart cities”: smart economy, smart people, smart governance, smart mobility, smart environment, and smart living. Smart governance and smart people are critical characteristics of smart cities that are closely related to citizen empowerment by providing required tools and services to citizens so that they can involve actively in urban-related issues. While smart people concept have several attributes like social and ethnic plurality, flexibility and participation in public life (Nam and Pardo, 2011), smart governance enables transparent ICT-based government activities, provides e-services to empower citizens and involve them in public management (Neirotti et al., 2014).

Even though smart city technologies provide lots of opportunities, they have been criticized for several reasons as following:

- The lack of clear strategies that should be followed regarding people engagement and citizens are not more than observation objects rather than active participants in the creation of urban areas (Geropanta, 2020). This will possibly cause that the future smart city technologies will reflect narrow corporate and state visions, rather than the desires of wider society (Kitchin, 2014).
- Smart city approaches have generally been related to top-down processes of technology diffusion rather than bottom-up processes (Capdevila and Zarlenga, 2015)
- The tendency to believe that the implementation of technology can automatically transform the city into a “smart city” by hindering the clarification of many subjects (Angelidou, 2014)
- These technologies are exponentially used to solve the challenges of the Global North (Geropanta, 2020). The use of these technologies in developing countries and in the Global South, where the community faced serious urban problems such as urban infrastructure, sanitation, natural disasters, is still very limited.

As stated above, a majority of the smart city technologies have only provided limited bottom-up, participatory urban development and management processes so far. Moreover, even though in European countries where there are a lot of law items, such as Finland Land Use Planning Act (1999) and UNECE Convention (1998), regarding participatory design have been enacted, there are still some problems about the key factors to carry out successful participation process. As Gün, Demir and Pak (2020) revealed, only a limited number of ICT-based participation platforms provide suitable design environments for user experience, adopt strategies to enable representation equality and trust mechanism.

These challenges and problems are amplified in the developing world context. There are specific smart city challenges in developing world countries: the lack of infrastructure, the rapid development necessity due to the threat of disasters, urban sprawl, mass migration etc., less democratically oriented governance, limited number of monitoring and watchdog organizations, low education levels, weak legislations, disempowerment of citizens. All of these factors hinder the prioritization of public participation in city-making and management processes. This study aims to discuss the possible opportunities and advantages provided by ICT in the context of one of the developing countries, Turkey. In this context, we address the existing urban transformation practices with its critical situations within the scope of citizen participation in the following section.

3. Urban Transformation Practices in Turkey

Turkey is located on between East Anatolian and North Anatolian Fault Zone and so it has exposed many earthquake throughout its history. Moreover, there are many disaster types such as floods, landslides, storms have damaged urban areas and more than 90,000 people have lost their lives and 8,7 million people have directly affected from these disasters (Table 1) (EM-DAT, 2019).

TABLE 1. Disaster profile of Turkey (1900–2019) (based on EM-DAT).

Disaster type	Events count	Total deaths	Total affected	Total damage ('000 US\$)
Earthquake	78	89236	6924689	24685400
Flood	71	1359	1785020	2195500
Landslide	13	463	13587	26000
Mass movement (dry)	1	261	1069	0
Storm	10	98	13909	602200
Wildfire	5	15	1150	0
Total	178	91432	8739424	27509100

In 2012, The Government of Turkey has enacted the Disaster Law, which titled officially as The Law Regarding the Transformation of Areas, to identify the set of rules and procedures regarding to the rehabilitation and

TECHNOLOGY-DRIVEN PARTICIPATORY SPATIAL DESIGN IN A DEVELOPING WORLD CONTEXT: THE CASE OF ISTANBUL

renovation of urban areas and buildings that are under disaster risks (Official Gazette 2012). In this context, The Ministry of Environment and Urbanisation, which is a main responsible authority in urban transformation process, announced that nearly 6,7 million housing units are under disaster risks and they have a plan to transform 1,5 million of them in next five years within the scope of urban transformation (Şenses Kurukiz, 2019). Since the time when the law was enacted (2012), the governmental authorities have attempted to renew numerous urban areas. However, this process have not been conducted as planned due to the several complexities. Urban transformation practices in Turkey have been criticized by many stakeholders from the perspective of citizen participation. First of all, Disaster Law offered only one participatory activity that enable citizens to negotiate with the responsible authorities, which is limited to one-sided information exchange rather than active involvement of participants in planning and design process. Other criticisms towards urban transformation process in Turkey are listed as following:

- Implementation of top-down policies: Citizens are exposed to urban transformation approaches that based on top-down decision making processes and reactional movements conducted by civil society are eliminated (Eliçin, 2014)
- Lack of open data and collaboration: Central government don't tend to make collaboration with universities and public and it is unwilling to make the required data open and share with public (Balaban, 2019).
- Minimization of experts' role: Legal process minimizes the role of experts and eliminates the citizen and expert participation in project development process (Tansel, 2019).
- Failing to consider the existing local social and cultural context: Urban transformation projects are developed by ignoring the real needs, cultural backgrounds and space usage habits of citizens so the ties between accommodation and social life is broken (Adanali, 2014; Bora, 2013).

In reaction to these serious problems, many petitions and protests have been organized by neighbourhood associations through social media and these actions aim to cope with the top-down urban transformation practices imposed by central government (Figure 1). Moreover, these actors bring lawsuits against the designation of their living areas as disaster area. Thus, many decisions pertaining to risky areas have been cancelled.



Figure 1. A demonstration against an urban transformation project in Istanbul (Url-1).

4. Pilot study: Testing Mobile Participation APPs in a Real-world Case in Istanbul

This research is a part of a PhD project through which we developed an ICT-based participatory design model by considering the weaknesses and strength points of Turkey's current urban transformation practices in terms of citizen participation (Gün, 2019). This model not only proposed several participatory design actions that can be used in the process but also introduce the principles behind the model, identify the interaction environments that can be employed to realize proposed actions and address the evaluative criteria for examining the success of urban transformation practices. In this study, we present the results of the findings of two pilot studies that aim to collect the idea of citizens and experts regarding the planning and design of one of the urban transformation area, Süleymaniye.

4.1 THE ELEMENTS OF MOBILE PARTICIPATION APPS

As this study focus on the philosophy of social construction of data and information, we haven't preferred to use any computational algorithm. In the proposed model, it is adopted the data-driven process to reduce the political effects on decision making and make urban design processes more objective and neutral. To do so, in this study, we propose a data action flow for data collection process. To conduct the participation activities, it is proposed to involve a stakeholder group which called as participation architect. A participation architect can be a single person or a group that consists of members with different backgrounds and it is responsible for mediating and facilitating the process. In this scenario, firstly, the requirements for data collection process and the features of thematic mobile participation apps are addressed with the collaboration of participation architect and social workers (students in this case) who already knew the situation about related urban

TECHNOLOGY-DRIVEN PARTICIPATORY SPATIAL DESIGN IN A DEVELOPING WORLD CONTEXT: THE CASE OF ISTANBUL

transformation areas. Then, data collection process is carried out and all of this data can be monitored by the organizer. After that the collected data can be filtered and classified by categories on editor interface and this data can be exported as various format, e.g. .shp, .kml, .mif, .csv. To customize the app interfaces and monitor and edit the collected data, we use GIS Cloud software components. Exported data is visualized through the use of data visualization software in order to make collected data understandable. Finally, visualized data shared with related actors to discuss findings and determine inputs for project development process (Figure 2).

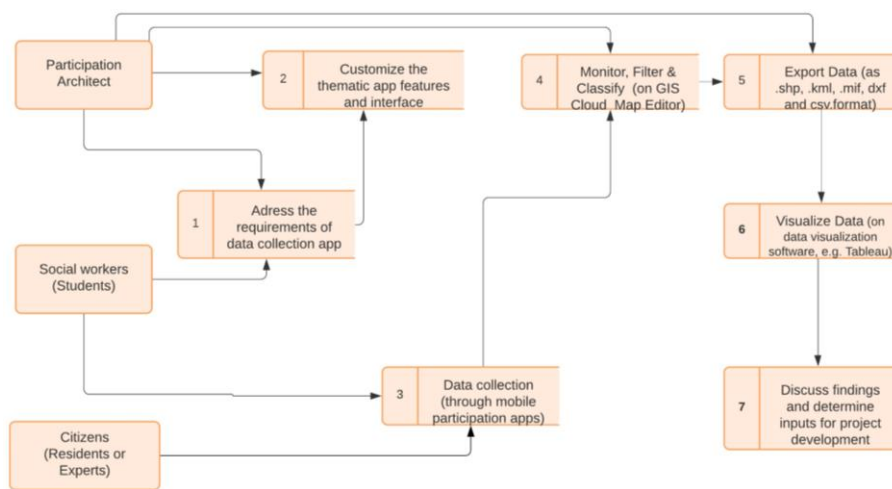

Figure 2. The involved actors and data workflow of the process.

In the first stage of the pilot study, groups of three students were assigned the task of making communication with the current inhabitants of the area and the students asked them to express their needs, desires, and expectations concerning the transformation of their neighborhoods. In this sense, students were able to add geo-located annotation, draw polyline that show boundaries of related area, record voice and take photos through the use of “İhtiyaçlar_Süleymaniye” (Needs_Süleymaniye) and “Hayaller_Süleymaniye” (Desires_Süleymaniye) applications (Figure 3).

During this workshop, the inhabitants were firstly asked to identify a location name and define the boundaries of area regarding their needs or desires as a polyline on map and then they were asked to make statements about their needs, desires and expectations. Several inhabitants preferred to use these apps and add data by their own (Figure 4).

In the proposed model scenario, we not only involve inhabitants in UTP, but we also propose the involvement of citizens who cannot take official role in the process but gain expertise on several domains and have ideas pertaining to related urban areas (Gün, Pak and Demir, 2020). This

participation approach can be conceptualized as expertsourcing. As the quality and content of the proposal of these people is considered different from the residents' input so these ideas should be involved through different channels into the process.

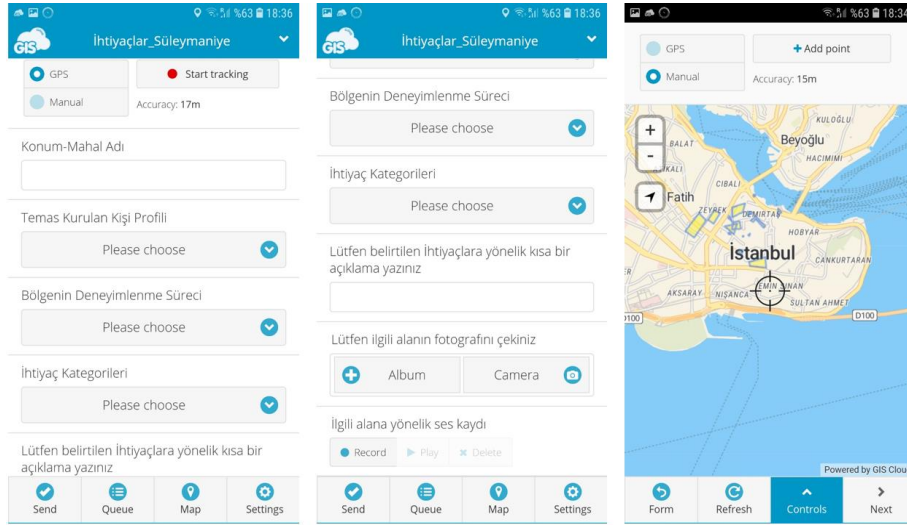

Figure 3. The user interface of “İhtiyaçlar_Süleymaniye” application.



Figure 4. Data collection process.

Thus, in the second pilot study, we got in touch with eight experts from professional domains, such as art historian, sociologist, urban planner, architect, who have already carried out several studies about Süleymaniye and collect their ideas and proposals regarding the transformation of the area. In this sense, we firstly carried out semi-structured interviews with

TECHNOLOGY-DRIVEN PARTICIPATORY SPATIAL DESIGN IN A DEVELOPING WORLD CONTEXT: THE CASE OF ISTANBUL

these experts and then transferred these data to the “Uzman Grup Öneriler” (Expert Group Proposals) mobile application which enable to input geo-located data (Figure 5).

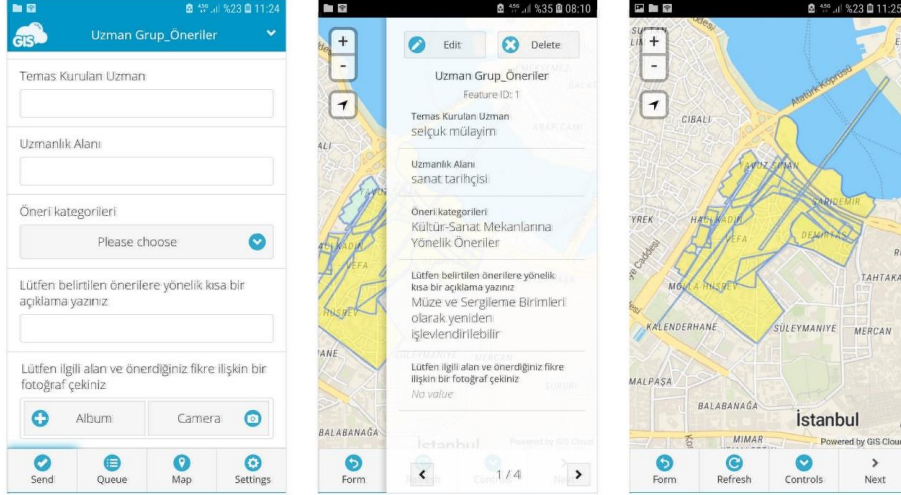
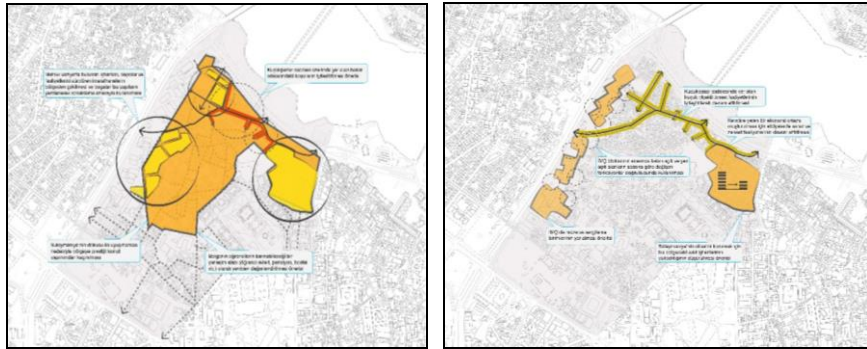

Figure 5. The interfaces of “Uzman Grup Öneriler” app.

At the end of this pilot study, we were able to collect proposals from experts for the rehabilitation projects at different categories as “Proposals concerning Süleymaniye in general”, “Proposals about intervention approaches”, “Proposals regarding accommodation units”, “Proposals about recreation areas”, “Proposals about commercial activities”, and “Proposals concerning transportation and accessibility”. Afterwards, all of collected data was visualized and used to create thematic proposal maps (Figure 6). In the final steps of the study, we have made questionnaire with the participants in order to collect feedback, their ideas and proposals regarding pilot study and tested apps.



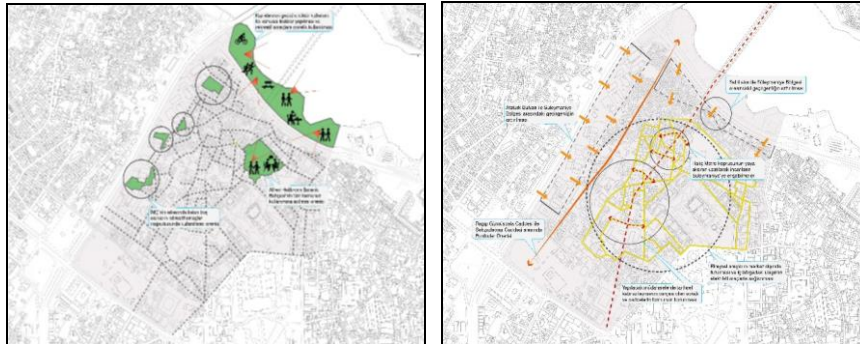

Figure 6. The thematic synthesis maps based on the expert proposals for the Suleymaniye Neighborhood in Istanbul, demonstrating how expertsourced data and information can be translated into urban design and planning strategies.

4.2 PRELIMINARY RESULTS & RESULTS OF THE EVALUATION (POSITIVE ASPECTS & CRITIQUES)

Based on the questionnaires conducted with workshop participants, obtained data from two pilot studies and our observations, this subsection critically discusses the key findings relevant to the pilot study.

Advantages and limitations of the use of mobile applications for crowdsourcing and expertsourcing: The use of mobile applications enables to collect a huge amount of data in short time and keep all data in digital database and this data can be accessed by all interest groups. This eliminates the problems of traditional techniques about the processing and visualization of collected data and enable to share data with stakeholders in an open and transparent way. Moreover, all data can be filtered and categorized easily and this data can be analyzed by using statistical methods so it is possible to get meaningful data to use in urban development projects. On the other hand, workshop participants noted that they witnessed several difficulties while drawing the boundaries of the area because inhabitants could not define the area where they expressed their desires and needs for. Moreover, they stated that they faced several problems about the use of the applications due to the use of academic language on the application interface. Furthermore, students reported that many inhabitants tend to express their needs orally rather than giving location based feedback and they didn't use predefined categories of the applications.

Obtained data: After the two pilot study, we evaluated the collected data and examined it in terms of quality and usability. In the first workshop, the neighborhoods inhabitants only expressed their needs vaguely and they didn't notify any desires and expectations concerning the transformation of their neighbourhoods. They specified their basic accommodation needs and necessities rather than express design ideas for the future transformation of the area. Some of the inhabitants only stated that they don't want to move

TECHNOLOGY-DRIVEN PARTICIPATORY SPATIAL DESIGN IN A DEVELOPING WORLD CONTEXT: THE CASE OF ISTANBUL

from this neighbourhood whereas other inhabitants hesitated to answer several questions for fear that their shared data will possibly be monitored and used for surveillance by some decision-makers. Other groups of inhabitants complained about the existing urban transformation practices and told stories about the historical situation of the area. They also mentioned the tiring nature of long-term transformation speculations and how they lost their hopes for the future.

As a result of this pilot study, it became clear that inhabitants are not used to “having their say” and do not have enough experience on getting meaningfully involve in participation actions partially due to the lack of culture of democracy in Turkey and partially due to lack of education. Another relevant observation was the lack of trust in the participation process, and disbelief in the inclusion of their feedback in the urban transformation process. From a critical point of view, our study was one of the many participatory design actions which did not result in direct impact on the inhabitants’ lives and the UTP in Suleymaniye since we aimed at developing and testing a participatory design model. These experiences showed us that the participation efforts will be limited to “therapy sessions” as Arnstein mentions, unless required legal steps are taken towards public participation and decision makers assure that the inhabitants’ notifications, feedback and ideas will be used or integrated into design processes.

On the other hand, in the second workshop, we were able test expertsourcing approach with the use of mobile apps. Even though the limited number of participants (8 experts) attended this study, it was possible to collect high quality design input concerning the transformation area and we were able to map these ideas by using different categories such as intervention approaches, accommodation units, accessibility, recreation areas etc. The quality and scope of the collected data from experts revealed that expertsourcing approach should be considered as a key potential participation method and it should be considered as potential method to address the challenges in the urban transformation processes taking place in Turkey.

5. Conclusions

Developing countries face acute urban challenges including: natural disasters, basic infrastructure needs, urban sprawl, mass migration, and so on. Moreover, multifactor poverty, low education levels of the community, less democratically oriented governance, the lack of legislation framework that facilitate bottom-up actions are the other setbacks of the developing world context. All of these factors have caused to the prioritization of rapid urban transformation processes that focus just on providing the basic needs and necessities of the public.

In this paper, we concentrated on the use of mobile participation application in one of the urban transformation area located in Turkey with the involvement of inhabitants and experts. On the one hand, the use of this technology-driven participatory design methods facilitate to carry out participation actors in terms of many aspects. It can foster wider participation of citizens by lowering time and space barriers (Gün, Pak and Demir, 2020), facilitate to process the collected data in an objective manner and share it with stakeholders in a transparent way. On the other hand, the design and appropriation of these apps turn out several challenges for process designers. The issues involved questions as following: how can participants be motivated to involve in design process? How can decision makers use the results of the collected data? And, most importantly, what are the components of the urban collaboration ecosystems that suit to social and cultural context and planned objectives.

Specific to the tested applications, we can summarize the observed problems: (1) the unwillingness and hesitations of the inhabitants to express their expectations and desires with respect to the design of their neighborhood due to the fears and the losing of hopes and sense of belonging, (2) the lack of participation cultures of the residents that hinder them to envision the future transformation of their living area, (3) the low socio-economic situations of them that cause to prioritize basic needs and necessities, (4) the lack of collaboration environment that assure them to integrate their ideas and proposals into the urban development process.

This conjuncture that can be seen at first sight makes participation look irrelevant. Participation should be thought beyond the citizen involvement but multi-stakeholder inclusion, particularly aim at bridging between the civil society, governmental organizations, academy and building industry. A fortiori than simply copying participation ecosystems that are created in developed countries, it is essential to create a custom one that is locally relevant that can be adapted and addressed these complicated challenges and problems. This urban collaboration ecosystem (Figure 7) should be designed to go beyond human actors, and should consist of several components such as technologies, approaches, values, atmosphere, collaboration protocols and actions, actors, inclusion strategies.

Based on the literature review and the pilot tests discussed, we conclude with several key principles as a future direction for establishing a multistakeholder participatory urban collaboration ecosystem (UCE):

- The adoption of ICT and data-driven culture to blend information across all different domains, areas, and actors and facilitate transparent process by increasing the testimony of public.
- The involvement of social and cultural values of the inhabitants. For instance, in Turkey, everyday communication culture is based on orally. Thus, the communication channels and methods should be rethought by using this reality.

TECHNOLOGY-DRIVEN PARTICIPATORY SPATIAL DESIGN IN A DEVELOPING WORLD CONTEXT: THE CASE OF ISTANBUL

- Regulating the knowledge, information and data produced through the urban collaboration ecosystem (UCE) as a commons.
- The designation and use of clearly defined protocols to identify the rules regarding who has the right to access knowledge, information and data collectively produced as a commons, how knowledge commons are generated and preserved, and how they are managed and governed (Hess and Ostrom 2007, p. 9).

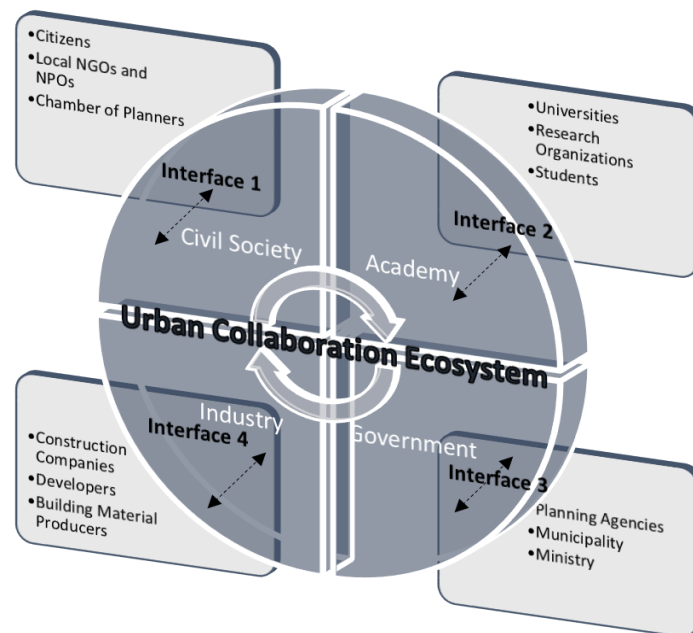

Figure 7. Participation beyond citizen engagement to address the challenges of the developing world context: a proposal for an urban collaboration ecosystem (UCE) for Turkey

- Moreover, setting protocols to specify a basis for protecting participants' private information and shared data without being subjected to surveillance.
- Before the collaboration and participation processes, identification of clear protocols on how the knowledge, information, data generated will be included in urban design, planning and transformation, empowering the participants to track the ways in which their feedback is considered and accountability.
- Citizen groups in Turkey tend to trust in urban activist groups and university organizations and they are willing to collaborate with these actors (Yalçintan, 2009). In this sense, paying utmost attention to enable the involvement of these groups motivate inhabitants to participate in design process and reestablish trust.

- The appropriation of expertsourcing approach via social networking platforms where citizens who gain expertise on several domains and have ideas and proposals regarding the design and planning of the area can collaborate. Developing this ecosystems enables to uncover individual ideas of all parts of the community, allows joint learning across a wide range of stakeholders, facilitate experience and knowledge transfer between participants and foster the others to share proposals.
- Custom empowering and enabling technologies and interfaces to ensure the different needs and profiles of the collaborators of the urban collaboration ecosystem (UCE) (Figure 8), technologies for the engagement of the civil society, governmental organizations, academy and building industry.

Acknowledgements

This paper reports findings from a PhD research project supported by the Türkiye Bilimsel ve Teknolojik Araştırma Kurumu [TUBITAK] under grant number 1059B141700622 titled “An ICT-Based Participatory Design Model for the Urban Renewal Areas in Turkey”.

References

- ADANALI, Y. (2013). Urban Transformation and Law on Disaster Prevention: A Pretext for Lucrative Investment, Perspective. *Political Analysis and Commentary from Turkey*, 3, 37-39.
- ANGELIDOU, M. (2014). Smart city policies: A spatial approach. *Cities*, 41, S3-S11.
- BAKICI, T., ALMIRALL, E., AND WAREHAM, J. (2013). A smart city initiative: the case of Barcelona. *Journal of the knowledge economy*, 4(2), 135-148.
- BALABAN, M. Ş. (2019). Hazard-Prone Cities and Recent Challenges in the Case of Urban Transformation Experience of Turkey. In *Urban and Regional Planning in Turkey* (pp. 235-259). Springer, Cham.
- BORA, T. (2013). Sunuş yazısı, Milyonluk Manzara, 7-10
- CAPDEVILA, I., AND ZARLENGA, M. (2015). Smart city or smart citizens? The Barcelona case. *The Barcelona Case* (March 26, 2015).
- DAMERI, R. P. (2013). Searching for smart city definition: a comprehensive proposal. *International Journal of computers & technology*, 11(5), 2544-2551.
- ELICIN, Y. (2014). Neoliberal transformation of the Turkish city through the Urban Transformation Act. *Habitat International*, 41, 150-155.
- FINLAND MINISTRY OF ENVIRONMENT (1999). Land Use and Building Act. < <https://www.finlex.fi/en/laki/kaannokset/1999/en19990132.pdf> >, alındığı tarih: 08.09.2019.
- GEROPANTA, V. (2020). The Smart City in Relation to Its Environment, Perception, and Urban Planning Process: Lessons for Developing Countries. In *Perception, Design and Ecology of the Built Environment* (pp. 547-561). Springer, Cham.

TECHNOLOGY-DRIVEN PARTICIPATORY SPATIAL DESIGN IN A DEVELOPING WORLD CONTEXT: THE CASE OF ISTANBUL

- GIFFINGER, R. et al., 2007. Smart Cities - Ranking of European medium-sized cities. Vienna University of Technology. Available at: http://research.ku.dk/search/?pure=files%2F37640170%2Fsmart_cities_final_report.pdf [Accessed May 13, 2015].
- GÜN, A. (2019). Türkiye'deki Kentsel Dönüşüm Alanlarına Yönelik Bilişim Teknolojilerine Dayalı Katılımcı Tasarım Modeli Önerisi (An Ict-Based Participatory Design Model For The Urban Renewal Areas In Turkey), PhD Thesis, The Institute of Science and Technology, Istanbul Technical University, Turkey.
- GÜN, A., DEMİR, Y., & PAK, B. (2020). Urban design empowerment through ICT-based platforms in Europe. *International journal of urban sciences*, 24(2), 189-215.
- GÜN, A., PAK, B., & DEMİR, Y. (2020). Responding to the urban transformation challenges in Turkey: a participatory design model for Istanbul. *International Journal of Urban Sustainable Development*, 1-24.
- HESS, C., AND OSTROM, E. (2007). Introduction: An overview of the knowledge commons. *Understanding knowledge as a commons*, 3-26.
- KITCHIN, R. (2014). The real-time city? Big data and smart urbanism. *GeoJournal*, 79(1), 1-14.
- NAM, T., AND PARDO, T. A. (2011, June). Conceptualizing smart city with dimensions of technology, people, and institutions. In *Proceedings of the 12th annual international digital government research conference: digital government innovation in challenging times* (pp. 282-291).
- NEIROTTI, P., DE MARCO, A., CAGLIANO, A. C., MANGANO, G., AND SCORRANO, F. (2014). Current trends in Smart City initiatives: Some stylised facts. *Cities*, 38, 25-36.
- OFFICIAL GAZETTE (2012). Afet riski altındaki alanların dönüştürülmesine ilişkin kanun (The law regarding transformation of areas under disaster risks). Retrieved from <http://www.resmigazete.gov.tr/eskiler/2012/05/20120531-1.htm>
- ŞENSES-KURUKIZ, 2019. The transformation of 1,5 million housing units will be completed in five years. Available at: <https://www.aa.com.tr/tr/turkiye/cevre-ve-sehircilik-bakani-kurum-1-5-milyon-konutun-donusumu-5-yil-icerisinde-yapilacak/1579712>
- TANSEL, C. B. (2019). Reproducing authoritarian neoliberalism in Turkey: Urban governance and state restructuring in the shadow of executive centralization. *Globalizations*, 16(3), 320-335.
- THE EMERGENCY EVENTS DATABASE - EM-DAT (2019). Disaster profile of Turkey between 1900-2019. Retrieved from www.emdat.be.
- UNECE (1998). Convention on access to information, public participation in decision-making and access to justice in environmental matters, < <https://www.unece.org/fileadmin/DAM/env/pp/documents/cep43e.pdf> >, alındığı tarih: 08.09.2019.
- URL-1: <<http://haber.sol.org.tr/toplum/sariyer-derbent-mahallesine-secim-oncesi-yeni-imar-plani-257533>>, [Accessed: August 5, 2019].
- YALÇINTAN MC (2009). Kentsel Muhalefetin Halleri ve Halsizlikleri [The conditions and weaknesses of urban opposition]. <http://www.planlama.org/index.php/planlamaorgyazlar6/planlamaorg-yazlar/57-planlamaorg-yazlar/murat-cemalyalcintan/489-kentsel-muhalefetin-halleri-ve-halsizlikleri>.

MATERIALITY: LINKING A DIGITAL MATERIAL FRAMEWORK WITH THE ANTHROPOLOGICAL HAND

MARYAM HOUDA

University of Sydney, Australia

148 City Road

Darlington, NSW 2008, Australia

Email address: maryam.houda@sydney.edu.au

Abstract. While computers and digital technology have evolved over the years and are changing the way we design and construct, some have criticized the way in which human tactility and intuition with material has diminished at the cost of increasing productivity and efficiency. Although the digital culture that architecture is engaged with today has brought about complex forms that could not have been possible by hand, there is a rising question of the place of craft and a hand-brain coordination in design, and the notion of learning through making. This paper explores the benefits and limitations of digital design tools in light of physically exploring building materials and gaining tactile intuition. While digital tools investigate structural optimisation methods using a parametric design workflow, physical experiments deal with understanding the transitional state of mud and its dynamic properties. This research is interested in how information is learnt from materiality during the physical act of making and what tactile experimentation can offer that the digital space cannot. Three key areas are explored: geometry and parametric variation, material properties and morphogenic behavior, as well as structural optimization methods using density grids. Force-matter relations are investigated through exploring material parameters through digital and physical form-finding processes as a way of exploring the notion of re-introducing the hand and craft in the design process which may bring about novel ways of thinking and doing.

Keywords: *Materiality, Tactility, Digital Workflow, Morphogenesis, Structural Optimization*

ملخص. بينما تطورت أجهزة الكمبيوتر والتكنولوجيا الرقمية على مر السنين وغيرت طرق التصميم و البناء ، فقد انتقد البعض الطريقة التي تقلصت بها اللمس البشري والحدس مع المواد على حساب زيادة الإنتاجية والكفاءة. على الرغم من أن الثقافة الرقمية التي تعمل بها

MATERIALITY: LINKING A DIGITAL MATERIAL FRAMEWORK WITH THE ANTHROPOLOGICAL HAND

الهندسة المعمارية اليوم قد أحدثت أشكالاً معقدة لم تكن ممكنة يدوياً ، إلا أن هناك سؤالا متزايدا حول مكان المهارة والتنسيق بين اليد والدماغ في التصميم ، وفكرة التعلم من خلال صنع . يكشف هذا البحث فوائد أدوات التصميم الرقمية والقيود الذي يواجهها في ضوء استكشاف مواد البناء فعلياً واكتساب الحدس باللمس. بينما تبحث الأدوات الرقمية في طرق التحسين الهيكلي باستخدام التصميم البارامتري ، فإن التجارب المادية تتعامل مع فهم الحالة الانتقالية للطين وخصائصه الديناميكية. يهتم هذا البحث بكيفية التعلم و الاستفادة من المعلومات أثناء الصنع المادي وما يمكن أن تقدمه التجربة اللمسية ولا يمكن للمساحة الرقمية أن تقدمه. هذا البحث استكشف ثلاث مجالات رئيسية: الهندسة والاختلاف البارامتري ، وخصائص المواد والسلوك المكون. هذا بالإضافة إلى طرق التحسين الهيكلي باستخدام شبكات الكثافة. هذا البحث يحقق في العلاقات بين القوة والمادة من خلال استكشاف المواد البارامتريه. وهذا من خلال عمليات البحث عن الشكل الرقمي والمادي كطريقة لاستكشاف فكرة إعادة إدخال اليد والحرف في عملية التصميم والتي قد تؤدي إلى طرق جديدة للتفكير والقيام.

الكلمات المفتاحية: العمل الرقمي ، المادية ، التشكل ، التحسين الهيكلي

1. Background

The research aims to reflect the dynamic nature of architecture by focusing on materiality by linking a digital material framework with the anthropological hand. Morphogenesis is a term used to describe the structural evolution of natural organisms typically used in development biology, emergence models as well as material systems (Oxman and Oxman, 2014). This research uses the term to reflect on the transitional state of mud as passive matter to activated form through the making process. The research relates to morphogenesis in the analogue and digital world, where through direct contact with the material, the human as the intellectual agent can morph and shape mud due to its emergent material behavior once in contact with our hands as the tool, as well the presence of water which releases stored energy in matter, and the environmental context working as external forces/stimuli.

The research also adopts a digital material framework that investigates performance-based design, exploring adaptive organizational strategies to optimize straw density. Here the digital framework reflects morphogenesis by using digital tools as a systematic method of abstracting information to bring about variations and transformation in form. It must be noted that this research does not perceive shape as a final form but rather the result of a transitional and evolving process, where the form we perceive has embedded information in terms of organizational strategies, the material parameters that affect the physical and chemical process such as muds elasticity and variability, as well as reflecting on how the environmental conditions such as temperature and humidity can have an effect on the perceived form, all in which work together to allow for the materials self organization.

Furthermore, the anthropological hand or the hand, is the term used to describe the process of acquiring knowledge without formal education on the 'know how's' or 'to do's' but rather through intuition. It is understood as a way of sensing knowledge through touch or tactility and a response to the materials essence, as a negation between matter, the hand and the environmental forces that surround us.

1.1. FROM STATIC TO ADAPTIVE GRIDS

Reflecting on the morphogenic nature of the material, the practical experimentation of this research develops from static grid organizational strategies to adaptive grids, where the region of a body is tessellated based on natural force flows due to the placement of applied load points. Through experimenting with mud as brick sized masonry units and a hypothetical wall structure, this research investigates various ways for the organization of matter at a micro and macro scale using multi-scalar density grid templates that vary in opening shape and size to optimize structure. The compressive and tensile material performance is digitally analyzed using Finite Element Analysis (FEA) as a visual method to understand force flow at a discrete and continuous scale using points or nodes, so that the density of straw reinforcement in mud can be varied accordingly at different intervals.

2. Computational Material Framework

2.1. FINITE ELEMENT ANALYSIS (FEA)

The paper explores organizational adaptive grid patterns as a response to the forces of displacement internally and externally (gravity, pressure, etc.). If a point moves, which represents a load, then essentially the grid also adapts and moves. A novel FEA-centralized framework visualizes and represents the dynamic behavior of matter and solves issues in terms of dynamic stresses and geometric deformation and displacement. FEA is a numerical approach using simultaneous algebraic equations to solve mathematical physics and engineering problems such as structural analysis, fluid flow and heat transfer to name a few. This paper utilizes FEA to simulate and visualize the structural analysis of mud bodies as well as acting as templates for a various fiber density, according to stress regions within each discrete region. A digital numerical method is appropriate for complex geometries, as the body is divided into subsystems or discrete unit regions and is either connected at specific points where two elements come together to create nodes, or at boundary lines or surfaces to create discretization (Logan, 2012).

MATERIALITY: LINKING A DIGITAL MATERIAL FRAMEWORK WITH THE ANTHROPOLOGICAL HAND

Using FEA, the problem is not solved as one equation for the body as a whole; rather equations are produced for each element or unit, and then joined to find a solution for the body. The extent and purpose that FEA will be used in this research paper is to calculate the displacement at each node of the body due to an external force, and to determine the internal stresses of each element because of an applied load to a continuous solid. The research incorporates the principles of Strut and Tie Modelling (STM), to understand compressive and tensile regions as simplified triangulated truss models.

2.2. STRUT AND TIE MODELLING (STM)

Typically, STM models use single truss elements to reinforce and hold the object in tension. However, this research produces a novel approach combining the basic principles of STM with FEA to strategically organize and reinforce mud bodies with multiple chopped fiber to perform like single truss elements. Currently little literature exists around STM modelling for mud, however, because concrete moulds and solidifies just like mud, we can compare the materials due to their similar transitional behavior. Compressive forces are understood as struts and tensile forces are translated as ties. Here, the research uses STM to the extent of dividing the body into ‘B’ and ‘D’ regions as seen in Figures 1 and 2.

2.2.1. *Bernoulli’s principle and St Venant’s principle: ‘B’ (Bending) and ‘D’ (Discontinuity) regions*

In any structural form, strut and tie members are distributed in regions called ‘B’ and ‘D’ regions. B-regions are bending regions and follow the Beam Theory based on Bernoulli’s assumptions and only apply to lateral loads where the distribution of strain is linear (El-Metwally and Chen, 2017). D-regions are regions of discontinuity or disturbances, and follow St Venant’s principle, where “The localized effect of disturbance dies out by one-member depth from the point of disturbance” (Wight and MacGregor, 2009). Thus, unlike B-regions, the plane sections of D-regions do not stay planar after bending. Regions that can be classified as D-regions include geometric discontinuity, regions adjacent to openings, regions with changes in cross-section or direction, or a statical discontinuity which are regions where the load is being applied or where there are reacting supports (Wight and MacGregor, 2009). Because this research aims to achieve continuity in form, the principles of STM coupled with FEA will be an efficient method in re-designing structures that may include ‘D-regions’ so that they perform as one component or one building block.

From a technical perspective, the research discussed in this paper aims to control and vary fiber density and arrangement using grid templates to

structurally optimize discrete units of reinforced mud mixtures. The process aims to reflect the ability of mud as matter to perform at both a discrete and continuous system that evenly transfers and distributes the flow of forces. The novel framework 1.0.A developed for the mud block experiment, as seen in Figures 1 and 2, to control fiber placement and density, initially utilized tensile force flow lines produced from the FEA to densify the stress into discrete boundary units as a way of producing a two-dimensional density grid.

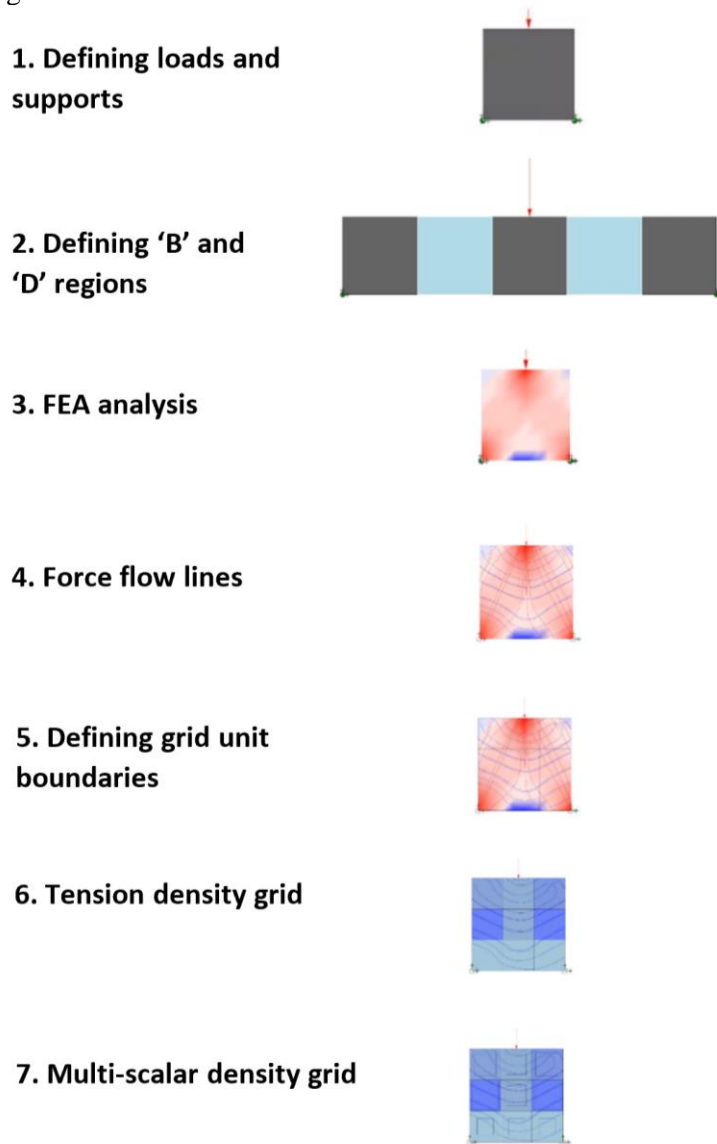

Figure 1. Novel FEA/STM (single unit)

MATERIALITY: LINKING A DIGITAL MATERIAL FRAMEWORK WITH THE ANTHROPOLOGICAL HAND

Figure 2 shows how different grid patterns can be used and the future implementation of using algorithmic optimization methods. The greater amount of force flow lines in each discrete boundary, the greater the stress present, highlighted in the darker shade of blue and thus the more straw added to accommodate for tensile strength. Therefore, the grid explores a visual and color-coded organizational strategy in accordance with stress fields.

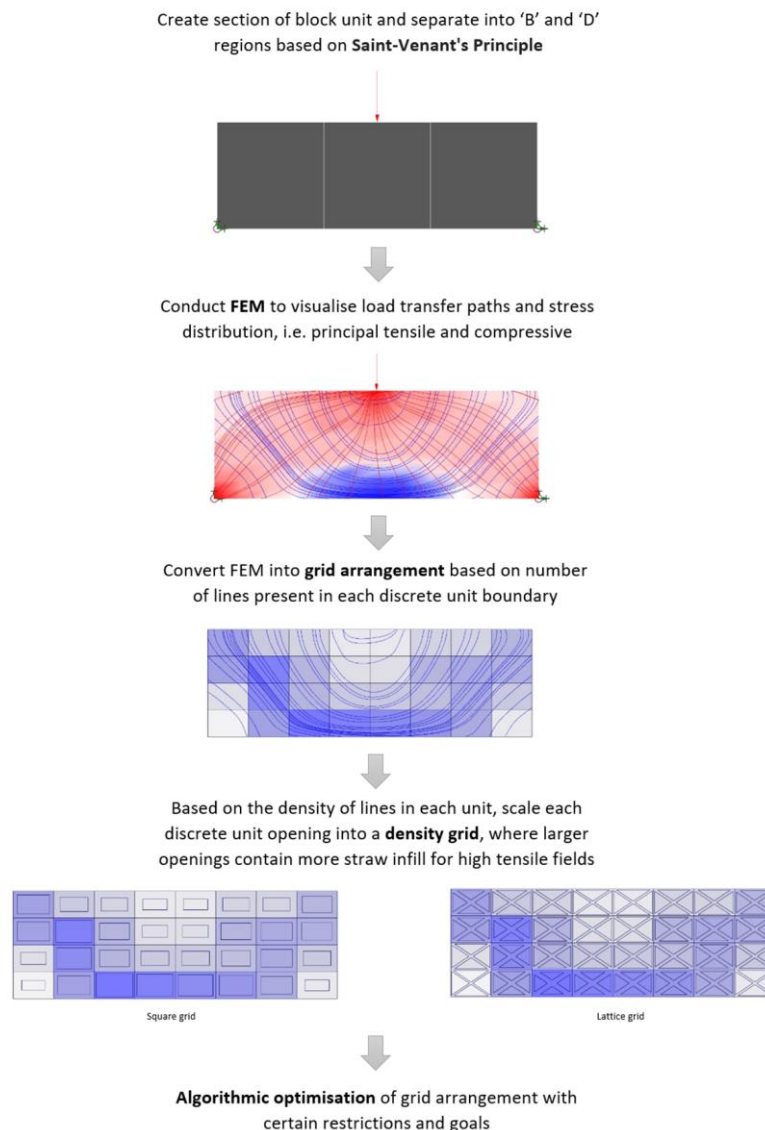

Figure 2. Digital Framework 1.0.A (square and lattice grid)

3. Mud block experiment: Square density grid at a micro scale

A soil sample was collected from a nearby site during excavation in the Sydney CBD, which was identified as sandy loam after a 24-hour sedimentation test. Air dried terracotta clay was added to the soil sample to increase the clay percentage from 8.75% to 20%, making it a clay sandy loam, more suitable for mud bricks. Because the soil sample had a large sand percentage, 20% clay instead of 25% was used to reduce the chances of cracking. For this experiment, 150x150x150 mud block samples were casted using the excavated soil sample. As shown in Figure 3, the sample was sieved to remove larger stones, mainly sandstone. Four mud blocks were casted, with mud block A being the control. A standard mud brick ratio consisting of 6 parts soil to two parts straw to two parts water was used. To make the four mud blocks, an initial 7.035L of soil mix was used. Added to the soil mix was 1.365L of air-dried terracotta clay as well as 2.8L of water and an initial 25 grams of straw. Because straw absorbs water, an extra 0.2L of water was added, totaling to 3L of water.



Figure 3. Soil sample sieved to remove large stones.

Terracotta clay was added to the sieved soil sample mix, as seen in Figure 4, cut at thumb size, and continuously mixed in the dry soil sample to ensure the clay was evenly distributed. Water was slowly added as well as a handful of straw at a time until the right consistency was achieved. It must be noted that the hand was the main tool used here to ‘measure’ during the making process and proved easier to get a ‘feel’ of the consistency of the material rather than the shovel. The straw length varied from 0.8mm to 7mm. The aim was for the mix to not be too wet where it runs off the hand or utensil, but also not too sticky that it holds to the utensil/hand. Rather the mix should be able to hold itself and run off simultaneously (Edwards, 1990). When the last 0.2L of water was added to the mix, the mixture felt too runny. To correct this, 670 grams of sieved soil was added and 5 grams of straw. After 30 minutes of continuous manual mixing, as seen in Figure 5, the mud sample was ready to be casted.

MATERIALITY: LINKING A DIGITAL MATERIAL FRAMEWORK WITH THE ANTHROPOLOGICAL HAND



Figure 4. Terracotta clay added to soil sample.



Figure 5. (left): water added to dry mix; (middle): varied straw length; (right): hand mixing.



Figure 6. (left): Filling and poking the mud mixture into the mould for mud block A (control); (middle): removing the filled mould; (right): mixture slumping, not holding form.

For the first cast which was the control, the mixture was scooped and filled a handful at a time into the mould, which was wetted before filling for a smoother removal. To remove any air gaps, the mud mixture was poked and massaged making sure it filled to the edges. After removing the mould, it appeared that the mix did not hold and slumped, which was an indication that the mix was too wet. An additional 600 grams of soil was added and 5 grams of straw totaling to 7.6035L of soil mix and 30 grams of straw. A stickier consistency was achieved however the mix slumped again. A

hypothesis based on observation was made during the making process, that the size of the mud block was not appropriate for the material, because the feel of the material was appropriate for casting. Thus, the mould was filled halfway with 4 handfuls instead of 8. As seen in Figure 7, the mud was able to take form at half the height of the mould (75mm).

The back-and-forth information brought about by direct contact with the material was reflected in the preparation of the mud mixture, however lacked in the digital, where it was represented as a number, the young modulus. Another point to be made was that in the digital model, the straw was not a separate entity to the mud like a steel rod is in reinforced concrete models. The digital tool used for the structural simulation lacked the ability to simulate a composite model as the straw is not a continuous beam element but rather mixed within the mud itself and is variously orientated. By engaging with the material, it became evident that FEA removed the essence of the material from the form-finding process. The material properties are simplified and represented numerically such as the young modulus representing the extent a material can stretch and deform, however the nature of mud is non-linear and dynamic while the young modulus is based on a linear stress-strain relationship. When using mud as a making material, it becomes apparent that no two mixes are ever the same just like how no two straws added to the mix are identical. Rather, the material demands the hand and tactility as a way of determining its readiness. Furthermore, while in the digital model the points are connected by lines and those lines are extruded to form surfaces, and the surfaces are used to create a mesh for FEA, when one comes to make the very same brick, we come to see that the material screams to be anything but rectilinear. It is impossible to replicate the precise and clean digital model with a material that is sticky and wet and is moulded and shaped with tools (our hands) which are round and curvy coupled with our nature to be imperfect and imprecise.



Figure 7. (left): Filling the mud mixture into the mould at only half the height of the mould; (middle): removing the filled mould; (right): the mixture holding form.

4. Results

4.1. THE MAKING PROCESS

Although the experiment did not go to plan, to make use of the remaining wet mud mix, the FEM square grid template which was designed to concentrate varied density of straw in a vertical placement, was used to place straw horizontally at half of the block height, that is between 2 handfuls of mud, and between each mud layer, essentially straw placement at one-third and two-thirds after each mud handful.

The first attempt (block B) using the square grid as seen in Figure 8, shows the challenge in regards to the straw fibers, as they were too long and did not successfully transfer through the square pockets, but rather remained on the top face of the grid template. In the second attempt (block C), the fibers were chopped into smaller pieces in Figure 9. The process was more successful in transferring the straw through the density pockets as seen in Figure 10. In Block D, the straw fiber layer was placed twice.



Figure 8. (left): Mud block B: square grid template at halfway (after 2 handfuls); (middle): removing the square grid template after placing straw; (right): the straw too long and not falling in the square pockets of the density grid.



Figure 9. (left): Mud block C: square grid template being placed halfway; (middle): varied square pockets of straw after template removal; (right): mud layer on top of straw placement.



Figure 10. (left): Mud block C: straw pocketing; (right): Mud block A- the control that has no straw density grid layer; Mud block B- 1 layer of the straw density grid using medium length fibers at 1/2; Mud block C- 1 layer of the straw density grid using short length fibers at 1/2; Mud block D- 2 layers of straw using short fibers at 1/3 and 2/3.

4.2. THE DRYING PROCESS

The mud blocks were left in the shade outside to dry due to Sydney’s unpredictable weather during January 2020. On the evening of day 1 of drying, the mud blocks were covered with a plastic sheet due to predicted night rainfall. On day 2, the blocks were still wet to touch and stayed under cover outdoors for 2 days. On the fourth day, the mud blocks were dry to touch on the top surface, but moist on the edges. Upon removing the mud blocks at 9am to dry in the sun, block A and B were difficult to remove from the pavement due to a suction-like effect. This indicated that the blocks had a higher moist content than block C and D which could easily be removed.

TABLE 1. Environment conditions during the first 5 days of drying the mud blocks.

	DAY 1 (29/01/2020)	DAY 2: (30/01/2020)	DAY 3: (31/01/2020)	DAY 4: (01/02/2020)	DAY 5: (2/02/2020)
9AM					
Temperature (°C)	24.5	23.5	26.5	28.9	25.7
Relative Humidity (%)	62	68	69	63	70
Wind Direction	S	W	NNE	E	S
Wind Speed (km/h)	17	7	4	13	13
3PM					
Temperature (°C)	26.7	28.5	30.5	34	28.6
Relative Humidity (%)	59	53	58	43	62
Wind Direction	SE	ENE	ENE	NE	SE
Wind Speed (km/h)	15	28	28	17	26

MATERIALITY: LINKING A DIGITAL MATERIAL FRAMEWORK WITH THE ANTHROPOLOGICAL HAND

It was also apparent that block A and B appeared to be larger in size. The blocks were turned on their sides so that the bottom surface could be exposed to air and sun to fully dry and harden. Environmental conditions were recorded during the first 5 days of the drying process as seen in Table 1 to investigate the effects of external forces. From the results, we can see that as the temperature increased, the humidity decreased. This was important so that the surface of the bricks did not dry out which would have led to the blocks cracking prematurely.

5. Discussion

The aim of this experiment was to cast a mud mixture into a 150x 150x150 mould. Essentially, this meant that although the density grid could be laid horizontally, because the mould was a cube, the mud block could be rotated so that the density arrangement could act in a vertical manner, as simulated from a top point load.

Because the cube mould was not an ideal size for casting mud, due to slumping because of the excessive height, the mould was filled halfway to make use of the large batch of mud mixture prepared. In Figure 11, attempt 3 reflects future work which will test a more standard brick size, where the length is double the height. Future work will also involve excluding straw from the entire mud mixture and only placing the tensile fiber through the density grid layers. Other grid patterns such as a lattice and U-V grid have been produced however, tests have not been conducted yet due to fibers unable to be filtered through the narrow grid openings unless chopped extremely fine. Development will also include the investigation of algorithmic optimization of the grid arrangement at a larger scale, with certain restrictions and goals and implementing reduction ratios in the digital material framework, so that the mud mixture is placed only where needed for efficient material use and minimal mass. Future ambitions of the research will also investigate using grid arrangements in the higher dimension so that the reinforcement layers are connected three-dimensionally.

Through engaging with the physical material, this research experiment was able to reflect the limitations of the digital world in representing the dynamic nature of mud. While this research is interested in the process of making, FEA simulations lack the potential of simulating the preparation of the matter to be actualized, for example, adding the water and straw slowly into the mud mix and getting a 'feel' of the materials readiness for use. The digital mode also lacked the ability to simulate the materials stickiness and the hands response to it in terms of shaping and moulding. We can 'make' a mud brick digitally using points, lines and surfaces, but in doing so we

remove the mud from the brick and so it becomes a geometry rather than about the ability to shape a material due to its transitional properties. Thus, the essence and morphological nature of the material is somewhat removed from the digital design process.

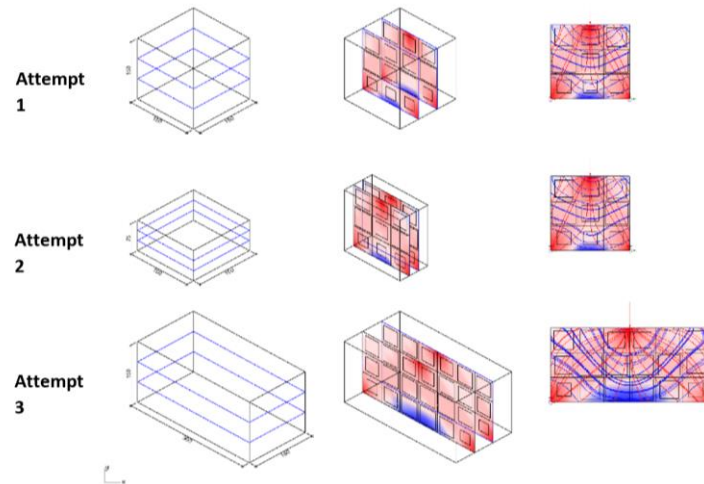

Figure 11. FEM simulation and novel STM process for mud blocks of different sizes and orientations.

While the digital material framework deals with discretizing and parameterizing the form to structurally optimize material performance, the analogue exploration dealt with a ‘learning by making’ approach, as a constructivist theory of learning, and acquiring material knowledge through making rather than focusing on a final form (Dewey, 1938). Thus, this research highlights that a balance is required between the digital and physical world in the process of design and making so that intuition and tactile information from the anthropological hand is not lost due to the rationalization of digital processes.

References

- DEWEY, J. (1938). *Experience and Education*. New York: Free Press.
- EDWARDS, R., 1990. *Mud brick techniques*. Kuranda: The Rams Skull Press.
- EI-METWALLY, S. AND CHEN, W., 2017. *Structural Concrete: Strut-And-Tie Models for Unified Design*. 1st ed. Boca Raton: CRC Press.
- LOGAN, D., 2012. *A First Course in The Finite Element Method*. 5th ed. Stamford: Cengage Learning.
- WIGHT, J. AND MACGREGOR., 2009. *Reinforced concrete mechanics and design*. 5th ed. New Jersey: Pearson.
- OXMAN, R. and OXMAN, R., 2014. *Theories of The Digital in Architecture*. London: Routledge.

استخدام التقنيات الرقمية ثلاثية الأبعاد لتوثيق وإعادة بناء المباني الأثرية المهدمة

هند شمس

المكتب الفني لشركة سيجمان، 64 مصدق، الجيزة

البريد الإلكتروني: h_shams82@yahoo.com

ملخص. تفتقد مصر توثيق الكثير من كنوزها التراثية المتميزة مثل القطع والمباني والصروح والمواقع الأثرية؛ أما الجزء الموثق منها فيودع وثائق تسجيلية في الأدراج وأرفف المكتبات دون أن يراها أحد أو يعلم حتى عن وجودها إلا من بحث عنها للدراسة أو حب الاطلاع، والتي اختفي منه الكثير؛ إما نتيجة إهمال وعوامل التلف والتداعيات الإنشائية المختلفة، وأما نتيجة هدم. وحدث ولا حرج عن عدد المباني الأثرية التي تم هدمها لتخطيط شوارع مكانها، وبالأخص في مدينة القاهرة التي تمتلك أكثر من ثلث آثار الحضارة الإسلامية التي مرت بها، ويظهر ذلك التغيير من خلال مقارنة ما وصفه علماء الحملة الفرنسية لمصر عام 1798 والصور التي أخذت لها من عام 1899 إلى عام 1920 مع ما بعدها؛ مما أدى لإفقدان الكثير من التراث المهم دون أن يراه كثير من الأجيال التي تبعت دماره، فلو تمكنت هذا التراث من الكلام لحكي لنا ما لم نستطيع أحد أن يحكيه؛ لذلك أصبح مجال الحفاظ على هذا التراث أحد الأولويات الهامة على المستوى الدولي لمواجهة تلك المشاكل، والتي تطور أساليبه مع ظهور الثورة الرقمية وما تقدمها من تقنيات وإمكانيات تكنولوجية حديثة، والتي سبقتنا في استخدامها الكثير من الدول الأوروبية والغربية للحفاظ على آثارهم ولتأكيد هويتهم، ومن هذه التقنيات النماذج المعلوماتية المكانية ثلاثية الأبعاد التي دخلت تقريبًا في كل المجالات، وأصبحت ضرورية لمنافع الحياة، ومطلبًا مستمرًا من الجيل الحالي وجيل المستقبل، والاتجاه لاستخدامها في عمل نماذج افتراضية ثلاثية الأبعاد لهذا التراث؛ أما من خلال التسجيل الفوتوجراممري والفوتوغرافي ومسح الليزر ثلاثي الأبعاد، وأما من خلال تسجيل الجرافيك عن طريق برامج الحاسب الآلي مثل: (AutoCAD - 3DMax) لاستغلالها في توثيق الأثر بالرسومات الثنائية والثلاثية الأبعاد، وإدراكهم أيضًا أنها تتناسب مع الأجيال القادمة؛ يتناول هذا البحث استخدام تقنية نمذجة معلومات البناء "BIM" Building Information Modeling في تسجيل وتوثيق وتخيل لإعادة البناء التراث، وبالأخص المباني الأثرية المهدمة جزئيًا أو كليًا، وذلك من خلال ما ورد عنه في الوثائق الأثرية من وصف كتابي أو صور أو رسومات... الخ، واستغلال التقنية في تطبيق علم الآثار الافتراضي، وإعادة بناء وتكوين المباني أو المنشآت أو القطع الأثرية افتراضيًا على الحاسب في حقب ثابتة؛ بهدف توفير طريقة للحفاظ على التراث بتكلفة أقل من الطرق الحديثة ذات التكاليف المرتفعة، وتوفير مكتبة لعناصره المعمارية الفريدة، وإحياء الوثائق الأثرية للآثار، وكذلك الاستفادة منها في عمليات الصيانة والترميم، وتوفير مادة علمية يمكن الاستفادة منها في دراسات قادمة تعمل على توجيه وتطوير الأليات المستخدمة للحفاظ على التراث.

الكلمات المفتاحية. إعادة البناء - إعادة الإعمار - التسجيل والتوثيق - نمذجة معلومات البناء "BIM" - المباني الأثرية المهدمة.

1. مقدمة

1.1. التراث وإعادة البناء

مرت العمارة المصرية على مر العصور بالعديد من الحضارات بداية من الحضارة الفرعونية منذ آلاف السنين، ومرورًا بالحضارة الإغريقية والرومانية، وانتهاءً بالحضارة الإسلامية؛ وقد تأثرت هذه العمارة في كل عصر من العصور بالحضارة السائدة حينها، فجاءت معبرة تعبيرًا دقيقًا عن تلك الحضارات المختلفة.

وقد قامت منظمة اليونسكو لعام 1972 بتعريف التراث الثقافي والطبيعي من خلال تصنيف هذا التراث لعدة أقسام رئيسية، وهي كالاتي: التراث الثقافي المادي (الأثار - الأعمال المعمارية- المواقع - التراث الطبيعي) والتراث الثقافي غير المادي (اللغات -الموسيقى - الفنون الشعبية والتعبيرية) والتراث الوثائقي: الذي يضم كافة الأعمال المدونة سواء المكتوبة أو المطبوعة بمختلف اللغات (اتفاقية حماية التراث العالمي الثقافي والطبيعي، 2004) وللحفاظ علي هذا التراث ويوجد إجراءات وأساليب يتم تحديدها طبقًا للمعايير الدولية التي حددتها منظمة اليونسكو، أو المواثيق الدولية الصادرة عن (ICOMOS) مثل: الحماية (Preservation)، والترميم أو الإعادة للوضع الأصلي (Restoration)، وإعادة الاستخدام (Reuse)، وإعادة التأهيل (Rehabilitation)، وإعادة البناء (Reconstruction)؛ والتي يطلق عليها أيضًا درجات التدخل في الحفاظ (Feilden, 2003).

وقد أوضح المحاري (2017) أن إعادة البناء هي عملية إعادة إنشاء جديدة لموقع أو مبنى ما تعرض لظروف معينة أدت إلى تدميره، وإعادته بشكل كامل أو لأجزاء وملاح غير موجودة، وذلك بهدف نسخ مظهره وشكله الذي كان يتميز به في فترة زمنية محددة. وأن هذه العملية لا تتم إلا في حالتين هما: حفظ وتحسين القيمة الجمالية وعرضها للجمهور بصورة مفهومة، أو بغرض تدعيم وتقوية الأثر أو المبنى كإجراء للحفاظ عليه؛ وتعرف هذه الدرجة أيضًا بمصطلح إعادة الإعمار (شعبان، 2017) وهو المسمى الذي يطلق حاليًا علي عملية إعادة البناء لكاتدرائية نوتردام الأثرية (الشرق الأوسط، 2019) وعملية إعادة البناء لآثار دولة سوريا (بوابة الأهرام، 2017).

وهناك نوعان أساسيان لعمليات إعادة البناء أو الاستكمال للمباني الأثرية القديمة، وهما:

1. إعادة التكوين Anastylis. 2. إعادة البناء Reconstruction.

وهما ما نصت عليهما المواثيق الدولية عند محاولة استكمال الأثار مثل ميثاق أثينا 1931، وميثاق فينسيا 1964. ولأن هذا النوع من التدخل نادرًا ما يتم اللجوء إليه حتى لا تفقد الأثار هويتها، فإنه يتم الاتجاه حاليًا لاستخدام التقنيات الرقمي لتوثيق وإعادة بناء الأثار وذلك من خلال النماذج الافتراضية ثلاثية الأبعاد، وطباعتها بالطابعات ثلاثية الأبعاد ثم إعادة بنائها، أما في المكان الأصلي للأثر، أو بالسفر به لدول العالم ليراه الجميع؛ مثل ما حدث في أثر بوابة مدينة تدمر السورية (جويده، 2016)، ويظهر ذلك في الرسم (1).



الرسم 1. بوابة تدمر الأصلية علي اليمين، والبوابة بعد طباعتها علي اليسار (عن جويده، 2016)

2.1. التوثيق

وتعتبر عملية التسجيل والتوثيق أحد الإجراءات الهامة التي تتطلبها عمليات الحفاظ والمطلوبة في حد ذاتها لتسجيل وتوثيق المباني التاريخية والأثرية والمظاهر التي طرأت عليها عبر مختلف العصور؛ حيث أن التوثيق هو جميع العمليات التي من شأنها جمع وتسجيل كل البيانات والمعلومات المتعلقة بالأثر (سواء كان ثابتاً أو منقولاً)، والتي تشمل الوصف (المعماري والتاريخي ... إلخ) والرفع المعماري (في صورة مساقط ومناظير ثلاثية الأبعاد) والصور وغيرها من الوسائط والوسائل التي استخدمت في الماضي، وأيضاً جميع هذه البيانات بعد تحديثها في الوقت الحالي بالوسائل والتقنيات الحديثة في سبيل المحافظة على الآثار بشتى أنواعها، وصيانتها من التلف في الحاضر والمستقبل (شمس، 2020).

ويتلخص أهمية التوثيق بأنه طريقة فعالة تساهم في إدارة البيانات والمعلومات التي تخص التراث المعماري، وتساعد في إرشاد وتوجيه المسؤولين والمتخصصين بخصوص التعامل الأفضل مع التراث، وتكون بمثابة كتاب مفتوح يمكن استخدامه والاستفادة منه كخبرة لتجارب مماثلة مستقبلاً (موسى، والقاضي، والأرياني، 2010) وأنها أول خطوات استدامة البيئات التراثية، وذلك من خلال مؤسسة مسؤولة عن تجميع وتوثيق وإظهار كافة جوانب التراث العمراني (راشد، 2004).

وقد تم تقسيم طرق التسجيل والتوثيق إلي طريقتين (النمرة وجعفر، د.ت)، وهما:
1. الطرق التقليدية: هي الطرق التي تعتمد علي المجهود اليدوي والقدرات الفردية وأدوات القياس التقليدية، ومن أدواتها: الوصف الكتابي - الرسم - التسجيل الهندسي - التصوير
2. الطرق الحديثة: وهي الطرق التي تعتمد علي استخدام وتطبيق أحدث التقنيات العالمية المتطورة التي تساعد في إدخال البيانات والمعلومات بشكل رقمي علي الحاسب الآلي، ومن أدواتها:

الفوتوجراممري Close Range Photogrammetry

ماسح الليزر ثلاثي الأبعاد 3D Laser Scanning

الاستشعار عن بعد والتصوير الجوي Remote Sensing

نظم المعلومات الجغرافية "GIS" Geographic Information System

النماذج الافتراضية ثلاثية الأبعاد 3D Virtual Model

وقد نص ميثاق لاهور 1980 والخاص بصيانة وترميم التراث المعماري الإسلامي علي: أنه "يجب استخدام التقنيات التقليدية كلما أمكن ذلك، فإذا ثبت قصورها فيتم استخدام التقنيات الحديثة التي تكون قد أثبتت فعاليتها بالبيانات العلمية والتجربة".

2. نحو نمذجة التراث

وتعتبر تقنية الـ "BIM" أحد التقنيات المبتكرة في مجال العمارة والتشييد، وهي احد مراحل التطور للنماذج الافتراضية ثلاثية الأبعاد، فالـ "BIM" هي تصميم رقمي ثلاثي الأبعاد لمبني ما بتفاصيله وعناصره المعمارية والإنشائية وحتى الإلكتروميكانيكية في شكل نموذج متكامل به كل المعلومات؛ ليساعد في اتخاذ القرارات، وتلافي المشاكل التي تحدث في الموقع نتيجة اكتشاف التعارض أثناء العمل ومنها أعمال الترميم (شمس، 2020).

وقد دخلت تقنية الـ "BIM" في العديد من المجالات التعليمية والترفيهية والأثرية والهندسية بتخصصاتها؛ حتي أن فكرة ومفهوم نمذجة المعلومات استخدمت في مجالات لا تخص مجال البناء، ومن أمثلة هذه المجالات: مجال صناعة الإكسسوار الإلكترونية، ومجال صناعة السيارات، والمجال الرياضي، ومجال التسوق، حتي مجال الألعاب (البناء، 2017، أ؛ ب؛ ت) وقد تم أيضاً الجمع بين تقنية الـ "BIM" وبين الكثير من التقنيات التكنولوجية الحديثة للوصول إلى أقصى استفادة في المجالات المختلفة، ومنها أدوات الطرق الحديثة للتسجيل والتوثيق، ويظهر ذلك في الرسم (2).

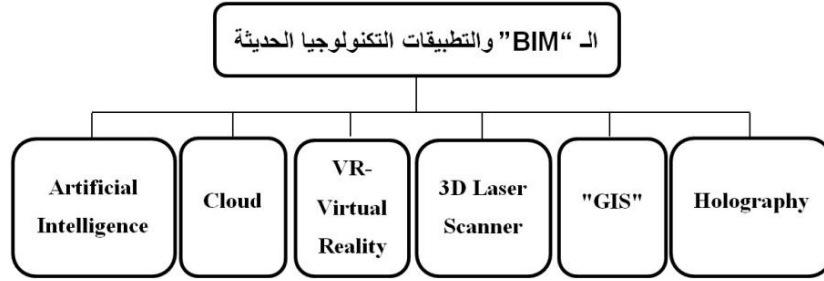

الرسم 2. علاقة الـ "BIM" بالتطبيقات التكنولوجية الحديثة (شمس، 2020)

وأصبحت نمذجة معلومات المباني التاريخية Historical Building Information Modeling "HBIM" هي رواية جديدة للحفاظ علي المباني الأثرية والتاريخية، والتي سبقت في استخدامها العديد من الدول الغربية مثل: إيطاليا وبريطانيا وإسبانيا، وذلك في نمذجة الكثير من هذه المباني الأثرية والتاريخية في مختلف دول العالم لتوثيقها وصيانتها منها: كاتدرائية ساغرادا فاميليا في إسبانيا، قلعة مسقرا في إيطاليا، كاتدرائية ليريكو في ميلانو، وبيت نصيف التاريخي بجدة وغيرها من المباني؛ وذلك لمعرفة فوائد هذه التقنية في مجال الحفاظ علي التراث؛ حيث أن عملية التوثيق الرقمي في حالة الآثار السليمة أو المتضررة جزئياً تكون أسهل بكثير من الآثار المهدمة؛ لأن المبني القائم يمكن استخدام معه تقنية التصوير الفوتوجراممري، أو تقنية ماسح الليزر ثلاثي الأبعاد أو غيرهما، ثم القيام بإدخال هذه المعلومات إلى البرامج المتخصصة من تقنية الـ "BIM" وتحويلها إلى نماذج ثلاثية الأبعاد؛ أما في حالة الآثار المهدمة كلياً فيتم الرجوع لكل المعلومات والوثائق السابقة للأثر من وصف كتابي، أو رسومات، أو صور فوتوغرافية، واستكمالها بالدراسات والاستنتاجات الهندسية والأثرية؛ لاستكمال وإعادة البناء والإعمار لهذه الآثار المنهارة، وحسب هذه الوثائق تتوقف مدى دقة المعلومات ومدى دقة النموذج؛ فإما أن يكون النموذج متكاملًا وبأدق التفاصيل، وإما أن يكون توضيحياً للمظهر العام الخارجي للأثر، ولكن سيعتبر بصمة مهمة للأثر؛ ويظهر الرسم (3) نموذج افتراضي ثلاثي الأبعاد لـ Manchester Town Hall Complex باستخدام التقنية.



الرسم 3. نموذج افتراضي ثلاثي الأبعاد لـ Manchester Town Hall Complex (عن سليم وأحمد، 2017، أ)

- ويمكن تقسم دور الـ "BIM" في مجال الحفاظ علي التراث كالاتي:
1. التوثيق الرقمي للمباني الأثرية والتاريخية.
 2. أعمال الترميم والصيانة للمباني الأثرية والتاريخية.
 3. أعمال الاستكمال وإعادة البناء والإعمار للآثار المنهارة.

استخدام التقنيات الرقمية ثلاثية الأبعاد لتوثيق وإعادة بناء المباني الأثرية المهتمة

4. تنشيط السياحة للمباني والمواقع الأثرية والتاريخية.

وذلك لاستبدال طرق حفظ الوثائق والسجلات الورقية والرسومات ثنائية الأبعاد إلى نماذج رقمية ثلاثية الأبعاد بها كل المعلومات وذات دقة عالية وبأبعاد حقيقية، وتقليل تكاليف إعادة توثيق معلومات المبنى إذا حدث أي تغيير له علي مر الزمن بسبب ظروف غير متوقعة والبحث حينها عن آخر شكل للمبنى قبل تغييره، واستخدام التقنية في استكمال المباني المنهارة جزئياً، وإعادة بناء المباني المنهارة كلياً (افتراضياً أو علي أرض الواقع) وتوفير كل المعلومات وكمية المواد اللازمة لأعمال الترميم، وأيضاً القيام بربط نموذج الـ “BIM” بالواقع المعزز، أو الواقع الافتراضي؛ للاستفادة منها في إعداد خطط الترميم والصيانة وتجربتها، واختبار المواد والطرق المستخدمة في الترميم قبل تنفيذها علي الأثر الحقيقي لمعرفة عيوبها وتأثيرها عليه، والحد من الاختبارات وتكاليفها علي أرض الواقع، والتدريب الافتراضي علي أعمال الترميم، وبناء متاحف افتراضية للأثار علي شبكة الإنترنت.

3. إعادة بناء القباب السبع (السبع بنات) باستخدام الـ “BIM”

تم اتخاذ أثر القباب السبع التي تقع خلف عمارات الفسطاط الجديدة بحي مصر القديمة بالقاهرة للتطبيق عليه؛ حيث هي قباب موجودة في الفسطاط يرجع تاريخ بنائها إلى العصر الفاطمي (400 هـ - 1010م)، وهي من القباب المميزة والآثار القليلة الباقية عن هذا العصر، والتي لا يوجد شبيه لها إلا في جبانة أسوان، ويعتقد بعض العلماء أنها أقدم أضرحة بُنيت عليها قبة في مصر؛ لذلك تتميز هذه القباب بقيمة تاريخية ومعمارية وأثرية، ومع ذلك نجد أن الكثير من الذين تكلموا عن الآثار الفاطمية نسوا ذكرها، وتظهر الرسم (4) أثر القباب السبع في الفسطاط.



الرسم 4. القباب السبع في الفسطاط (عن الباحثة)

وقد تم اختبار أثر شبه مهدم للتطبيق عليه للتأكد من التوثيق السابقة لهذا الأثر من وصف وصور فوتوغرافية ورسومات هندسية؛ لأنه عند توثيق أثر مهدم كلياً يجب أن تكون الوثائق السابقة والموجودة له ذات مصداقية عالية من الدقة وبالأخص الوصف الكتابي والرسومات الهندسية، ثم استكمالها بالدراسات والاستنتاجات الهندسية والأثرية لاستكمالها وإعادة البناء والإعمار له. وتم استخدام برنامج Revit لعمل النموذج ثلاثي الأبعاد للأثر لما له من مميزات عديدة، ومن أهمها: فهم نظام تشغيل البرنامج لعناصر المبنى وأنها وحده واحدة مثل: الحوائط والنوافذ والأبواب - وهي خاصية العائلات (Families) - واستخدامها لحل مشكلة عدم وجود مكتبة معمارية لعناصر

المباني الأثرية والتاريخية، وسهولة استخدامه مع الطرق التقليدية والحديثة في عمليات التوثيق؛ حيث يمكن إدخال الغيوم السحابية الناتجة عن المسح بالليزر إليه، وتحويلها إلى نموذج ثلاثي الأبعاد، وإضافة الصور الناتجة عن التصوير الفوتوجراممري عليها، وأيضًا كونه من البرامج القليلة التي تخرج نموذج بأبعاد حقيقية بخلاف برامج أخرى تخرج نموذج شكلي فقط، وسهولة الحصول منه علي جداول الحصر ومعرفة الكميات المطلوبة في عمليات الترميم والاستكمال.

1.3. نبذة تاريخية ومعمارية عن الأثر

القباب السبع هي قباب بنيت على عدة أفراد من أسرة الوزير أبو القاسم الحسين بن علي المغربي الذي قتلهم الخليفة الحاكم بأمر الله بعد أن هرب أبو القاسم من مصر، ثم بعد ذلك أمر الحاكم ببناء هذه القباب عليهم لإرضائه بعد أن أثار عليه ولاة شبه الجزيرة العربية (السخاوي، 1937) وقد ذكر السكري أنها شاعت باسم قباب السبع بنات في أواخر العصر العثماني (عثمان، 2006) والمعروفة بها حتي الآن. وقد صحح السخاوي (1937) عدد القباب وأنها "في الحقيقة ست قباب... وهم والد الوزير وأخوه وثلاثة من أهل بيته... وكان إلى جانبها قبة أخرى فسميت بالسبع القباب بهذا الاعتبار" (ص. 170). ويوجد حاليًا في موقع القباب السبع: أربع أضرحة فقدوا قبابهم ويغطي حوائطهما بقايا طبقة من الجص وبقع من الحناء وهبو الدخان، ويوجد أطلال من الحوائط لضريحين وأحواش كانت تحيط بكل ضريح، ويحيط بهم سور من الأحجار الغير منتظمة والقمامة التي تغطي الموقع العام تقريبًا بالكامل. وقد بُنيت هذه القباب علي محور واحد تقريبًا من الجنوب الغربي إلى الشمال الشرقي ما عدا القبة التي في اتجاه الجنوب الغربي، وتتكون الأضرحة الأربعة الموجودة حاليًا من ثلاث طوابق متدرجة: اتخذ فيها الطابق الأول كقاعدة مربعة الشكل بنيت من الحجر الدبش ويتوسط تقريبًا كل ضلع من أضلاعه فتحة ذات عقد مدبب، والذي يحمل فوقه منطقة انتقالية استخدم فيها الحنايا الركنية- وهي نفس الموجودة في قبة جامع الحاكم بأمر الله - وكل ضلع لها مثقوب بنافذة تتناسب مع الأبواب السفلية، وتحمل فوقها طابق ثماني الأضلاع يستخدم كقاعدة للقبة، وهو مثقوب بثمانية نوافذ، وأن هذين الطابقين بُنيا من الطوب الأحمر المحروق تمامًا، وكانت طوابق الأضرحة مغطى تمام بالجص من الداخل والخارج والتي فصل بينهم بحلية من الطوب، أما القبة الكروية الشكل فقد فقدت بالكامل.

2.3. بناء النموذج للأثر

وقد تم الرجوع لكل الوثائق الأثرية لأثر القباب السبع قبل البدء ببناء النموذج الافتراضي ثلاثي الأبعاد له، وهي كانت عبارة عن رسومات هندسية وصور فوتوغرافية مأخوذة عن كريزويل لهذه الأضرحة، ويظهر ذلك في الرسم (5)، وأيضًا تقرير فنية وصور فوتوغرافية مأخوذة عن لجنة حفظ الآثار العربية، ويظهر ذلك في الرسم (6).

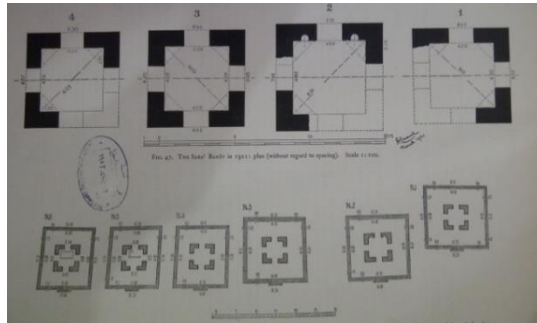

الرسم 5. المساقط الأفقية (عن CRESWELL, 1952)



الرسم 6. القباب السبع سنة 1911 (عبد التواب، 2007)

وقد تم إتباع هذه الوثائق في خطوات العمل لأنها ستكون المصدر الأساسي والوحيد في المباني الأثرية المهدامة كلياً؛ ومع ذلك تم مراجعة الأبعاد التي ذكرها كريزويل مع الأبعاد الحالية للأضرحة التي تم رفعها أثناء الدراسة الميدانية للأثر؛ لتأكد من دقتها، وتم استنتاج أي أبعاد غير موجودة في الوثائق من خلال الصور التي اتخذت للأثر، وإتباع الخطوات التالية لبناء النموذج:

1. البدء بعمل مستويات لكل ارتفاع طابق في البرنامج، واتخاذ الصفر المعماري من معبرة العقد المفتوح وسط كل واجهة (معبرة الأبواب) بالأخص العقد الموجود في حائط واجهة القبلة؛ لأنه هو الحائط الوحيد الذي لم يهدم منذ بناء الأثر، ثم البدء في رسم حوائط الطوابق لكل ضريح على حدة، وذلك بعد تعديل خصائصها في البرنامج مثل: تحديد نوع مادة البناء المستخدمة في كل حائط من حجر أو طوب، وتم استنتاج ارتفاع الطابق الثالث للضريح الأول الذي لم يسجله كريزويل بسبب دماره من خلال عد الطوب الذي استكمل من خلال لجنة حفظ الآثار العربية، ومقارنته بعدد طوب أي ضريح استكمل أيضاً من خلال اللجنة، وأخذ ارتفاعه مما سجله كريزويل عنه، وهي كالاتي:

الجدول 1. استنتاج ارتفاع الطابق طبقاً لعدد الطوب المستكمل للطابق.

الضريح الأول	الضريح الثاني	الضريح الرابع	
؟	1.95	1.77	ارتفاع الطابق الثاني بالمتر
25	26	24	عدد الطوب المستكمل للطابق

إدًا فإن ارتفاع الطابق الثاني في الضريح الأول هو متوسط مجموع الارتفاعين وهو 1.86 م.
2. البدء في وضع الأبواب والنوافذ والحنايا الركنية ذات العقد المدبب (ذات الأربعة مراكز) في أماكنها بعد بناء العناصر بارتفاعاتها المختلفة، وذلك بناء على الصور المأخوذة عن الأثر، وما أشار إليه كريزويل؛ حيث تم الاستعانة بالكود المصري لتصميم وتنفيذ المباني لتصميم العقد المدبب لهم (اللجنة الدائمة لأعداد الكود المصري، 2005) وقد تم حساب ارتفاع الباب بعد الأحجار المجاورة له وضرب الناتج في ارتفاع الحجر؛ إما النوافذ فتم حساب ارتفاعها من حاصل ضرب عدد الطوب الذي بجوار النافذة في سمكه، وإما من طرح ارتفاع مدماك من ارتفاع هذا الطابق؛ بمعنى أن ارتفاع نافذة الطابق الثاني في الضريح الثاني يحسب بالطريقتين كالاتي:

أ. وهو يساوى $1.95 - 0.07 = 1.88$ م (حاصل طرح مدماك من ارتفاع الطابق).

ب. وهو يساوى $25 \times 0.075 = 1.88$ م (حاصل ضرب عدد الطوب في سمك الطوبة شاملاً

سمك المونة)؛ وبنفس الطريقة تم حساب ارتفاع باقي الأبواب والنوافذ لباقي الأضرحة.

3. رسم الحليات البارزة والفاصلة بين كل طابق بعد تعديل أساس وحدة عائلة الحلية الموجودة في البرنامج بوحدة الطوبة، ووضع المحرابين في مكانهما بالضريح الثاني الذي يتميز بهم عن باقي الأضرحة بعد بناء العنصر لهما، وبناء حوش كل ضريح بارتفاع 90 سم.

4. استكمال القبة بالشكل الكروي للأضرحة الأربعة؛ وذلك من خلال الدراسات السابقة التي تثبت أنها شبيهة لبعض قبب الأضرحة الموجودة في جبانة أسوان، والتي تعود أيضاً للعصر الفاطمي.

5. تم بناء الضريح الخامس والسادس من أقرب أضرحة لهما في أبعادهما؛ حيث تم اتخاذ الضريح الخامس من الضريح الرابع والضريح السادس من الضريح الثالث، وهما أقرب مباني لهما في ضلع

القاعدة كما سجل كريزويل، ويظهر ذلك في الشكل (4)، وبما أن طول ضلع القاعدة الخارجية للضريح السادس هو نفس طول ضلع القاعدة الخارجية للضريح الثالث، فإذا الضريحان متساويان في كل الأبعاد؛ أما بالنسبة للضريح الخامس تم تنسيب ارتفاعات طوابقه من ارتفاعات طوابق الضريح الرابع؛ حيث لوحظ أن فرق نسبة الارتفاع للضريحين الثالث والرابع هما نفس نسبة المساحة للضريحين، ويظهر ذلك كالآتي:

$$\text{فرق نسبة ارتفاع الطابق الأول للضريحين} = 3.70 / 3.55 = 1.04،$$

$$\text{و فرق نسبة المساحة للضريحين} = 6.44 \times 6.44 / 6.30 \times 6.30 = 1.04،$$

ولذلك تم تنسيب ارتفاع الطابق الأول للضريح الخامس من ارتفاع الطابق الأول للضريح الرابع بحساب فرق نسبة المساحة للضريحين كالآتي:

$$\text{فرق نسبة المساحة للضريحين} = 6.30 \times 6.30 / 6.28 \times 6.28 = 1.01،$$

$$\text{إذا ارتفاع الطابق الأول للضريح الخامس بالنسبة للضريح الرابع} = 3.55 / 1.01 = 3.53 م،$$

وارتفاع الطابق الثاني = 1.77 / 1.01 = 1.75 م، وارتفاع الطابق الثالث لنفس الضريح = 1.55 م. بعد إنهاء النموذج تم البدء في بناء الوضع التخيلي للموقع العام وقت بناء الأثر، وعمل جداول بيان حصر لمواد البناء المستخدمة في بناء الأثر الحقيقي، ثم اتخاذ اللقطات المناسبة وإخراجها كصور من البرنامج، وأيضًا إخراج جداول بيان حصر بالكميات المواد المستخدمة في البناء.

3.3. القباب السبع بعد بناء النموذج

وتظهر مخرجات البرنامج الأثر كالآتي:

يظهر الرسم (7): نموذج افتراضي للقباب السبع من الجهة الجنوبية - وهو حائط القبلة، ويوضح الجدول (2): بيان حصر بكميات الطوب المستخدمة في بناء الأثر، ويظهر الرسم (8): الواجهات الرئيسية للضريح الأول والثاني الموجودين حاليًا في موقع الأثر من الجهة الشمالية الغربية، ويظهر الرسم (9): علي اليمين نموذج افتراضي للضريح الثاني من الداخل والذي يظهر المحرابان اللذان يتميزان بهما الضريح عن باقي الأضرحة ويظهر أيضًا أحد الحنايا الركنية للضريح، وعلي اليسار الوضع الحالي للضريح من نفس الزاوية وما به من مظاهر تلف بعد إدخال الصور الفوتوغرافية التي تم تصويرها للضريح ووضعها على النموذج ثلاثية الأبعاد.



الرسم 7. نموذج افتراضي للقباب السبع من الجهة الجنوبية (لحائط القبلة) (عن الباحثة)

استخدام التقنيات الرقمية ثلاثية الأبعاد لتوثيق وإعادة بناء المباني الأثرية المهتمة

جدول 2. بيان حصر بطوب الأضرحة (عن الباحثة)

Structural Material	Area	Volume	عدد طوب	Description
حائط طوب	10 m ²	6.08 m ³	3380.264017	طوب
حائط طوب	16 m ²	9.73 m ³	5404.642154	طوب
حائط طوب	43 m ²	21.45 m ³	11918.677675	طوب
حائط طوب	62 m ²	29.71 m ³	16504.271622	طوب
حائط طوب	25 m ²	11.83 m ³	6573.10103	طوب
حائط طوب	30 m ²	10.64 m ³	5908.704892	طوب
حائط طوب	51 m ²	17.29 m ³	9603.618416	طوب
حائط طوب	30 m ²	7.98 m ³	4432.333841	طوب
حائط طوب	31 m ²	9.72 m ³	5402.259879	طوب
Grand total:	297 m ²	124.43 m ³	69127.873526	
96				

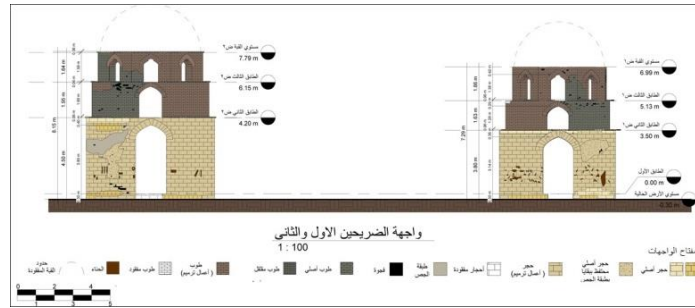

الرسم 8. واجهة الضريح الأول والثاني الموجودين حاليًا في الموقع (عن الباحثة)



الرسم 9. لقطة منظورية داخلية للضريح الثاني علي اليمين، ولقطة للوضع الحالي علي اليسار

وأنه يمكن الاستفادة من هذه المخراجات في ترميم وصيانة واستكمال الأثر، وحساب التكلفة اللازمة لعملية الترميم والصيانة؛ حيث أنه من خلال جدول بيان حصر الكميات الذي تم إخراج معرفته الآتي:
 أن نسبة الحجر: الطوب للأضرحة = $100 / 330$ ،
 وأن المتر المكعب في الطابق الأول للأضرحة = $6 : 6.50$ مدمك = 72 قطعة حجر تقريباً،
 وأنه يلزم لاستكمال الضريح السادس إلي 67 متر مكعب من الحجر، وعدد 10770 طوبة تقريباً.

5. النتائج والتوصيات

وبذلك أثبتت منهجية البحث المتبعة في تطبيق تقنية الـ“BIM” أنها مفيدة جدًا في مجال الآثار لإحياء الوثائق التاريخية، وتوثيق الآثار بالطرق والتقنيات الحديثة، وتوفير المعلومات لعمليات الترميم والصيانة وإعادة التأهيل والاستخدام للحفاظ على الآثار، وفي التنشيط السياحي لها بتوفير نماذج افتراضية ثلاثية الأبعاد للمتاحف والجولات الافتراضية، والاستفادة منها في الفترات التي تتوقف فيها حركة السياحة للآثار في مصر أو العالم عند انتشار الأوبئة والهجمات الإرهابية، وأيضًا لاستخدامها في عمل واقع افتراضي للمناطق الأثرية والمدن التاريخية بالكامل.

وأنه يمكن اتباع هذه المنهجية مع باقي المواقع الأثرية بالخطوات الآتية:



وتعد هذه الطريقة أيضًا طريقة بديلة لتوثيق المباني دون الحاجة إلى استخدام الأجهزة والتقنيات الحديثة المكلفة في عمليات التوثيق مثل: تقنية الفوتوجراممري، أو تقنية ماسح الليزر ثلاثي الأبعاد والتي لا تتناسب مع توثيق المباني الأثرية المهدامة كليًا؛ لعدم إمكانية القيام بعملية المسح ثلاثي الأبعاد لها؛ ولأن تكلفة شراء أو استئجار هذه الأجهزة أحيانًا تكون أعلى من التكلفة المسموحة لعملية التوثيق من خلال الجهات المعنية والتي لا تسمح باستخدام هذه الأجهزة؛ لذلك توصي الدراسة بالآتي:

1. تشجيع الرسائل العلمية التي تبحث في مجال التوثيق للآثار؛ لأن نسبة عدد الدراسات في هذا المجال قليلة جدًا بالنسبة للدراسات الأخرى.
2. تشجيع الأبحاث التي تستفيد من تقنية الـ“BIM” في الحفاظ على الآثار؛ لمعرفة الفوائد المرجوة منها عند استخدامها في المشروعات الأثرية.
3. إدخال تقنية الـ“BIM” كمنهج من برامج الحاسب الآلي في مناهج كليتي الهندسة والآثار؛ ليوكب خريجي الكليتين مع التطور الرقمي الموجود حاليًا.
4. عمل ورش لتطبيق تقنية الـ“BIM” بمجال الآثار للمتخصصين في هذا المجال للقيام بنشر تراثنا بطريقة حديثة، وتحويل الوثائق الأثرية نحو التقارب الرقمي؛ بهدف تشجيع وصول الجمهور العام إلى التراث الثقافي.

الشكر

الشكر لمعلميني في كلية الهندسة-جامعة المنصورة وفي دبلوم الترميم المعماري-قسم الترميم-كلية الآثار - جامعة القاهرة.

المراجع

اتفاقية حماية التراث العالمي الثقافي والطبيعي. (2004). استرجعت (أبريل 4، 2019) من [http://whc.unesco.org/fr/conventiontext\(arabic\)](http://whc.unesco.org/fr/conventiontext(arabic))

البناء، معتمص:

- ما هو الـ BIM؟ الجزء الأول. (2017، أ)، مجلة BIMarabia، العدد الثامن عشر، ص ص. 4-8
- ما هو الـ BIM؟ الجزء الثاني. (2017، ب)، مجلة BIMarabia، العدد التاسع عشر، ص ص. 17-21.
- فرض المملكة المتحدة لنمذجة معلومات البناء – أين نبدأ؟ (2017، ت)، مجلة BIMarabia، العدد الواحد والعشرون، ص ص. 32-35.
- السخاوي، أبي الحسن نور الدين علي بن أحمد بن عمر بن خلف بن محمود. (1937). تحفة الأحياب وبغية الطلاب في الخطط والمزارات والتراجم والباق المبركات. القاهرة: مطبعة العلوم والآداب.

استخدام التقنيات الرقمية ثلاثية الأبعاد لتوثيق وإعادة بناء المباني الأثرية المهتمة

- الشرق الأوسط. (2019). لعبة فيديو شهيرة قد تساعد في إعادة بناء كاتدرائية نوتردام. استرجعت (17 أبريل، 2019) من <https://aawsat.com/home/article/>
- اللجنة الدائمة لأعداد الكود المصري لأسس تصميم و اشتراطات تنفيذ أعمال المباني. (2005). الكود المصري لتصميم وتنفيذ المباني "كود رقم 204-2005". المركز القومي لبحوث الإسكان والبناء، وزارة الإسكان والمرافق و المجتمعات العمرانية، القاهرة.
- المحاري، سلمان. (2017). حفظ المباني التاريخية "مبان من مدينة المحروق". الشارقة، الإمارات: المركز الإقليمي لحفظ التراث الثقافي في الوطن العربي (إيكروم).
- المنيرة، نادر جواد وجعفر، أشرف عبد المنعم. (د.ت). الطرق الحديثة في التوثيق المعماري للمواقع الأثرية في فلسطين "حالة دراسية- تجربة مركز إيون في التوثيق المعماري للمواقع الأثرية في البلدة القديمة بغزة باستخدام GIS". استرجعت (14 نوفمبر، 2017) من http://www.cpasegypt.com/pdf/Ashraf_Gaafar/Researches/010.pdf
- بوابة الأهرام. (2017). نموذج ثلاثي الأبعاد لمدينة تدمر الأثرية تسلمه روسيا إلى سوريا. استرجعت (20 أغسطس، 2019) من <http://gate.ahram.org.eg/News/1643125.aspx>
- جويده، فاروق. (2016). "متحف المستقبل" يشارك في إعادة بناء "توأم" بوابة تدمر. العين الإخبارية. استرجعت (11 إبريل، 2019) من <https://al-ain.com/article/127236>
- راشد، أحمد يحيى. (2004). استخدام البيانات التراثية: توثيق العمران التراثي كمدخل لعملية الحفاظ "دراسة لقلعة الرملة بمدينة العين". استرجعت (15 ديسمبر، 2017) من http://www.cpasegypt.com/pdf/Ahmed_Rashed/
- شعبان، محمد. (2017). كلمة العدد "أفاق استخدام البيم في مشاريع إعادة إعمار سوريا". مجلة BIMarabia، العدد الخامس والعشرون، ص. 2.
- شمس، هند أحمد (2020). استخدام تقنيات بناء النماذج الحاسوبية ثلاثية الأبعاد لتوثيق وتسجيل واستكمال وإعادة بناء المباني الأثرية المهتمة - تطبيقاً على مبنى مختار. رسالة ماجستير في الترميم المعماري، قسم الترميم، كلية الآثار، جامعة القاهرة.
- عبد التواب، عبد الرحمن. (2007). كراسات لجنة حفظ الآثار العربية "الكراسة 28" (تقديم د/ زاهي حواس). القاهرة: المجلس الأعلى للآثار.
- عثمان، محمد عبد الستار. (2006). العمارة الفاطمية: عمارة المشاهد والقباب "في العصر الفاطمي ج2"، موسوعة العمارة الفاطمية. القاهرة: دار القاهرة.
- موسى، محمد والقاضي، شوكت والأرياني، سحر. (2010). استخدام تقنيات التوثيق في الحفاظ على التراث المعماري "الجامع الكبير باليمن كمثال تطبيقي". ورقة مقدمة إلي المؤتمر الدولي الأول للتراث العمراني في الدول الإسلامية، الهيئة العامة للسياحة والآثار، الرياض، السعودية، 23: 28 مايو، 2010.
- CRESWELL, K.A.C. (1952). *THE MUSLIM ARCHITECTURE OF EGYPT "IKHSHIDS AND FATIMIDS"*. London, UK: Oxford.
- Feilden, B. M. (2003). *Conservation of historic buildings* (3rd ed.). London, Britain: Architecture press

A HUMAN-CENTRED FRAMEWORK FOR SONIC MAPPING

Developing Representation Methods to Analyze Sonic Environments

ADAM HANNOUCH

University of Sydney, Australia

148 City Road

Darlington, NSW 2008, Australia

Email address: adam.hannouch@sydney.edu.au

Abstract. This paper contributes to a new way of bringing the human physically into the *in-situ* environment and utilizing mapping methods of the actual sonic experience, which current acoustic studies and other environmental studies are lacking in their reliance on graphical representations. An entire era has been dominated by a visual communication of the sonic environment, yet sonic studies are not primarily dependant on visual experience. The paper reviews the possibilities of current methods of representation of the sonic experience. Representation, being crucial in the layperson's perceptive awareness of key features of the environment can benefit from increased levels of listening methods. This includes mapping the qualities of information that reveal the environment.

Keywords: *3D Modelling, Representation, Sonic Environments, Sonification.*

ملخص. تساهم هذه الورقة البحثية في طريقة جديدة لانتقال الإنسان بشكل ماديا إلى ما يشبه بيئة الموقع واستخدام طرق رسم الخرائط الصوتية الفعلية ، والتي تفتقر إليها الدراسات الصوتية الحالية والدراسات البيئية الأخرى في اعتمادها على عرض الرسومات التصوري. سيطر الاتصال المرئي للبيئة الصوتية على حقبة بأكملها ، لكن الدراسات الصوتية لا تعتمد بشكل أساسي على التجربة البصرية. تستعرض الورقة إمكانيات الأساليب الحالية لتمثيل التجربة الصوتية باعتبارها حاسماً في الوعي الإدراكي للشخص العادي للسمات الرئيسية للبيئة . كما يمكن أن يستفيد من المستويات المتزايدة لطرق الاستماع. يتضمن ذلك تعيين خصائص المعلومات التي تكشف عن البيئة

الكلمات المفتاحية: النمذجة ثلاثية الأبعاد ، التمثيل، البيانات الصوتية ، الصوت.

1. Background

Acoustics itself as a study in architecture does not engage the environment nor its landscape and texture as a fundamental principle of design. This is where the study of soundscapes may come in, a branch of sound perception in relation to our mind, which is a recently emerging appreciation of acoustic ecologies theorised by Murray Schafer (1977). This environmental study is yet to be framed by architecture and architecture is yet to find an organized relation to sound perception. The focus of this paper is not about developing ways to measure the soundscape or even to evaluate cognitive results of sonic experience. This paper forms part of a research on exploring alternative ways to represent sounds behaviour in the outdoor environment and providing the designer with parameters to help control the spatial qualities that are integral to the impact of the sonic experience.

1.1. SOUNDSCAPE STUDIES

In the context of the soundscape in the natural ecology, sounds are often classed under *geophony* (sounds produced by the geophysical environment such as rain, wind and thunder), *biophony* (sounds produced by animals and plants) and *anthrophony* (sounds produced by humans), as proposed by Pijanowski, et al., 2011. This research also includes *technophony* to the list of sound classifications, which narrows down anthrophonic sounds to technological induced sounds.

2. Urban Scene Recordings

2.1. SOUND SCENE LISTENING

This research, however, will take the lab out into the field and test aspects of the soundscape using the designer as the agent. This looks at methods of collecting data directly from the site of interest and in the perspective of the human listener. This employs a recording task for sound scene listening with a reliance on the ear as the tool for collecting data. This involves categorizing sounds during the sound listening task, identifying locations for soundscape recording and experimenting, and an analysis of soundscape quality which can help the designer highlight and address points of improvement for the sound listening experience.

The types of sites surveyed, in Sydney's CBD, are places 'intended' for sonic refuge within the urban environment. Recordings take place from two open spaces and two semi-open spaces for comparison and require three conveniently portable apparatus for recording data. These include the ear, for

natural listening; a sound recording device, which can be a smart phone; and a digital sound level meter to measure sound pressure levels (dB or dBA). The sound listening task, which is inspired by Murray Schaffer's (1992), 'A Sound Education', is a simple step-by-step method as seen in Figure 1. Once the listener is in place, they would begin listening to the sounds they can hear while simultaneously recording the sound scene and sound pressure levels with their devices for an entire two minutes. Throughout the duration of this time, the listener would list all of the sounds they can hear. After this is complete, the listener would order these sounds in the following: i. from loud to soft; ii. the persistence of sounds, being continuous, repeated, or unique; iii. the distance from which the sounds came to you; and iv. in natural, animal, human and technological sound categories. Following this, the listener can run the playback of the sound scene and list the sounds initially undetected through natural listening, and additionally, if the task is performed with a group, the listener can compare the sounds heard and their categorization of sounds with their peers.

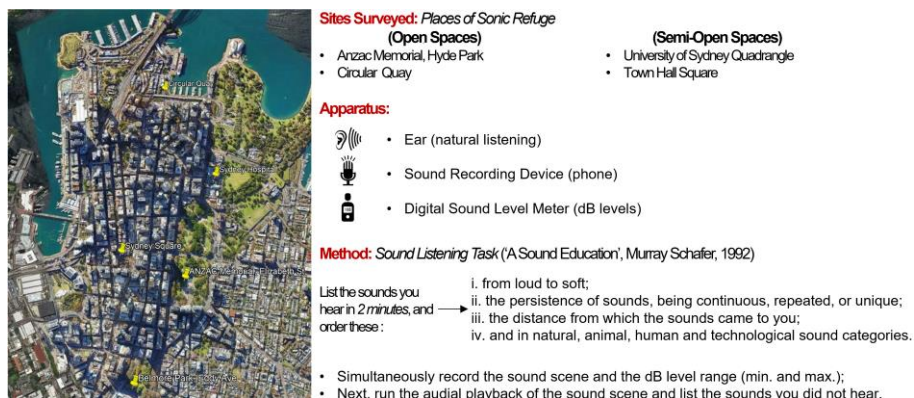

Figure 1. Sound Scene Listening for collecting data from existing urban soundscapes.

3. Data Representation

Listening tasks have found sounds that tend to be more preferable in open spaces, namely natural sounds and more characteristic or meaningful sounds are not outweighed by less preferable sounds in terms of loudness (dBA). For example, in two contrasting scenarios, such as at a central memorial (1A) and the edge of a key promenade (3), maximum recordings of 79.7 dB and 74.45 dB were made, respectively. Given the small difference in sound pressure levels, or noise levels in terms of policy planning, we cannot solely rely on complying with recommended noise levels to maintain sonically healthy environments. Similar indifferences in sound pressure levels in

A HUMAN-CENTRED FRAMEWORK FOR SONIC MAPPING

highly contrasting sonic events are recorded even in natural soundscapes. That is, events consisting entirely of biological activities and vocalizations (biophony) and geophysical sounds and meteorological events (geophony). Other parameters are clearly at play and these results could suggest that a shift in standard noise policies can be afforded to give way to new units of measurements in place of loudness. The paper then explores different methods for representing the data taken down at each urban space in 2.1.

3.1. 2D TAXONOMY

The first method involves taking the data from the initial listening tasks and generating a graphical 2D taxonomy. This maps the different characteristics of all recorded sounds, as seen in Figure 2. The representative collection of data from more desirable sound scenes would preferably indicate a higher range of sounds, a higher range of perceived distances, a larger proportion of natural and animal sounds, and less undetected sounds, present a more pleasant outdoor sound scene, and this is to be cross-compared with questionnaires from listeners about the outdoor sound quality. Of the six locations and positions recorded, technological sounds mostly dominate and there is always a vast range of perceived loudness, as seen in Figure 3. A key distinction is drawn between the analysis of the open spaces, which tend to be blurred with a continuous sound or background sound, and in semi-open spaces, which consist of a discrete awareness and attention to almost each individual sound and a significantly less technologically dominating sound scene, while lacking any constantly perceived background sounds.

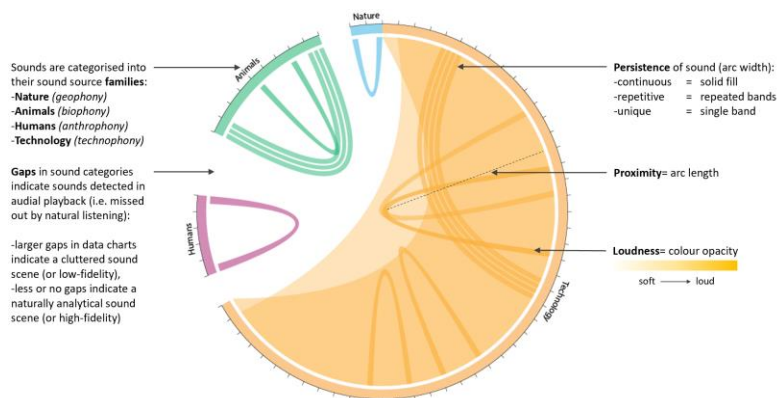

Figure 2. A graphical 2D taxonomy which maps the different characteristics of sounds.

A. HANNOUCH

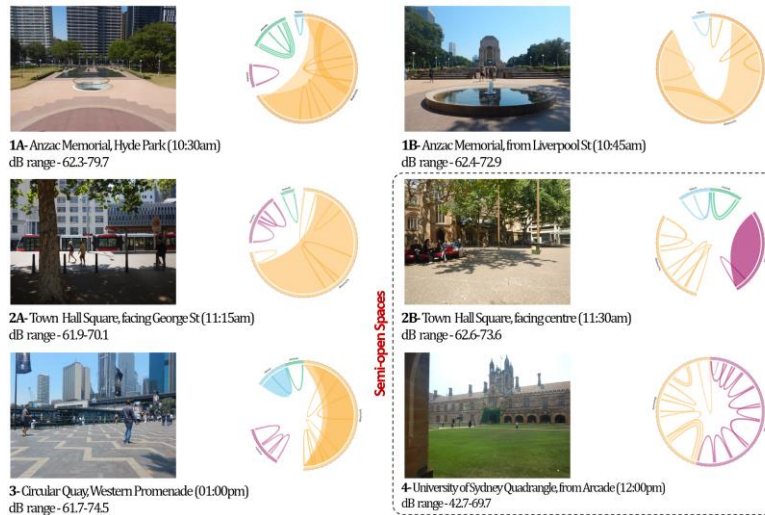

Figure 3. The 2D taxonomy is used to map the sound scenes of the four different Sydney CBD locations.

3.2. SPECTROGRAMS

In order to analyze the acoustic ecologies of different animal species and to understand temporal patterns in their specific habitats, ecologists tend to record and observe data on spectrograms. Spectrogram data of specific species or overlaps of species in shared habitats are observed to manually inspect behaviours and characteristics. Ecologists distinguish this data by observing frequency ranges against time intervals to reveal unique vocalization and behavioural patterns of animals (Putland, et al., 2017).

All human hearing, whether listening naturally or to a recording, is based on frequencies and energy. Across the standard audible frequencies, of 20Hz to 20KHz, most of the sounds we typically hear only exist within a portion of this range. For example, the human voice ranges between 200-6000Hz for an adult male and 400-8000Hz for an adult female voice. Across the overall spectrum, frequencies are logarithmic, meaning for every time a frequency doubles, the pitch goes up an octave. To put this into context, human hearing ranges ten octaves while human speech covers only five octaves.

In the second method explored in this paper, the frequencies of sound recordings taken from this experiment are monitored using spectrograms, between the audible range of 20Hz to 20KHz. This visualizes sound at band widths of 1000Hz and highlights the energy of sounds at any point of time in the recording as seen in Figure 4. The scene is blurred with background sounds at the low frequency range, mostly heavy vehicles passing by and a

continuous fountain, yet there are many discrete sounds that appear across the entire frequency range throughout the duration of this recording.

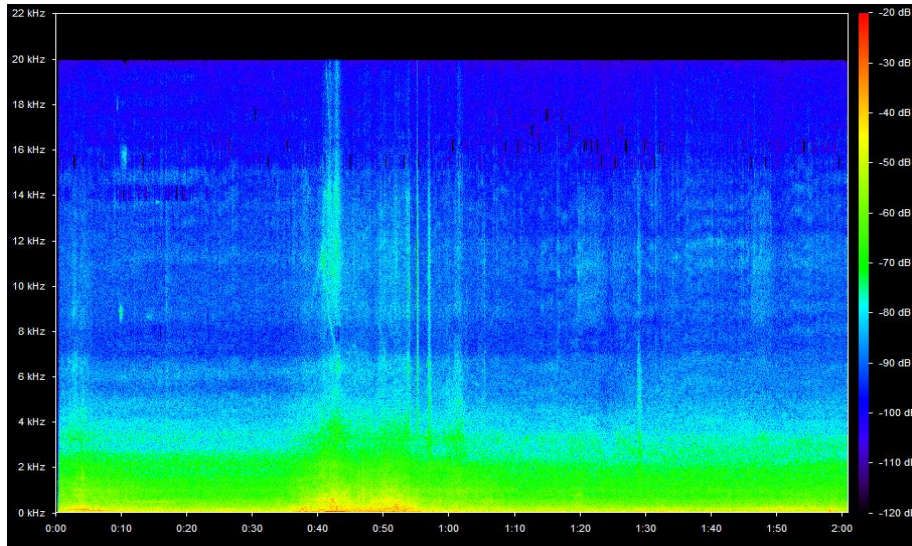

Figure 4. Spectrogram graph of the two-minute recording taken from scene 1B.

3.4. 3D MODELLING

The next representation method of the sonic environment explored involves 3D modelling. Given the advanced capabilities that both designers and computers have today in 3D modelling, this research heavily invests in such methods. A major aspect involves sonification tools, that allow the designer to listen to multiple sound signals imported, as .wav files, directly into the spatial model. Two of the Sydney CBD case studies visited in 2.1 are modelled, including the ANZAC Memorial, Elizabeth Street, and Town Hall Square, George Street, and the observed sounds collected on site are simulated into the model, as seen in Figure 5. Also relevant is the modelling of the site's surroundings, their surfaces, and the absorption co-efficient of each surface.

This is essentially a reconstruction of the sites visited and the designers recorded experience of the sonic environment there. It involves placing the listeners location into the model and the various individual sounds, which can be as specific as a bird flapping or a conversation between two people or a recording of a sound scene, such as a busy urban road.

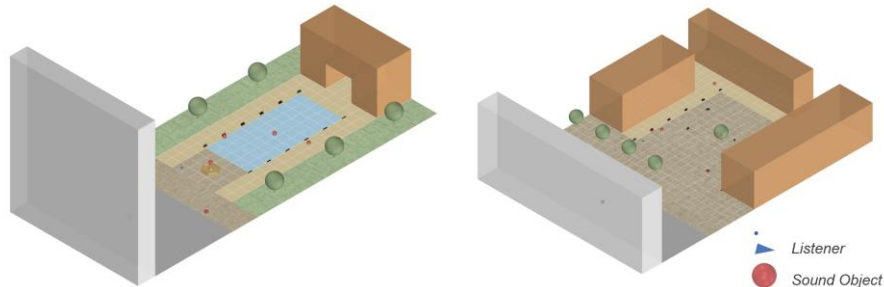

Figure 5. Two sites explored in 2.1, ANZAC Memorial, Elizabeth St (left) and Town Hall Square, George St (right), are modelled with their spatial characteristics, sound locations, and the listeners location at the site.

3.4.1. Sonification

Using sonification, or an available auralization software, allows the designer to revisit their site study within the 3D model. Using an existing software, Esquis'Sons!, multiple sound objects and sources are placed within the model, as well as the listener's position and view. This allows the user, as the listener, to test and distinguish the simulated sonic environment at different locations and with different sounds in the model. For example, it could be obvious from a certain location that a fountainhead is the most dominating and continuous sound, and masks almost all other high-frequency sounds placed also in the model. Listening alone, however, does not recreate the full sonic experience here as the previously recorded parameters in 3.1 lack any representation.

3.4.2. Visualization

The model then implements a simplistic graphical representation for each sound object. Firstly, sounds are distinguished as those that are direct, or local, and those that are ambient, or are heard in the background. Direct sounds are displayed as a sphere, and ambient sounds are displayed as a rectangular prism that 'fills' a volume within the model to its perceived extents. The graphic display of each sound is characterized by its perceptual-based parameters, including the sounds category, dominance, and loudness, represented by the sphere, or box's, colour, size and opacity, respectively; and physical-based parameters, such as the sounds frequency or amplitude, as outlined in Figure 6. Data based on sound perception is extracted from the initial sound listening tasks in Section 2.1, while the frequency or amplitude of each sound is extracted from each individual sound wave using a Fourier transform and reflected in the sphere, or box's, dimness over time.

A HUMAN-CENTRED FRAMEWORK FOR SONIC MAPPING

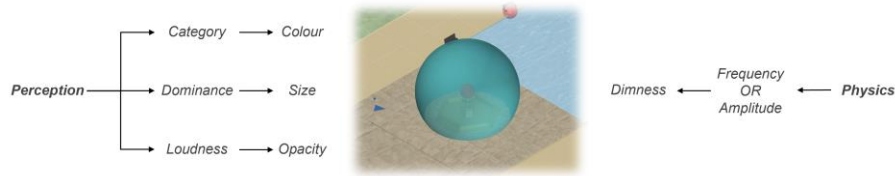

Figure 6. The graphic display of each sound is characterized by its perceptual-based parameters, including the sounds category, dominance, and loudness; and physical-based parameters, such as the sounds frequency or amplitude.

3.4.3. Fourier Transforms

A Fourier transform can be performed on an audio signal from sound waves to represent or graph a sound wave over a time or frequency domain. Take for instance, a .wav file of a bird chirping. In a single second, the length of the recording, the sound wave is represented in a single linear direction, and against a single value, typically the amplitude or frequency of the audio signal across that single second. Even a listener from a non-specialist background will find such a graph simple to understand and relate the graphic values to the characteristic of a bird chirping, but even a professional could have difficulties analysing longer lengths of playtime of different signals occurring simultaneously. Extracting the values of this graph, to begin with, into a list that represents the value, i.e. amplitude, at each time segment, can then be translated into an even more graphical representation. Plugging this data into the 3D model, already explored in 3.4.2, the same audio signals are each represented with a Fourier transform against their amplitudes or frequencies.

4. Discussion: As a Tool for Peoples

These spatial visualizations assist in understanding the complex two-dimensional data of the physical sound wave, by contextualising acoustic values in the spatial model. While the sonification tool is helpful to ‘listen’ to multiple sounds and to the architecture’s response to the sound scene, the spatial visualization has the potential to better inform the observer of certain sound characteristics that are too difficult to comprehend in 2D graphs. While the first two methods explored in this paper, taxonomies and graphs, are useful tools for displaying compacted data taken from the urban environment, they both present a dilemma – neither can speak of the site itself, whether sonically or spatially. The development of representation using 3D models, can therefore continue to explore a combination of the sonification tool and spatial visualization of individual sounds, further completing the audio-visual representation of the environment. For instance,

the designer can have access to an immersive tool that is complete with data to make real-time design decisions that are crucial to the simulated sonic experience.

4.1. SOUNDSCAPE DESIGN PROCESS

The soundscape design process is summarized by Brown (2012) in three stages. The first stage, is defining and analyzing the existing soundscape, where *wanted* and *unwanted* sounds are identified; the second stage, is where alternative soundscape scenarios are designed and planned based on the initial analysis of the existing soundscape; and the third stage, implements the final soundscape design after the different alternative solutions are tested and evaluated. Throughout this design process, the soundscape can be evaluated in *real* or *reproduced* sonic environments. A real sonic environment is recorded and tested in-situ using field study methods, including soundwalks and behavioural observations, however these can be limited to short-term recordings (Kang et al., 2016). The reproduced sonic environment is typically constructed from in-situ recordings of the real environment. Where the real environment is not available or does not exist yet, the environment can be simulated. In addition, the recordings of real sounds can be synthesized alongside simulated sounds at the soundscape design stage. The latter method which reproduces the real sonic environment into a virtual representation is beneficial to review a long-term evaluation of the soundscape. However, real sonic recordings and evaluations contribute to the most realistic representation of the existing soundscape.

Alternatively, representations of the virtual sonic environment can be utilised to simulate more specific factors, from humidity to wind speed. In a real context, recordings of such factors are generally limited to the specific context, leaving researchers little room to test and investigate many variables. No matter the case there are advantages and disadvantages, while in a virtual sonic environment data can be obtained in larger volumes, an absence of physical contact with the spatial and the individual cognitive experience can be criticised. In summary, this explores the practice of sound listening, as both a qualitative and quantitative study and how it can be broken down and wired to a framework to analyze the sonic environment. This would potentially lead to a framework for design as a means of allowing architects and designers to implement their configuration choices and treatments to the urban environment. Users can decide on or change parameters based on spatial patterns while the system updates the simulations or visualizations of the sonic results. Representations of this kind offer a symbiosis of visualizing and experiencing the environment we inhabit, contributing to an appreciation of positive experiences by encouraging an engagement with such tools. Human-centered analysis creates an empathy with the people we are designing for. The solely visual

representation of the design process is currently out of touch with the environment and living conditions of humans. It is because of this reason that designers should develop ways towards a holistic approach that can communicate the qualities of the environment to the end user, and in turn, place the end user at the centre of the design workflow, delicately balancing the built environment with the overlap of daily activities.

5. Conclusion

The scope of this research is partly about archiving different representations of sound, as well as reviving these representations. The goal is about representation - a bridge between lay people and sound studies. The implementation of environmental analysis in architectural design, already evident in its understanding of wind, air control, and lighting, is lacking in studies of sound. For the lay person, representation, being crucial to the perceptive awareness of the key features of the environment (whether climatic, sonic, solar, etc.), can benefit from a computational design model. This can be incorporated to construct the sonic and spatial qualities of an environment, which in turn shape our recognition and experience of these qualities. A representation of this kind offers a symbiosis of visualizing and listening to the environment we inhabit, contributing to an appreciation of positive sonic experiences by encouraging natural listening. The designer is also faced with opportunities to explore new typologies or exploring past typologies that enhance the acoustic signature of an environment. This can be developed in an indoor or outdoor context, or in the perspective of this research, around the threshold between indoors and outdoors to diversify and enrich our listening experience of the soundscape.

References

- BROWN, A.L., 2012. A review of progress in soundscapes and an approach to soundscape planning. *International Journal of Vibration and Acoustics*, 17, 73–81.
- KANG, J. ALETTA, F. GJESTLAND, T.T. Brown, L.A. BOTTELDOOREN, D. SCHULTE-FORTKAMP, B. LERCHER, P. VAN KAMP, I. GENUIT, K. FIEBIG, A.E. LUIS BENTO COELHO, J. MAFFEI, L. AND LAVIA, L., 2016. Ten questions on the soundscapes of the built environment. *Building and Environment*, 108, 284-294.
- PIJANOWSKI, B.C. FARINA, A. GAGE, S.H. DUMYAHN, S.L. AND KRAUSE, B.L., 2011. What is soundscape ecology? An introduction and overview of an emerging new science. *Landscape Ecology*, 26, 1213–1232.
- PUTLAND, R.L. CONSTANTINE, R. AND RADFORD, C.A., 2017. Exploring spatial and temporal trends in the soundscape of an ecologically significant embayment. *Scientific Reports*, 7 (1), 5713.
- SCHAFFER, M., 1977. *The Soundscape: Our Sonic Environment and the Tuning of the World*. New York: Destiny Books.

D2.P2.S2

HUMAN-COMPUTER INTERACTION II

HUMAN-COMPUTER INTERACTION FOR URBAN RULES OPTIMIZATION

ALIA BELKAID, ABDELKADER BEN SACI

Carthage University, National School of Architecture and Urbanism, ED SIA, M2A, 2026. Sidi Bou Saïd, Tunisia.

Email address: a.belkaid@gnet.tn

Grenoble Alpes University, CNRS, School of Architecture, AAU-CRESSON, 38000 Grenoble, France.

Email address: bensaci.a@grenoble.archi.fr

AND

INES HASSOUMI

Tunis University, ISG, SOIE-COSMOS, Tunisia

Email address: ines.hassoumi@gmail.com

Abstract. Faced with the complexity of manual and intuitive management of urban rules in architectural and urban design, this paper offers a collaborative and digital human-computer approach. It aims to have an Authorized Bounding Volume (ABV) which uses the best target values of urban rules. It is a distributed constraint optimization problem. The ABV Generative Model uses multi-agent systems. It offers an intelligent system of urban morphology able to transform the urban rules, on a given plot, into a morphological delimitation permitted by the planning regulations of a city. The overall functioning of this system is based on two approaches: construction and supervision. The first is conducted entirely by the machine and the second requires the intervention of the designer to collaborate with the machine. The morphological translation of urban rules is sometimes contradictory and may require additional external relevance to urban rules. Designer arbitration assists the artificial intelligence in accomplishing this task and solving the problem. The Human-Computer collaboration is achieved at the appropriate time and relies on the degree of constraint satisfaction with fitness function. The resolution of the distributed constraint optimization problem is not limited to an automatic generation of urban rules, but involves also the production of multiple optimal-ABV conditioned both by urban constraints as well as relevance, chosen by the designer.

Keywords: *Artificial intelligence, Multi-agent system, Fitness function, Authorized Bounding Volume, Distributed constraint optimization, Human-computer interaction, Urban rules.*

ملخص. في مواجهة تعقيدات الإدارة اليدوية والبيديهية للقواعد الحضرية في التصميم المعماري والحضري، تقدم هذه الورقة البحثية نهجًا تعاونيًا ورقمياً بين الإنسان والحاسوب. يهدف هذا النهج إلى الحصول على حجم إحاطة مصرح به (ABV) يستخدم أفضل القيم المستهدفة للقواعد الحضرية، وهي عبارة عن مشكلة توزيع القيد الأمثل. يستخدم نموذج ABV التوليدي أنظمة متعددة الوكلاء. ويوفر نظامًا ذكيًا للتشكيل الحضري قادرًا على تحويل القواعد الحضرية على قطعة أرض معينة إلى تحديد مورفولوجي تسمح به لوائح التخطيط للمدينة. يعتمد الأداء العام لهذا النظام على نهجين: البناء والإشراف، الأول يتم إجراؤه بالكامل بواسطة الآلة والثاني يتطلب تدخل المصمم للتعاون مع الآلة. تكون الترجمة المورفولوجية للقواعد الحضرية أحيانًا متناقضة وقد تتطلب علاقة خارجية إضافية بالقواعد الحضرية. ويتم الاستعانة بالتحكيم المصمم مع الذكاء الاصطناعي في إنجاز هذه المهمة وحل المشكلة. يتم تحقيق التعاون بين الإنسان والحاسوب في الوقت المناسب ويعتمد على درجة رضا القيد عن دالة الملاءمة. لا يقتصر حل مشكلة تحسين القيد الموزع على إنشاء تلقائي للقواعد الحضرية، ولكنه يتضمن أيضًا إنتاج العديد من ABV الأمثل المشروط بالقيود الحضرية وكذلك الملاءمة التي يختارها المصمم.

الكلمات المفتاحية: *الذكاء الاصطناعي، النظام متعدد الوكلاء، دالة الملاءمة، حجم إحاطة مصرح به، استمثال قيود موزع، تعاون بين الإنسان والحاسوب، القواعد الحضرية.*

1. Introduction

Actually, urban rules occupy a crucial place in architectural design as well as in urban manufacturing. Many buildings have proved this. In New York, several building forms are described by Reem Koolhaas (1997) as “generated” forms, such as « Flatiron Building » (1902). The « Prada » building (2003) in Tokyo also complies with urban rules and adopts the principle of «Take zoning as a design guideline » (Lucan, 2009).

Given the complexity of the manual and intuitive management of urban rules (case of the projects mentioned above), several digital approaches have emerged in various fields of application. The first field is urban planning with morphological simulation (Gil and al., 2010) of urban rules. To meet this need, two selected software tools are currently available on the market: CityCAD (2020) and CityEngine (2020).

The second field of application is the evaluation of the spatial feasibility of an architectural program in a given urban situation (Stone & Wilcox, 1988; Yang & Robertson, 1995). This paper is interested in a third field of application related to digital assistance for the management of urban rules from the first moments of architectural design. The research that aims at the generation of constructible shells has used several types of techniques and technological processes: the declarative approach (Faucher, 2001), pseudo-genetic algorithms (Salieri et al., 2009) and the simulated annealing method (Brasebin, 2017).

However, all these tools focus on regulatory compliance without trying to reach its optimal limits. This leads to think about a new approach of decision support system that opens the possibility for a human-machine collaboration. This paper's target is to address the issue of regulatory optimization, which aims to generate volumes that best reflect the target values of urban rules. This embodies a problem of distributed constraint optimization (DCOP for Distributed Constraint Optimization Problems). Its resolution is not limited to an automatic morphosis of urban rules but calls on the designer. The solution to this problem is an optimal constructible volume, called "Authorizing Bounding Volume" (ABV).

Thus, this paper asks the following questions: How to generate a regulatory encompassing volume based on the resolution of distributed constraint optimization problems? How does human-machine interactivity work ?

In response to these challenges, firstly we start with the multi-agent approach for ABV generation (Sect.2). It will be followed by the Optimization of regulatory volume constraints (Sect.3). Then, we will develop the designer's share of assistance in the management of morphological urban rules (Sect.4). Finally, we will present the results of an experiment (Sect.5), which will be discussed (Sect.6) for the validation of the approach.

2. Multi agent approach for ABV generation

We notice that the paradigm and technological advancement influence the results of digital assistance tools. For this reason, we have chosen to explore the agent-oriented approach which has proven itself in the management of complex situations at different spatial scales (Ferber, 2006). MAS are an extension of classical object-oriented artificial intelligence (Steven and al., 2019). These systems present several interacting agents that can manipulate constraints to achieve an overall objective (Ferrand & al., 1998). For this reason, the principle of interaction and cooperation of this approach seems appropriate to overcome the complexity of managing urban rules which become constraints. In addition, the MAS can give a place to the human (considered as agent) in the design activity and in the generative actions of the ABV which is deployed in the urban space.

In response to the multitude of multi-agent approaches, Ferrand et al. developed a generic model called "Reactive Multi Agent System to Spatial Problem-Solving" (RMASSPS). This approach applies to the class of problems whose phenomenon takes place in the euclidean morphic space as is the case of the ABV generation problem. It aims to build entities called "reactive agents" that will interact with each other on the one hand, and with internal and external constraints on the other, and will thus evolve collectively to converge towards a spatial organization representative of a

solution (Ferrand & al.). Referring to RMASSPS, the ABV Generative Model consists of four entities: agents, environment, interactions and organization. It incorporates internal urban constraints and external constraints induced by the designer.

The organization of agents is hierarchical. Thus, this multi-agent system has four levels of agents (Figure 1). A volume-agent has agents that work on its construction. It is decomposed into faces-agent. A face-agent is decomposed into edges-agent. An edge-agent is decomposed into two vertex agents. Functionally, each agent has three functions whose objective is to optimize the topology, shape and size of the ABV. These functions depend on constraints. Each agent can access the attributes of the elements of its environment (E), which is an application of the Urban form (Uf) in a set of attributes (A). During the interaction between the agents and the environment, the values of the internal urban constraints are calculated from the data of the chosen plot. While during the interactions between the agents, the latter exchange the values of their internal urban constraints, which will be associated, when necessary, with the constraints formulated by the designer. The satisfaction of the constraints will be distributed among the components of the multi-agent system.

The ABV Generative Model borrows concepts from the genetic algorithm (Aziza and Krichen, 2020). It begins with initialization of parameters to generate a set of volumes. This generation phase is followed by the evaluation of constraints satisfaction using the fitness function. It gives a score to generated volumes. For each situation assisted by the designer, the ABV Generative Model goes through a phase of selection and then classification of volumes to choose the optimal solution. This process is iterative until the optimum volume is reached. We will detail in the following steps the optimization of internal and external constraints in the ABV Generative Model.

3. Constrained optimization of Authorising Bounding Volume

The problem of optimizing the urban constraints, distributed on agents, requires first the definition of the urban constraints, the initialization of the system, the generation of volumes then their evaluation (Figure 1). These steps will be explained in the following.

3.1. MODEL INITIALIZATION

The ABV Generative Model is based on hierarchical morphological urban rules deduced from a historical study of urban regulations.

The classification of urban rules is based on three criteria (status, frequency, and age) and three concepts (priority, preponderance and importance).

In addition, the ABV Generative Model translates the hierarchical classification of rules by weighting coefficient for each rule. This coefficient is the opposite of the urban rules order application. All of these coefficients feed a parametric initialization table of the internal constraints.

3.2. EVOLUTION AND GENERATION OF VOLUMES

The system begins with the agents' interactions who communicate with each other and with the environment by applying internal constraints. After a given time t , the system generates an ABV which can be a single or multiple spatial solution. This solution depends on the number and nature of the constraints from one city to another. The "unique ABV" solution (Figure 1) is generated by the system without assistance of the designer. This solution is an "optimal ABV" characterized by the total satisfaction of all constraints. However, the "optimal ABV" tries to best meet the target values of the constraints. Thus, the "multiple ABV" solution comprises several "optimal ABV" which are as close as possible to the constraints target values. Note that the "multiple ABV" solution is often conditioned by the assistance of the designer. To evaluate each proposed volume, we propose to use the fitness function (Figure 1).

3.3 ABV EVALUATION WITH THE FITNESS FUNCTION

The evolution of our system results in the generation of volumes with partial or total satisfaction of constraints. This evaluation calculation is done with the fitness function (inspired from genetic algorithms) (Aziza and Krichen, 2020). The fitness function calculates the solution optimization using target values, current values and weighting coefficients of the various constraints. These coefficients can be modified by the designer. The evaluation phase results in two cases.

If the solution is unique, the system shuts down without designer intervention by simply taking a construction approach. If the solution is multiple, the system asks the designer to assist him and find a desired solution (Figure 1). We detail in what follows the operating principle of this human-machine interaction.

4. Human machine interaction

The human-machine interaction represents a space for experimentation of the system which evolves according to an iterative process. The final aim is to converge towards a desired optimal solution. This is the control approach. In this case, the designer dynamically influences the existing multi-agent system (MAS) to direct its overall behavior towards a desired behavior. This approach is based on the topical and disruptive relevance of the designer. The relevance check allows us to choose among the more appropriate solutions according to the designer's point of view. Control by relevance is here an actantial control, based on the designer's selection of the priority and important urban constraints. The designer can introduce topical relevance as an adjuvant agent or disruptive relevance by playing the role of opposing agent. These two types of agents are presented in the following sections.

4.1 ADJUVANT AGENT

In semiotics, an adjuvant actant plays the role of benefactor. It helps in achieving a given goal. The system asks the designer to choose a preferred implantation position for the definition of topical relevance, noted β^+ . That's how the designer plays the role of a "Topical adjuvant". We propose to integrate this notion into the multi-agent system of ABV generation through an adjuvant agent. This agent helps to achieve the overall objective of the system in the case of multiple solutions (Figure 1). This agent chooses the best volume and eliminates the rest of the volumes. This operation is made in order to reduce the number of offered volumes.

4.2 OPPOSING AGENT

In semiotics, an opposing agent acts as a malefactor. It creates obstacles to the achievement of the overall objective. But this actor has a not negligible or even decisive role in the progression of events according to a generative path of the story. By analogy, we propose to integrate an opposing agent who will play the role of a disrupter. At an advanced stage, when multi-agent is unable to achieve an optimal solution alone, the system requires the designer's arbitration by modification of the parametric initialization table. The opposing agent will change the weighting coefficients according to relevance. The goal is to help the system to converge on a desired solution. The relevance introduced by the architect would be the purpose of the rule or package of priority rules. Relevance defines the distinctive character of the ABV. The parametric initialization table remains open to any disturbance made by the designer.

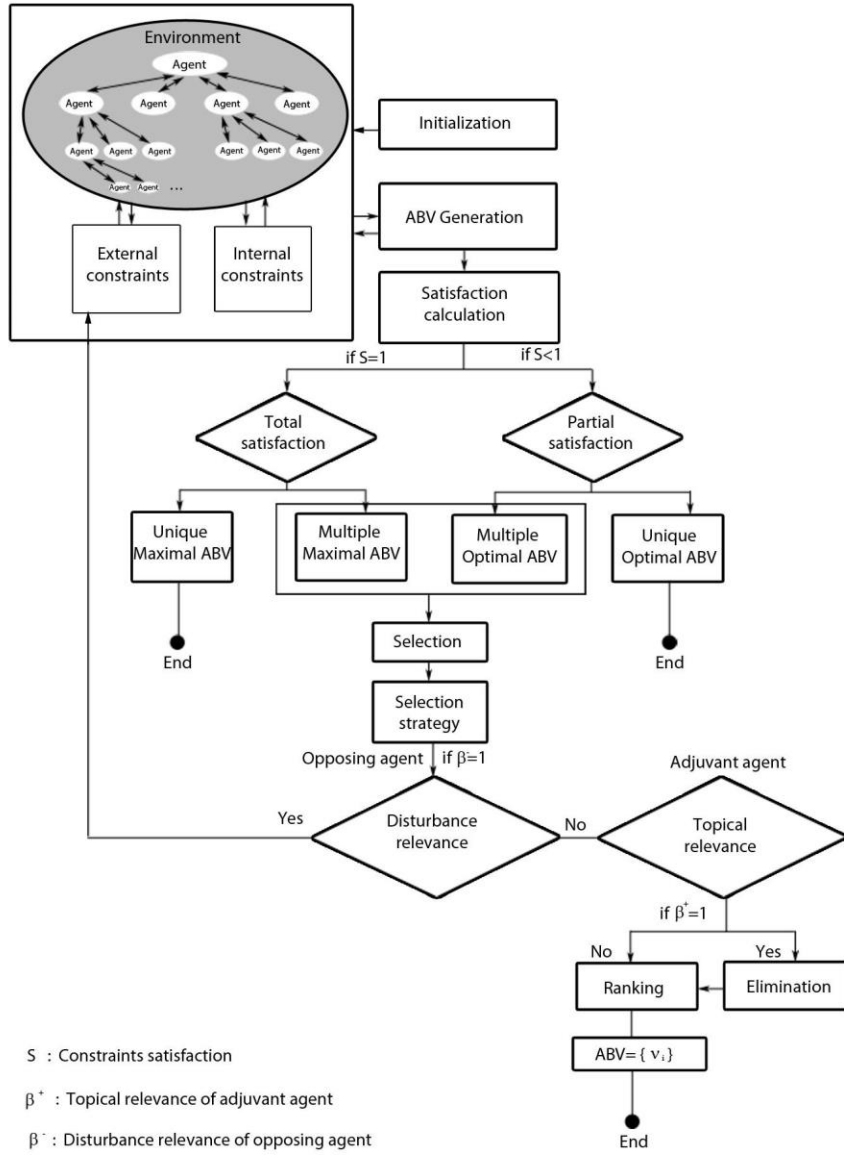

Figure 1. ABV Generation Model

5. Results

We propose to experiment the ABV Generative Model on a plot located in Tunis with the NetLogo 3D platform. We take into account seven constraints applied to this plot: alignment, setback from roads, maximal height, setback from common limits, servitude of view, constructability context and the Building Coverage Ratio (BCR).

After having introduced the shape of the chosen plot on the NetLogo 3D platform, we propose to study a case of human-machine interaction. We choose a case where the designer, as an opposing agent, will select constraints considered as priorities. It will thus disturb the sample weights of the parametric initialization table. The goal orients the system towards a desired solution. In this case, the designer favors a set of constraints by assigning it the maximal sample weights (equal to 1) in order to look for the ecological ABV.

The designer aims for a compact and slender ABV, which respects solar access constraints. In this case, he prefers the following constraints: maximal height, the alignment prospect and the setback common limits.

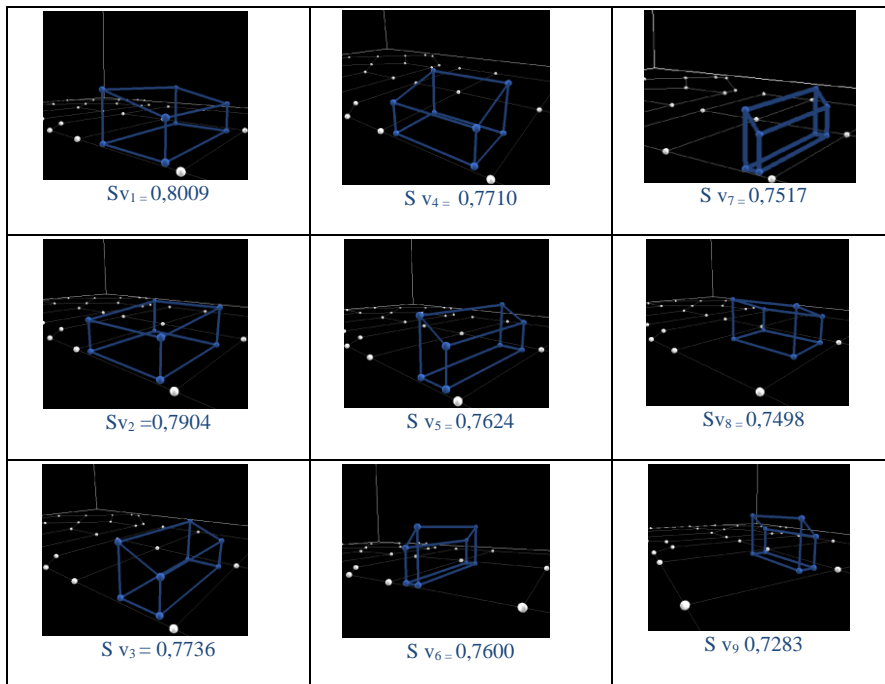

Figure 2. Classification of volumes

The calculating of constraint satisfaction is applied here according to the choice of the designer. To meet the designer's relevance, we consider the three positions of the ABV (right, bottom and top). This application makes it possible to obtain a multiple-ABV composed of 9 volumes (v_j) with different values of constraint satisfaction ($S v_j$). The system then classifies all the volumes (v_j) according to their performance: from the optima-volume ($Sv1=0,8009$) to the volume having the lowest satisfaction of the constraints ($Sv9=0,7283$) (Figure 2). The ABV which has the best value of satisfaction of constraints equal to 0,8009 (and a satisfaction rate equal to 80,09%) is positioned to the right of the plot with a maximum BCR value (equal to 0,5). The ABV with the lowest satisfaction value equal to 0,7283 (and a satisfaction rate equal to 72,83%) is positioned at the top with a minimum BCR value. The generated volumes positioned at the top of the plot with different BCR values have the lowest values of constraint satisfaction.

6. Discussion

During this experiment, the optima-ABV solution requires collaboration with the designer. The ecological relevance of the designer helped the system to converge towards desired solutions. The ABV Generative Model thus helps the designer make a decision by offering him the best volumes compared to his given point of view.

For its convergence, the system needs the conditions and strategies in order to generate a desired solution: definition of a step of constraint variation, the choice of and the fixing of the iteration time.

Nevertheless, the same volume generated has different constraints satisfaction values depending on the relevance considered by the designer. We can see that the calculation of satisfaction of constraints is relative. It depends on the designer's willingness to reduce the number of solutions according to his wishes. For example, the same volume can have $S1$ satisfaction from an ecological point of view and $S2$ satisfaction from a security point of view.

It is possible to formulate several types of relevance during human-machine collaboration. The volumes generated are compared only with a given relevance. Nevertheless, the comparison of the standard deviations, measuring the dispersion of the constraint satisfactions according to different relevance, informs us about the best character of the ABV. The volumes generated, which have the lowest standard deviation with the satisfaction of the highest maximum constraints, correspond to the best relevance.

7. Conclusion

We have presented in this work an ABV Generative Model for aided decision. This model is based on a multi-agent system and an optimization approach based on the fitness formula. The choice of multi-agent systems is that they allow the integration of quantitative variables, differential equations and rules-based behaviours into the same modeling.

The ABV can be used by the architect upstream of the architectural design to manage and integrate urban rules in the development of solid drafts. The architect can thus develop spatial proposals inside an ABV and verify, during the design activity, compliance with urban rules.

The ABV is the building volume, which optimizes the urban constraints as well as possible. Optimization is based on a hierarchy of rules (internal constraints) and the desires of the designer (external constraints) to achieve "desired solutions". This model does not pretend to automate architectural design, but rather develops the interaction between designer and machine as needed. The contribution of this paper lies in the proposal of a human-machine interaction strategy that plays the role of a digital medium to help the generation of optimal building volumes. The designer interacts with the machine in the case of a multiple-ABV in order to converge the system towards a desired solution. Thus, it helps the machine to reduce the number of generated volumes and to end up with a classification according to a chosen.

Therefore, the urban rule can become a source of invention, far from being simply a source of restriction. Although the modeling is limited here to the generation of urban constraints, the approach could be extended to other types of constraints (visibility, ventilation, sound sources, etc.) of different cities in the world.

References

AZIZA, H. KRICHEN, S., 2020. *A hybrid genetic algorithm for scientific workflow scheduling*. In Cloud Environment. Springer-Verlag London Ltd., part of Springer Nature.

BRASEBIN, M., PERRET, J. AND REUILLON, R., 2017. *Stochastic Buildings Generation to Assist in the Design of Right to Build Plans*, *Advances*. In 3D Geoinformation, Springer International Publishing, 373-384.

CityCAD (2020). <https://www.holisticcity.co.uk/services/citycad/>

CityEngine (2020). <https://doc.arcgis.com/en/cityengine/latest/whats-new/cityengine-whats-new.htm>

FAUCHER, D., 2001. *URBANLAB : modélisation déclarative des enveloppes urbaines réglementaires*. Thèse de doctorat. Nantes : Université de Nantes.

HUMAN-COMPUTER INTERACTION FOR URBAN RULES OPTIMIZATION

FERBER, J., 2006. *Concepts et méthodologies multi-agents*. In F. Amblard, D. Phan, *Modélisation et simulation multi-agents : Application pour les Sciences de l'Homme et de la Société*. Hermès. 23–47 pages.

FERRAND, N., DEMAZEAU, Y., & BAEIJS, C., 1998. *Systèmes Multi- Agents Réactifs pour la Résolution de Problèmes Spatialisés*. *Revue d'Intelligence Artificielle*, 12 (1), 37-72.

GIL, J., BEIRÃO, J., MONTENEGRO, N., & DUARTE, J. ,2010. *Assessing computational tools for urban design : Towards a “City Information Model”*. In G. Schmitt, & al., *Future Cities* (pp. 316-324). ETH Zurich : 28th eCAADe Conference Proceedings.

KOOLHAAS, R., 1997. *Delirious New York : A Retroactive Manifesto for Manhattan* : The Monacelli Press.

LUCAN, J., 2009. *Composition, non-composition : Architecture et théories, XIXe-XXe siècles* (Presses polytechniques et universitaires romandes, Lausanne).

NetLogo 3D <https://ccl.northwestern.edu/netlogo/docs/3d.html>

SALERI, R., FONS, E., JANDA, M., & KIESGEN, R., 2009. *Génération Interactive Evolutionnaire appliquée aux designs urbain et architectural : le projet URBAG*. In B. J-C., & al., *Conception architecturale numérique et approches environnementales* (pp. 47-59). Nancy : Presses universitaires de Nancy.

STEVEN, J. Q., JAMES P., ATHANASSIOS E. AND SUGIE, L., 2019. *Artificiel Intelligence-Aided Design : Smart Design for Sustainable City Development*, *Environment and Planning B : Urban Analytics and City Science Journal* 46, 1581-1599.

STONE, D., & WILCOX, D., 1988. *Intelligent information systems for building standards*, *Proceedings of Europ'IA 88 Journées Européennes sur les applications de l'intelligence artificielle en architecture, bâtiment et génie civil*, pp. 299-313.

YANG, S., & ROBERTSON, D., 1995. *A case based reasoning system to support the relaxation of building regulations*. *The international Journal of Construction Information Technology* , 3 (2), 29-48.

FILL IN THE BLANKS

Deep Convolutional Generative Adversarial Network to Investigate the Virtual Design Space of Historical Islamic Patterns

MOSTAFA W. ALANI, BILAL R. AL-KASEEM

Al-Iraqia University

Email address: mostafa.waleed@aliraqia.edu.iq

Email address: bilal.al-kaseem@aliraqia.edu.iq

Abstract. This paper presents a method to explore the virtual design space of historical Islamic Geometric Patterns (IGP). The introduced approach utilizes Deep Convolutional Generative Adversarial Network (DCGAN) to learn from historically existing hexagonal-based IGP to synthesis novel, authentically looking Geometric Patterns.

Keywords: *Islamic Geometric Patterns, Morphology, Computations, Algorithmic Thinking, Deep Convolutional Generative Adversarial Network*

ملخص. يقدم هذا البحث طريقة لاستكشاف مساحة التصميم الافتراضية للمجسمات الهندسية الإسلامية التاريخية. الطريقة المقدمة تستخدم شبكة خصوميه توليدية عميقة للتعلم من المجسمات الهندسية الإسلامية السداسية الشكل لتوليف أنماط هندسية جديدة وذات مظهر أصيل.

الكلمات المفتاحية: *المجسمات الهندسية الإسلامية ، المورفولوجيا ، الحوسبة ، التفكير الخوارزمي ، الشبكة الخصوميه التوليدية العميقة.*

1. Introduction:

Digital technologies are profoundly changing the way that form is being generated. Instead of being a mere drafting tool, digital technologies are becoming design thinking tools capable of exploring form possibilities and visiting uncharted territories by manipulating design rules and constraints (Oxman and Oxman, 2014; Terzidis, 2006.).

FILL IN THE BLANKS: DEEP CONVOLUTIONAL GENERATIVE ADVERSARIAL NETWORK TO INVESTIGATE THE VIRTUAL DESIGN SPACE OF HISTORICAL ISLAMIC PATTERNS

Artificial Intelligence (AI) brings to the table the ability to learn from existing designs to synthesis new ones using Deep Convolutional Generative Adversarial Network (DCGAN). Thus, the machine becomes able to extract rules and constraints, manipulate them to create something novel. A ‘counterfeit’ that possess the same design characteristics, yet it is not an original design.

The design and research of Islamic architecture need to move beyond the formal compositional aspects and "interrogate" the inner structures of existing forms. Such an approach will allow identifying mechanisms responsible for producing the wide variety of survived designs and reestablishing an "open-ended" search for the forms that ultimately make Islamic architecture an active contributor to contemporary architecture.

2. The Artisan & The Mathematician

The creation of geometry in Islamic culture was significantly informed by mathematics as suggested by historical evidence. Artisans and mathematicians worked collaboratively to develop perfect geometry. In *fī mā yaḥtāj ilayh al-ṣāni‘ min al-a‘māl al-handasiyya* (A book on those geometric constructions which are necessary for a craftsman), Abu 'l-Wafa' al-Buzajani (940-98 CE) discussed—in an accessible fashion—various mathematical approaches to create geometry linking theory to praxis (Figure 1). This manuscript highlights the kind of informed discussions that took place during the Abbasid dynasty between mathematicians and artisans. Al-Buzajani was concerned that the artisans of his time did not have enough ‘adequacy’ in geometric knowledge to create designs without approximation (Özdural, 1995). He wrote:

“In order to create fine works, the artisan has to quit working by the eye-measure.”

Al-Buzajani wasn’t the only mathematician who held such meetings with artisans; 11th-century mathematician Umar Khayyam also held meetings with artisans. Such meetings were held frequently in the 16th and early 17th centuries Istanbul (Özdural, 2000).

The discussions' goals were identifying rules and constraints that artisans need to consider when making these designs. These rules and constraints controlled the type and shape of historical designs. Consequently, manipulating these rules created a wide variety of designs that we have at our disposal today.

When it comes to the Islamic Geometric Patterns (IGP), both periodic and quasi-periodic patterns exist. In general, periodic patterns exhibit four ‘recognizable characteristics’: symmetry, flow, unboundedness, and

interlacing (Abas and Salman, 1994). The periodic IGPs are typically consisting of a *repeated unit* and a *repetitive structure*. The repeated unit is a container that holds several fundamental units. The *fundamental unit* is the minimum geometric motif that is being populated through symmetry (Figure 2). The repetitive structure is generated through the systematic repetition of the repeated unit to fill the space (El-Said et al. 1993). The geometric motifs were manipulated within the fundamental units to create new geometric patterns that propagated to the whole patterns through the repetitive structure.

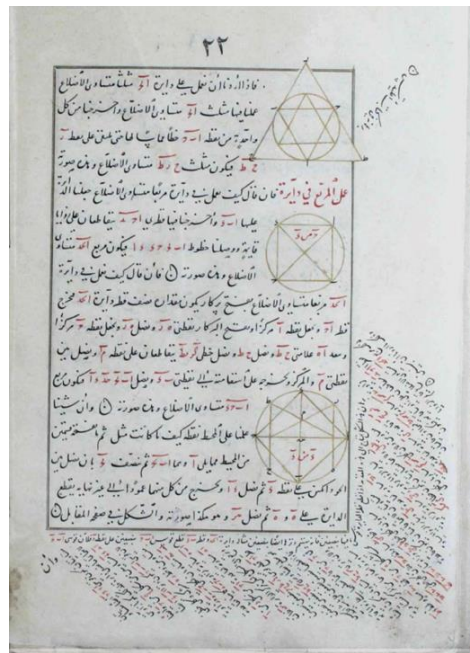

Figure 1. Page from the *fī mā yahtāj ilayh al-šāni ' min al-a 'māl al-handasiyya* (A book on those geometric constructions which are necessary for a craftsman), by Abu 'l-Wafa' al-Buzajani.

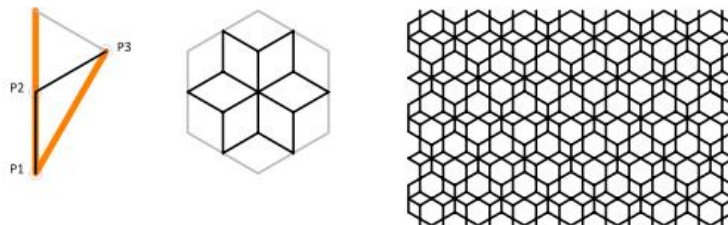

Figure 2. Periodic repetitions of Islamic Geometric Patterns. Left: Fundamental Unit. Middle: repeated unit. Right: repetitive structure.

3. The Machine

Recent advancements in AI and Machine Learning (ML) are significantly transforming the discipline of architecture. The machine is increasingly becoming an active contributor in the design process. The Deep Convolutional Generative Adversarial Network (DCGAN) is an ML architecture based on convolutional neural networks (CNN) that are first introduced by Goodfellow *et al.* in 2014 at the University of Montreal. (Goodfellow, Pouget-Abadie, Mirza, Xu, Warde-Farley, Ozair, Courville, and Bengio, 2014). GAN performs unsupervised learning tasks to generate new plausible features that have been gained from the original dataset when learning the existing pattern that is available in the input dataset.

The DCGAN utilizes two models that simultaneously generate designs and validate the generated designs: the generator and the discriminator. The generator attempts to create designs that highly reflect the provided data by learning the existing patterns from the provided data. The generator is trained to capture the real data distribution for generating or producing new examples from the problem domain that can be as real as possible.

In contrast, the discriminator attempts to classify the newly generated data instances as either real (belongs to the actual training dataset) or fake (generated). As in the game theory scenario, the generator CNN must pit versus an adversary CNN until the generator model progressively improves and generates novel yet authentically looking designs (Figure 3).

Figure 3 shows the proposed DCGAN architecture that is used in this work to generate new geometrical patterns from the available pattern that existed in the training dataset. The introduced approach of DCGAN can be summarized as follow: 1) The generator model accepts random numbers and produces an image, 2) the image generated in step 1 is sent to the discriminator with a stream of actual images belongs to the actual training dataset, 3) the discriminator model compares the real and the generated images to evaluate the probability of authenticity that is between 0 for fake image and 1 for the authentic image, 4) Feedback loops are used to enhance the model performance based on the comparison in step 3. The discriminator model will be in a feedback loop with the actual training dataset and also the generator model will be in a feedback loop with the discriminator model, 5) the execution

continues to run until a stop condition is met (reaching the desired model accuracy or reaching the maximum number of epochs).

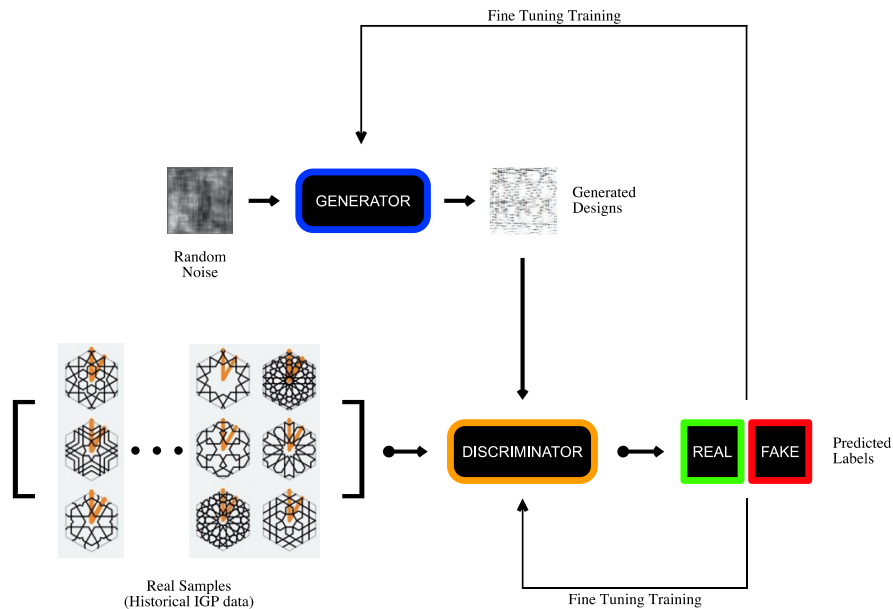

Figure 3. The proposed DCGAN architecture

4. Research Framework & Methodology:

The hexagonal based Islamic Geometric Patterns (IGP) can be classified based on the polylines count within the fundamental units into six morphological groups. This morphological classification of hexagonal based IGP reveals gaps in the currently existing survived designs. The analysis of inner structural arrangements shows that the design methodology itself can fill all of the morphological groups, yet no actual cases were identified in some groups (Figure 4) (Alani, 2018). The underlying theoretical framework of this research is based on the writings of French philosopher Gilles Deleuze, that is, designs we observe in reality are actualized statuses of an idea, and that is the generative process is capable of creating other design possibilities of what Deleuze's calls virtual designs. Therefore, through learning from data, the DCGAN attempts to identify the generative process that captures the virtual design space of IGP and use that process to create authentically looking, novel singularities (Deleuze, 1993 & 1994).

FILL IN THE BLANKS: DEEP CONVOLUTIONAL GENERATIVE
ADVERSARIAL NETWORK TO INVESTIGATE THE VIRTUAL DESIGN
SPACE OF HISTORICAL ISLAMIC PATTERNS

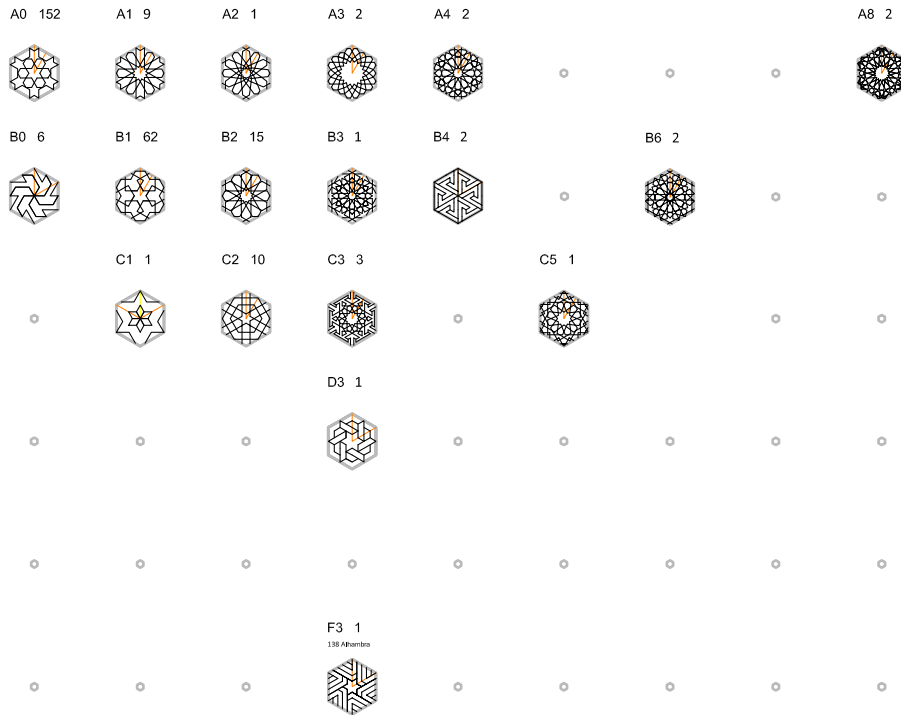

Figure 4. Morphological grouping of historical Hexagonal based Islamic Geometric Patterns that highlight the morphological gaps.

5. Data Collection:

This research focuses on periodic IGP; more specifically, this research concentrates on hexagonal based IGP and employs purposive sampling that tracks survived design in various regions of the Islamic world bounded by the chronological periods of ninth to the 15th century as this era identified as the “period of invention” (Abas and Salman, 1994).

The total number of collected data that has been employed in this experiment is 273 designs. All of the data were collected in digital photographs and converted to CAD vectors to control for color and other embellishments techniques and to explore the geometric design space solely. The repeating unit of each design was isolated in a hexagonal cell and stored in a PNG file format and then uploaded to the cloud to be fed to the DCGAN.

6. Experiment & Preliminary Results:

The hexagonal cells of the 273 collected historical designs were fed to the DCGAN. Two neural networks were utilized simultaneously to generate hexagonal patterns from scratch and validate the authenticity of the generated designs. The generator started by creating an image from random noise. The image then sent to the discriminator, which, in its turns, reports the probability of this image is real. The generator progressively gets better. The hexagonal cell that represents *repeated units* started to shape early in the process. In addition, the resulted images have increasingly begun to show branching lines instead of random noise and reflect some of the “recognizable characteristics” of IGP. Symmetry and interlacing became the dominant feature of the generated pixel noise (Figure 5).

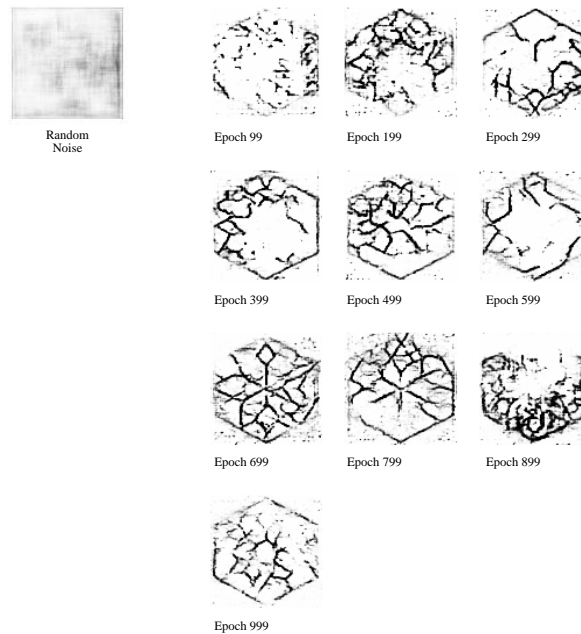

Figure 5. Left: random noise generated as a starting point for creating hexagonal geometric designs. Right: GAN generated results sampled every 100 epochs.

FILL IN THE BLANKS: DEEP CONVOLUTIONAL GENERATIVE
ADVERSARIAL NETWORK TO INVESTIGATE THE VIRTUAL DESIGN
SPACE OF HISTORICAL ISLAMIC PATTERNS

7. Discussion:

Ancient artisans and mathematicians developed a process of design that was capable of exploring the virtual design space of IGP. As a result, the survived corpus of work shows an enormous diversity of designs. Yet, the morphological analysis of IGP revealed the existence of gaps. It is possible that these gaps are the result of a loss or never thought of designs. Both cases could be considered an opportunity to explore the possibility to either restore what is missing or to produce novel designs and visit 'uncharted territories.' This paper presents a method to explore the virtual design space of historical IGP using DCGAN. Thus, the presented method is utilizing mathematics and morphology to actively engage the design of Islamic architecture to construct a version of history that is not only a reminisce of historical designs but also can be considered as a progressive engagement of the design process and a continuation of the legacy of the ancient artisans and Mathematicians.

References

- ABAS, S.J. AND SALMAN, A.S., 1994. Symmetries of Islamic geometrical patterns. World Scientific.
- ALANI, M.W., 2018. Algorithmic investigation of the actual and virtual design space of historic hexagonal-based Islamic patterns. *International Journal of Architectural Computing*, 16(1), pp.34-57.
- DELEUZE, G. 1994, *Difference and repetition*, Columbia University Press.
- DELEUZE, G. 1993, *The fold: Leibniz and the Baroque*, U of Minnesota Press.
- EL-SAID, ISSAM, TAREK EL-BOURI, AND KEITH CRITCHLOW. *Islamic art and architecture: the system of geometric design*. Garnet Pub Ltd, 1993.
- GOODFELLOW, I., POUGET-ABADIE, J., MIRZA, M., XU, B., WARDE-FARLEY, D., OZAIR, S., COURVILLE, A. AND BENGIO, Y., 2014. Generative adversarial nets. In *Advances in neural information processing systems* (pp. 2672-2680).
- TERZIDIS, K., 2006. *Algorithmic architecture*. Routledge.
- OXMAN, R. AND OXMAN, R. EDS., 2014. *Theories of the Digital in Architecture* (Vol. 99). Abingdon: Routledge.
- ÖZDURAL, A., 1995. Omar Khayyam, mathematicians, and "conversazioni" with artisans. *The Journal of the Society of Architectural Historians*, 54(1), pp.54-71.
- ÖZDURAL, A., 2000. Mathematics and arts: Connections between theory and practice in the medieval Islamic world. *Historia mathematica*, 27(2), pp.171-201.

GENERATIVE DESIGN METHODOLOGY FOR DOUBLE CURVED SURFACES USING AI

AHMED HASSAB, SHERIF ABDELMOHSEN

American University in Cairo

Email address: ahmedhassab@aucegypt.edu

Email address: sherifmorad@aucegypt.edu

AND

MOHAMED ABDALLAH

Cairo University

Rac34ah@yahoo.com

Abstract. Despite recent approaches to generate unique surfaces using generative design algorithms, there are still challenges including teaching machines how to learn and manipulate surfaces, thus generating novel and unique versions, and exploring possible alternatives in producing unique surfaces using artificial intelligence. This paper proposes a generative design approach using AI. We propose a generative design methodology for producing novel and unique surfaces by faking input surfaces using artificial intelligence networks. This workflow is applied to two different artificial networks: (1) CycleGAN, (2) Pix2Pix and Augmentor. This experimentation is introduced to apply two real surfaces generating two fake surfaces as a unique version through the networks. Upon running the CycleGANs, Pix2Pix, and a Grasshopper script, the experiment results demonstrated how the proposed generative design methodology using AI produced a unique surface version with a higher level of manipulation and result control.

Keywords: *Generative design, CycleGAN, Pix2Pix.*

ملخص. على الرغم من الأساليب الحديثة لتصميم أسطح فريدة باستخدام الخوارزميات، لا تزال هناك تحديات بما في ذلك تعليم الآلات كيفية التعلم والتعامل مع الأسطح، وبالتالي إنشاء إصدارات جديدة وفريدة من نوعها، واستكشاف البدائل الممكنة في تصميم أسطح فريدة باستخدام الذكاء الاصطناعي. تقترح هذه الورقة البحثية نهج التصميم التوليدي باستخدام الذكاء الاصطناعي. نقترح منهجية تصميم توليدي لإنتاج أسطح جديدة وفريدة من نوعها عن طريق شبكات الذكاء الاصطناعي. يتم تطبيق سير العمل هذا على شبكتين

GENERATIVE DESIGN METHODOLOGY FOR DOUBLE CURVED SURFACES USING AI

اصطناعيتين مختلفتين CycleGAN (1) : Pix2Pix (2). تمت هذه التجربة علي سطحين ليولدا سطحين جديدين كنسخة فريدة من خلال الشبكات. وأوضحت نتائج التجربة كيف أن منهجية التصميم التوليدي المقترحة باستخدام الذكاء الاصطناعي أنتجت نسخة سطح فريدة.

الكلمات المفتاحية: التصميم التوليدي، شبكات الخصومة التوليدية.

1. Introduction

1.1. GENERATIVE DESIGN

According to Celestino Soddu's simple concept of generative design, it is commonly regarded as a morphogenetic method utilizing algorithms structured as non-linear structures for endless special and unrepeatable effects performed by an idea code as in nature (Soddu, 1994). Several other definitions describe generative design as a method of design focused primarily on particular algorithms or guidelines. Generative design is described by Lazzeroni et al. (2012) as a cyclical process that relies heavily on the feedback loop between the designer and the device. Usually, this method is focused on a basic abstract principle extended to a particular rule. The resulting source code is then returned and re-informed by the designer via a feedback loop.

Architects and programmers have implemented many rule-based generative modelling strategies. This began as early as the explorations by Frei Otto and Frederick Kiesler. In later attempts, methods such as fractals, scaling, superposition, morphing pictures, folding and overlay were used as in the works of Eisenman (2004) and polysurfaces of isomorphism, NURBS, splines, blobs, and animation, as in the works of Lynn (1999). Abdelmohsen et al. (2017) argue that there is a set of complex dynamics that regulate and control the thinking and implementation process of generative methods, which is neither completely rule-based nor intuitive, but rather a combination of both.

1.2. ARTIFICIAL INTELLIGENCE

According to Del Campo et al. (2020), there are special parallels in the way robots perceive visual stimuli and the essence of their world. Machine Learning (ML), more precisely Deep Neural Network Algorithms, depend on expansive image databases and numerous training methods (supervised and unsupervised) to make sense of the contents of a given image. To contextualize this architecturally, architecture students for example learn to

distinguish between various architectural styles. When it comes to distinguishing between for example Gothic, Baroque or Contemporary Architecture, students are instructed to identify these styles by being subjected to hundreds or thousands of photographs of their respective features and building typologies.

The reverse of this procedure – the purpose of creating imagery instead of interpreting it and knowing its content – enables computer vision techniques to be used as a design approach that deeply explores facets of agency and authorship in the presence of Artificial Intelligence in architecture design. This idea is part of a wider debate regarding the essence of human creativity in the area of post-human design ecology. The inherent capacity of Neural Networks to process massive datasets opens up the potential to sift through the vast repositories of imagery created by the discipline of architecture through history in order to find innovative and customized solutions to architectural problems. In addition, AI design methodologies aim to demystify the romantic notion of human creative design decisions in architecture by offering an overview into the inner workings of Neural Network systems and hence the degree of their capacity to guide architectural design.

Leach (2020) emphasized a recent shift in digital techniques with the advancement of sophisticated models of artificial intelligence, including deep learning. The invention of Generative Adversarial Networks (GANs) by Ian Goodfellow specifically opened a new chapter for generative design. According to Chaillou (2020), the study of Goodfellow dramatically transforms the concept of AI from an analysis to a generative agent. Similarly, AI takes architectural issues a step closer in terms of drawing and creation of images. Overall, from basic networks to GANs, AI is now placed to an inexpensive and strong medium through a new wave of resources of ever cheaper open computing resources.

2. GAN's architectural applications

According to the book *Architectural Intelligence*, hundreds of variants of GANs are literally in nature. Besides ArchiGAN, which has been created and defined in the volume by Stanislas Chaillou, CycleGAN has become popular among architects. It involves unpaired datasets and makes it easy to pass the interdomain between set A and set B. Instead of operating at a stylistic level, the network must determine how to pass the concepts of dataset A to concepts of dataset B while seeking the key features. There is normally one GAN generator and one discriminator, but two generators and two discriminators are present for a CycleGAN. Although CycleGAN generators do not produce unique outcomes, performance is not

GENERATIVE DESIGN METHODOLOGY FOR DOUBLE CURVED SURFACES USING AI

compromised, since the outcome is "true". Thus, CycleGANs can consider the peculiar properties of an image dataset and determine if these features can be converted into the other image dataset without pairing examples in preparation.

The goal of Xkool technology is to simplify and enhance design by using deep learning to not only study a variety of alternatives but to produce prototypes on the basis of trained models and then analyze and return the findings from different assessment models. The aim is to improve the design method and to maximize its efficacy. Consequently, StyleGANs and other AI techniques were used to produce images, but not buildings. These buildings in general are more conventional than those produced for example by the media artist Refik Anadol. They represent the contents of the database of used photographs and are mainly contemporary in their aesthetics. These photographs often illustrate and reflect the volume of data since they pull on a wider sample and are thus somewhat simpler and more informative than Anadol's. However, they also do not follow the same quality as StyleGANs, and there are currently still too many errors to reveal that they are not photographs of real buildings (Figure 1).



Figure 1. Xkool-generated hallucinated building images, 2019

Daniel Bolojan has been responsible for utilizing "hallucinating" future Coop Himmelb(l)au buildings using CycleGANs focused on two unmatched picture datasets. Dataset A is focused on a geomorphic structure comparison of pictures, and dataset B is based on current ventures of Coop Himmelblau. The effect is a video of a ride across a fictional Coop Himmelb(l)au landscape. It is important to emphasize that these buildings do not exist. They are all "machine hallucinations" (Figure 2).



Figure 2. “Deep Himmel(l)au” by Daniel Bolojan

Bolojan also conducted the “Gaudi Hallucinations” workshop at the eCAADe-SIGraDi 2019 conference with Emmanouil Vermisso. He also used CycleGANs, but he had one dataset of the interior of Barcelona's Sagrada Familia and another of pictures of walking through the woods (Figure 3).



Figure 3. “Gaudi Hallucinations” by Daniel Bolojan

Bolojan and Vermisso (2019) manipulated the inputs as shown in Figure 4 and Figure 5 to generate the final Fake (A & B) by Domain-Transfer Training for AI in generating new images using CycleGANs based on certain features, including Gaudi's Sagrada Familia's inner space deformation of woods and Gothic datasets.

GENERATIVE DESIGN METHODOLOGY FOR DOUBLE CURVED SURFACES USING AI

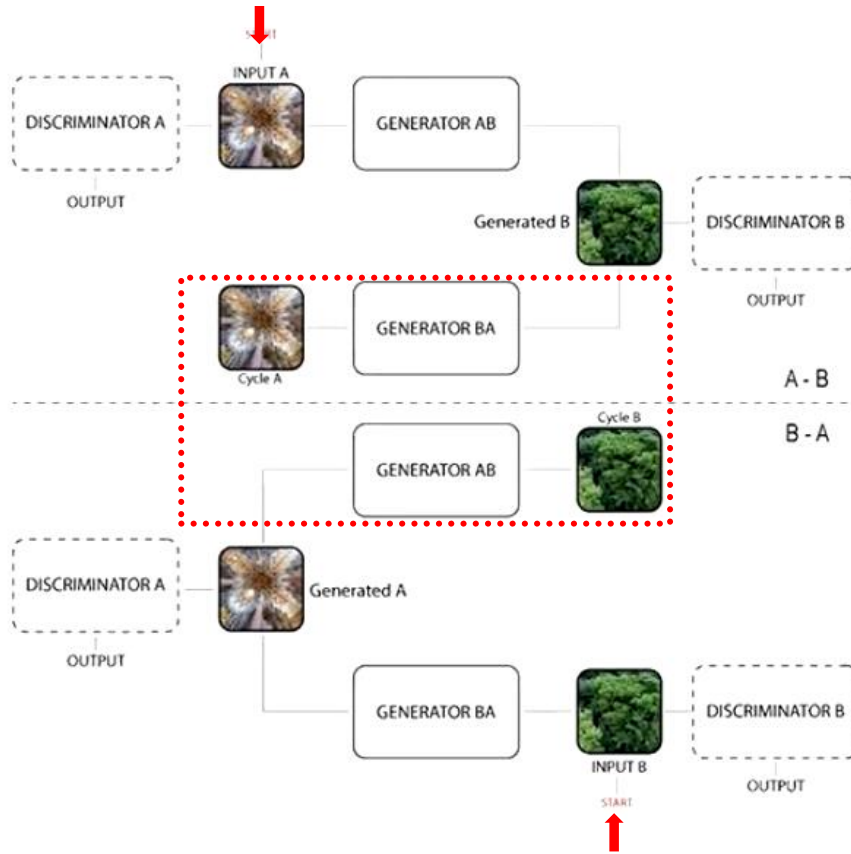

Figure 4. Gaudi Hallucinations workflow (Bolojan and Vermisso, 2019)

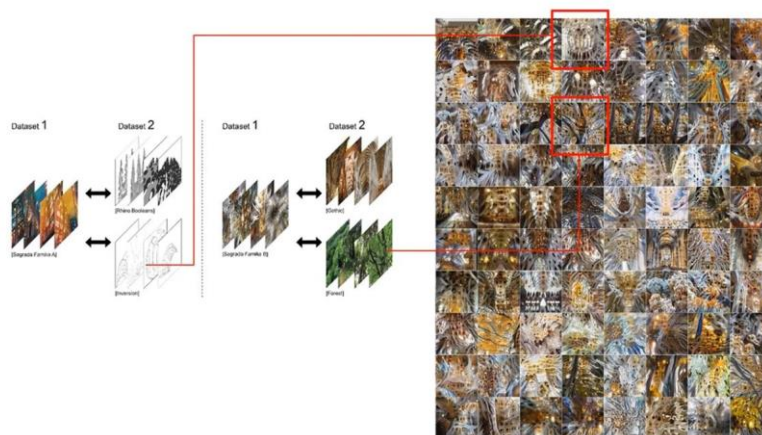

Figure 5. Generation of Fake A & B in Gaudi Hallucinations (Bolojan and Vermisso, 2019)

3. Pilot experimentation

We propose a generative design methodology for producing novel and unique surfaces by faking input surfaces using AI networks. This workflow is applied to two different artificial networks: (1) CycleGAN, (2) Pix2Pix and Augmentor. We introduce below first a pilot experiment with CycleGAN and Pix2Pix, followed by the proposed methodology.

3.1. EARLY PIX2PIX EXPERIMENTATION

In this experiment, we used Rhino3D and Grasshopper (Figure 6) to create a set of images that represents two created surfaces and the Pix2Pix network to learn about mappings between pairs of images (Figure 7).

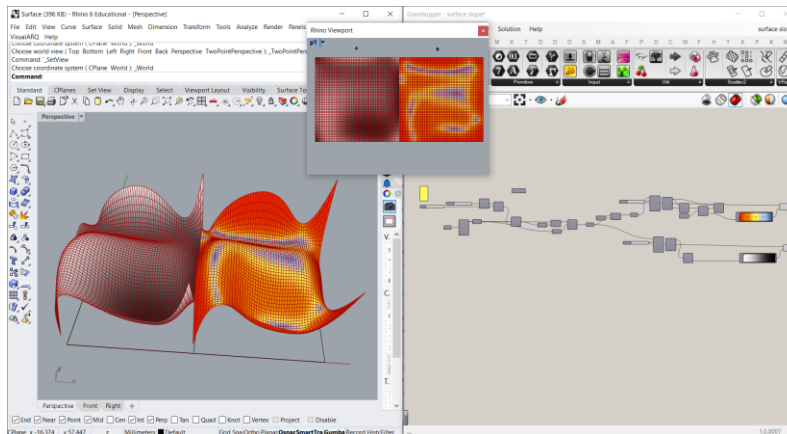

Figure 6. Creating a set of images representing two surfaces using Rhino3D and Grasshopper

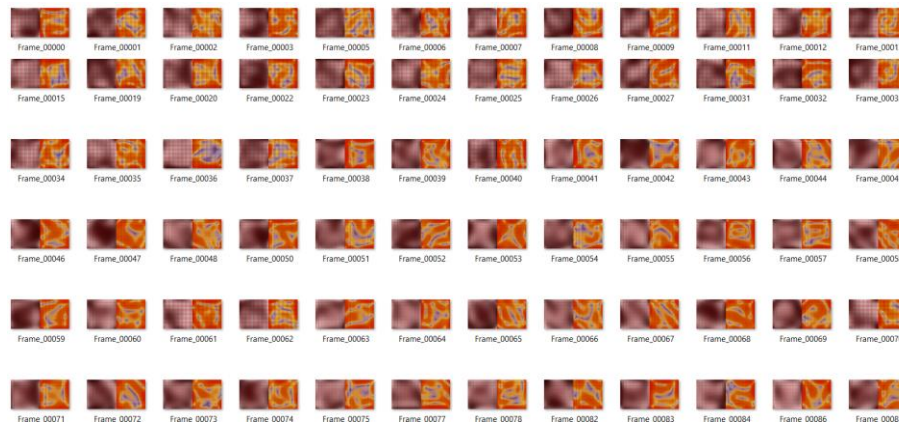

Figure 7. The Pix2Pix output

GENERATIVE DESIGN METHODOLOGY FOR DOUBLE CURVED SURFACES USING AI

3.2. EARLY CYCLEGAN EXPERIMENTATION

In this experiment, we used several patterns downloaded from the Internet (Figure 8) and then used Augmentor (Python script) to generate a dataset based on manipulating the images (Figure 9) as an input to the CycleGANs as training data to learn about the mapping between collections of unpaired images.



Figure 8. The Augmentor input for generating datasets based on image patterns

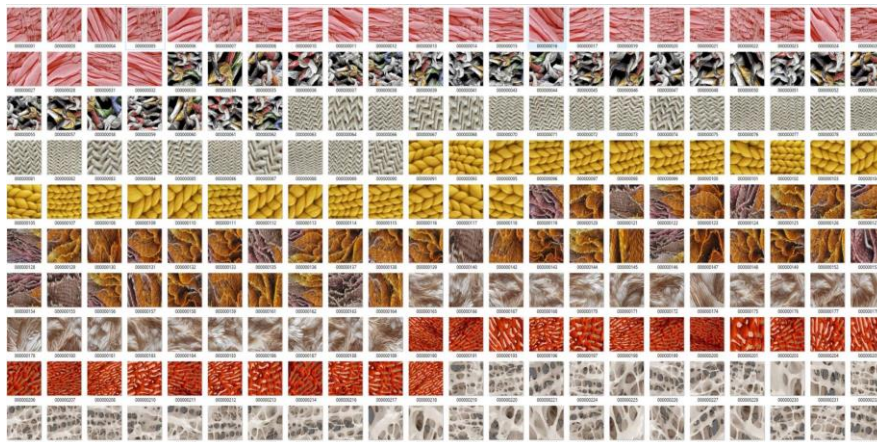

Figure 9. The CycleGAN input

The results of this pilot experimentation however were not fully promising due to the following limitations. The first was related to the small number of input images used as a training material within the network. This has a strong impact on the testing and generation of the experiment outcomes. Also, these few images were not clear enough because Python cropped them from a fewer number. The second limitation was the limited number of out epochs (Figure 10) from the CycleGAN network. Therefore, the less epochs generated, the more inaccurate the outcomes.

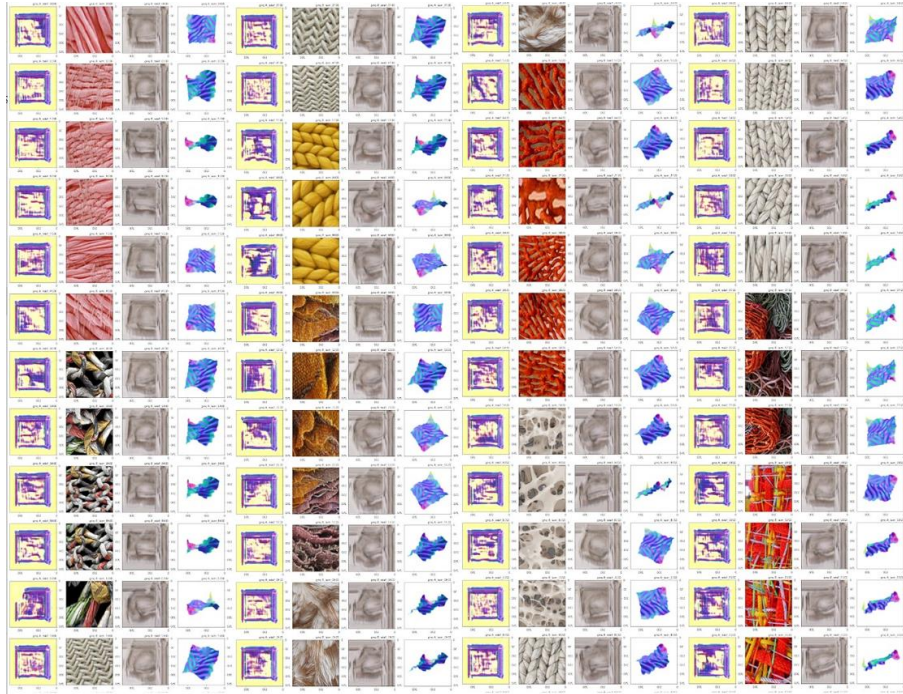

Figure 10. The CycleGAN output

4. The Experimentation

We first used Blender 3D to generate a set of images (Figure 11) to be used as high-quality bump images in the CycleGAN input, based on the positive correlation between the bump input quality and the quality of the results after the high epoch number generated from the GAN network. This direct correlation was concluded from the pilot experiments in Figure 10.

GENERATIVE DESIGN METHODOLOGY FOR DOUBLE CURVED SURFACES USING AI

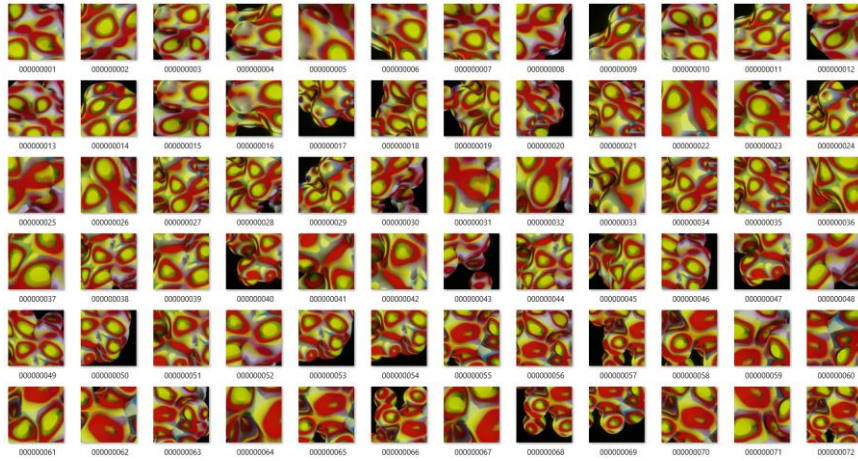

Figure 11. The CycleGAN input

Second, we modeled a surface on Grasshopper (Figure 12) to be manipulated later by the GANs. We created a script to generate colored bitmap images for the surface and the bump image in an equal number (Figure 13). These two sets of images were later manipulated by the GANs.

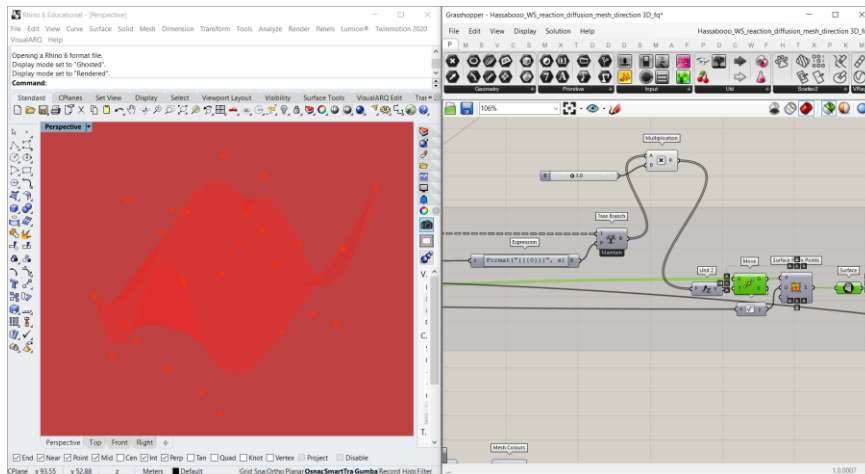

Figure 12. The Grasshopper Generated Surface

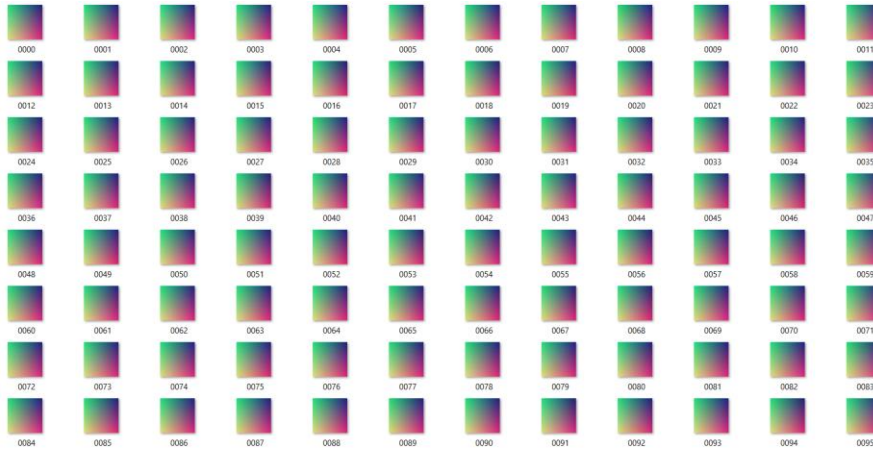

Figure 13. The Colored images exported from Grasshopper

Finally, we used the Colaboratory machine learning and data science environment (<https://colab.research.google.com/>) to manipulate the two input sets (Real A & Real B) of the CycleGANs (Figure 14), generate (Fake A & Fake B) (Figure 15), and re-use Grasshopper to re-generate the 3D surface from the GAN resulting images. Upon running the CycleGANs and Grasshopper script, the experiment results demonstrated how the proposed generative design methodology produced a unique surface version with a higher level of manipulation and result control.

```
[ ] |python train.py --dataset_path ./datasets/Nature2Urban_256 --name Nature2Urban_256_test --load_size 256 --save_latest_freq 256 --gpu_ids 0 --
(epoch: 6, iters: 1, time: 0.609) D_A: 2.652 G_A: 2.514 cycle_A: 9.990 D_B: 2.426 G_B: 1.561 cycle_B: 5.732
(epoch: 6, iters: 2, time: 0.447) D_A: 2.326 G_A: 2.117 cycle_A: 9.643 D_B: 4.719 G_B: 1.200 cycle_B: 4.914
(epoch: 6, iters: 3, time: 0.461) D_A: 1.891 G_A: 1.547 cycle_A: 9.268 D_B: 1.462 G_B: 1.482 cycle_B: 5.600
(epoch: 6, iters: 4, time: 0.449) D_A: 3.464 G_A: 1.331 cycle_A: 8.532 D_B: 1.597 G_B: 1.495 cycle_B: 4.768
(epoch: 6, iters: 5, time: 0.567) D_A: 1.911 G_A: 1.148 cycle_A: 7.270 D_B: 1.680 G_B: 2.033 cycle_B: 4.630
(epoch: 6, iters: 6, time: 0.449) D_A: 1.738 G_A: 1.490 cycle_A: 6.358 D_B: 1.991 G_B: 3.104 cycle_B: 4.338
(epoch: 6, iters: 7, time: 0.447) D_A: 1.257 G_A: 1.259 cycle_A: 5.346 D_B: 1.528 G_B: 2.050 cycle_B: 4.849
(epoch: 6, iters: 8, time: 0.446) D_A: 1.114 G_A: 1.165 cycle_A: 4.663 D_B: 1.703 G_B: 2.241 cycle_B: 3.998
(epoch: 6, iters: 9, time: 0.563) D_A: 0.924 G_A: 0.964 cycle_A: 3.939 D_B: 1.982 G_B: 2.212 cycle_B: 4.731
(epoch: 6, iters: 10, time: 0.456) D_A: 0.890 G_A: 0.812 cycle_A: 3.410 D_B: 1.270 G_B: 1.516 cycle_B: 4.047
(epoch: 6, iters: 11, time: 0.456) D_A: 0.870 G_A: 0.795 cycle_A: 2.882 D_B: 1.093 G_B: 1.196 cycle_B: 4.048
(epoch: 6, iters: 12, time: 0.457) D_A: 0.872 G_A: 0.845 cycle_A: 2.840 D_B: 0.936 G_B: 0.992 cycle_B: 3.805
(epoch: 6, iters: 13, time: 0.552) D_A: 0.749 G_A: 0.778 cycle_A: 3.035 D_B: 0.910 G_B: 1.007 cycle_B: 3.814
(epoch: 6, iters: 14, time: 0.458) D_A: 0.805 G_A: 0.849 cycle_A: 2.631 D_B: 1.023 G_B: 1.026 cycle_B: 3.528
(epoch: 6, iters: 15, time: 0.450) D_A: 1.041 G_A: 1.093 cycle_A: 2.194 D_B: 0.892 G_B: 0.901 cycle_B: 3.528
(epoch: 6, iters: 16, time: 0.452) D_A: 1.534 G_A: 1.860 cycle_A: 1.761 D_B: 0.604 G_B: 0.583 cycle_B: 3.629
(epoch: 6, iters: 17, time: 0.560) D_A: 1.330 G_A: 1.842 cycle_A: 2.016 D_B: 0.662 G_B: 0.755 cycle_B: 4.123
(epoch: 6, iters: 18, time: 0.460) D_A: 1.092 G_A: 1.191 cycle_A: 1.907 D_B: 0.588 G_B: 0.641 cycle_B: 3.426
(epoch: 6, iters: 19, time: 0.455) D_A: 1.018 G_A: 1.234 cycle_A: 1.745 D_B: 0.587 G_B: 0.664 cycle_B: 3.728
(epoch: 6, iters: 20, time: 0.447) D_A: 1.669 G_A: 2.200 cycle_A: 1.559 D_B: 0.520 G_B: 0.535 cycle_B: 3.473
(epoch: 6, iters: 21, time: 0.536) D_A: 1.671 G_A: 2.104 cycle_A: 1.473 D_B: 0.555 G_B: 0.653 cycle_B: 3.571
(epoch: 6, iters: 22, time: 0.452) D_A: 1.273 G_A: 1.598 cycle_A: 1.567 D_B: 0.557 G_B: 0.626 cycle_B: 3.434
(epoch: 6, iters: 23, time: 0.449) D_A: 0.879 G_A: 0.839 cycle_A: 1.620 D_B: 0.563 G_B: 0.627 cycle_B: 3.113
```

Figure 14. The CycleGAN data manipulation in the Colaboratory environment (<https://colab.research.google.com/>)

GENERATIVE DESIGN METHODOLOGY FOR DOUBLE CURVED SURFACES USING AI

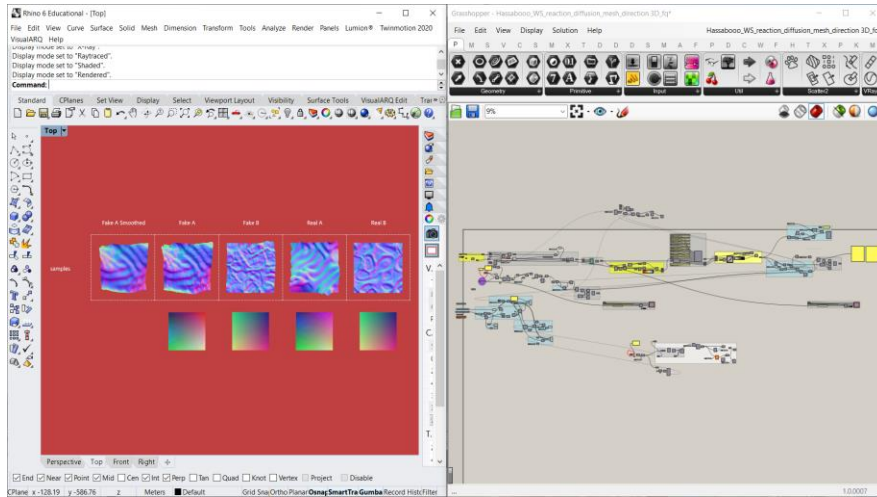

Figure 15. The CycleGAN results

5. Discussion

The research proposes a methodical technique that combines human and technological imagination. We use artificial intelligence (AI) as a platform for interdisciplinary cooperation and interaction. The architect samples and sorts external factors when AI controls their importance and weight in the final surface processing. The strategy we are pursuing involves human-machine cooperation.

Generative design using AI is promising and helpful in developing futuristic designs using machines which are beneficial to tackle new possibilities and alternatives. As mentioned by Daniel Bolojan about his latest development with Wolf D. Prix / Coop Himmelb(l)au, DeepHimmelb(l)au “explores the potential of teaching machines to interpret, perceive, be creative, propose new designs of buildings, augment design workflows and augment architect’s / designer’s creativity.” (Figure 16, 17)

The level of precision using CycleGANS was shown to be based on the number of epochs counted to reach the goal. It can be described as the process of training the GANS Network by providing a dataset, followed by the testing phase. It is therefore conceivable to have as accurate transformations as possible by: (1) maximizing the training dataset with high quality and clear images, and (2) increasing the epochs counted by the GANS. There is thus a direct relation between the training dataset size, the number of epochs, and the quality of the outcomes, and that is the implicit

lesson learned from the early experiments that was applied in the main experiment.

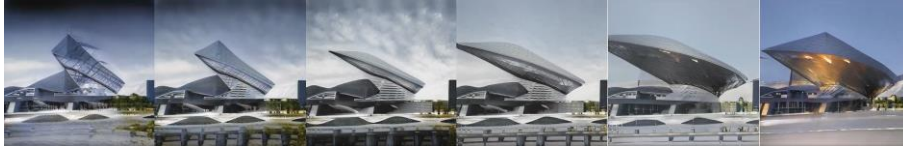

Figure 16. The GANS results, Concept for a convention centre and hotel complex 2021 Wolf D. Prix / Coop Himmelb(l)au by Daniel Bolojan.



Figure 17. The GANS results, Concept for a convention centre and hotel complex 2021 Wolf D. Prix / Coop Himmelb(l)au by Daniel Bolojan.

Acknowledgements

We thank Digitalfutures.world, Tongji University, Neil Leach, Daniel Bolojan (The workshop instructor and the creator of the GANS network), Shermeen Yousif, Manos vermisso, and special thanks for the workshop group members (Sarath Sridhar, and Frank Quek).

GENERATIVE DESIGN METHODOLOGY FOR DOUBLE CURVED SURFACES USING AI

References

- Abdelmohsen, S., Massoud, P., Tarabishy, S. and Hassab, A. (2017). Rule-based vs. intuition-based generative design: an inquiry into the digital chain concept in undergraduate architectural education. *International Journal of Parallel, Emergent and Distributed Systems*, 32(sup1), pp. S199–S209.
- Bantz, C.R., 1995. Social dimensions of software development. *Annual review of software management and development*. Newbury Park, CA: Sage, pp.502-510.
- Campo, M., Manninger, S. and Carlson, A. (2020). Hallucinating Cities -A Posthuman Design Method based on Neural Networks. [online] Available at: <http://simaud.org/2020/preprints/110.pdf> [Accessed 4 Dec. 2020].
- Chaillou, S. (2020). The Advent of Architectural AI. [online] Medium. Available at: <https://towardsdatascience.com/the-advent-of-architectural-ai-706046960140> [Accessed 4 Dec. 2020].
- Eisenman, P. (2004). *Inside out: Selected writings 1963-1988*. New Haven: Yale University Press.
- Hartmut Bohnacker, Benedikt Gross, Laub, J., Claudius Lazzaroni and Frohling, M. (2012). *Generative design: visualize, program, and create with processing*. New York: Princeton Architectural Press.
- Leach, N. (2020). Do robots dream of digital buildings? In: P.F. Yuan, M. Xie, N. Leach, J. Yao and X. Wang, eds. [online] Springer Singapore, pp.59–73. Available at: https://doi.org/10.1007/978-981-15-6568-7_4.
- Lynn G. *Animate form*. New York (NY): Princeton Architectural Press; 1999
- MERCER, P.A. AND SMITH, G., 1993. *Private viewdata in the UK*. 2nd ed. London: Longman.
- Soddu, c (1994). The Design of morphogenesis: An Experimental Research about the Logical Procedures in Design Processes. *Demetra Mag*, pp.1:56–64.
- Yuan, P.F., Yi Min Xie, Jiawei Yao and Yan, C. (2020). *Proceedings of the 2019 DigitalFUTURES: The 1st International Conference on Computational Design and Robotic Fabrication (CDRF 2019)*. Singapore: Springer Singapore.

A GRASSHOPPER PLUG-IN FOR DESIGNING VIRTUAL CAMERA PATH IN RHINO 3D USING CELLPHONE MOTION:

Chameleon

EBRAHIM POUSTINCHI
Kent State University, Kent, Ohio, USA
Email address: mpoustin@kent.edu

Abstract. Chameleon is a workflow plug-in for Grasshopper 3D that enables designers/users to design camera paths and orientation for animation and still rendering, using cellphone position and orientation. Working as a bridge between the physical world and the digital design environment of Rhino 3D, users using Chameleons, can develop animated and still frames from the first-person point of view with realistic walk-through motions/angles. Although this feature is available in animation software platforms, Chameleon aims to unlock this possibility in Rhino 3D environment and the most used design software for three-dimensional modeling. This new workflow also provokes new means and methods for creative interaction with design software, beyond the existing hardware interfaces such as keyboard and mouse.

Keywords: Design, Plugin, Animation, Human-Machin interaction, Interface

ملخص. "Chameleon" عبارة عن مكون إضافي لسير العمل لبرنامج "Grasshopper 3D" يتيح للمصممين / المستخدمين القدرة على تصميم مسارات الكاميرا والاتجاه للرسوم المتحركة وعرض الصور الثابتة، باستخدام موضع الهاتف المحمول والاتجاه. ومن خلال العمل بمثابة جسر بين العالم المادي وبيئة التصميم الرقمي لبرنامج "Rhino 3D"، يستطيع المستخدمون الذين يستخدمون "Chameleon" تطوير إطارات متحركة وثابتة من منظور الشخص الأول مع حركات / زوايا تجول واقعية. على الرغم من توفر هذه الميزة في منصات برامج الرسوم المتحركة، إلا أن "Chameleon" يهدف إلى فتح هذه الإمكانية في بيئة "Rhino 3D" وبرامج التصميم الأكثر استخدامًا للنمذجة ثلاثية الأبعاد. ويؤدي سير العمل الجديد أيضًا إلى استنباط وسائل وأساليب جديدة للتفاعل الإبداعي مع برامج التصميم، بطريقة تتجاوز واجهات الأجهزة الحالية مثل لوحة المفاتيح والماوس.

الكلمات المفتاحية: التصميم، البرمجيات، كاميرا، الرسوم المتحركة .

1. Introduction

In the light of the first and second digital turns in the field of architecture and design, 3D modeling software platforms as new generations of “perspective-machines” produce hundreds of thousands of perspective views in real-time. These views enable the designer to study the potentials of the design and its spatial qualities through a virtual camera and its lens. Frame, viewpoints and “images” are beyond representational elements and are design tool through which designers can design and speculate (Testa, 2017). Although this possibility has tremendously impacted the design and fabrication process, there has been a historical gap between the digital design platform and the physical world of design/experience of the design outcome. In other words, although—because of the digital platforms, the designer—regardless of the scale of design, designs and studies qualities of the project in its full capacity using different digital views and perspective, s/he is not able to design through a more interactive medium where s/he can experience the space from the first-person view perspective and produce or represent them as such.

To address this design and representational gap between the digital and the physical, there has been an adaptation in the field of design regarding the new visualization technologies such as Virtual Reality, Augmented Reality and Extended Reality. This interest of hybridization moves forward in the work of many designers not only as means of representation, but as possible mediums to think through. In his article “Postarchitecture,” Guvenc Ozel calls for a combination of virtual and actual, and argues that our surrounding “space” is a hybrid of both physical materials and electronic bits (Ozel, 2016). Similarly, some other designers used this hybridization as possible mediums for storytelling and experience making within the field of design and architecture (Poustinchi, 2019, 2020, Kruysman, and Proto, 2014).

Although these investigations are extremely valuable in a more advanced design-oriented computational research, most of the mentioned studies are looking at specific software/hardware platforms and in some examples more computationally knowledgeable users. For instance, in “Impossible objects” project by Kruysman and Proto, to create a hybridized digital/physical design/experience environment, a combination of multiple robots, a custom-made python code and advance animation design skills is required.

Similar limitations apply to the existing mixed-reality platforms such as VR, AR, and XR. Although these tools are extremely useful and efficient when it comes to extending the design environment beyond the 3d-modeling software, they all need either an advanced knowledge of another digital platforms—such as game engines, or they need a specific software/hardware interface.

These limitations make the technologies mentioned above not as accessible or as usable, compared to the demand for them. In response, there has been extensive research and development in many of the design/animation platforms to connect 3d modeling software platforms to more common technological interfaces—such as cellphones, as a possible way to bridge the digital and physical when it comes to the design of animation/perspective and experience. One of the successful examples is the VirtuCamera plug-in for Autodesk MAYA. (VirtuCamera – Live Camera Motion Capture App for 3D Artists, n.d.). VirtuCamera plug-in enables designers to control virtual camera in MAYA environment, using their cellphone.

The promises of VirtuCamera is highly desirable and influential as it is entirely independent of any high-tech hardware and does not require any coding. However, there is one limitation about VirtuCamera, and it is the fact that it only works within Autodesk MAYA. It becomes crucial for architects and multiscale designers, who mostly use Rhinoceros 3D as the main 3D-modeling software.

2. Chameleon for Rhino 3D | Methodology

Building upon previous research studies in animation-based software platforms such as Autodesk MAYA and Autodesk 3DMAX, and successful plugins such as VirtuCamera, Chameleons augments camera design possibilities of Rhino and Grasshopper 3D by connecting the camera feed to the physical motions of an assigned smartphone device. Users can see the result in real-time in Rhino3D environment—similar to the walk-through experience, and make modifications and design decisions regarding the camera-path, the design, and the experience it creates.

Using Chameleon, the proposed method seeks an alternative workflow which connects the digital design environment (3D-molding space) and the possible physical interfaces of experiencing/iterating the design, without needing major additional hardware or new software.

Chameleons research is developed around three main themes:

- 1- Advancing the camera design possibilities of Rhino/Grasshopper 3D as design platforms by introducing hand-held camera features.
- 2- Developing a real-time camera design workflow to make the digital animation-making more intuitive.
- 3- Augmenting the digital design process by extending the user interface beyond keyboard, mouse, and other conventional input devices.

A GRASSHOPPER PLUG-IN FOR DESIGNING VIRTUAL CAMERA PATH IN RHINO 3D USING CELLPHONE MOTION: CHAMELEON

2.1. CHAMELEON COMPONENTS

To be able to use Chameleon, there is a need for multiple components to enable the workflow: 1-3D-Modeling Software, 2-Smartphone, 3-Networking and Communication System, and 4-Camera Synchronization Technique. (Figure 1).

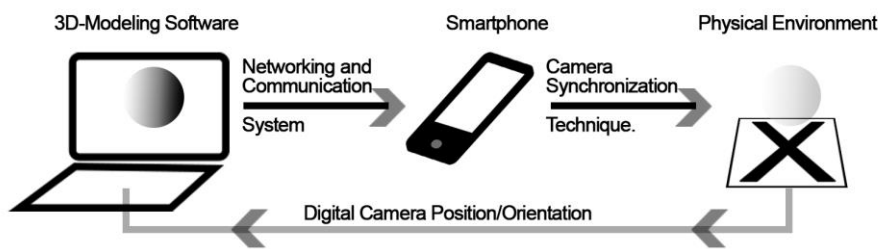

Figure 1. Chameleon workflow and components.

2.1.1. 3D-Modeling Software

To initiate the use of the Chameleon workflow plug-in and start the process, there is a need for a 3D modeled environment. As one of the most used modeling software platforms, Rhino3D has been used as the main 3D-Modeling software.

2.1.2. Smartphone

To be able to bridge the digital world and the physical world, there is a need for a communication device to receive and send data from physical space to the digital and visa versa. Although it is possible to design a custom-made tracking and data communication system, to make the process more accessible, Chameleon uses a smartphone as the bridge.

2.1.3. Networking and Communication System

As part of the promises of Chameleon to enable designers to create digital camera path and walkthrough experiences in realtime using accessible platforms—in this case smartphones, there is a need to send the position/orientation data of the smartphone to the design software—Rhino 3D. There are many different methods of data communication between smart devices and Rhino3D through Grasshopper 3D; communication via UDP, through Python TCP, custom platforms such as touch OSC or wired positions tracking systems, are a few of them.

However, given the promises of Chameleon as an “accessible”/easy to use workflow, and to reduce the number of software installations, we

decided to use some of the embedded features of another popular plug-in in architectural design Fologram—mostly used for fabrication, as a way to connect the smartphone and the Rhino 3D environment (Jahn, Newnham, and Beanland, 2018).

Using Fologram, it is possible to detect the position and orientation of the smart device in Grasshopper 3D as part of Rhino 3D. Although this feature in Fologram is designed to be used as an augmentation for digital fabrication, as part of Chameleon, we use it to connect the smartphone and Rhino 3D.

2.1.4. Camera Synchronization Technique

After establishing the connection, it is time to use this information to synchronize the camera of the cellphone and the digital camera in Rhino 3D environment.

Using custom mesh analysis algorithms in conjunction with the position data from Fologram, Chameleon is able to precisely situate the position of the smartphone camera as a vector. Using this vector and a custom C-Sharp algorithm in Grasshopper 3D, Chameleon can match one of the perspective cameras in Rhino 3D, to move according to the motion/orientation of the smartphone. This synchronization allows for simulating the walkthrough motions and first-person perspectives as means of visualization and design analysis (Figure 2).

3. Testing and Results

To test the Chameleon as a possible easy to use workflow for designing the camera view and path, it was tested as a module in the context of an undergraduate design studio at the Robotically Augmented Design (RAD) Lab at the College of Architecture and Environmental Design at Kent State University. Tested throughout a smaller portion of the semester, students with limited experience with digital animation software platforms used Chameleons plug-in as a way to study and develop first-person experiences using animation as a medium.

Using their projects from the rest of the semester, each student used a combination of digital design environment of Rhino 3D and their personal smartphone devices, to simulate the walkthrough experience as a possible design and visualization strategy.

A GRASSHOPPER PLUG-IN FOR DESIGNING VIRTUAL CAMERA PATH IN RHINO 3D USING CELLPHONE MOTION: CHAMELEON

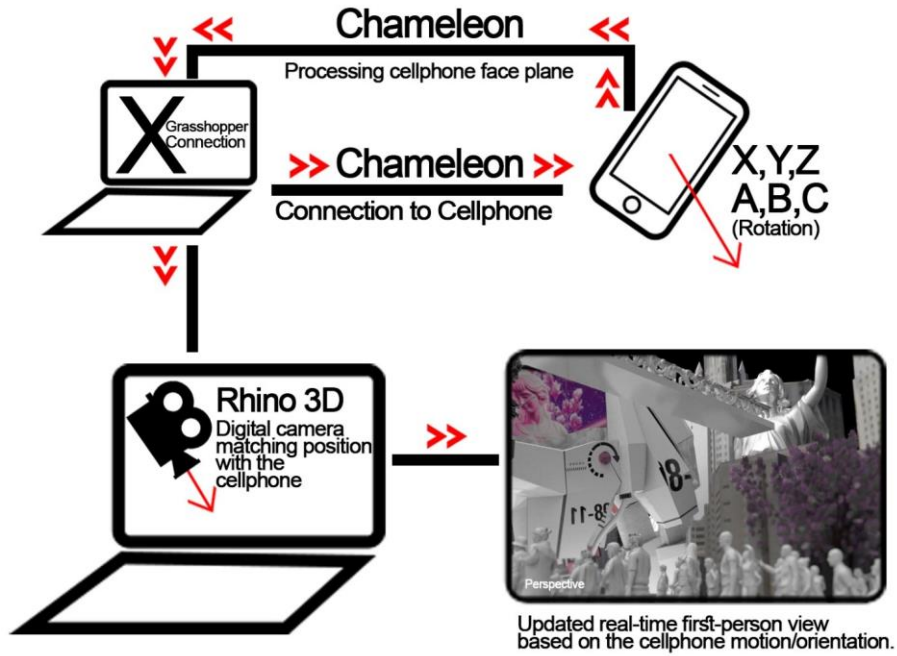

Figure 2. Chameleon process of vector analysis and the use of the smartphone position/orientation as a spatial data set for the digital camera.



Figure 3. Students using a cellphone holder and move their smartphone to curate and design a digital camera path.

This back and forth process between the virtual and actual environments has been tested throughout this research as a pedagogical design medium, to examine the possibilities of a workflow that extends students design environment beyond their computer screens (Figure 3).

The main aim of this article is to propose a new method/workflow for digital camera design through physical interaction using a handheld device, and more analytical studies need more in-depth investigations with a bigger group of users during a more extended period of time. However, during our early observations of students' interaction with the new platform, through informal questioners—a limited number of participants, and as a result of using Chameleon, we observed that students with different digital design backgrounds were able to use this plug-in effectively, not only as an animation design platform but also as a tool to design the user experience. As a parametric yet intuitive platform, Chameleon enabled users to study the digital model and develop multiple walkthrough cameras as a way to develop the design in a hybrid cyberphysical way.

Using first-person studies in the early stages of the design—conception, students were able to examine the spatial effects of their design decisions as part of the ongoing design process. Being able to record the motion-path/camera-path, and replaying the same camera over and over, users were able to use the visual inputs of the experience to modify the space and its qualities (Figure 4).

4. Discussion and Future Research Plans

As both a workflow for parametric camera/animation design and as a potential pedagogical platform, Chameleon investigates the possibilities of a digital camera as a design, experience, and visualization tool. Using a smartphone as an extended tracker for the digital design environment, Chameleons seeks solutions for both immersive and non-immersive design workflows at the same time where designers can walk through the project using the position of the smart device and through the Rhino 3D window while retaining the overall control of the digital design environment.

Different from complete immersive experiences such as VR modeling techniques, Chameleon not only suggests independence from needing more advanced software/hardware platforms—such as Oculus, HTC Vive, Magic leap, etc. but also proposes a possibility to retain the exciting relationship between the design and the design environment—overall control.

A GRASSHOPPER PLUG-IN FOR DESIGNING VIRTUAL CAMERA PATH IN RHINO 3D USING CELLHONEY MOTION: CHAMELEON



Figure 4. Samples of first-person perspective view generation by third-year student YuTing Chang from Studio Ebrahim Poustinchi.

Chameleon research is at its early development stages and is part of a more significant research body on accessible, immersive design platforms. Although the progress leading to the research presented in this article was crucial to the project, there are vital parameters to be tested to situate Chameleon within the possible design/pedagogical toolset. One of the main limitations of the presented work is the limited number of users and the experience duration. As one of the next steps, we are currently looking at testing Chameleon as part of multiple year-level design studios—one-week experience each- and a full semester experience. This would result in a more significant data set for analysis and possible feedback for ease of use as one of the Chameleon's central claims.

E. POUSTINCHI

Another aspect of this project that we are currently developing is the possibility of viewing and editing the design simultaneously and by multiple designers. This additional feature would augment one of Chameleon's main features as a platform that argues for accessibility beyond the need for programming knowledge and additional software platforms.

Acknowledgements

The project presented here are done by students at the Robotically Augmented Design (RAD) Lab at the College of Architecture and Environmental Design at Kent State University.

References

- JAHN, G., NEWNHAM, C. AND BEANLAND, M. 2018, Making in Mixed Reality. Holographic design, fabrication, assembly and analysis of woven steel structures, ACADIA // 2018: Recalibration. On imprecision and infidelity. [Proceedings of the 38th Annual Conference of the Association for Computer Aided Design in Architecture (ACADIA) ISBN 978-0-692-17729-7] Mexico City, Mexico 18-20 October, 2018, pp. 88-97
- KRUYSMAN, B. AND PROTO J. 2014, "Impossible objects," *Architectural Design* 227, edited by B. Sheil. 106–111.
- OZEL, G. 2016 "Toward a postarchitecture," *Log* 36, 99-105
- POUSTINCHI, E. 2019, "Robotically Augmented Imaging (RAI Alpha)" In ACADIA 19: UBIQUITY AND AUTONOMY [Proceedings of the 39th Annual Conference of the Association for Computer Aided Design in Architecture (ACADIA) ISBN 978-0-578-59179-7] (The University of Texas at Austin School of Architecture, Austin, Texas 21-26 October, 2019) pp. 352-359
- POUSTINCHI, E. (2020). Robotics as a Storytelling/Experience Medium (Raasem). In: Data, Matter, Design: Strategies in Computational Design, eds. Melendez, F., Diniz, N., & Signore, D. M. (2020). (1st ed.). Routledge.
- TESTA, P. 2017. "Imaging," in *Robot House*, edited by P. Testa, New York, NY: Thames & Hudson Inc., 155-219.
- VIRTUCAMERA – LIVE CAMERA MOTION CAPTURE APP FOR 3D ARTISTS. (n.d.). VirtuCamera. Retrieved December 9, 2020, from <https://virtucamera.com/>

D2.P1.S3

ARCHITECTONIC LANGUAGES IV

APPLYING URBAN PARAMETRICISM IN THE DESIGN OF DYNAMIC NEIGHBORHOODS

MARWA KAMAL FAHMY

Architecture Department, Helwan university, Egypt

Email address: Marwa_fakhry@m-eng.helwan.edu.eg

Abstract. Neighborhoods are considered basic spatial units of an urban area. Their forms have complex and hierarchical structures that contain building layouts, street segments, street networks and etc.. The traditional ways of computationally producing neighborhoods have proven incompetence. Some of these conventional ways focus on the morphological approaches, but they do not include all urban features. Meanwhile, other models that can design urban features have limited formulation flexibility. Besides the absence of dynamic generation behavior as they don't use parametric techniques. They lack interactivity with the surroundings as they don't use streets as the main generator of neighborhoods. Additionally, they don't have the ability of automatically analyzing the site. Other models are generated for a specific location and miss the interactivity with other sites. This study implements parametric techniques to generate an urban model with wide design varieties. Furthermore, the model has dynamic morphological behavior, capable of interacting with the designer's modifications. This study focuses on the streets and grid as the dominant element of neighborhoods. The study also presents a predefined function in the scripting process. The model also proposes a python switcher to allow easy accessing all the inputs. Also, the research converts the elements to be more interactive, responsive, flexible, and dynamic. Therefore, all the neighborhood elements are simultaneously created according to user requirements. The study method is divided into three stages: Decomposition, Formulation, Modeling, and evaluation. Each process is defined with its tools, inputs, and parameters.

Keywords: *Urban Parametricism, Algorithmic design, Predefined function, Dynamic neighborhoods*

APPLYING URBAN PARAMETRICISM IN THE DESIGN OF DYNAMIC NEIGHBORHOODS

الملخص. تعتبر المجاورة السكنية الوحدة الأساسية للمناطق الحضرية. تحتوي أشكالها على هياكل معقدة ومتدرجة مكونة من تخطيطات المباني وشبكات الشوارع. وقد أثبتت الطرق الحسابية التقليدية لتصميم المجاورات عدم الكفاءة. حيث يركز البعض منها على الأساليب التشكيلية، ولكن لا يشمل جميع عناصر المجاورات. وفي الوقت نفسه، تتمتع النماذج الأخرى التي يمكنها تصميم مجاورات متكاملة التفاصيل بمرونة محدودة في الصياغة التشكيلية. إلى جانب عدم وجود سلوك ديناميكي مرن في التصميم و ذلك لانهم لا يستخدمون الأساليب البارامترية. ويفتقرون إلى التفاعل مع المناطق المحيطة لأنهم لا يستخدمون الشوارع كعنصر رئيسي بالإضافة إلى ذلك، ليس لديهم القدرة على التحليل التلقائي للموقع. وقد يتم تصميم نموذج أو خوارزمية لموقع معين ويفقد التفاعل مع المواقع الأخرى. تطبق هذه الدراسة تقنيات بارامترية لتوليد نموذج حضري. علاوة على ذلك، يتميز النموذج بسلوك تشكيلي ديناميكي مرن قادر على التفاعل مع تعديلات المصمم. تركز هذه الدراسة على الشوارع والشبكات كعنصر مهيمن في تصميم الأحياء. وتقدم الدراسة أيضا دوال برمجية لكل عنصر من عناصر المجاورة. ويقترح النموذج أيضا أداة لسهولة التبديل جميع المدخلات تم كتابته بلغة البيثون.. تنقسم طريقة الدراسة إلى ثلاث مراحل: التحليل، والصياغة، والنمذجة، والتقييم. يتم تعريف كل عملية بأدواتها ومدخلاتها ومعلوماتها.

الكلمات المفتاحية: البارامترية الحضرية، التصميم بالخوارزميات، الدوال البرمجية، المجاورات السكنية المرنة

1. Introduction

Neighborhoods forms have complex and hierarchical structures that contain building layouts, street segments, neighborhood layouts, and street networks. (Aschwanden, 2016); (Sileryte et al., 2017); (Moosavi, 2017). When Patrik Schumacher created the term `parametricism` to represent a new design theory, Parametricism was not utilized yet to solve the problems of modern cities. But today, parametricism proves itself to be used as an operational tool for all scales of urban design applications. (Caliskan, 2017; Schumacher, 2009; Steinø and Obeling, 2014). In 2002, Zaha Hadid implemented the urban parametricism strategies in the “One North” masterplan in Singapore. Later in 2005, the idea has been mentioned in lectures by Schumacher in DRL (Design Research Laboratory) (Canuto and Amorim, 2012). Afterward, Frei Otto published his pioneering research on natural structures for settlement patterns in 2009 relational fields.(Otto, 2009; Schumacher, 2009; Verebes, 2014). Since then, many researchers and urban design schools have been interested in urban parametricism in their publications and workshops. such as (Behnam and Zarabadi, 2017; Boeing, 2018; Caliskan, 2017; Calvano et al., 2018; Chowdhury and Schnabel, 2018a, 2018b; de Castro et al., 2018, 2018; Newman, 2018; von Richthofen et al., 2018).

These Previous models have various incompetence: Some models focus on the morphological approaches, but they have limited ability to address all urban features. Hence, the models cannot be applied in a real context DRL-Otto’s researches. Meanwhile, other models produce urban features with

limited morphological flexibility. They can only produce rectilinear street patterns through given gateways without the ability to insert maps. (Koenig et al., 2017). Additionally, they don't allow users to generate streets. Therefore, they miss the interactivity with the surroundings, and the user cannot control the urban pattern. Hence, they lack the dynamic generation behavior. Other models are generated for a specific location, and they can't be applied to different sites (Zaha Hadid projects). So, developing flexible, responsive, interactive, and dynamic models is necessary. Using parametric tools with the help of programming techniques enables urban designers to create, manage, and organize complex and vibrant models by integrating diverse parameters. (Batty, 2013; Vidmar and Kozelj, 2015). Aspects such as streets, lots, spaces, and densities can be translated into parameters or variables with easy access. (Boyer, 2015).

This study proposes an urban design model by experimenting parametric tools to generate and control the urban model. This model is scripted in Grasshopper with the help of Ghpython. The model gives wide varieties for urban designers to generate neighborhoods and allow real-time visualization. It also enables the analysis of the alternative design scenarios. It has dynamic design behavior, capable of responding with the designer's modifications since the associativity between the parameters. The model receives maps downloaded from open street map site www.openstreetmap.org and generates a conceptual masterplan. The model can automatically analyze the map and extract gateways from the location. The study concentrates on the streets and grid as the dominant element of neighborhoods. By using streets as the main element, the model can interact better with the surroundings and produce wide morphological design possibilities. Moreover, the urban pattern can be perfectly controlled. The study also presents a predefined function for each element, which are used in the model script. The model also proposes a switcher -scripted with ghpython- that easily accesses all the inputs. Finally, the model considers the neighborhood center as an element without details. It does not concentrate on the land use of the building. It includes the open spaces in the neighborhood center area and the private courtyard of the building.

2. Research Method

This study method is divided into four stages. The first one is decomposition: it includes identification of parameters; Parameters identify the neighborhood

APPLYING URBAN PARAMETRICISM IN THE DESIGN OF DYNAMIC NEIGHBORHOODS

are chosen. Then, the chosen parameters are classified and grouped according to their correlations. The second one is formulation which determines the technique which is used to build the model. The third stage is modelling: illustrates the phases of the model generation. And the processes included in each phase. Each process is defined with its tools, inputs, and parameters. Then, the implementation of the model. And finally, is evaluation which is divided into two stages; the first one is computing the connectivity of the generated neighborhoods. This stage helps urban designers automatically evaluate the model results. The second one is the model validation; it applies the model in real context to validate it.

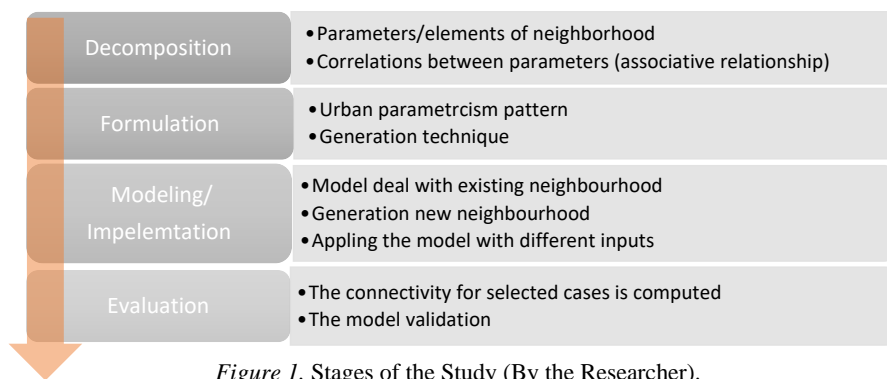

Figure 1. Stages of the Study (By the Researcher).

2.1 SOFTWARE

The following software and plugins have been used in the generation process:

1) OSM, 2) Potlatch2 (OSM plugin), 3) Rhino 3D, 4) Grasshopper (Rhino plugin), 5) Elk (grasshopper plugin), 6) GhPython (grasshopper plugin), 7) Attractor (grasshopper plugin), 8) Tree (grasshopper plugin), 9) Decoding space (grasshopper plugin), 10) Urban network analysis (Rhino plugin).

2.2 DECOMPOSITION

In this process neighborhood parameters are chosen, specified, and grouped. Then, a correlation between the parameters is made.

2.2.1 Neighborhood Parameters

In this part, all the parameters of the neighborhood and correlations between them are studied and analyzed. The Flowchart in figure 2 shows the correlation between parameters and the algorithmic order. The parameters of the neighborhood are defined as the following:

- **Gateways:** Gateways have two types; the first one is the gateways from the existing location. The second type is the gateways extracted from the generated neighborhood. It is used to create the connectors by connecting both gateways.
- **Streets:** Streets include Streets pattern, Arterial, Connector, and Access streets. Arterials and connectors have the same function as the scale of this study is the neighborhood scale. The connectors have two parameters: either connect the gateways or connect the generated centers “*service streets*”.
- **Neighborhood Centers:** The neighborhood center location can move along the connectors with changeable catchments.
- **Clusters:** The neighborhood includes three types of clustering (freestanding building, row building, and block building). So, the scripting parameters of the clusters contain types of clustering, building height, floor number, and private open spaces ratio for each building type.
- **Open Spaces:** Open spaces are three types 1- area ratio included in the center catchment, 2- ration from the parcels at least 10%, 3- the courtyards included in the clusters.

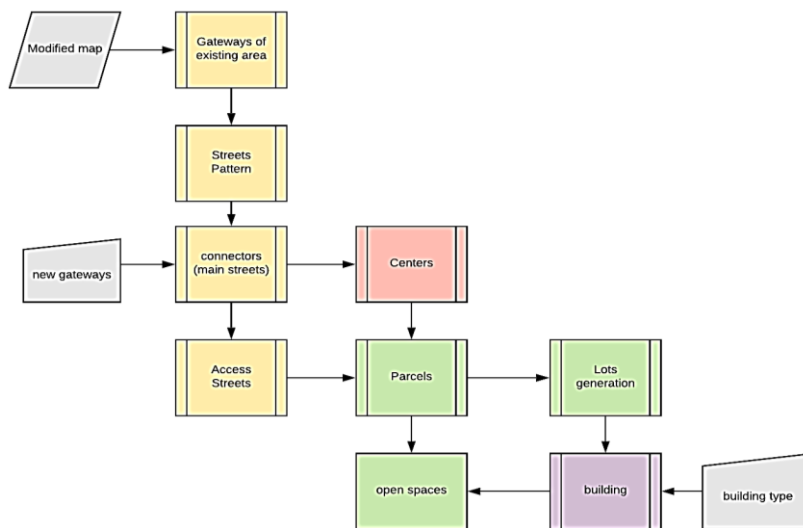

2. Flowchart shows the correlation between parameter and the algorithmic order of them (By the researcher).

2.3 GENERATION TECHNIQUE (FORMULATION)

The study combines Reactor and Tiling as urban parametricism patterns or techniques. First, a spatial grid is generated. The grid acts as

APPLYING URBAN PARAMETRICISM IN THE DESIGN OF DYNAMIC NEIGHBORHOODS

the generator of the street pattern. The “*access streets*” depend on the grid pattern. The street width should be dynamically determined. The “*connectors*” are determined firstly, then *access streets*. It can be designed according to two strategies; The connectors can follow the grid pattern or cuts the grid. Thus, the designer should insert it as polyline. The connectors depend on the gateways. Then, the centers are generated according to the gateway’s articulation. Next, the parcels are determined, which includes the lot-contains. Building types affect open space. The open space parameters are influenced by the catchment of the center and the parcel generation. The following flowchart describes the correlation between parameters and the algorithmic order.

2.4 MODELLING

The modeling process contains two main phases. Each phase has inputs, parameters, software, and outputs. Each element is scripted as predefined functions. Meanwhile, a switcher includes all choices possibilities is programmed. The Predefined scripts are 1) Streets generator from a given pattern, 2) Connector type 1, 3) Connector type 2 (one / two connectors), 4) Neighborhood Center, 5) Attractor effect, 6) Parcel/building types, and 7) Division of Building Types into three Sectors.

2.4.1 Modelling Phases

the modelling is divided into two phases; Phase one which consists of Inserting the map data into Grasshopper, analyzing the map data to determine the main streets (connectors/arterials), and automatically determine the gateways. Any map can be downloaded from www.openstreetmap.org. And phase two which contains all algorithms that generate the neighborhood. It consists of three scripts: The First script generates the street pattern, the second script determines the main streets, service streets, and the neighborhood center as three different scripts, Finally the third one generates parcels, lots area, and the building types with courtyards.

2.4.2 Model Capabilities and Limitations

The model creates neighborhoods based on streets and spatial grids-based pattern (hexagonal, rectangular, and triangular). The model script a switcher to easily switch between the inputs option. With the switcher, the user can navigate easily between cases without connecting wires to components in the scripting part. The switcher script is divided into four parts. It offers three base pattern varieties. It has nine groups of inputs: 1. base pattern of the

neighborhood (hexagonal, rectangular, or triangular), 2. Choosing the connector type 1,2, 3. The number of connectors, 4. The sectors number, 5. Attraction effect, 6. number of tiles in the x-direction, 7. Several tiles in the y-direction, 8. The size of the tiles, 9. Finally, the points that affect the location of the sector.

2.5 EVALUATION

This model is evaluated through connectivity and model validation. The connectivity can be measured through *Accessibility* and *Centrality* to allow the urban designers to analyze their generated neighborhoods. Therefore, it helps them in decision making. It is demonstrated in figure 3.

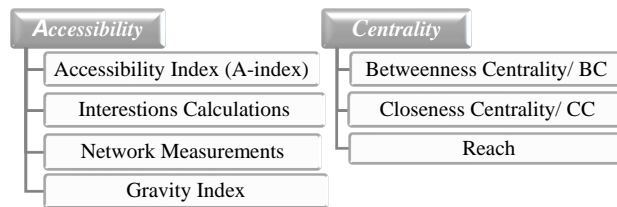

Figure 2 Connectivity computing (By the author).

3. Results

3.1 APPLYING THE MODEL AND SAMPLE SELECTION

The samples are selected to include three case studies for each grid pattern: The first one is a grid without *Attraction* with the connector follows grid patterns, the second one is a grid with the *Attraction*, and between two streets with connectors cutting the pattern. Finally, the third one is the extended neighborhood. Table 1 demonstrates the model implementation.

TABLE 1 Applying the model (By the researcher)

Parameters		Streets	Connectors / service street	Clusters	Neighborhood	
Rectangular grid	Case1	two connectors follow the pattern. 190 size/ 6*7 Without attractor				
	Case2	Two connectors Cut the pattern. 165 size/ 8*8 With attractor				

APPLYING URBAN PARAMETRICISM IN THE DESIGN OF DYNAMIC NEIGHBORHOODS

Triangular grid	Case3	Two connectors cut the pattern. 145 size/ 18*8 With attractor Three sectors				
	Case4	One connector Cut the pattern. 200 size/ 10*11 With attractor one sector				
	Case5	Two connectors Cut the pattern. 235 size/ 17*12 With attractor Three sectors				
	Case6	one connector cut the pattern. 235 size/ 11*15 With attractor Three sectors				

TABLE 2 Continued.

Hexagonal grid	Case7	One connector Cut the pattern. 101 size/ 10*7 Without attractor Three sectors				
	Case8	Two connectors Cut the pattern. 119 size/ 9*8 With attractor one sector				
	Case9	Two connectors Cut the pattern. 145 size/ 13*7 With attractor Three sectors				

3.2 CONNECTIVITY CALCULATION

This evaluation is applied to the generated neighborhood. Some sample are chosen to apply the computing process. it is useful to evaluate neighborhoods. The results are not fixed they depends on the neighborhood features. The process helps in taking the decision in the early designing stage.

TABLE 2. Applying the Accessibility (By the researcher)

	Case 1	Case 2	Case 9	Case 8
neighborhood				
A- inde	BuildAdjacencyDev : 93.7233 [ms]	BuildAdjacencyDev : 46.8582 [ms]	BuildAdjacencyDev: 62.4932 [ms]	BuildAdjacencyDev: 46.8663 [ms]



Intersections	70 629.115938		Num. of intersection=120 Average distance=720 m	Num. of intersection=169 Average distance=1171.765 m
Network measurements	Network length=31919.99999 Network density = 0.021053	Network length=48701.741774 Network density = 0.028446	Network length=41999.99962 Network density = 0.023094m/m square	Network length=67275.382884 Network density = 0.021739
Gravity index				

TABLE 3. Applying the Centrality (By the researcher)

	Case 1	Case 2	Case 9	Case 8
BC				
CC				
Reach				

3.3 VALIDATION

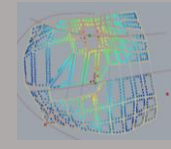
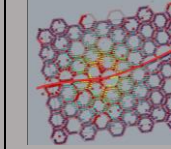
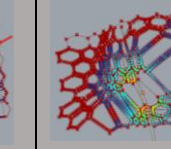
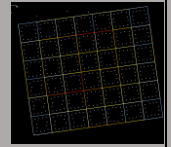
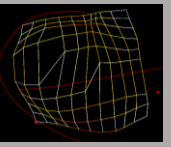
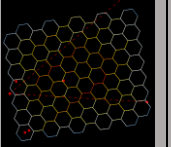
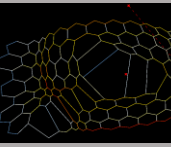
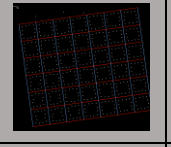
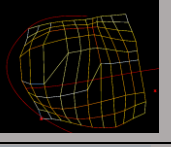
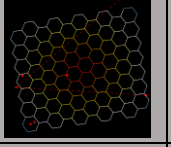
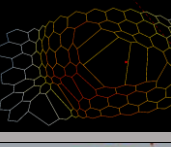
3.3.1 Criteria of Validation

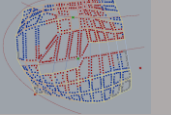
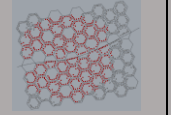
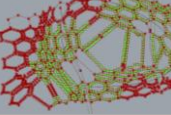
The model is validated through applying it in real context. The process starts with Inserting the fixed parameters as an input to the algorithmic model. Then, generating different variation from the model with different parameters .

3.3.2 Nominative Site

The study chooses a location in the El Banafseg district, first settlement, new Cairo, Egypt. The area is surrounded with (Youssef Elsebai) streets from the north and (Ahmed Okasha) from the south, (Mohammed Najib Axes) from the east, and (Ahmed Shawqi) from the west. Figure 4 demonstrates the location.

APPLYING URBAN PARAMETRICISM IN THE DESIGN OF DYNAMIC NEIGHBORHOODS

3.3.3 Criteria of Nominative Site

The validation can be applied to any location. The site should be located in Egypt, between the neighborhood scale and district scale, surrounded by streets from all directions, and located in slums.

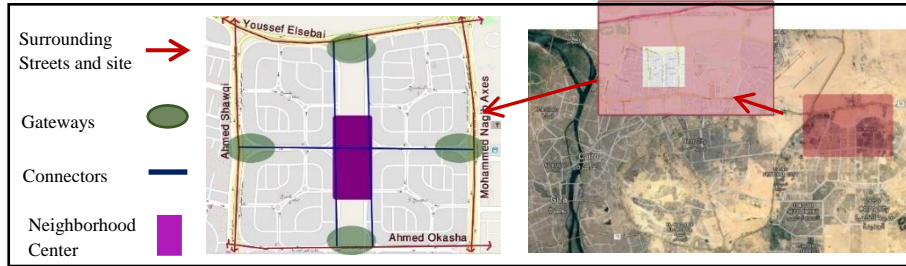

Figure 4. Location of the validation process (By the researcher).

3.3.4 Applying the Model with Fixing some Parameters

The following table includes the results of four different cases. Each case fixes one parameter. The model is applied with three different parameters: hexagonal, rectangular, triangle.

TABLE 4 Validating the model by applying it on the selected location (By the author)

Model Parameters	Existing Neighborhood				
	Base grid	Fixes parameters			
		Case 1 Edges Only	Case 2 Connector/edge	Case 3 Gateways/edge	Case 4 NC/edge
Hexagonal One/Two connectors Connector width=20 Street width=11 Location of center =0.5 Radius of center 176 Tree sectors Num. of pattern 12*9 With Attraction					
Rectangular One/Two connectors Connector width=20 Street width=11 Location of center =0.5 Radius of center 155 Tree sectors Num. of pattern 9*9 Size of unit = 162 With Attraction					

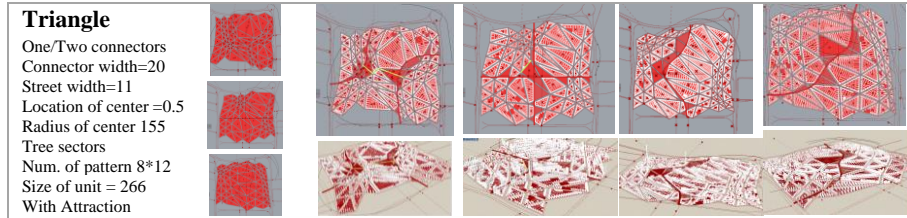

4. Discussion and Conclusion

4.1 NEIGHBORHOOD'S CHOSEN PARAMETERS

The neighborhood is analyzed to extract the parameters used in the modeling process. The dynamic neighborhood develops the livable neighborhood model by making the center dynamic -by the ability to move along the connectors-. The street pattern is affected by the base grid. It can be considered the main generators of the neighborhood. Thus, by changing the street pattern, all the elements are accordingly modified. The street pattern affects the spatial pattern which forms the parcels. The parcels are divided consequently to generate different building types with their required open spaces.

4.2 GENERATING DYNAMIC NEIGHBORHOOD

Urban parametricism depends on algorithmic thinking, which enable urban designers to manipulate or alter the result. Before Writing the algorithms, the correlation between the neighborhood elements should be defined. The algorithm automatically generates neighborhoods. After writing algorithms, urban designers can use these parameters in the form of sliders or geometric components to control the neighborhood form. This technique explores the wide range of possible solutions. This study applies urban parametricism by writing algorithms combine parametric techniques -affecting the tiling patterns with the attractor. It also uses the programming techniques to scripts predefined function which helps writing the main scripts. The tiling pattern dynamically changes depending on the geometry given to the attractors. And the changes in the graph mapper. The model started with the streets or grid to generate the urban model. Thus, all the neighborhood elements are automatically created according to the user requirements. Figure 4 demonstrates the process. The study develops an algorithm to interact with the surrounding sites (by extracting streets and gateways). Figure1 shows some solutions that the model offers through the changing of the street pattern.

APPLYING URBAN PARAMETRICISM IN THE DESIGN OF DYNAMIC NEIGHBORHOODS

4.3 EVALUATION PROCESS

This process is divided into two stages the first one is computing the connectivity. This measurement is not permanent. Therefore, it changes by changing the parameters. Four cases are computed in table (2). This algorithm helps the urban designers in the design stage to decide which pattern fits the planning requirements. The second stage is validation. the model is validated by taking one parameter from the site as fixed parameters and apply the model processes. The fixed parameters are (location edges, connectors, gateways, and neighborhood center). It can be noticed the using parametric design produces more dynamic neighborhoods. It gives the ability to fix some parameters from the site and include it in the generation process. as illustrates in table (3). In the first case, the edge of the selected site is kept. That gives wide possibilities to choose all the other parameters to generate a limitless number of neighborhood forms contains all feature. Secondly, the study fixes the connectors and the edge. This case can happen if the future development of a site requires the main streets to remain. The model interactives well with the insert of the connector. Then, gateways and neighborhood center are fixed.

5. Future Development of the Model:

- a) Convert the model into a Grasshopper plugin to ease the using and downloading it and add more parametric techniques and patterns.
- b) Develop the mold to work on user sketch or polylines drawn by the user to increase the model flexibility and interactivity with the user requirements and to increase the generation opportunities.
- c) Script more predefined function such as Streets features, land use computing according to the determined neighborhood area and the optimal location for each one, Including the social and cultural aspects of the place to be added as parameters or inputs.
- d) Increase]se the smartness of the model by adding machine learning algorithms in the map analysis and clustering.

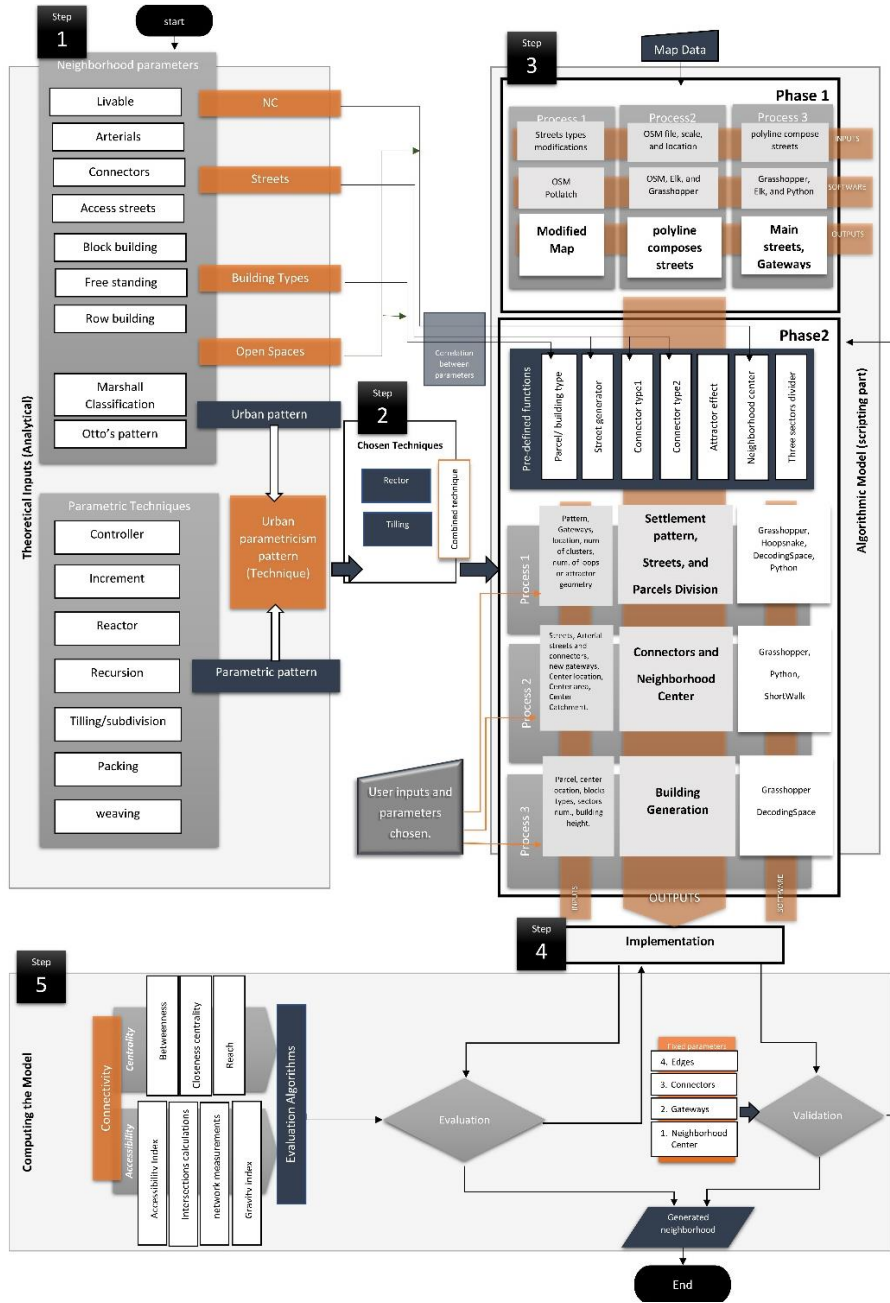

Figure 5 The Framework of Generating the Dynamic Neighborhood (By the Researcher)

APPLYING URBAN PARAMETRICISM IN THE DESIGN OF DYNAMIC NEIGHBORHOODS

6. References

- Aschwarden, G., D.P.A., 2016. Neighbourhood detection with analytical tools, Identifying neighbourhoods from geospatial and transportation data through graph evaluation and learning algorithms. 21st International Conference of the Association for Computer-Aided Architectural Design Research in Asia CAADRIA, 13–22 10.
- Batty, M., 2013. *The new science of cities*. Cambridge, Massachusetts: The MIT Press.
- Behnam, S.J., Zarabadi, Z.S., 2017. Parametric Design as an Approach to Respond to Complexity. *World Academy of Science, Engineering and Technology, International Journal of Civil, Environmental, Structural, Construction and Architectural Engineering* 11, 875–880.
- Boeing, G., 2018. Measuring the Complexity of Urban Form and Design. *Urban Design International*. <https://doi.org/10.1057/s41289-018-0072-1>
- Boyer, M.C., 2015. On modelling complexity and urban form. *Architectural Design* 85, 54–59. <https://doi.org/10.1002/ad.1977>
- Caliskan, O., 2017. Parametric Design in Urbanism: A Critical Reflection. *Planning Practice & Research* 32:4. <https://doi.org/10.1080/02697459.2017.1378862>
- Calvano, M., Casale, A., Ippoliti, E., Guadagnoli, F., 2018. RESPONSIVE URBAN MODELS BY PROCESSING SETS OF HETEROGENEOUS DATA. *ISPRS - International Archives of the Photogrammetry, Remote Sensing and Spatial Information Sciences XLII-2*, 193–200. <https://doi.org/10.5194/isprs-archives-XLII-2-193-2018>
- Canuto, R., Amorim, L., 2012. Establishing parameters for urbanity. Presented at the Eighth international space syntax symposium, Santiago de Chile: PUC, pp. 1–17.
- Chowdhury, S., Schnabel, M.A., 2018a. A Communication System in Urban Design Process: An Algorithmic Neighbourhood Design Approach, in: *Design Communication Association, 3D*. Presented at the A Communication System in Urban Design Process, New York, USA, pp. 271–279.
- Chowdhury, S., Schnabel, M.A., 2018b. An Algorithmic Methodology to Predict Urban Form - An Instrument for Urban Design, in: *Proceedings of the 23rd International Conference of the Association for Computer-Aided Architectural Design Research in Asia (CAADRIA)*. Presented at the Learning, Adapting and Prototyping, CUMINCAD, Hong Kong., pp. 401–410.
- de Castro, M.M., Moura, A.C.M., Nogueira, R.H., de Aguiar, T., de Oliveira, F.H., 2018. Parametric Modeling as an Alternative Tool for Planning and Management of the Urban Landscape in Brazil – Case Study of Balneario Camboriu. *DISEGNARECON* 11, 17.1–13.
- Koenig, R., Miao, Y., Knecht, K., Buš, P., Mei-Chih, C., 2017. Interactive Urban Synthesis Computational Methods for fast Prototyping of Urban Design Proposals, in: *Computer-Aided Architectural Design. Future Trajectories*. Presented at the 17th International Conference, CAAD Futures 2017, Springer Nature Singapore Pte Ltd., Istanbul, Turkey, pp. 23–41. https://doi.org/10.1007/978-981-10-5197-5_2
- Moosavi, V., 2017. Urban morphology meets deep learning: Exploring urban forms in one million cities, town and villages across the planet. *arXiv preprint arXiv:1709.02939*.
- Newman, M., 2018. *Networks, Second Edition*, New to this Edition: ed. Oxford University Press, Oxford, New York.
- Otto, F., 2009. *Occupying and Connecting: Thoughts on Territories and Spheres of Influence with Particular Reference to Human Settlement*. Edition Axel Menges, Stuttgart.
- Schumacher, P., 2009. Parametricism: A New Global Style for Architecture and Urban Design. *Archit Design* 79, 14–23. <https://doi.org/10.1002/ad.912>

M. FAHMY

- Sileryte, R., Cavic, L., Beirao, J.N., 2017. Automated generation of versatile data model for analyzing urban architectural void. *Computers, Environment and Urban Systems* 66, 130–144. <https://doi.org/10.1016/j.compenvurbsys.2017.08.008>
- Steinø, N., Obeling, E., 2014. Developing a parametric urban design tool. Some structural challenges and possible ways to overcome them. *Architecturae et Artibus* 6, 51–57.
- Verebes, T. (Ed.), 2014. *Masterplanning the adaptive city: computational urbanism in the twenty-first century*. Routledge/Taylor & Francis Group, London ; New York.
- Vidmar, J., Kozelj, janez, 2015. *Adaptive urbanism: aparametric map approach*. University of Ljubljana, Faculty of Architecture, Faculty of civil and Geodetic Engineering, the creativity game theory and practice of spatial planning.
- von Richthofen, A., Knecht, K., Miao, Y., König, R., 2018. The ‘Urban Elements’ method for teaching parametric urban design to professionals. *Frontiers of Architectural Research*. <https://doi.org/10.1016/j.foar.2018.08.002>

DYNAMIC AGGREGATION

Merging Aggregation and Particle-Spring Systems in a Form-Finding Approach

GONZALO VEGAS, FRANCISCO CALVO

Universidad Técnica Federico Santa María, Chile

Email address: Gonzalo.Vegas.13@sansano.usm.cl

Email address: Francisco.Calvo@usm.cl

AND

MARCELO BERNAL

Perkins&Will, USA

Email address: Marcelo.Bernal@perkinswill.com

Abstract. We present the Dynamic Aggregation model: a form-finding tool to generate volumes with an active interior from a set of surfaces. We offer a novel approach to form-finding by combining two models: Particle-Spring Systems and Discrete Aggregation. Dynamic Aggregation allows the designer to generate emergent results while granting real-time control of the general topology in an interactive physics system. To do so, we built our model from a graph structure composed of Nodes and Links with a local notion of orientation. It allows the model to aggregate, bifurcate, link, and unlink continuously, starting from an initial Node configuration until reaching a target surface, while keeping the Node organization in the process. We test the model in two abstract scenarios and three architectural typologies with distinct topological and geometric features to display differentiation, adaptation, and control capabilities.

Keywords: *Form finding, dynamic aggregation, particle-spring systems, discrete aggregation.*

ملخص. نقدم في هذه الورقة البحثية نموذج التجميع الديناميكي، وهو عبارة عن أداة لاستنباط الشكل لتوليد الكتل المعمارية ذات التصميم الداخلي النشط عن طريق مجموعة من الأسطح. نحن نقدم نهجًا جديدًا لاستنباط الشكل من خلال الجمع بين نموذجين: أنظمة الجسيمات النابضة والتجميع المنفصل. يسمح التجميع الديناميكي للمصمم بتوليد نتائج ناشئة مع منح التحكم في

الوقت الفعلي للطوبولوجيا العامة في إطار نظام فيزيائي تفاعلي. للقيام بذلك، قمنا ببناء نموذجنا من هيكل رسم بياني يتكون من عقد وروابط مع مفهوم محلي للتوجيه. يسمح للنموذج بالتجميع والتشعب والربط وفق الارتباط بشكل مستمر، بدءًا من تكوين العقدة الأولى حتى الوصول إلى السطح المستهدف مع الحفاظ على تنظيم العقد. نقوم باختبار النموذج في سيناريوهين مجردين وثلاثة أنماط معمارية ذات سمات طوبولوجية وهندسية مميزة لعرض قدرات التمايز والتكيف والتحكم.

الكلمات المفتاحية: استنباط الشكل، تجميع ديناميكي، أنظمة الجسيمات النابضة، التجميع المنفصل.

1. Introduction

This research seeks to expand current disciplinary debates right in line with Carpo's definition of the "Second Digital Turn" (Carpo, 2014), arguing in favor of a fundamentally discrete computational approach but endowing it with new capabilities in terms of adaptability and control. Our model combines two opposed techniques: static aggregation of discrete parts and dynamic simulation of particles. The first one is a bottom-up design approach that starts from a single unit and adds similar units through iterations. On the other hand, the dynamic simulation starts from particles that evolve into a new organization through iterative movement. We merge these techniques to obtain a new type of generative process.

Discrete Aggregation adds parts by proliferation. It starts from a single part and then aggregates similar units with different orientations. The designer obtains highly differentiated outcomes with the same initial condition by modifying the parts' arrangement parameters since small changes trigger a completely different result. Several researchers explored this generative approach. While Narahara (2009) searches for universal units for adaptable architecture, Retsin (2016), Rossi and Tessman (2017) integrate design and fabrication with discrete modular units, which also translates into an open-source plugin. Nevertheless, the minimal modifiability of the part itself limits the flexibility of the models.

The Particle-Spring System is a technique pioneered by Frei Otto, later applied in structural form-finding by Kilian and Ochsendorf (2005). This strategy represents particles in a physical system as Nodes and Links connecting two Nodes within a predefined distance threshold, or Springs. Each Spring applies force in its particles in successive iterations until reaching an equilibrium state. This approach implies a top-down generation process with geometric transformation but no topological change. Tenu (2010) approached this problem in the past in the standardization of minimal surfaces for fabrication. Further exploration of this problem applied a similar technique called Cellular Growth.

DYNAMIC AGGREGATION: MERGING AGGREGATION AND PARTICLE-SPRING SYSTEMS IN A FORM-FINDING APPROACH

Cellular Growth is a biomimetic technique based on cell reproduction to generate a geometric proliferation. A point cloud represents a set of cells. It continuously adds new cells between cells that are too far apart, such as in the lightweight installation design of Klemmt and Sugihara (2018). The Links between Nodes are updated continuously according to proximity, which implies significant differentiation in exchange for lesser organization and control. Nevertheless, the model only works on surfaces by expanding the boundary outwards (Klemmt et al., 2019) or inwards (Kalantari & Saleh, 2017). This approach can also not produce results with significant boundary or topological differentiation, such as discrete aggregation. It lacks an organizational structure to maintain control in the model, such as the Particle-Spring System. Since Discrete Aggregation allows the emergence of the geometry and differentiation of the topology but lacks control and adaptability, we propose a new approach by decomposing the aggregation into several steps and integrating Particle-Spring Systems to enhance the adaptability during the dynamic proliferation of Nodes.

The next sections introduce the methodology describing the model based on the manipulation of topology and forces. Later we apply the model in a test case in abstract scenarios and three architectural typologies to explore the model capabilities and potential applications. Finally, we discuss the strengths and weaknesses of the strategy and its theoretical implications.

2. Methodology

Our model's objective is to connect multiple target surfaces from an initial surface composed of a set of Nodes and Links. The Nodes are pulled towards the targets while Links keep them together within a certain distance. When the gap between Nodes exceeds the predefined threshold, the model adds a new Node. The process continues until reaching the Target and achieving an equilibrium state (Figure 1). The outcome is a stereometric volume produced by the Links connecting the Nodes. This generative process relies on two types of resources: topological and force-based. While the topology controls aggregations, the Forces shape the resulting structure. The topology keeps track of neighbor Nodes, and the Forces continuously adjust the positions of Nodes in a self-organizing fashion. This second resource is based on a Particle-Spring System in which each Node is a particle, and each Link is a spring, with additional Hinge and Planar forces to preserve the organization.

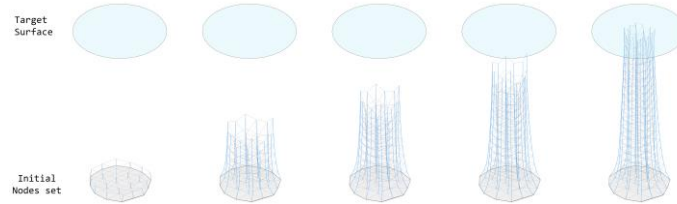

Figure 1. The dynamic Aggregation generation process

2.1. TOPOLOGICAL RESOURCES

The Dynamic Aggregation model includes two classes: Node and Link (Figure 2). While Nodes represent a single point with a list of neighbors, Links represent the horizontal connection between two Nodes. From a global perspective, Links from the same generation step represent the strata. In contrast, the Links between Nodes from consecutive strata represent the columns that maintain the strata together. Each Node classifies neighbors into parent, child, and sibling Nodes. The neighbors are at the bottom, top, and horizontal plane from each Node's local perception. This local orientation differentiates each type of neighbor regarding topological and force resource application.

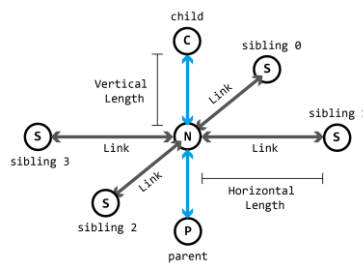

Figure 2. Node's neighbors

The Vertical Aggregation (Figure 3) occurs when the distance between a naked Node and its parent exceeds the Vertical Length Threshold. A Node is naked when it does not have a child Node and is connected to all its sibling neighbors preventing the generation of isolated rows of Nodes. To aggregate, the Node retracts itself towards its parent Node and positions the new Node in its previous location to avoid collision with other geometry. Finally, once the aggregation is complete, all Nodes search for Links to connect. To do so, each Node verifies the child of its parent Node's siblings, as depicted in Figure 4. If a child Node exists, a new Link is created, and the neighbors are updated.

DYNAMIC AGGREGATION: MERGING AGGREGATION AND PARTICLE-SPRING SYSTEMS IN A FORM-FINDING APPROACH

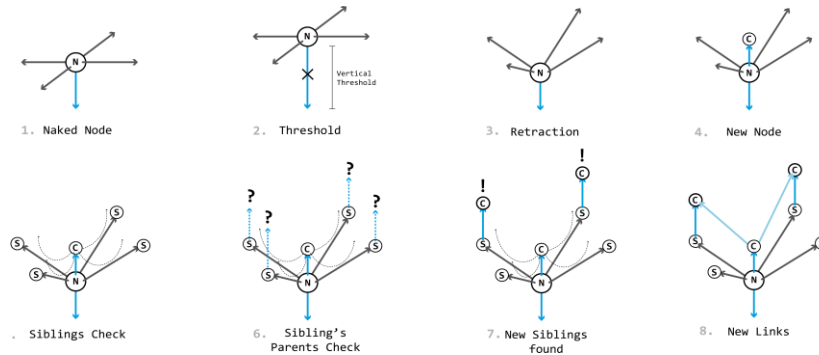

Figure 3. Vertical aggregation (top row) and new links creation (bottom row)

The Horizontal Aggregation (Figure 4) occurs when the length of a Link with naked Nodes exceeds the Horizontal Length Threshold (HLT). The new Node is in the middle point of the Link, and it becomes a child of one of the parents of the Nodes from the Link. Besides, new Links are added to the neighbors in common between the Link Nodes. Like Vertical Aggregation, the horizontal one cannot occur if the Linked Nodes do not have all the connected sibling neighbors. However, unlike Vertical Aggregation, the horizontal is an optional resource and can be activated and deactivated at any moment in the generation process. Finally, if the threshold is exceeded and a Link cannot be produced, the Link will be deactivated not to be affected by forces. However, to allow global bifurcations, deactivated Links keep their topological structure in the background (Figure 5).

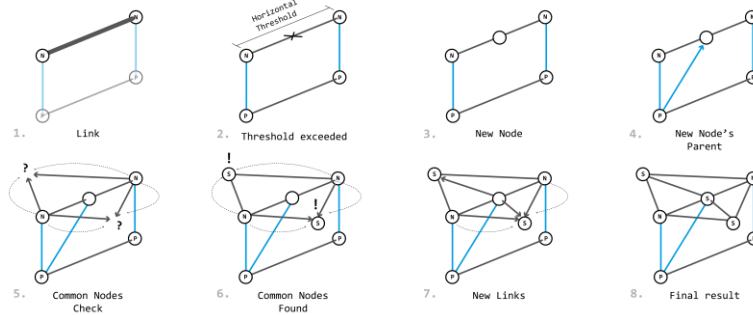

Figure 4. Horizontal aggregation (top row) and new links creation (bottom row)

2.2. FORCE RESOURCES

The main force resources acting in the model are Target forces, Vertical springs, and Horizontal springs. The Target force pulls naked Nodes towards the Target locations, represented as mesh objects. The model starts by associating each Node with a Target. In each iteration, the Target force vector is calculated by finding the closest point in the mesh. Upon arriving, Nodes are snapped to the target mesh, only allowing displacement within the mesh. The Target Factor parameter controls how quickly Target locations attract the Nodes. On the other hand, Vertical and Horizontal spring forces, controlled by Desired Vertical Length (DVL) and Desired Horizontal Length (DHL) parameters maintain these corresponding lengths between the Nodes to preserve stability in the system while avoiding over-constrained movements.

Three optional forces improve model stability: Hinge, Bifurcation, and Planar. The Hinge force keeps the Nodes and the vertical neighbors collinear by applying a force to the Node towards the middle point between its parent and child (Figure 5).

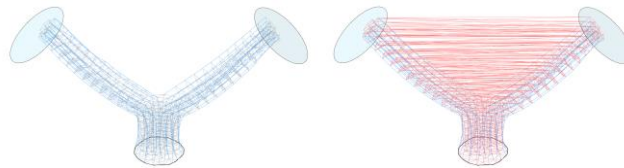

Figure 5. Horizontal aggregation (top row) and new links creation (bottom row)

The Hinge Factor parameter controls the magnitude of the force and how straight Node columns are. When a Node has multiple children, the Bifurcation force is used instead. This force keeps the direction towards the child Nodes (Figure 6). The magnitude is also defined by the Hinge Factor, in this case controlling bifurcation symmetry. Finally, the Planar force pushes the Nodes towards the plane perpendicular to the direction between the Node and its parent (Figure 7). The Planar Factor parameter controls the magnitude of the Planar force and how planar the strata is.

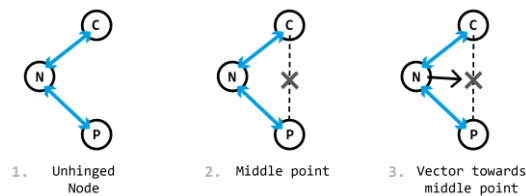

Figure 5. Hinge force calculation

DYNAMIC AGGREGATION: MERGING AGGREGATION AND PARTICLE-SPRING SYSTEMS IN A FORM-FINDING APPROACH

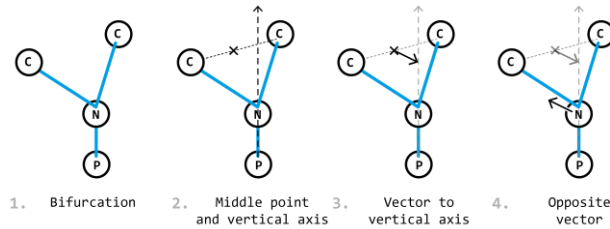

Figure 6. Bifurcation force calculation

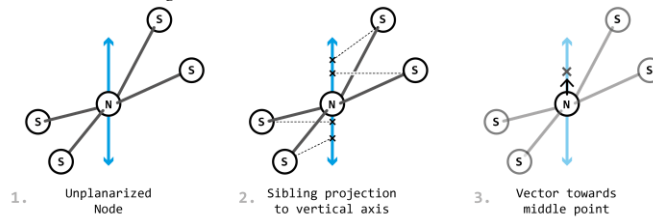

Figure 7. Planar force calculation

2.3. TEST CASE

We tested the model in two abstract scenarios: Branch and Amoeba, and three architectural typologies: Bridge, Tower, and Shed. The objective is to show the influence of the model parameters in the results and display potential applications. For the abstract scenarios, we first generate a simple result, then vary the parameters to obtain differentiation. The model promotes user exploration with real-time feedback allowing parameter changes during the generation process while the Nodes constantly react and update their position. Finally, we generated nine results resembling architectural typologies to display potential design applications.

3. Results

3.1. ABSTRACT SCENARIOS

The Branch and Amoeba scenarios start with Nodes randomly arranged between two and four units apart. Target surfaces are all oriented towards the initial shape center point to facilitate Node arrival, and each Node has a single target surface assigned according to proximity. The generation process begins by applying a Delaunay triangulation to the Nodes. Then, the resulting connections construct Links and define the neighbors. Later, a new stratum of Nodes emerges by an offset of the initial Node set towards the targets,

assigning child and parent to each Node. In this way, each Node has assigned horizontal and vertical neighbors to allow Vertical aggregations to occur.

The branch starts with 40 Nodes in a 30 units diameter perimeter, with five target circular surfaces of 40 units diameter, 100 units from the center and separated 50° apart. The first result (Figure 8) requires minimum Planar force to maintain stability in the strata. An early moment of bifurcation is produced, which is an emergent property of the model. To extend the trunk length, we increase the HLT, so the longest deactivated Links are activated and start applying a spring force to the model. As a reaction, further Links activate until reaching an equilibrium state. Finally, we attempt to expand branch diameter to increase the DHL value and obtain a wider spread result without modifying the previous topology (Figure 9).

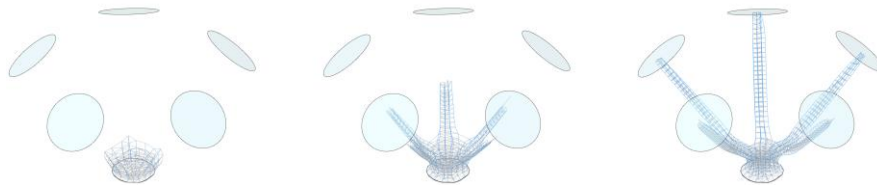

Figure 8. Branch generation process

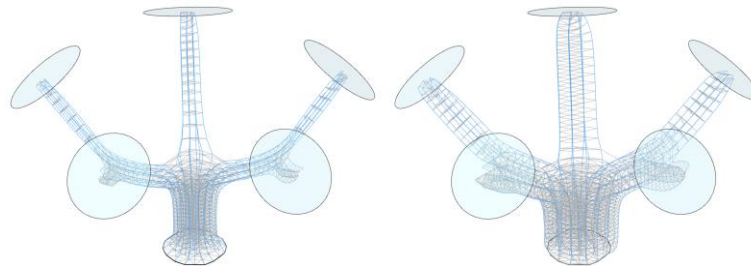

Figure 9. HLT increase (left) and DHL increase (right)

The amoeba starts with 162 Nodes distributed over a 30 units diameter spherical surface with 20 circular target surfaces of 40 units diameter, 100 units away from the center and separated 41.8° apart. The first result produces slender branches (Figure 10) due to the low proportion between initial Nodes and Target surfaces. In the second iteration, we increase the DHL value (Figure 11) resulting in a broader spread in the center and producing different spread levels near the targets. Finally, a new result with Horizontal aggregation results in a denser arrangement with higher spread (Figure 12).

DYNAMIC AGGREGATION: MERGING AGGREGATION AND PARTICLE-SPRING SYSTEMS IN A FORM-FINDING APPROACH

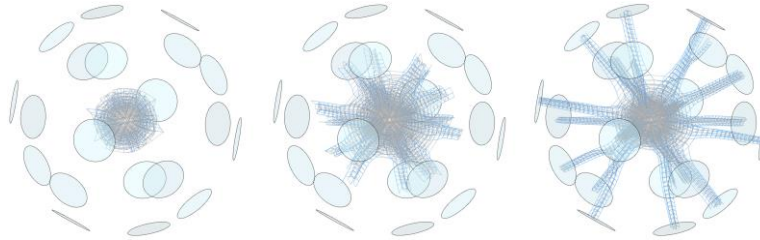

Figure 10. Amoeba generation process

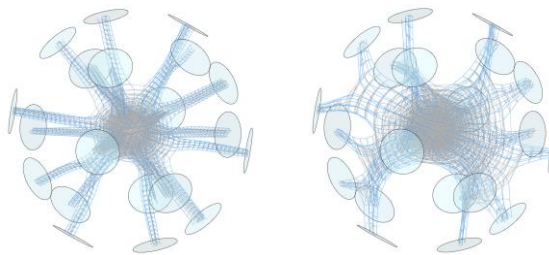

Figure 11. Original result (left) wider result as DHL increases (right)

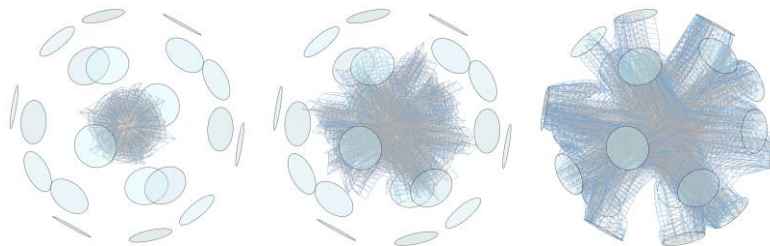

Figure 12. Generation process with Horizontal aggregation

3.2. ARCHITECTURAL TYPOLOGIES

The architectural typologies display potential applications of the Dynamic Aggregation approach. The typologies are compatible with the model capabilities to generate volume-like structures. Unlike the abstract scenarios, this open-ended design process allows more radical differentiations. The studies of the three typologies share the objectives of displaying different levels of slenderness and seek for resulting emergent properties. The Bridge (Figure 13) and Tower (Figure 14) typologies display a similar showcase of the fibers' attachment in different levels to respond to DHL reduction. While the Shed typology (Figure 15) further displays an emergent configuration, as

the starting result has isolated elements merged in a single object in later iterations.

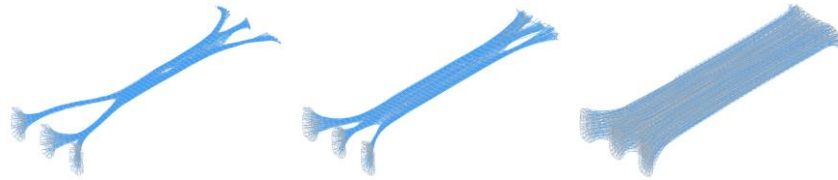

Figure 13. Bridge results



Figure 14. Tower results

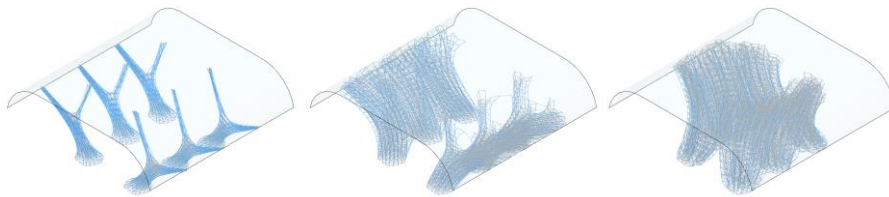

Figure 15. Shed results

4. Discussion

We presented the Dynamic Aggregation model, a form-finding tool composed of topological and force resources to generate a volume from a set of surfaces. The model achieves divergent and convergent geometric proliferation in a continuous aggregation process, with an active volumetric body and a local orientation topology. These factors support a model capable of differentiation, adaptability, and control.

The differentiation is based on the continuous aggregation that produces emergent topological configurations by continually updating the geometry to reach a stable state and avoiding self-intersections. The adaptation relies on the local orientation topology that discriminates between horizontal and vertical neighbors. Thus, the topology remains across the generation process by inheriting Node properties after each aggregation, verified through the strata and columns consistency. The control depends on several resources. The

DYNAMIC AGGREGATION: MERGING AGGREGATION AND PARTICLE-SPRING SYSTEMS IN A FORM-FINDING APPROACH

aggregation division process into steps allows the designer to influence the result with higher resolution. The Hinge and Planar forces increase the direct feedback by allowing the designer to change the intensity at any step of the process. The active volumetric body overcomes Cellular Growth's surface constraint by allowing a freeform voxel-like structure that makes no distinction between interior and exterior geometry and responds in real-time to parameter changes.

The architectural applications displayed through the Bridge, Tower, and Table typologies show emergent configurations and approaches architectural design from a volumetric perspective. Thus, the results suggest materiality as linear components or a fibrous agglomeration. Finally, this research contributes to the discussions regarding the rise of discrete digital paradigm-shifting from continuous to discrete models. It explores the Dynamic Aggregation as an alternative approach for the Discrete in architecture, driven by a more controlled and yet diversified process.

References

- CARPO, M., 2014. Breaking the Curve. Big Data and Digital Design. In *Artforum* 52, pp. 168-173.
- KALANTARI, S. & HASSAN, M., 2017. GrowMorph: Bacteria Growth Algorithm and Design. *CAADRIA*, pp. 479-487.
- KILIAN, A. & OCHSENDORF, J., 2005. Particle-spring systems for structural form-finding. *Journal of the International Association for Shell and Spatial Structures*, Volume 46, pp. 77-84.
- KLEMMT, C., PANTIC, I., GHEORGHE, A. & SEBESTYEN, A., 2019. Discrete vs. Discretized Growth. *ACADIA*, pp. 542-552.
- KLEMMT, C. & SUGIHARA, S., 2018. Architectural Design by Cellular Growth Algorithm. *ALIFE*, Issue 32, pp. 548-549.
- NARAHARA, T., 2009. Bottom-up Design Inspired by Evolutionary Dynamics. *eCAADe*, pp. 391 - 398.
- RETSIN, G., 2016. Discrete Assembly and Digital Materials in Architecture. *eCAADe* 34, pp. 143-152.
- ROSSI, A. & TESSMANN, O., 2017. Geometry as Assembly. *eCAADe*, pp. 201-210.
- TENU, V., 2010. Minimal Surfaces as Self-organizing Systems. *ACADIA* 10, pp. 196-202.

EXPLORING THE SELF-ORGANIZING STRUCTURE OF THE MOROCCAN MEDINA

A simulation model for generating urban form

AQIL CHEDDADI, KENSUKE HOTTA, AND YASUSHI IKEDA
Keio University SFC, Japan
Email address: aqil@sfc.keio.ac.jp

Abstract. This research explores the use of generative design and computational simulations in the exploration of urban compositions based on traditional urban forms from North Africa. Upon the examination of these urban settlements, we discuss the relationship between traditional urban form and generative urbanism theory. We investigate several factors that allow these self-generated urban tissues to be highly adaptive to social, spatial, and environmental change. Following this, we formulate guidelines to reinterpret some of the characteristics of these urban forms. Built on these features, the simulation seeks to explore the generation of abstract urban forms and their optimization. In this regard, this experiment utilizes 3D and parametric design tools (Rhinoceros 3D and Grasshopper) to define a generative urban simulation and optimization model. It explores the use of algorithmic design methodology in the definition and optimization of the generated urban form. For this purpose, grid-based operations with base modules are used in conjunction with introverted urban blocks. We employ evolutionary algorithms and Pareto front methodology to visualize and rank a multitude of optimized results that are evaluated using three different and conflicting design objectives: sun exposure, physical accessibility, and urban density. The results are ranked and analyzed by comparing the outcomes of these different objective functions. The result of this study shows that it is possible to allow a degree of diversification of a myriad of urban configurations with a generative form-finding algorithm while still maintaining a rather commendable adaptability to various design constraints in the case of high-density settings. In this research, it is anticipated that an algorithmic design model is a fitting contemporary solution that can simulate the philosophy of a design made without a designer and offer a wide range of objective-based spatial solutions. It sets the stage for a discussion about the relevance of reinterpreting traditional urban forms

EXPLORING THE SELF-ORGANIZING STRUCTURE OF THE MOROCCAN MEDINA: A SIMULATION MODEL FOR GENERATING URBAN FORM

from north Africa by designing a generative model that allows for self-organization.

Keywords: *Generative urbanism, urban simulation, urban form, multi-objective optimization, algorithmic design, generative design, form-finding.*

ملخص. يهدف هذا البحث الى استخدام التصميم التوليدي (generative design) والمحاكاة الحاسوبية (computational simulations) في استكشاف التراكيب الحضرية القائمة على أشكال المدن العتيقة في شمال إفريقيا. عند دراسة هذه المدن، نناقش العلاقة بين الشكل الحضري التقليدي ونظرية التمدن التوليدي (generative urbanism) العديد من العوامل التي تسمح لهذه الأنسجة الحضرية المولدة ذاتياً أن تكون عالية التكيف مع التغيرات الاجتماعية والمكانية والبيئية. بعد ذلك، يسعى تطوير نموذج وسيطي إلى إعادة تفسير بعض خصائص هذا الشكل الحضري باستخدام نموذج محاكاة حضري. وبناءً على هذه الميزات، تسعى المحاكاة إلى استكشاف توليد أشكال حضرية مجردة وتحسينها. في هذا الصدد، تستخدم هذه التجربة برنامج التصميم الخوارزمي (Grasshopper و Rhino) لتحديد مكونات نموذج التصميم الحضري التوليدي، وتستخدم منهجية التصميم الخوارزمي في تحديد الشكل الحضري المولد وتحسينه. لهذا الغرض، يتم استخدام منهج العمليات القائمة على الشبكة مع وحدات مبسطة تمكن من تكوين كتل حضرية ذات طابع انطوائي. نستخدم الخوارزميات التطورية (evolutionary algorithms) ومنهجية باريتو (Pareto front) لتصوير وترتيب العديد من النتائج المحسنة التي تم تقييمها باستخدام ثلاثة أهداف تصميم مختلفة ومتضاربة: التعرض للشمس، وإمكانية الولوج، والكثافة الحضرية. يتم تصنيف النتائج وتحليلها من خلال مقارنة نتائج هذه الوظائف الموضوعية المختلفة. تظهر نتيجة هذه الدراسة إمكانية الوصول إلى درجة من التنوع لعدد كبير جداً من التكوينات الحضرية باستخدام خوارزمية توليدية لإيجاد الشكل، وذلك مع الحفاظ على قابلية تكيف مع قيود التصميم المختلفة في حالة الإعدادات عالية الكثافة، وهي قابلية جديرة بالثناء إلى حد ما. في هذا البحث، من المتوقع أن نموذج التصميم الخوارزمي هو يمثل حلاً معاصراً مناسباً قادراً على محاكاة فلسفة التصميم بدون مصمم، وتقديم مجموعة واسعة من الحلول الفضائية القائمة على أهداف محددة. وفي هذا السياق، فإنه يمهّد الطريق للنقاش حول أهمية إعادة تفسير الأشكال الحضرية التقليدية من في شمال إفريقيا من خلال تصميم نموذج توليدي يسمح بالتنظيم الذاتي.

الكلمات المفتاحية: العمران التوليدي، المحاكاة الحضرية، الشكل الحضري، التحسين، التصميم الحاسوبي، التصميم التوليدي، إيجاد الشكل.

1. Introduction

1.1. GENERATIVE URBANISM

Urban tissues can be depicted as complex systems (Batty, 2007; Salingaros, 2000) that are a combination of intertwined components that can be understood by going from the single component to the larger whole: It finds its morphological expression in its spatial layout, patterns, and typology of buildings. As discussed by Alexander's pattern language and generative design theory (Alexander, 1977; Alexander *et al.*, 1987), and later further

developed by Salingeros (2013) the urban form cannot be merely defined with a hierarchically descriptive structure but rather with a more intuitive and generative system of representation. Generatively produced urban settlements are often characterized by their adaptability and capacity for evolving through time and space. Although successful examples of generative urban design are quite rare in contemporary developments, it is rather common to find examples in ancient cities predating the 20th century, as they are generatively produced by default (Billig, 2018).

To describe the urban space in a generative manner, several conceptual analysis tools defined urban typology by its process, structures, and pattern language. For instance, Hillier's (1984) Space Syntax preconized that a behaviorally oriented morphological analysis of urban tissues is more prone to offer optimized accessibility and social happenings when compared to conventional design tools. Other design methodologies such as Duarte's application of urban shape grammars (Duarte and Beirão, 2011) which use both design and programming to conceive a descriptive language that allows for the interpretation of existing spaces to create new urban design compositions. More recently, the use of more comprehensive methodologies such as "space semantics" (Yap *et al.*, 2019) tries to represent urban space through numeral descriptions that can allow for the interpretation of an existing space.

While this research considers the urban space as a complex system that can be described through comprehensive models, this paper discusses the use of generative design and Multi-Objective Evolutionary Algorithms (MOEA) to generate abstract urban forms that reinterpret key features of site-specific urban characteristics. In this case, the computational design will be applied to generate optimized urban definitions formulated on principles that reinterpret some of the characteristics of the morphology of ancient north African cities.

1.2. THE MEDINA URBAN MODEL

The following experiment uses the traditional urban developments in North African cities, namely in Morocco as a case study. As is the case with North African and Mediterranean traditional cities, Moroccan medinas (Figure 1), these spontaneous urban tissues are characterized by their adaptability and incremental evolution through time. While it is perhaps easy to argue about the consistency of the Arab-Islamic city form throughout history, as it was pointed out (O'Meara, 2007) for the case with north African medina-type cities, it is a much bigger task to define the founding logic for the organization and of its space it in a thorough way.

Concurrently, Bianca (2000) explains that although Moroccan medinas such as the medina of Fez is nowadays mostly constituted of old and saturated urban tissues, its space is a historic telltale of city growth that reflects a local

EXPLORING THE SELF-ORGANIZING STRUCTURE OF THE MOROCCAN MEDINA: A SIMULATION MODEL FOR GENERATING URBAN FORM

social and cultural identity to North African settlements. While at first glance, the medina of Fez may seem as simple as the manifestation of a chaotic and disorganized development that echoes an aimless labyrinth, but a set of fundamental principles of Muslim culture defines its space (Hakim, 1986), consequently, making it more representative of an organizational logic to which the urban space abides by.

Accordingly, the medina-type city is produced in an intuitive albeit procedural manner. This is especially clear when considering that north African countries, which share mostly the same socio-cultural and environmental setting, and hence the same set of spatial organization principles have an essentially similar urban morphology (O'Meara, 2007). This type of traditional urban fabric reflects a living style that is ordered to shape the spatial interpretation of Islam and its adaptation to local environmental and social factors.

Beyond a mere description of its urban form, the use of generative design theory has allowed us to better grasp the logic that defines its growth and understand the process of it. It was with Hakim's work on Arabic-Islamic cities (1986) on the study of the impact of scriptures on the organization of urban space, that the founding principles behind its self-organization were pointed out in a manner more relevant to the problem solving of urban-related issues. Through his study on traditional Mediterranean urbanism, Hakim (2014) pointed out that several adaptable building rules are responsible for producing generative urbanism throughout pre-modern times. These urban rules and processes, although not necessarily applicable for all contemporary developments, provide valuable lessons for the practice of generative design if reinterpreted carefully (Hakim, 2019).



Figure 1: Google Earth Satellite view of the old Medina of Fes, Morocco.

1.3 RE-INTERPRETING THE MEDINA

Considering the high qualities that the medina model can offer in terms of adaptability, resiliency, and flexibility of space through multiple generations, many contemporary planners and designers are tempted to replicate the characteristics of these settings in their designs. This infatuation was not always present among designers, in fact, for a long-time, medinas were stigmatized as being backward and against the modern values that many Arab rulers were exhorting (Hakim, 2001). While there is a clear divide between modern developments and their traditional counterparts, some of the current developments have considered assimilating traits of Arab/Islamic architecture and urbanism into their design, this integration can often either result in mere “mimicking” if it is not re-interpreted within its context (Radoine, 2017).

Considering that besides a few works of literature, the re-activation of rules relating to Arab/Islamic cities organization is still a poorly defined framework, we suggest three main guidelines to conceive this kind of space (Cheddadi *et al.*, 2019). First is the morphology, which has to offer room for evolutive growth while being compact by being low-rise and of high-density, in addition to being introverted and open on the inside, thus allowing for a form that favors highly mixed spaces. The second is the organization, which is achieved through the bottom-upping of neighboring interactions. Its growth is achieved through the incremental combinations and trading of spaces that change to meet the needs of the users, thus allowing for self-organization and emergence. Lastly, the community, which has a strong emphasis on the use of private spaces. The urban space is formed by its urban function, which is also reflective of the functions of its communities, this can allow for highly mixed and cohesive urban spaces.

While this paper aims to use urban simulations as a tool to explore new definitions of the medina morphology, the incorporation of the community guideline is beyond its scope. Moreover, the guidelines described above are some of the key factors that can describe the Islamic city, but they are far from being all-encompassing. With the use of computational design tools and strategies, we are seeking to integrate these guidelines with form-generation rules and processes that can fit them into an urban development model. For this, this research aims to experiment with the use of simulation tools, to incorporate urban form-finding processes that include traits of the medina morphology, and explore their adaptability, diversification, and evolution in the face of design constraints.

2. The Experiment

2.1. OBJECTIVES AND CONSTRAINTS

The main outcome of this experiment is to propose a generative urban model that can explore conceptual solutions for high-density and low-rise urban forms that can be employed in social housing contexts. The use of an MOEA and Pareto front methodology has already shown the potential for solving problems related to social housing constraints (Aksoy *et al.*, 2015), for the design of “social and cultural orientated urban tissues” (Choi *et al.*, 2020), and the exploration of urban block variations (Navarro-Mateu *et al.*, 2018). The simulation model will be considering a few evaluation factors, some of which will guarantee a degree of environmental comfort and street accessibility for the same target density. This model conceives a tool that can show a multitude of different potential spatial outcomes to be considered by designers and/or stakeholders. This simulation aims to demonstrate, that the medina form has a certain ability for adaptability to environmental and morphological factors through an evolutionary process done through computational design. This is to be validated by consideration of both the exploration (diversification of results) and exploitation (optimization of results) of the urban form; which shows a global trend of diversification of solutions (Makki and Showkatbakhsh, 2018). As a result, the optimization of a large number of urban morphologies is achieved while also allowing for the volatility of users and designers by way of compromised choices available with the Pareto methodology.

2.2. PREVIOUS ITERATIONS

Previous work was concerned about spontaneous urban tissues in Morocco, which studied the distinctiveness of slums that are known for their self-organization (Cheddadi, 2018). It took a slum in Rabat city as a use case for a simulation employing an MOEA strategy by using Octopus, which aims to optimize high-density urban settings in the face of environmental and physical constraints. The results were proposed as an alternative rehousing model for slums, which can offer room for a tradeoff between objective evaluation criteria. Based on the same simulation framework, a second parametric model sought to reinterpret certain characteristics of medinas and examine them with a more analytically oriented approach (Cheddadi *et al.*, 2019). The use of MOEA showed that it can propose a “wide range of objective-based spatial

2.3. SOFTWARE TOOLS

The algorithm (Figure 2) was designed with the use of Rhinoceros 3D (Rhino) and its visual parametric plugin Grasshopper (GH). The Sun Exposure data (SE) are integrated by using the Ladybug environmental add-on. As for the form-finding it is conducted using the multi-objective solver add-on for GH named Wallacei X, which is based on the SPEA-2 evolutionary algorithm. Built on multi-objective evaluation functions, Wallacei X carries out an optimization algorithm that explores possible solutions for the best combination of inputs to generate a best-fitting geometry (phenotype). Wallacei X ranks the results of each generation using the Pareto-front method. Finally, the evaluation, selection, and visualization of the solutions were conducted using Wallacei Analytics, an analytical tool for MOEA solvers. that are considerably adaptive to urban contexts”.

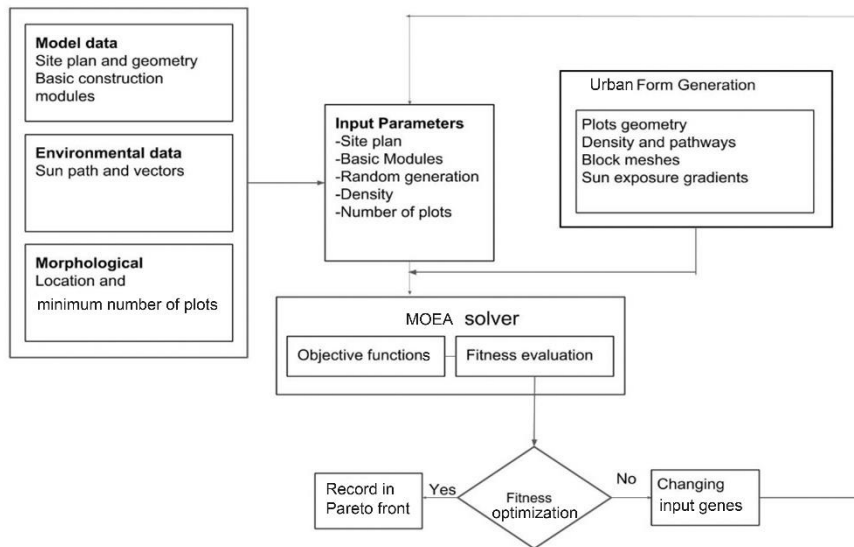

Figure 2. Algorithm flowchart of the parametric model for the urban simulation.

2.4. FORMULATING THE MODEL

While this iteration of the model is formulated using the same guidelines used in the previous one, there is a difference in the phenotypes that are generated, as well as how urban density is defined. The grid-based operations of basic modules are permuted to explore different possible organizational combinations as phenotypes.

EXPLORING THE SELF-ORGANIZING STRUCTURE OF THE MOROCCAN MEDINA: A SIMULATION MODEL FOR GENERATING URBAN FORM

2.4.1 Plot subdivision:

After defining the surface plot, to ensure an organic and non-cartesian shape, a Voronoi GH component is used to divide the plot. Coupled with a surface offset that creates width for the streets.

2.4.2 Grid definition:

A 2D grid is mapped into the plot surfaces, its dimensions can be modified to suit different scenarios. Then, the 2D grid is coupled as an input with a height component in Z-direction that converts it to a 3D component. These represent the dimensions of prefabricated modules that are used for construction.

2.4.3 Introverted blocks:

To ensure that the urban blocks are introverted with courtyard shaped interior openings, the center of each subdivision is designated as an attractor point and assigned a negative value to push the algorithm to favor interior terraces.

2.4.4 Sun vectors definition:

For defining the sun exposure (SE) data, the “Ladybug” environmental plugin within GH was used. We chose the geographic weather profile for Rabat city as a study case. It is loaded into the GH definition to represent, depending on the scenarios, the sun vectors and sun path for the winter or the summer solstice.

2.4.5 Meshing and Color Mapping:

To visualize SE, the resulting modules are merged and put together with a Mesh Union component. The resulting meshes are then color-mapped by using a gradient component that visualizes SE by representing the exposure on any module surface throughout the day.

2.5 SIMULATION DESCRIPTION

The parametric design algorithm is set as a generative model based on factors including exposure to sunlight, physical accessibility, the number of floors, and the urban population density. The GH parametric model is made to follow a data flow that optimizes form-finding. Several GH components are established as genes and coupled together with objective functions for Wallacei X to operate (Table 1).

TABLE 1. Description of the evolutionary solver’s input and objectives.

Genes	<ul style="list-style-type: none"> • Number of subdivisions • Block form variation
Objectives	<ul style="list-style-type: none"> • Higher density • Better sun exposure • Higher connectivity
Phenotypes	<ul style="list-style-type: none"> • Urban block meshes

2.5.1. Evaluation settings

With a total of three objective fitness functions that seek to optimize SE, connectivity, and urban density (Table 1), Wallacei X evaluates each phenotype of 3D geometry to seek better fitness. To avoid any influence on the outcome of the multi-objective optimization, and ultimately the Pareto front line results, the objective functions are equally weighted throughout the simulation. The first fitness objective aims for better connectivity and accessibility, its objective function is a simple numerical value that is the combination of the length of streets and the shortest line from each unit to the nearest street, this value is positively correlated with the number of subdivisions and pushes the solver to favor smaller subdivisions. The second fitness objective is a target range for urban density which, we assume, conflicts with the first since bigger plots also mean higher density. As for the SE objective function, it is set to reward the algorithm if the optimization results are equalized in a range that goes from 3 to 6 hours of sun exposure.

For this simulation, the solver is set to a generation the size of 30 with a generation count of 50 (Table 2).

TABLE 2. A summary of the simulation settings.

Solver Parameters	Description
Generation size	30
Generation count	50
Population size	1500
Crossover probability	90%
Mutation probability	1/n

3. Findings and Analysis

Due to the heuristic nature of the optimization algorithm, it does not conclude with a definite, single optimized solution. Instead, it generates a multitude of

EXPLORING THE SELF-ORGANIZING STRUCTURE OF THE MOROCCAN MEDINA: A SIMULATION MODEL FOR GENERATING URBAN FORM

optimized solutions for conflicting goals. Choosing the right solutions can be challenging for designers and users alike, which is why it is mandatory to use analytical tools, such as Wallacei X Analytics (Makki *et al.*, 2018) that help better navigate the results and make more informed choices. With a considerably huge search space of up to 4.6×10^5 for the MOEA to explore optimized phenotypes, it is necessary to statistically analyze the results. The visual inspection of the solutions (Figure 3) might give an idea about global trends of the algorithm but does not help to better understand the results.

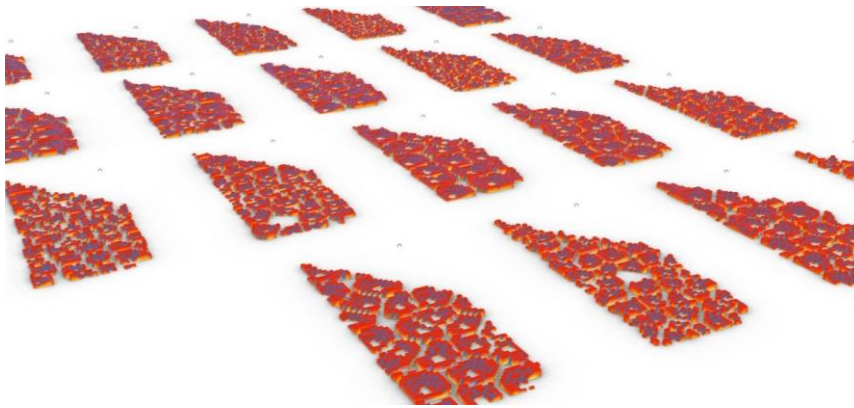

Figure 3. Visualization of meshes of the final generation Pareto frontline rendered on a grid.

The inspection of the fitness values data and standard deviation curves of the Pareto front for the results of the experiment (Figure 4) shows that the genetic solver has shown a trend for optimizing the urban form while keeping enough diversification. In the standard deviation graphs, red represents the first generation, and blue is the last generation. For SE distribution and the density (fitness objectives 2 and 3 respectively), it seems that the result is close to expectations with a spread-out standard deviation that flattens as generations go by; thus, approaching the bell curve in the most SE optimized phenotypes when compared with baseline results outside the Pareto front. Analysis of the data also shows that the algorithm can compromise the global SE score for a better SE equalization result.

While analyzing the data, there is a clear trend for further optimizing the mean value of the evaluation scores for all three objectives while also further spreading out the standard deviation curve. Narrowing the standard deviation graphs through the generations, also seen through the standard value trendline going higher up proves the system's ability to maintain a diversified solution that can prevent any premature convergence of the solver.

However, due to the stochastic nature of the MOEA, the mean value trendline is constantly fluctuating, showing that the algorithm is still favoring the exploration of the objective space rather than its exploitation. As an outcome, we can assert that by utilizing this simulation model, it is possible to use this methodology of generative design to formulate certain types of urban settings based on characteristics of medina-type cities.

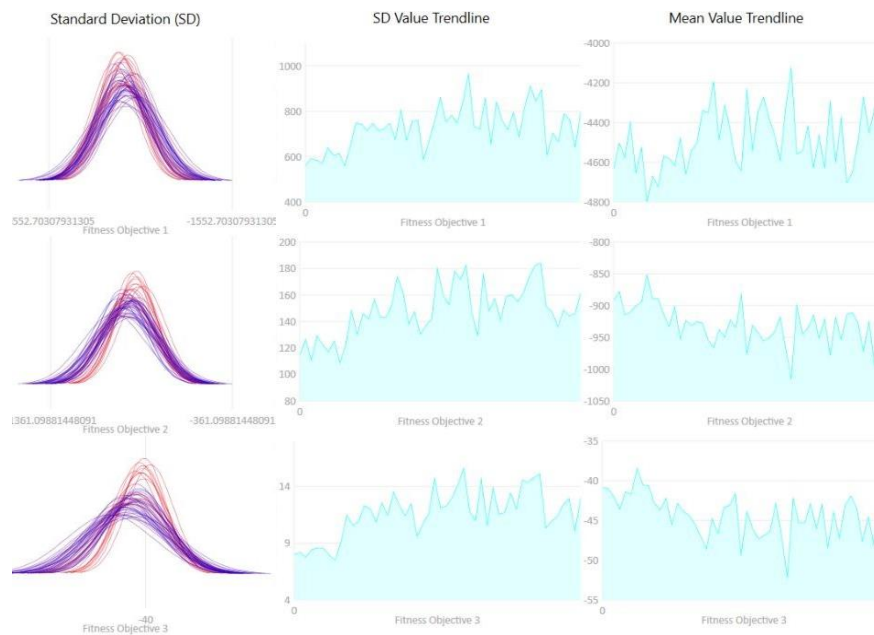

Figure 4. from left to right: Standard deviation, value trendline and mean value trendline for the three fitness objectives. Numbered in the figure from top to bottom: connectivity, density, and SE. The generation count is represented from red to blue.

3.1. SELECTION OF RESULTS

Going one step farther than the study of general optimization trends, it is also crucial in this methodology to select the optimum outputs for the design problem. This is achieved with the exploration of the Pareto front results. After a generation count of 30, the number of solutions represented on the Pareto line is 19. The change and diversification of results have also shown that the solutions represented on the Pareto front have changed throughout the generations. Visualizing the Pareto front results along with their respective data is also important to select the appropriate solutions and comparing any physical discrepancies between the results and the visual forms. Some of the

EXPLORING THE SELF-ORGANIZING STRUCTURE OF THE MOROCCAN MEDINA: A SIMULATION MODEL FOR GENERATING URBAN FORM

first iterations of the model have indeed show inconsistencies between data and generated form, this was caused by a poorly defined evaluation factor which was subsequently revised. Of course, any solution with a specific rank for a fitness criterion for any objective can also be selected and reinstated.

4. Discussion

The intrinsic nature of this kind of parametric model makes it impossible to have a dominant solution. As such, the final selection of a solution to be adopted must be done by other means. While the model might have partially answered to the morphological and organizational factors discussed in the paper, the community one is still poorly defined and evaluated. Comparing and cross-checking, the optimized model with factors external to the multi-objective optimization algorithm can also be methods to evaluate its reliability and adaptiveness. This can also be done through a community design approach in which the inhabitants can take part in the process design and shorten the gap between the design and the users.

As designers, it is no longer about designing the best solution as much as it is about designing a tool that offers the widest range of optimized possibilities for the stakeholders to choose from. Ultimately, MOEAs and Pareto methodology do not specify one most optimized solution, the preference to choose the most suitable one should be up to the people most concerned about the problem.

This study has shown that combining generative design with morphological characteristics of medina-type cities in an optimization simulation can offer a diversity of outcomes, adaptability to constraints, and flexibility in generative rules. While this study aims to take some of the qualities of medina type urban tissues and explore their application for generative algorithms, it also concerns itself with the implications of such an approach. There are clear limitations to the way North African cities were designed in the modern age when considering contextual identity and the need to balance between modernization, rapid growth, and strong demand for housing. Indeed, there are benefits to adopting an Arab-Islamic city form regarding walkability, human scale, and the identity of the urban space. The use of an optimization methodology for urban design ought to offer a spatial solution that could take decades if not centuries of trial and error in the urban environment to reach. It aims to inspire the discussion about new ways to think and design today's North African cities. The authors are hopeful that the rise in the use of algorithmic design and the growing interest in designing cities at a human scale will contribute to more a contextualized contemporary urban design.

Acknowledgments

This research was funded by the Keio University Doctorate Student Grant-in-Aid Program.

References

- Aksoy, Y.B., Çağdaş, G., Balaban, Ö., 2015. A Model for Sustainable Site Layout Design of Social Housing with Pareto Genetic Algorithm: SSPM, in: Celani, G., Sperling, D.M., Franco, J.M.S. (Eds.), *Computer-Aided Architectural Design Futures. The Next City - New Technologies and the Future of the Built Environment, Communications in Computer and Information Science*. Springer Berlin Heidelberg, Berlin, Heidelberg, pp. 113–133. https://doi.org/10.1007/978-3-662-47386-3_7
- Alexander, C., 1977. *A pattern language: towns, buildings, construction*. Oxford university press.
- Alexander, C., Neis, H., Anninou, A., King, I.F., 1987. *A new theory of urban design*. Oxford University Press New York.
- Batty, M., 2007. *Complexity in City Systems: Understanding, Evolution, and Design* 36.
- Bianca, S., 2000. *Urban form in the Arab world: past and present*. Thames & Hudson, London ; New York, NY.
- Billig, N., 2018. *Istanbul: Informal Settlements and Generative Urbanism*. Routledge.
- Cheddadi, M.A., 2018. *Towards a Digital Design Approach For Rehousing Slums: The Case Of Douar Al Garaa in Morocco (Master of Media and Governance)*. Keio University, Tokyo, Japan.
- Cheddadi, M.A., Hotta, K., Ikeda, Y., 2019. Reinterpreting self-organizing urban tissues by designing a generative model, in: *Revisiting the Role of Architecture for Surviving Development. 53rd International Conference of the Architectural Science Association, ANZAScA*. pp. 175–184.
- Choi, J., Nguyen, P.C.T., Makki, M., 2020. The design of social and cultural orientated urban tissues through evolutionary processes. *International Journal of Architectural Computing* 1478077120951948. <https://doi.org/10.1177/1478077120951948>
- Duarte, J.P., Beirão, J., 2011. Towards a methodology for flexible urban design: designing with urban patterns and shape grammars. *Environment and Planning B: planning and design* 38, 879–902.
- Hakim, B.S., 2019. *Urban Rules and Processes: Historic Lessons for Practice*. EmergentCity Press.
- Hakim, B.S., 2014. *Mediterranean urbanism: historic urban/building rules and processes*. Springer, Dordrecht ; New York.
- Hakim, B.S., 2001. Reviving the Rule System. *Cities* 18, 87–92. [https://doi.org/10.1016/S0264-2751\(00\)00060-3](https://doi.org/10.1016/S0264-2751(00)00060-3)
- Hakim, B.S., 1986. *Arabic-Islamic cities: building and planning principles*. New York : KPI, London.
- Makki, M., Showkatbakhsh, M., 2018. Control of Morphological Variation Through Population Based Fitness Criteria, in: T. Fukuda, W. Huang, P. Janssen, K. Crolla, S. Alhadidi (Eds.), *Learning, Adapting and Prototyping - Proceedings of the 23rd CAADRIA Conference - Volume 1, Tsinghua University, Beijing, China, 17-19 May 2018*, Pp. 153-162. CUMINCAD.
- Makki, M., Showkatbakhsh, M., Song, Y., 2018. Wallacei, Evolutionary Engine for Grasshopper3D [WWW Document]. wallacei. URL <https://www.wallacei.com> (accessed 2.8.21).
- Navarro-Mateu, D., Makki, M., Cocho-Bermejo, A., 2018. *Urban-Tissue Optimization*

EXPLORING THE SELF-ORGANIZING STRUCTURE OF THE MOROCCAN
MEDINA: A SIMULATION MODEL FOR GENERATING URBAN FORM

- through Evolutionary Computation. *Mathematics* 6, 189.
<https://doi.org/10.3390/math6100189>
- O'Meara, S., 2007. *Space and Muslim Urban Life: At the Limits of the Labyrinth of Fez*, 1st ed. Routledge. <https://doi.org/10.4324/9780203947074>
- Radoine, H., 2017. *Architecture in Context: Designing in the Middle East*, 1st edition. ed. Wiley, Chichester, W. Sussex.
- Salingaros, N.A., 2013. *Unified architectural theory: Form, language, complexity*. Kathmandu: Vajra Books.
- Salingaros, N.A., 2000. Complexity and Urban Coherence. *Journal of Urban Design* 5, 291–316. <https://doi.org/10.1080/713683969>
- Yap, S., Ha, G., Muslimin, R., 2019. Space Semantics - An investigation into the numerical codification of space, in: M. Haeusler, M. A. Schnabel, T. Fukuda (Eds.), *Intelligent & Informed - Proceedings of the 24th CAADRIA Conference - Volume 2*, Victoria University of Wellington, Wellington, New Zealand, 15-18 April 2019, Pp. 431-440. CUMINCAD.

TOWARDS NEW DESIGN PATTERNS FOR MUSEUM EXHIBITION HALLS USING INTEGRATED ALGORITHMIC GENERATIVE TECHNIQUES

HUSSIEN MANSOUR, SHERIF SHETA, MEDHAT SAMRA

Mansoura University, Egypt

Email address: hussien.mansour.91@gmail.com

Email address: shetash11@yahoo.com

Email address: medhatsat2005@hotmail.com

Abstract. This paper aims to define the concepts, methods and techniques needed to establish a multifaceted, yet comprehensive description of complex problems facing conventional architectural design, and how to decode the problems knots through integration between techniques and technologies in generative algorithmic and its impact of the quality of design solution. To attain these aims, the study explores the ability of integrated algorithmic techniques in developing dealing with complicated problems in the design of museums exhibition halls. It discusses, analyzes, and evaluates several conventional architectural design methods and reviews the challenges that limit their ability to produce creative solutions. This will help close the gap between the design quality and duration of design process; conforming that engineering programs help designers, not marginalize them. And hence developing architectural considerations in the design process to parametric paradigms that are suitable for scientific curriculum. So, the research problem is how such methodology can implement the integration between generative design techniques.

Keywords: *Algorithmic Techniques, Architectural Design, Generative Design, Exhibition Halls, Integrated Techniques.*

ملخص. هذه الورقة البحثية تهدف الى تعريف المفاهيم والطرق والتقنيات المطلوبة لإنشاء وصف متعدد الأوجه وشامل للمشكلات المعقدة التي تواجه التصميم المعماري التقليدي وكيفية فك عقد المشكلات خلال التكامل بين التقنيات والتكنولوجيات في الخوارزميات التوليدية وتأثيرها على جودة الحل التصميمي. للوصول الى هذه الأهداف، تستكشف الدراسة قدرة التقنيات الخوارزمية المدمجة في تطوير التعامل مع المشكلات المركبة في تصميم قاعات العرض المتحفي. تناقش الدراسة وتحلل وتقيم عددا من أساليب التصميم المعماري التقليدي وتستعرض التحديات التي تحد من القدرة على انتاج حلول مبتكرة. يساعد هذا في سد الفجوة

TOWARDS NEW DESIGN PATTERNS FOR MUSEUM EXHIBITION HALLS USING INTEGRATED ALGORITHMIC GENERATIVE TECHNIQUES

بين جودة التصميم والمدة الزمنية للعملية التصميمية للتأكيد أن البرامج الهندسية تساعد المصممين ولا تهمشهم. ومن ثم تطوير الاعتبارات المعمارية في العملية التصميمية إلى نماذج بارامترية مناسبة للمناهج العلمية. لذا فإن المشكلة البحثية هي كيف يمكن لهذه المنهجية أن تتفقد التكامل بين تقنيات التصميم التوليدي.

الكلمات المفتاحية: التقنيات الخوارزمية , التصميم المعماري , التصميم التوليدي , قاعات العرض , التقنيات المتكاملة.

1. Introduction and Research Context

The major design challenge has no longer been the lack of data and information which are now made available and accessible, but lies in how to deal with this amount of information; especially with the complexity of the functional design problems. These complex architectural problems are due to contemporary requirements for the different applications in architecture that make it more difficult - and sometimes impossible - to solve with use of conventional methods. The old design systems are based on intuition and innovation, which mainly focuses on the technical capabilities and creativity that are based on subjective experience and skills equipped with a potential series of try and error. Hence, integrated smart techniques and technologies are needed to provide design exploration and creative solutions. In this paper we used Grasshopper, which is a visual programming editor, integrated within the NURBS-based 3-D modeling environment of Rhinoceros (Rhino).

Algorithmic systems are defined to illustrate how to project this method in architectural design, through reviewing techniques and technologies in algorithmic design that integrated together and adaptive with the fluctuations of the conditions. This paper investigates this question through a review of five different generative design techniques most used in architectural design that includes L-systems (LS) (A Lindenmayer, 1968), Cellular Automata (CA) (von Neumann, 1951; Wolfram, 2002), Genetic Algorithms (GA) (Holland, 1975), Shape Grammars (SG) (Stiny, 1980) and Swarm behavior (SB) (Deneubourg, 1977; Payman, 2004).

Exhibition halls in museum are subject to many overlapping and integrated factors like lighting, ventilation, forming, the mechanism of visitor's circulation and their interactions with exhibits, how to design the distribution of exhibits and the structural system that serve this distribution, etc. All these factors and problems interact with each other to bring out different design patterns, using integrated algorithmic generative techniques aims to create perfect, different and creative design patterns through prioritizing factors according to environmental and design data and choosing the best solutions for each factor separately; considering the inputs and outputs of the other factors to create many generations of solutions and choose the optimum.

This study explores how much techniques and technologies integrated from algorithmic systems can stimulate creative methods to solve contemporary complicated problems in the design of museums exhibition halls, that old ones fail to optimize.

2. Literature review of selected generative design techniques (GDTs)

In the following, the literature review focused on technical aspects of each GDT and confined to their application to architecture design. The aspects are history and background, system: introducing main ideas and concepts, components: discussing how each system might be structured, units: showing the units' types that a system can recognize and deal with, control space: commenting on some prosperities of each system, grammars: showing how each system works, its behavior or rules, representation: discussing how each design component and units are represented, techniques-based: how new techniques emerge from father.

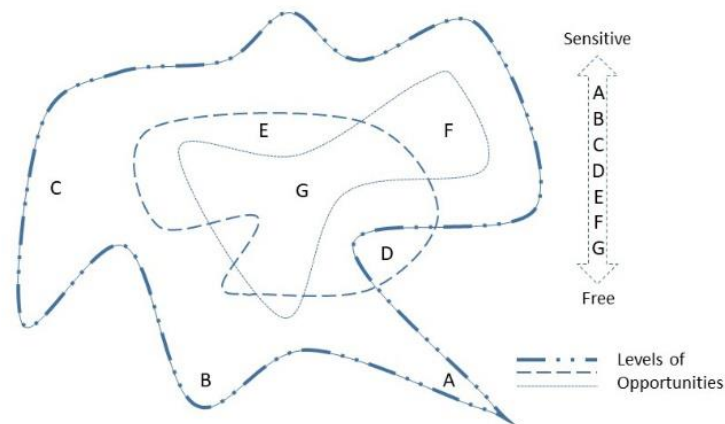

Figure 1: Operation opportunities through different levels.

Figure 1 represents the range of operation, differences and complexity of their situations, whereas each one has a special status of freedom that forces the operation to take certain rules that are appropriate to this situation. These rules range from emergence, replacement, simulation, transformation, deformation, etc. Example (A) present a region with highly complex restrictions, very narrow space and one level of movement, hence the operation takes special grammars in dealing with this situation. In contrast (G) has weak restrictions and greater freedom. Despite the different circumstances and limitations, this does not mean the difficulty of solutions, but only to categorize cases. The later usually known as a rule-based algorithm according to Terzidis's interpretations (Terzidis, 2006, pp xi-xv).

TOWARDS NEW DESIGN PATTERNS FOR MUSEUM EXHIBITION HALLS USING INTEGRATED ALGORITHMIC GENERATIVE TECHNIQUES

2.1. L.SYSTEM (LS)

L-Ss are one of algorithmic generative techniques with rule-based systems and parallel methods of Derivation (Chosmsky, 1985), its primarily a set of production rules applied recursively through string rewriting (Minsky, 1967), therefore it has been distinguished from design grammars as being operated on strings. LS needs axioms, rules and initial strings as a few components to solve problems, therefore it is very easy to implement. Solution Space in LS can be expressed as follows: Number of generations X String length X Number replacing symbols sets (Hansmeyer, 2003).

It needs one type of units: Alphabets with no inheritance between them, low constraints and high associativity between alphabets, each unit include one value (Parish & Muller, 2001). To visualise or evaluate the generated design, these populated strings are 'remapped' into appropriate forms through graphical interpretations; like Turtle graphics. These strings would be deterministic, non-Deterministic, context-Free and context-Sensitive (El Khaldi, 2007, p56).

2.2. CELLULAR AUTOMATA (CA)

CA is a collection of cells on a regular grid of a specified shape - each in one of a finite number of states, such as on and off - that evolve over time according to a set of rules driven by the state of the neighboring cells (Neumann V, 1951; Wolfram S, 2002). Cellular Automata were best known as generative systems for image processing and image generation, using for simulates reproduction behavior by sequentially applying Replacement-Hierarchal rules to the cell and its neighborhoods (Batty M., 2005). According to Conway (Martin, G., 1970); rules determine who survives, dies, or is born in the next generation, and use a cell's neighborhood to determine its future. The embedded rules may change the definition of the neighborhoods in each level of generation (Krawczyk R., 2002).

2.3. GENETIC ALGORITHM (GA)

In computer science and operations research, a GA is a metaheuristic inspired by the process of natural selection that belongs to the larger class of evolutionary algorithms (EA) (Gero & Kazakov, 2001). Genetic algorithms are commonly used to generate high-quality solutions to optimization and search problems by relying on biologically inspired operators such as mutation, crossover and selection (M. Mitchell 1996). In a genetic algorithm, a population of candidate solutions (called individuals, creatures, or

phenotypes) to an optimization problem is evolved toward better solutions (Ding & Gero, 2001). Each candidate solution has a set of properties (its chromosomes or genotype) which can be mutated and altered; traditionally, solutions are represented in binary as strings of 0s and 1s, but other encodings are also possible (Salge, C., et al., 2008)

2.4. SHAPE GRAMMAR (SG)

A SG consists of shape rules and a generation engine that selects and processes rules. A shape rule defines how an existing (part of a) shape can be transformed. A shape rule consists of two parts separated by an arrow pointing from left to right (Tepavcevic & Stojaković, 2012). A shape grammar minimally consists of three shape rules: a start rule, at least one transformation rule, and a termination rule (George S., 2006). The critical challenge in developing a grammar is to produce designs that meet the design goals or constraints (Knight, T. 1998, 1999).

2.5. SWARM BEHAVIOR (SB)

SB, is a collective behavior exhibited by entities, particularly animals, of similar size which aggregate together, perhaps milling about the same spot or migrating in some direction (Bouffanais, Roland, 2016). SB provides a basis with which it is possible to explore collective or distributed problem solving without centralized control or the provision of a global model (Singh V. & Ning G. 2011). An agent-based model (ABM) is a class of computational models for simulating the actions and interactions of autonomous agents - both individual and collective entities such as organizations or groups - with a view to assessing their effects on the system as a whole (Grimm, Volker; Railsback, Steven F. 2005). Bonabeau, Dorigo, and Theraulaz (1999) explain a swarm in terms of self-organisation and stigmergy. Self-organization is a process where some form of overall order arises from local interactions between parts of an initially disordered system. Stigmergy is a mechanism of indirect coordination, through the environment, between agents or actions. The principle is that the trace left in the environment by an individual action stimulates the performance of a succeeding action, possibly by the same agent, but in many scenarios by a different agent.

Figure 3, shows the location of techniques in the algorithmic space by classifying systems, L-systems are located-in the intersection of parallel application and replacement rules. CA is located-in the sequential one. SG can be located-in_Parallel, Sequential or Random zones. SB can be located-in the replacement rules. GA can be located-in the intersection of replacement (by embedding) and hierarchical rules.

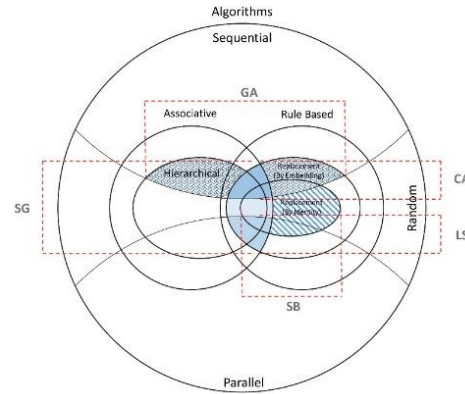

Figure 3. Generative Techniques according to its behaviors, based on El K haldi M. 2007.

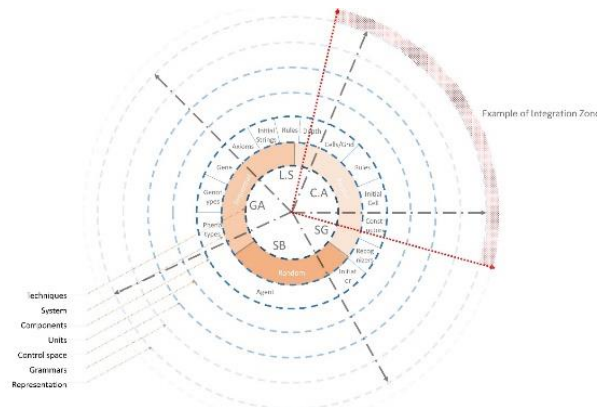

Figure 4. Methodology integration between technical based aspects, with summary of selected G.D.T., developed by the authors.

CA, LS and SG are generally represented in graphical forms that result from transformations and operations (i.e., addition, rotation, subtraction, etc) on the initial elements (Coates, 2004; Coates & Carranza, 2000), whereas the patterns from SI generally result from the autonomy of the agents (e.g., where agents act on the environment such as nest building) or by plotting the agent activities (e.g., tracing agent's way-finding trail) (Thalman et al., 2004; Yoon & Maher, 2005). Figure 8; paves the way for the methodology of integration between the various techniques. Figure 4.

4. Integration Process Methodology

The existing GD systems lack flexibility in supporting such reflective practice because each system is most often developed based on a single GD technique,

TOWARDS NEW DESIGN PATTERNS FOR MUSEUM EXHIBITION HALLS USING INTEGRATED ALGORITHMIC GENERATIVE TECHNIQUES

constraining the design exploration opportunities to the design generation path offered by the specific GD technique (Singh V. & Ning G., 2011). The proposed methodology aims to develop system based on multiple GD techniques. The software user can define and add any GD technique that can help in his case study through this methodology. This is an experimental methodology that can help support design exploration and expand the range of solutions, inside Rhino\Grasshopper, the user should define the inputs and redefine the outputs, who is also the tool builder. Plug-ins used here is compatible with the research objectives, but the user can apply any plug-in compatible with the methodology. The process formulate and transform the problem represented in one GD technique to another, for example, from CA to SB, and so on.

The optimization process is applied on all stages to help software user to select optimum solution in each step. Silvereye (Cichocka J., & others, 2017) plug-in is used in the methodology which implements Particle Swarm Optimization (PSO). It is dedicated for single-objective searches and can be used for solving complex, real-world optimization problems in the design space, as the algorithm is hypothesized to be fast and intuitive. The loop process can be repeated by the user.

Figure 5 presents the integration methodology applied on museum exhibition halls to expand design exploration and create new design patterns through experiment proposals. Exhibition halls are distinguished with the diversity of inputs, design philosophy, functionality and volumes. This diversity is one of the most important reasons for choosing this type of building to explore the maximum benefits of the outputs from the integration, with the possibility of applying the methodology to various building types.

4.1. EXHIBITS POSITIONS

This section presents exhibits in this type of building are the most important element, so identifying its positions is the first step, accordingly, user behavior and interaction, the size of the exhibition and the type of construction system used are determined. Exhibits are cells that have characteristics, sizes and spaces, and their places change and evolve over time to meet the requirements of the display. CA is a collection of cells on a grid that evolve over time according to a set of rules driven by the state of neighboring cells, life cells present exhibits and dead cells present users' paths. Using Rabbit¹ to apply this technique, it is an open-source plug-in for Grasshopper that simulates biological and physical processes. The User can define another technique and another plug-in based on research objectives and requirements. Optimization process are applied to select optimum solution.

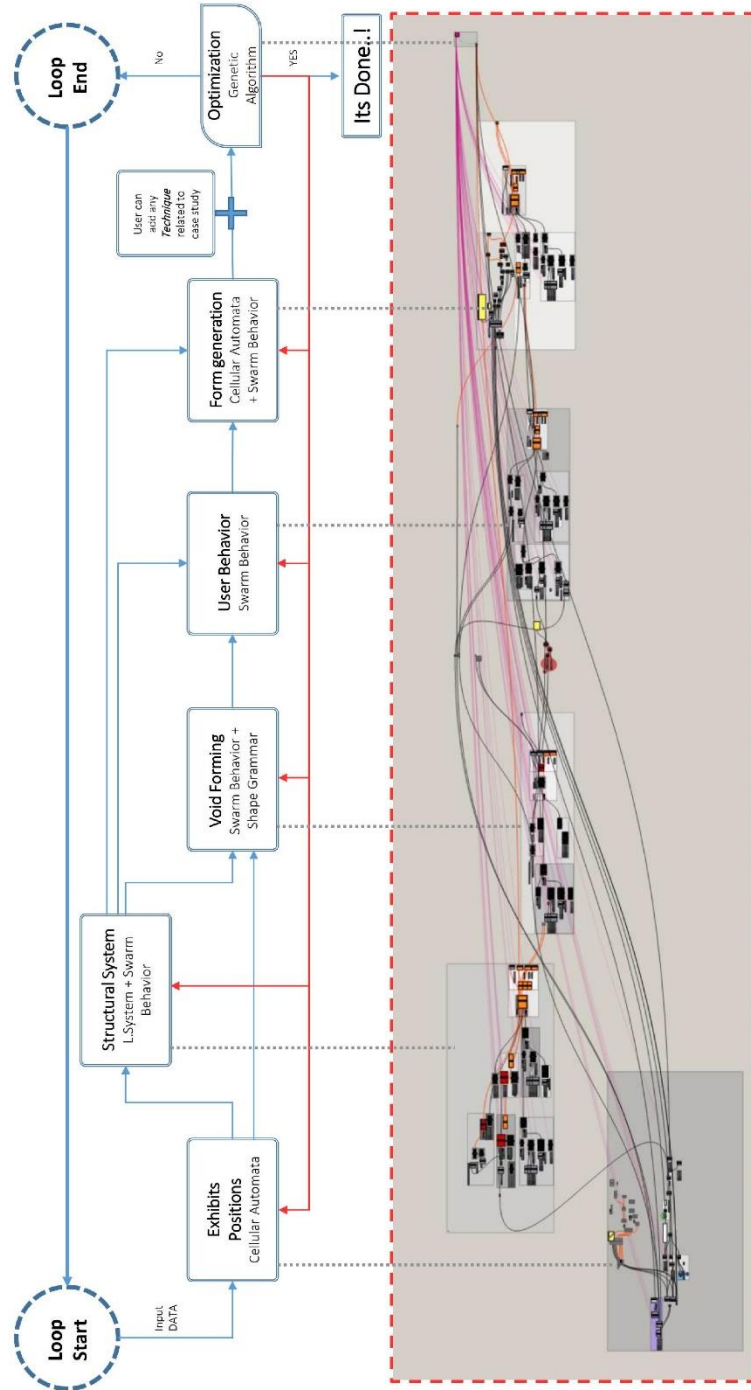

Figure 5. Integration process methodology.

TOWARDS NEW DESIGN PATTERNS FOR MUSEUM EXHIBITION HALLS USING INTEGRATED ALGORITHMIC GENERATIVE TECHNIQUES

4.2. STRUCTURAL SYSTEM

According to the result from Exhibits positions stage, the positions have been identified, these places are inputs in the stage of the structural system, and due to the complexity of the structural system methodology, and swarm intelligence and L.System are used to create experimental solutions for the methodology and not as a final product. SI provides a basis with which it is possible to explore collective or distributed problem solving without centralized control or the provision of a global model. Using Culebra² to apply this technique, it is a Multi Object Behavior library written in C# focused on hybrid system interactions with custom visualization, data, and performance features. It contains a collection of objects and behaviors for creating dynamic multi agent interactions. LS are primarily a set of production rules applied recursively through string rewriting. Using Rabbit to apply this technique.

4.3. VOID FORMING

This section presents the internal interactive spaces are based on the positions of the exhibits and the structural system, the main lines of these spaces are inputs for the next stages. The goal is to generate design language of these lines and shapes, Shape grammar technique used as a design tool with Swarm Intelligence to understand the rules that can be applied. Using SortalGI³ to apply SG, it supports the specification and application of both parametric and non-parametric shape rules and the generation of single or multiple rule application results.

4.4. USER BEHAVIOR

Users behavior cannot be controlled but rather can be tamed and make it interactive, with all the previous inputs like exhibits positions, structural system and internal interactive spaces. It can affect and be affected by the user's behavior according to various parameters such as time of the visit, visitors ages, weather, size of the exhibit and number of visitors. Predicting and measuring this behavior using SI, optimization process determines the best behavior regarding all inputs.

4.5. FORM GENERATION

The inputs are void lines subtraction, structural lines addition and swarm behavior lines. CA will simulate in 3d based on exhibits positions (life cells), the output generates the form using swarm intelligence SI and optimization process determine the best void and form that achieving the methodology.

1. <https://morphocode.com/rabbit/>
2. <https://www.food4rhino.com/app/culebra>
3. <https://www.food4rhino.com/app/sortalgi-shape-grammar-interpreter>

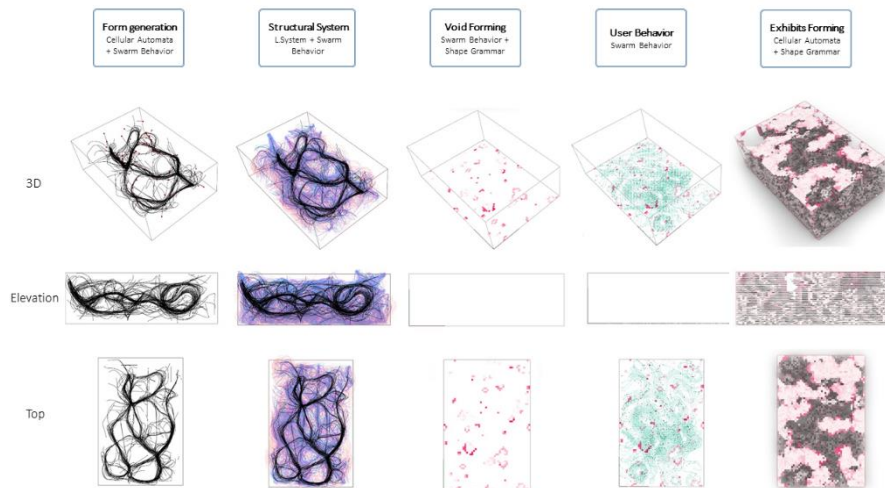

Figure 6. Optimization process results from the methodology.

5. Conclusion

From the previous discussions, all generative systems build on top of one core component, algorithms. In other words, every generative system is an algorithmic system. Any generative system to be applicable to a certain problem, it needed to be customized to provide more specific, and less generic. The downside to this being that the more it is tailored to a specific context, the less useful it may be for others; so, it is not possible to obtain an integrated architectural design resulting from a single generative system, therefore the paper explores and discusses the extent to which integration between these systems can be applied.

This paper reviews the most five GD techniques applied in architectural design to include LS, CA, GA, SG and SI across their system, components, units, control space, grammars, representation and techniques-based characteristics. Based on this review the paper proposes a methodology of an integrated GD systems and discusses the challenges and requirements for developing methodology. The designer viewed as tool developer and central to the design development through an open source system. This interactive expert system can be formed by the designer according to different case studies, (s)he interacts and modify inputs, evaluation criteria, technique selection, building type, plugins used and optimization criteria. Transforming

TOWARDS NEW DESIGN PATTERNS FOR MUSEUM EXHIBITION HALLS USING INTEGRATED ALGORITHMIC GENERATIVE TECHNIQUES

output's technique into another input's technique, is the core of this methodology.

The methodology has been experimented on hypothetical museum exhibition hall to test the feasibility of an integration and identify the conceptual and technical requirements. The experiment provided a simulation of exhibits positions, user behavior and proposing the structural system methodology, this system form the solid and void of the hall through optimization process.

References

- BANTZ, C.R., 1995. Social dimensions of software development. In: J.A. ANDERSON, ed. Annual review of software management and development. Newbury Park, CA: Sage, 502-510.
- BATTY, M. 2005. Cities and Complexity: Understanding Cities with Cellular Automata. Agent-Based Models, and Fractals. Cambridge: The MIT Press. 229-258.
- BONABEAU, E., DORIGO, M., & THERAULAZ, G. 1999. Swarm intelligence: From natural to artificial systems. Oxford University Press.
- BOUFFANAIS, Roland, 2016. Design and Control of Swarm Dynamics. *Springer Briefs in Complexity. First ed. Springer.*
- CHOSMSKY, N. 1985. The Logical Structure of Linguistic Theory. *University of Chicago Press.*
- CICHOCKA J., MIGALSKA A., BROWNE W. & RAMIREZ E., 2017. SILVEREYE – The Implementation of Particle Swarm Optimization Algorithm in a Design Optimization Tool. *Researchgate.net.*
- COATES, P. S., 2004. Review paper: some experiments using agent modelling at CECA. *7th generative art conference.*
- COATES, P. S., & CARRANZA, P. M., 2000. Swarm modelling. The use of swarm intelligence to generate architectural form. *In Generative art.*
- DENEUBOURG, J. L., 1977. Application de l'ordre par fluctuations a la description de certaines etapes de la construction du nid chez les termites. *Insect Soc.* 117-130.
- DING, L., & GERO, J. S., 2001. The emergence of the representation of style in design. *Environment and Planning B: Planning and Design.* 28, 707-731.
- EL KHALDI, M., 2007. Mapping Boundaries of Generative Systems for Design Synthesis. MIT Press.
- GEORGE, S., 2006. Shape. Cambridge: The MIT Press.
- GERO, J. S., & KAZAKOV, V. S., 2001. A genetic engineering approach to genetic algorithms. *Evolutionary Computing.* 71-92
- GRIMM, VOLKER; RAILSBACK, STEVEN, F., 2005. Individual-based Modeling and Ecology. Princeton University Press. 485.
- HANSMEYER, M., 2003. L-System in Architecture. Web. 22 January 2018.

- HOLLAND, J. H., 1975. *Adaptation in natural and artificial systems*. Ann Arbor: University of Michigan Press.
- KNIGHT, T. W., 1998. *Designing a shape grammar*. *Artificial intelligence in design*. The Netherlands: Kluwer Academic Publishers. 499-516.
- KNIGHT, T. W., 1999. *Applications in architectural design, and education and practice*. In Report for NSF/MIT workshop on shape computation, NSF/MIT.
- KRAWCZYK, R., 2002. *Experiments in architectural form generation using cellular automata*. In eCAADe.
- LINDENMAYER, A., 1968. *Mathematical models for cellular interaction in development I. Filaments with one-sided inputs*. *Journal of Theoretical Biology*. 280-289.
- MARTIN, G., 1970. *Mathematical Games - The Fantastic Combinations of John Conway's New Solitaire Game Life*. *Scientific American*. 120-123.
- MITCHELL, M., 1996. *An Introduction to Genetic Algorithms*. Cambridge, MA: MIT Press.
- MINSKY, M., 1967. *Computation: Finite and Infinite Machines*. New Jersey: Prentice-Hall, Inc.
- PAYMAN, A. 2004. *Swarm intelligence*. Pasadena, CA: Jet Propulsion Laboratory.
- PARISH, Y. I. H., & MULLER, P., 2001. *Procedural modeling of cities*. In SIGGRAPH '01: proceedings of the 28th annual conference on computer graphics and interactive techniques. 301e308.
- SALGE, C., LIPSKI, C., MAHLMANN, T., & MATHIAK, B., 2008. *Using genetically optimized artificial intelligence to improve game playing fun for strategic games*. In Proceedings of the 2008 ACM SIGGRAPH symposium on video games. Los Angeles, California: ACM. 7e14.
- SINGH, V., & NING G., 2011. *Towards an integrated generative design framework*. Elsevier Ltd.
- STINY, G., 1980. *Introduction to shape grammars*. *Environment and planning B: Planning and Design*, pp. 343-351.
- THALMANN, D., HERY, C., LIPPMAN, S., ONO, H., REGELOUS, S., & SUTTON, D., 2004. *Crowd and group animation*. In *ACM SIGGRAPH 2004 course notes (p. 34)*. Los Angeles, CA: ACM.
- TERZIDIS, K., 2006. *Algorithmic Architecture*. Architectural Press.
- TEPAVCEVIC, B., STOJAKOVIĆ, V., 2012. *Shape grammar in contemporary architectural theory and design*. *Facta universitatis - series Architecture and Civil Engineering*.
- NEUMANN, N., 1951. *Cerebral mechanisms in behavior-the Hixon symposium*. *New York: John Wiley*. 1-41
- WOLFRAM, S. 2002. *A New Kind of science*. *Wolfram Media Inc*.
- YOON, J. S., & MAHER, M. L., 2005. *A swarm algorithm for wayfinding in dynamic virtual worlds*. In *Proceedings of the ACM symposium on virtual reality software and technology*. 113-116.

DATA-DRIVEN DESIGN OF ADAPTIVE FAÇADES

View, Glare, Daylighting and Energy Efficiency

MAHDI VALITABAR, MOHAMMADJAVAD MAHDAVINEJAD
University of Zanjan, Department of Architecture, Zanjan, Iran
Email address: mahdi.valitabar@gmail.com
Tarbiat Modares University, Tehran, Iran
Email address: mhdavinejad@modares.ac.ir

AND

HENRY SKATES, PEIMAN PILECHIHA
Griffith University, Department of Architecture, Australia
Email address: h.skates@griffith.edu.au
Tarbiat Modares University, Tehran, Iran
Kowsar Institute of Higher Education, Ghazvin, Iran
Email address: p.pilechiha@modares.ac.ir

Abstract. This paper attempts to increase occupants' view to outside through Adaptive facades by employing a parametric design method. Reaching a balance between occupants' requirements and the building energy criteria is the main objective of this research. To this end, a multi-objective optimization is done to generate some optimum models. The method, indeed, was used to optimize the shading size of a dynamic vertical shading system utilized on the south façade of a single office room located in Tehran. The shading system was defined by five parameters and a combination of Cut-off and a glare protection strategy is used to control dynamic shadings. The size-optimisation objectives are minimum DGP, cooling load and maximum illuminance, which were analysed by Ladybug Tools. Then, Octopus was used for multi-objective optimisation to find new optimum forms. Along with the openness factor, a new index is presented to evaluate the outside view in multiple louver shading systems, named "Openness Curvature Factor" (OCF). Thanks to this method, the size and shape of some optimum generated models were modified to increase the amount of OCF. Following that the Honeybee Plus is used to simulate the visual performance of modified models which shows a significant improvement. The modified models could provide about 4 times more outside view than generated models whilst keeping the DGP value in

imperceptible range. Geometric or even complex non-geometric shading forms can be studied by this method to find optimum adaptive facades.

Keywords: Adaptive solar façade; Multi-objective optimization; Openness Factor; View; Visual comfort; Energy performance; Parametric design;

ملخص. تحاول هذه الورقة زيادة رؤية الركاب للخارج من خلال واجهات تكيفية من خلال تقديم طريقة تصميم حدودي. الهدف الرئيسي لهذا البحث هو تحقيق التوازن بين متطلبات شاغلي المبنى ومعايير طاقة المبنى. تحقيقاً لهذه الغاية، يتم إجراء تحسين متعدد الأهداف لإنشاء بعض النماذج المثلى. تم استخدام هذه الطريقة بالفعل لتحسين حجم التظليل لنظام التظليل الرأسي الديناميكي المستخدم على الواجهة الجنوبية لغرفة مكتب واحدة تقع في طهران. تم تحديد نظام التظليل من خلال خمسة معلمات ويتم استخدام مزيج من إستراتيجية القطع وإستراتيجية الحماية من الوهج للتحكم في التظليل الديناميكي. أهداف تحسين الحجم هي الحد الأدنى من DGP وحمل التبريد والحد الأقصى من الإضاءة، والتي تم تحليلها باستخدام أدوات Ladybug. بعد ذلك، تم استخدام Octopus للتفاوض متعدد الأهداف لإيجاد أشكال جديدة مثالية. إلى جانب عامل الانفتاح، يتم تقديم فهرس جديد لتقييم المنظر الخارجي في أنظمة تظليل متعددة الفتحات، يُسمى "عامل انحناء الانفتاح (OCF)" بفضل هذه الطريقة، تم تعديل حجم وشكل بعض النماذج المُولدة المثلى لزيادة كمية OCF بعد ذلك يتم استخدام Honeybee Plus لمحاكاة الأداء المرئي للنماذج المعدلة مما يظهر تحسناً كبيراً. يمكن أن توفر النماذج المعدلة حوالي 4 مرات منظر خارجي أكثر من النماذج التي تم إنشاؤها مع الحفاظ على قيمة DGP في نطاق غير محسوس. يمكن دراسة أشكال التظليل الهندسية أو حتى المعقدة غير الهندسية بهذه الطريقة للعثور على واجهات تكيفية مثالية.

الكلمات المفتاحية: واجهة شمسية تكيفية. متعدد الأهداف التحسين. عامل الانفتاح رأسي؛ الراحة البصرية أداء الطاقة؛ تصميم حدودي

1. Introduction

Building facades play a leading role in improving building energy efficiency while aesthetically, it is the public face of a building. Therefore, it significantly affects people's perception of a building (Nagy et al., 2016). Some of the paradoxical design parameters of facades are daylight versus glare, views versus privacy and fresh air versus draught risk (Adriaenssens et al., 2014; Pilechiha et al., 2020). Energy saving in a building without windows is greater than one with windows, but generally it is not recommended. This is because natural light has a key role to play in visual comfort and has a biological effect on occupants (Hee et al., 2015). To reach the admissible levels of functionality, façades can be changed or adapted to suit requirements. Therefore, the utilisation of adaptive facades provides opportunities for reducing building's energy demands, while preserving the thermal and visual comfort for occupants (Aelenei et al., 2016). Exterior shading devices control the transmission of daylight and reduce solar heat

DATA-DRIVEN DESIGN OF ADAPTIVE FACADES: VIEW, GLARE, DAYLIGHTING AND ENERGY EFFICIENCY

gain (Vera et al., 2016). The use of internal blinds decreases direct radiation to the interior, but increases the solar heat gain coefficient, and may increase the energy needed for cooling. Additionally, the reduction in daylighting increases the reliance on artificial lighting (Fasi and Budaiwi, 2015). Kinetic facades, which have high-performance glazing and shading systems, when merged with lighting and thermal system controls can possibly adjust daylighting requirements and comfort (Xiong and Tzempelikos, 2016). Consequently, an effective control strategy along with optimum shading geometries are needed to meet occupant's requirements while reducing operational energy.

View quality depends on the outside landscape whilst view clarity can be quantified by visual conditions and fenestration characteristics. The elements of connection to outdoor which can be quantified are (i) the amount of view outside, in terms of the relative size of openings compared to opaque walls, and (ii) the view clarity through windows. The clarity of view through actual windows or glass facades depends on the layering of fenestration systems (glazing and shading system) and their optical properties (Konstantzos et al., 2015). When both daylight and solar gain are taken into consideration holistically, then kinetic skins and shading devices play a key role in controlling indoor environments (Ahmed Mahmoud and Elghazi, 2016; Nadiri et al., 2019). Architectural designing is, of course, a process in which designers seek the best solution based on a wide variety of parameters. Designers seek to achieve a balance between occupants' comfort and building energy criteria, however, human judgment and experience are often insufficient in deriving the best solutions (Zhang et al., 2016). To this end, the usage of parametric design approach at the early design stage is needed. This article uses daylight glare probability index (DGP) to evaluate Glare and Means illuminance index for daylight. The DGP index (Imperceptible<0.35-Perceptible (0.35-0.40) - Disturbing (0.40-0.45) - Intolerable>0.45) was first proposed in 2006 (Wienold and Christoffersen, 2006). The desirable domain for daylight illuminance (perpendicular to the eye of the occupant) is in the range of 300 Lux to around 3,000 Lux (Mardaljevic et al., 2012), however, illuminance less than 2,000 Lux was reported as being in the visual comfort range and more than 3,000 Lux as creating visual discomfort (Bian and Luo, 2017).

It is noticeable that the behaviour of adaptive solar facades (ASF) in summer is quite logical. The shading devices are located in front of incident radiation to control the inside temperature and protect the occupants from the risk of glare. However, in winter the situation is different; the inner space needs to gain more solar radiation to provide occupant thermal comfort. Due to this seasonal difference, the shadings ideally should not cover the

transparent surface of buildings in winter. Moreover, because of the sun's relatively low position in winter, the problem of glare is exacerbated. The best solution to this problem would be an ASF that can simultaneously achieve both visual and thermal comfort goals throughout the year. This can be accomplished by using parametric design approach. Despite considerable devoted researches in this field, some questions have not been properly answered yet. For instance, as can be seen in Figure 1, in some built projects the dynamic vertical shadings were utilized on south façades. This paper intends to investigate the performance of dynamic three-layer vertical shading systems mounted on south façade of an office building by considering these objectives: 1) increasing view quantity 2) increasing natural light penetration 3) decreasing the risk of glare 4) declining cooling load. The main research questions come as follows:

1. Could ASF afford occupants this great opportunity to have an outside view without glare throughout the entire year?
2. In terms of occupants' visual comfort and operational energy, is it acceptable to use dynamic vertical shadings on south façades?

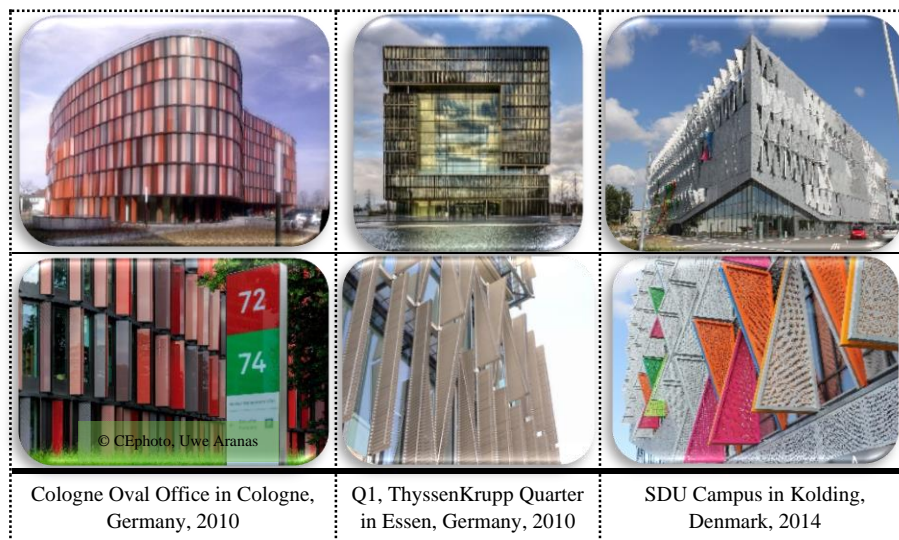

Figure 1. South façade and vertical dynamic shadings (Wikimedia, 2021).

2. Methodology

It has become, recently, common to use data-driven methods in Architectural design with the objective of integrating different performance criteria including operational energy, daylighting and window view. Indeed, the term “big data” is now considered as the core of many Architectural design process. In this research, the parametric model was designed in

DATA-DRIVEN DESIGN OF ADAPTIVE FACADES: VIEW, GLARE,
DAYLIGHTING AND ENERGY EFFICIENCY

Grasshopper and Ladybug Tools was used to simulate both visual comfort and energy consumption. Ladybug Tools uses EnergyPlus engine for energy simulation. It also uses Daysim and Radiance for daylighting simulation. The model is an office room with 4.0 m × 5.0 m area and 2.8 m height. The dynamic vertical shading was mounted on south façade and includes a 2.52 m to 3.60 meters window. Figure 2 illustrates the research parameters. The shading system used in the parametric model, was first presented in a previous paper and includes 11 louvers in front of the south façade which cover the window (Valitabar et al., 2018). A combination of Cut-off and glare protection strategies were utilized to reach a balance between occupants' requirements and building energy criteria. The materials' properties are considered as fixed parameters.

Research Parameters						
Site Location			Design Objectives			
Tehran, Iran			a. Maximizing natural light			
Function & Space Area			b. Decreasing Daylight Glare			
Single Office Room – 20 m ²			Probability			
			c. Saving Cooling Load			
Model Fixed Parameters			Materials		Reflectance	UValue_SI
	Ceiling	1/2IN	AtticFloor NonRes	1/2IN Gypsum	70%	0.292
		Gypsum	Insulation-3.67			(W/m ² K)
	Wall	1IN Stucco	8IN CONCRETE	1/2IN Gypsum	50%	3.690
			HW RefBldg			(W/m ² K)
	Floor	1/1IN	AtticFloor NonRes	1/2IN Gypsum	30%	0.291
		Gypsum	Insulation-3.67			(W/m ² K)
Glazing		Ratio: 81%; Simple Glazing System; SHGC= 0.25 %; U-value= 3.24 W/m ² K				
		Solar reflectance	Transmittance	emittance	Thickness	Conductivity
Shading		0.65 (%)	0 (%)	0.9 (%)	0.25 (mm)	221 (W/m ² k)
Time	Month: March- June- September- December * Day: 21 * Hour: 10, 11, 12, 13, 14, 15, 16					

Figure 2. Research parameters

The values of DGP, mean illuminance and energy consumption were calculated hourly between 10:00 a.m. to 4:00 p.m. in 21th of March, June, September and December. Indeed the generated models were analysed for 28 hours. The control strategy, firstly, try to block direct sun radiations by changing the slat angles and then protect occupants against the risk of glare

by changing the gaps between three slats to reach optimum forms. The optimization process took about 40 hours. The analysis was done by a laptop with 16GB RAM and Intel (R) Core (TM) i7-4710 HQ CPU 2.50 GHz and NVIDIA GEFORCE GTX 860M.

The highest amount of glare phenomenon is when looking directly at a window in a standing position (Park et al., 2003). In a field study that was conducted to find a relationship between useful daylight illuminance and daylight glare probability in a residential building, the eye height is used for measuring the vertical illuminance (Mardaljevic et al., 2012a, b). In another study, the camera used for HDR creation, was in the centre of the space at the eye height level (Xiong and Tzempelikos, 2016a, b). In the base-model of the MIT office space, 297 analysis sensor points were located at 0.9 m above the ground in the working plane (Wagdy et al., 2016). In this paper, the seated position looking directly at the window (with 1.40 m distance from the window) was selected to analyse visual comfort since this is the normal case in an office.

In this paper, Hype reduction algorithm was taken as the multi-objective algorithm similar to (Pilechiha et al., 2020). "Multi-objective optimization aims to find good values for more than one performance objective. Often, there is a trade-off between objectives: e.g. allowing more daylight into a room can lead to more glare." (Wortmann, 2017). Finding novel optimum ASF based on louver size is the aim and objective of this paper. Visible transmittance and shadings materials are used as the fixed factors and openness factor (OF) as the variable factor. The properties of the base model are illustrated in Figure 3.

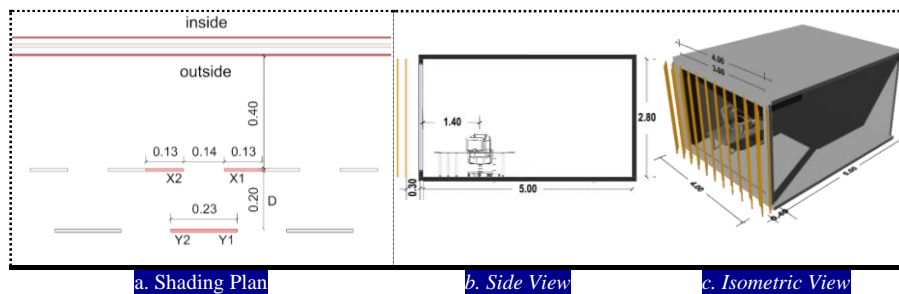

Figure 3. The properties of the base model

3. Openness Curvature Factor (OCF)

In the literature review, there are some metrics to evaluate outdoor view including LEED Quality Views. Regarding the LEED standard, in 75% of occupied area occupants must have a direct view to outside to get 1 point

DATA-DRIVEN DESIGN OF ADAPTIVE FACADES: VIEW, GLARE,
DAYLIGHTING AND ENERGY EFFICIENCY

(LEED v4, 2013). LEED Quality Views considers both view quality and quantity. Furthermore, OF is the percentage of “open” or “see-through” the shading fabric (ASHRAE, 2013). Since the entire indoor area must be taken into account to calculate the aforementioned metrics, they could be considered as the surface-centred metrics. The focus of this paper is on the amount of view quantity through multi-layer shadings at a specific user position leading to present OCF as a point-centred metric. As can be seen in Figure 4, an acceptable amount of OCF could provide outside view while the value of OF might equal zero. The OCF was developed based on OF and calculated through the following method and formula:

The occupant’s eyes are linked with two lines to the edge of louvers and a semicircle with center at user’s eyes was drawn, which is shown with black color. The largest length of arc within the user field of view wherein user could see outside view through one of the multiple louvers, was calculated as the T_{arc} . Then V_{arc} as the length of black semicircle which is intersected with the hatched area in blue color is calculated. Finally, OCF is defined as the percentage of openness in a semicircle within the occupant field of view that centered at the user’s eyes.

$$V_{arc} = \frac{(\beta_1 + \beta_2)}{360} * 2\pi r \quad (1)$$

$$T_{arc} = \frac{\alpha}{360} * 2\pi r \quad (2)$$

$$OCF = V_{arc} / T_{arc} \quad (3)$$

Furthermore, the openness factor is defined as the ratio of unobstructed view through slats to outdoor to the whole area of slats. In this paper we firstly, remove the D parameter as illustrated in Figure 4.

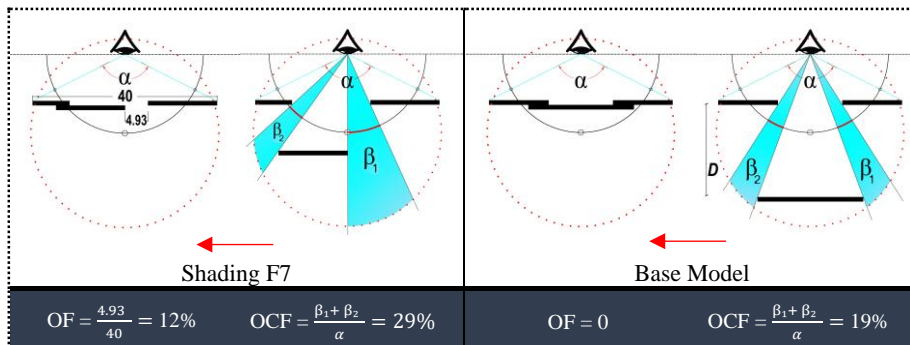

Figure 4. A comparison between OF and OCF

Indeed, the front slat is aligned with the two back slats. Secondly, the open area between slats based on a vertical plane is calculated and then divided into the whole area of slates. Consequently, it is needed to use OCF to evaluate the amount of view through shadings gaps in multi-layer shading systems.

4. Optimization Results

Figure 5 is a 3D chart of all paper objectives which shows all models generated by optimization tool in a 3D format. The dispersion of the models based on glare, cooling energy and illuminance were shown separately and in general. As can be seen from the figure, the trend of all objectives was downward. The domain of models with at least glare and energy was selected. Then, among the models in this threshold, the optimum ones based on illuminance were chosen. The results of objectives for models generated in the early stage of the optimization process, are far from the desirable range. The models with values less than 0.4 for DGP were considered as the desirable domain. There is a centralization of models in a domain which is between 1500 and 3000 Lux for illuminance, 670 and 675 (Kwh/m²) for cooling load. Based on the project's requirements, designers could choose their shadings from in this optimum model's domain.

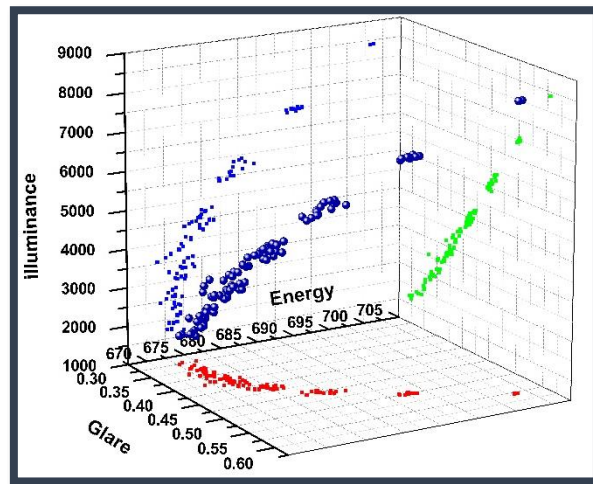

Figure 5. 3D chart of Generated Models

Table 1 shows the results of the objectives for some of the generated models by Octopus. As it is obvious from Table 1, the values of DGP for optimum models are under 40 percent. Especially, models F1, F2, F3 and F4 are in imperceptible range. Besides, optimum models could slash the cooling load compared to the worst models.

DATA-DRIVEN DESIGN OF ADAPTIVE FACADES: VIEW, GLARE, DAYLIGHTING AND ENERGY EFFICIENCY

TABLE 1. The simulation results for some models.

Shadings	Objectives			Parameters*							
	Total Cooling load	Total illuminance	Total Glare (DGP)	X1	X2	D	Y1	Y2	OF	OCF	
	(Kwh/m ²)	(Lux)	(%)	(cm)	(cm)	(cm)	(cm)	(cm)	(%)	(%)	
Optimum Models	F1	673.4	1733	0.32	15	8	10	15	15	0	10
	F2	675.1	1657	0.32	8	15	0	15	15	0	0
	F3	672.9	1744	0.33	8	15	10	15	15	0	9
	F4	674.1	1906	0.34	8	8	10	15	15	0	19
	F5	674.5	2104	0.35	8	0	0	15	15	12.5	6
	F6	674.6	2325	0.35	15	15	0	8	0	13	20
	F7	674.8	2554	0.37	15	8	10	0	15	12	29
	F8	675.2	3000	0.38	0	0	10	15	15	25	44
Worst Models	i	690.1	6915.5	0.52	0	0	0	0	8	77.5	69
	ii	682.0	5849.1	0.48	8	8	0	0	0	60	75

*For more details about the parameters, readers refer to Figure 3.

Furthermore, the value of OCF varies from zero to 44%. Model F2 like a single solid shading system has zero value of OF and OCF, while, model F8 gives us a high value of openness. The model F4 has zero OF value, while, it is 12.5% for model F5. Contrary, the value of OCF for model F4 is three times more than model F5. As it is illustrated in Figure 6, in a comparison between model F3 and F7, it is concluded that the OCF is a more reliable indicator to evaluate outside view in shadings comprise of multiple layers. According to Figure 6, some of the optimum models even in extreme time hours (fully closed) can provide view connection to outside. It seems that shading F8 can provide more view than others to outside. However, it should not be ignored that the high amount of OF might cause discomfort glare from direct sun radiations. In this regard, a combination of both OF and OCF should be taken into account to select the optimum model. As a result, model F4 with zero OF and 19% of OCF might be considered as the desirable model. This method is presented to evaluate the view through multiple-layer shadings.

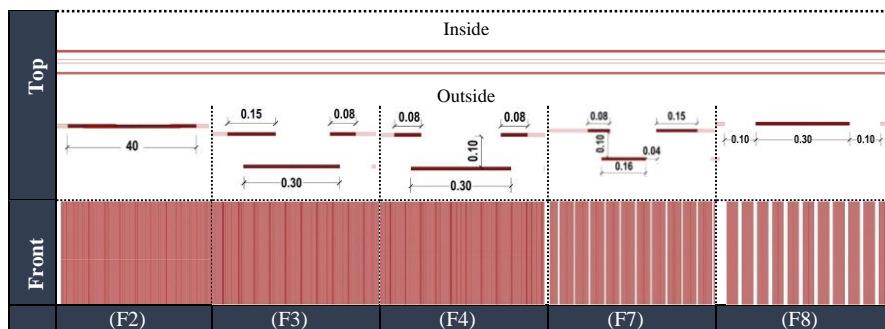

Figure 6. The optimum shadings form and their dimensions

5. Models Modification

The ultimate outcome of this research is illustrated in Figure 7, in which the OCF values of two optimum models are clearly demonstrated. Firstly, among generated models the ones with three elements and zero OF were selected. This is because having an outside view is impossible if the gaps between louvers are eliminated. Therefore, the only indicator is remained to analyze outside view in these multiple (solid) louvers is OCF. Without changing the OF, then, the form and size of slats were modified in order to provide more outside view. As it was expected, the value of OCF for all models increased specially for model F3 by four times. This stage ought to be done through a parametric optimization to reach optimum results with novel shapes.

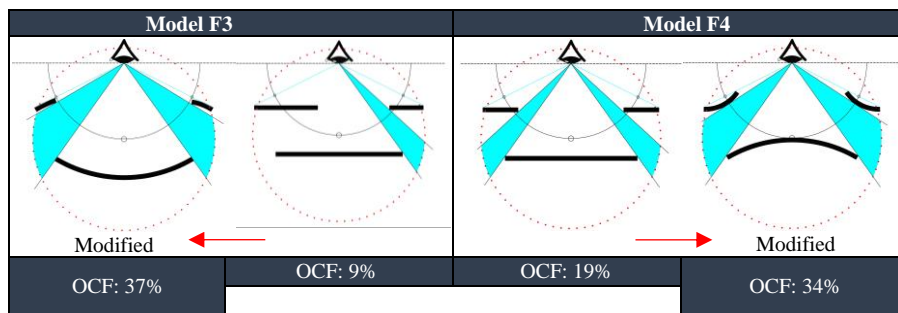

Figure 7. The modified models

Furthermore, Honeybee Plus [+] was used to analyse the DGP value of modified shading F3 on the 21st of December at 12 A.M. for two view direction, 45 degree and direct toward outdoor. Figure 8 shows the results of simulation and form of modified shading F3. As can be seen in Figure 8, the DGP value for both view at that extreme time is in imperceptible range while the worst model as illustrated in Table 2 might experience intolerable DGP. Moreover, the amount of outdoor view that occupants could have through this shading at the mentioned time is great. The occupants view toward outdoor is significantly satisfactory compared to common shading systems such as venetian blinds and roller shades which usually block the outside view at extreme time hours.

DATA-DRIVEN DESIGN OF ADAPTIVE FACADES: VIEW, GLARE, DAYLIGHTING AND ENERGY EFFICIENCY

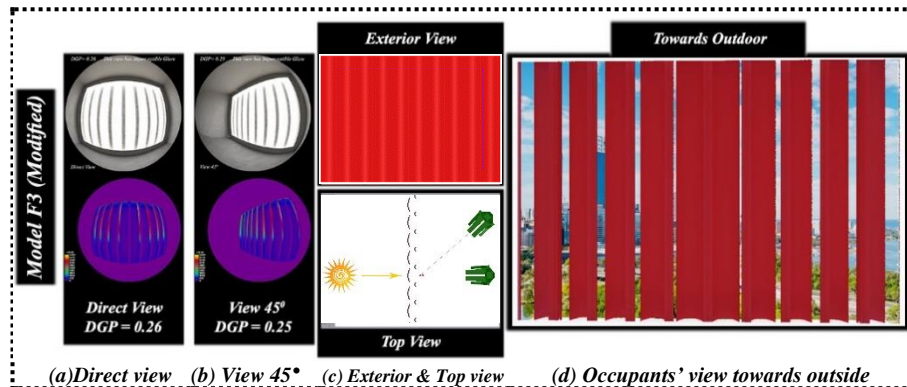

Figure 8. Honeybee Plus[+] simulation for modified shading F3

6. Conclusions

The primary aim of this paper was presenting a method whereby Architects could design optimum adaptive solar facades concerning the view, visual comfort and operational energy. The results of this research demonstrate that the optimum models generated by enhancing the dimensions of the slats can reach a balance between occupant's requirements and building energy criteria. Not only can this method be used to find optimum ASF with different geometry, but also on given the models with different room geometries, there would be different results. Future research should be conducted by using different geometries and shading materials for the whole year in different climates in order to come to more accurate results. A summary of the research findings come as follows:

1. The developed metric based on openness factor enables Architects to evaluate view quantity of multi-layer shading systems.
2. The usage of dynamic vertical shadings on south facades not only could provide occupants comfort and slash operational energy but they also significantly improve the outdoor view.
3. Architects could utilize this parametric method to design high performance ASF which offer an acceptable outdoor view for the whole year compared to common shadings including venetian blinds and roller shades.
4. This parametric design approach could be used to generate some optimum shading systems which improve outside view about 4 times while maintaining DGP value in imperceptible range.
5. Generating some novel shapes of ASF through a form-finding process by applying this method to Geometric shapes and complex non-geometric shapes is feasible.

References

1. Adriaenssens S, Rhode-Barbarigos L, Kilian A, Baverel O, Charpentier V, Horner M, Buzatu D. (2014), "Dialectic form finding of passive and active shading enclosures", *Energies*, Vol. 7(8), pp.5201-5220. <https://doi.org/10.3390/en7085201>.
2. Aelenei D, Aelenei L, Vieira CP. (2016), "Adaptive façade: concept, application, research questions", in *Proceedings of the 4th International Conference on Solar Heating and Cooling for Building and Industry (SHC 2015)*, Vol. 91, pp.269-275. <https://doi.org/10.1016/j.egypro.2016.06.218>.
3. ASHRAE. *ASHRAE Handbook-fundamentals*. (2017), "Chapter 15: fenestration", Atlanta, USA: American Society of Heating, Refrigeration and Air-Conditioning Engineers.
4. Ahmed Mahmoud, A. and Elghazi, Y. (2016), "Parametric- based design for kinetic facades to optimize daylight performance: comparing rotation and translation kinetic motion for hexagonal façade patterns", *Solar Energy*, Vol. 126, pp. 111-127. <https://doi.org/10.1016/j.solener.2015.12.039>.
5. Bian, Y. and Luo, T. (2017), "Investigation of visual comfort metrics from subjective responses in china: a study in offices with daylight", *Building and Environment*, Vol. 123, pp. 661-671. <https://doi.org/10.1016/j.buildenv.2017.07.035>.
6. Cologne Oval Office. (2010), Wikimedia, available at: https://commons.wikimedia.org/wiki/File:Cologne_Oval_Offices_02.jpg
https://commons.wikimedia.org/wiki/File:Cologne_Germany_Cologne-Oval-Offices-03.jpg (accessed: 26 January 2021)
7. Doe, R. and Aitchison, M. (2015), "Multi- criteria Optimization in the Design of Modular Homes, From Theory to Practice", *Proceeding of eCAADe Conference 33*, pp. 295- 304.
8. Fasi, M.A. and budaiwiw, I.M. (2015), "Energy performance of windows in office building considering daylight integration and visual comfort in hot climates", *Energy and Building*, Vol. 108, pp. 307-316. <https://doi.org/10.1016/j.enbuild.2015.09.024>.
9. Hee, W., Alghoul, M., Bakhtyar, B., Elayeb, O., Shameri, M., Alrubaih, M., & Sopian, K. (2015), "The role of window glazing on daylighting and energy saving in buildings", *Renewable and Sustainable Energy Reviews*, Vol. 42, pp. 323-343. <https://doi.org/10.1016/j.rser.2014.09.020>.
10. Jakubiec, A. and Reinhart, C. (2010), "The use of Glare Metrics in Design of Daylit Space; Recommendation for Practice", Paper presented at the 9th international Radiance Workshop.
11. Konstantzos, I., Chan, C., Seibold J., Tzempelikos, A., W. Proctor, R., & Protzman, J. (2015), "View clarity index: A new metric to evaluate clarity of view through window shades", *Building and Environment*, Vol. 90, pp. 206- 214. DOI: 10.1016/j.buildenv.2015.04.005.
12. USGBC, United States Green Building Council (USGBC), *LEED v4 for Building Design and Construction*, Washington, D.C., USA, 2018. <https://www.usgbc.org/credits/new-construction-commercial-interiors-schools-new-construction-retail-new-construction-ret-2> , (accessed: 27 January 2021)
13. Mardaljevic, J., Anderson, M., Roy, N., & Christoffersen, J. (2012), "Daylighting metrics: is there a relation between useful daylight illuminance and daylight glare probability?", in *Building Simulation and Optimization Conference, IBPSA 2012*, England, Loughborough, UK.
14. Nagy, Z., Svetozarevic, B., Jayathissa, P., Begle, M., Hofer, J., Lydon, G., & Schlueter A. (2016), "The Adaptive Solar Façade; from concept to prototypes", *Frontiers of Architectural Research*, Vol. 5 No. 2, pp. 143-156. <https://doi.org/10.1016/j.foar.2016.03.002>.

DATA-DRIVEN DESIGN OF ADAPTIVE FACADES: VIEW, GLARE,
DAYLIGHTING AND ENERGY EFFICIENCY

15. Nadiri, P., Mahdavinejad, M., & Pilechiha, P. (2019), "Optimization of Building Façade to Control Daylight Excessiveness and View to Outside", *Journal of Applied Engineering Sciences*, Vol. 9 No 2, pp. 161-168. <https://doi.org/10.2478/jaes-2019-0022>.
16. Park, CS., Augenbroe, G., Messadi, T. (2003), "Daylighting optimization in smart façade systems", *Proceedings of the Eighth International IBPSA Conference*.
17. Pilechiha, P., Mahdavinejad, M., & Beizae, A. (2020), "Simulation Assisted Design Exploration to Evaluate View and Energy Performance of Window Shading", in Howard, B., Oraiopoulos, A., & Brembilla, E, 5th IBPSA-England Conference on Building Simulation and Optimization, IBPSA-England.
18. Pilechiha, P., Mahdavinejad, M., Rahimian, F. P., Carnemolla, P., & Seyedzadeh, S. (2020), "Multi-objective optimisation framework for designing office windows: quality of view, daylight and energy efficiency", *Applied Energy*, Vol. 261, 114356. <https://doi.org/10.1016/j.apenergy.2019.114356>.
19. SDU Campus in Kolding. (2014), Wikimedia, available at: [https://commons.wikimedia.org/wiki/File:Syddansk_universitet.Campus_Kolding.Denmark.2014_\(37\).JPG](https://commons.wikimedia.org/wiki/File:Syddansk_universitet.Campus_Kolding.Denmark.2014_(37).JPG)
[https://commons.wikimedia.org/wiki/File:Syddansk_universitet.Campus_Kolding.Denmark.2014_\(46\).JPG](https://commons.wikimedia.org/wiki/File:Syddansk_universitet.Campus_Kolding.Denmark.2014_(46).JPG) (accessed: 26 January 2021)
20. ThyssenKrupp Quarter. (2010), Wikimedia, available at: <https://commons.wikimedia.org/wiki/File:Thyssen-Krupp-Quartier-Essen-Q1-2013.jpg>
https://commons.wikimedia.org/wiki/File:ThyssenKrupp_Quartier_Essen_07.jpg (accessed: 26 January 2021)
21. Vera, S., Uribe, D., Bustamante, W., & Molina, G. (2016), "Optimization of a fixed exterior complex fenestration system considering visual comfort and energy performance criteria", *Building and Environment*, Vol. 113, pp. 163-174. <https://doi.org/10.1016/j.buildenv.2016.07.027>.
22. Valitabar, M., Moghimi, M., Mahdavinejad, M., Pilechiha, P. (2018), "Design optimum Responsive Façade Based on Visual Comfort and Energy Performance", in: Fukuda, T., Huang, W., Janssen, P., Crolla, K., & Alhadidi, S. (Ed.), 23rd International Conference on Computer-Aided Architectural Design Research in Asia: Learning, Prototyping and Adapting, CAADRIA 2, The Association for Computer-Aided Architectural Design Research in Asia (CAADRIA), Beijing, China, Tsinghua University, 2018, pp. 93-102.
23. Wagdy, A., Fathy, F., & Altomonte, S. (2016), "Evaluating the daylight performance of dynamic façade by using new annual climate- based metrics", in 36th International Conference on Passive and Low Energy Architecture. *Cities, Buildings, People: Towards Regenerative Environment*, PLEA 2016, Los Angeles, California, USA.
24. Wienold, J., Christoffersen, J. (2006), "Evaluation methods and development of a new glare prediction model for daylight environments with the use of CCD cameras", *Energy and Buildings*, Vol. 38 No. 7, pp. 743-757. <https://doi.org/10.1016/j.enbuild.2006.03.017>.
25. Wortmann, T. (2017), "Opossum: Introducing and Evaluating a Model- based Optimization Tool for Grasshopper", in: Janssen, P., Loh, P., Raonic, A., & Schnabel, M.A. (Ed.), 22nd International Conference on Computer-Aided Architectural Design Research in Asia: Protocols, flows and Glitches, The Association for Computer-Aided Architectural Design Research in Asia (CAADRIA), XI'AN Jiaotong-Liverpool University, Suzhou, China.
26. Xiong, J., Tzempelikos, A. (2016), "Model- based shading and lighting controls considering visual comfort and energy use", *Solar Energy*, Vol. 134, pp. 416-428. <https://doi.org/10.1016/j.solener.2016.04.026>.
27. Zhang, L., Zhang, L., & Wang, Y. (2016), "Shape optimization of free- form building based on solar radiation gain and space efficiency using a multi- objective genetic algorithm in the severe cold zones of china", *Solar Energy*, Vol. 132, pp. 38- 50. <https://doi.org/10.1016/j.solener.2016.02.053>.

D2.P2.S3

TECHNOLOGY INTEGRATION AND COLLABORATION III

DEVELOPING A DESIGN FRAMEWORK FOR THE 3D PRINTING PRODUCTION OF CONCRETE BUILDING COMPONENTS

A case study on column optimisation for efficient housing solutions in Saudi Arabia

MOHAMMAD ALABBASI, HAN-MEI CHEN

University of Liverpool

Email address: m.alabassi@liverpool.ac.uk

Email address: hanmei.chen@liverpool.ac.uk

AND

ASTERIOS AGKATHIDIS

Email address: asterios.agkathidis@liverpool.ac.uk

Abstract. This paper is examining the development of a design and fabrication framework aiming to increase the efficiency of the construction of concrete building components by introducing 3D concrete printing in the context of Saudi Arabia. In particular, we will present an algorithmic process focusing on the design and fabrication of a typical, mass customised, single-family house, which incorporates parametric modelling, topology optimisation, finite element (FE) analysis and robotic 3D printing techniques. We will test and verify our framework by designing and fabricating a loadbearing concrete column with structural and material properties defined by the Saudi Building Code of Construction. Our findings are highlighting the advantages and challenges of the proposed file-to-factory framework in comparison to the conventional construction methods currently applied in Saudi Arabia, or other similar sociopolitical contexts. By comparing the material usage in both conventional and optimised columns, the results have shown that material consumption has been reduced by 25%, the required labour in the construction site has been mitigated by 28 and the duration time has been reduced by 80% without the need for formwork.

Keywords: *Building Technologies; Additive Manufacturing of Concrete; Housing Construction; 3D Printing; Topology Optimisation; Parametric Design.*

ملخص. تهدف الدراسة إلى تطوير منهجية لأتمتة عملية التصميم والتصنيع بهدف زيادة كفاءة البناء الخرساني باستخدام الطباعة الخرسانية ثلاثية الأبعاد في سياق منظومة صناعة البناء في المملكة العربية السعودية، تم تطوير خوارزمية تركز على تصميم وتصنيع الهيكل الإنشائي لفيلا سكنية، يمكن للمستفيد تعديل التصميم بشكل آلي حسب رغبته وعرض النموذج بشكل

ثلاثي الأبعاد، تعتمد هذه الخوارزمية على نظام النمذجة البارامترية، وتحسين الهيكل الإنشائي، مما يمكن تهيئة العنصر المحسن لعملية الطباعة الخرسانية باستخدام ذراع آلي. تسلط النتائج التي توصلنا إليها الضوء على مزايا وتحديات أتمتة التصميم والتصنيع و مقارنتها بأساليب البناء التقليدية المطبقة حاليًا في سوق البناء السعودي، من خلال مقارنة كمية استخدام المواد وعدد العمال والمدة المستغرقة من التصميم إلى التنفيذ، تم التركيز على الأعمدة الخرسانية المسلحة لإجراء المقارنة، واستخدام تقنية تحسين الطبوغرافية بما يتلاءم مع الطباعة الثلاثية الأبعاد، حيث أظهرت النتائج أنه تم تقليل استهلاك المواد بنسبة 25%، وتم تخفيف العمالة المطلوبة في موقع البناء بمقدار 28% وتم تقليل المدة الزمنية بنسبة 80% مع الأخذ في الاعتبار عدم الحاجة إلى استخدام قوالب خشبية لصب الخرسانة.

الكلمات المفتاحية: تقنيات البناء، المباني المطبوعة، أتمتة التصميم، الإسكان، أتمتة البناء.

1. Introduction

The typical construction method used for housing construction in Saudi Arabia in current days is the in-situ fabrication of reinforced concrete. This method has shown many inefficiencies for such as high labour force demand, lack of construction quality and high time demand (Theodore Karasik, 2017). Moreover, prefabrication in the housing construction industry is uncommon due to the high cost and lack of customisation. The average Saudi homeowners prefer to live in a house designed for their particular needs, rather than to live in a standardised house (Alqahtany and Mohanna 2019; and Alhubashi 2018).

In 2016, the ministry of housing had announced a new delivery plan, which targets building half a million residential units to increase housing ownership (Saudi Ministry of Housing, 2016). As the main factors behind housing shortage are construction delays and lack of labour force (Alhajri and Alshibani, 2018), the Ministry of Housing in Saudi Arabia has sought to establish an initiative to support novel construction technologies and made contracts, as part of its contribution to the National Transformation Plan 2030. The targets of these contracts are to raise the ownership rate from 24% to 52% (Government of Saudi Arabia, 2016).

Having identified the main challenges and reviewed the requirements of the Saudi Concrete Building Structures (SBC 304), the proposed design-to-fabrication framework will adopt its requirements and specifications for the production of 3D printed reinforced concrete components. Accordingly, we will develop a parametric reinforced-concrete frame structure of a typical Saudi Villa. One of the columns will be optimised and analysed under an axial load of 31kN/m². As mentioned in SBC 304, the concrete's compressive strength should not be less than 20 MPa (SBC Committee 304, 2007). Therefore, we chose to use C40 concrete in the optimisation process.

This research examines how robotic technologies and additive manufacturing techniques can be implemented in the current construction setting of Saudi Arabia in order to optimise the production of housing

DEVELOPING A DESIGN FRAMEWORK FOR THE 3D PRINTING PRODUCTION OF CONCRETE BUILDING COMPONENTS

construction components. Our research aims to improve construction cost-efficiency by decreasing material consumption and cost of labour as well as increasing the productivity and construction quality. Our research objectives include eliminating the waste of formwork materials, reducing labour intensity, and reducing the construction time by using robotic technology. In particular, we will investigate the application of robotics in construction in order to increase construction efficiency and reduce construction time, thus reduce construction cost. Consequently, our research questions are as follows:

- How can we develop a design and fabrication framework for a typical single-family house in Saudi Arabia?
- How can the use of robotic technologies increase construction efficiency in Saudi Arabia?
- How can the reinforced-concrete frame structure of such a house be optimised and prepared for 3D printing?

The above questions will be answered in three phases: a) developing a design to fabrication framework for a typical single-family house; b) using this framework to design, optimise and analyse of 3D printed load-bearing concrete column; c) verifying its efficiency, by simulating the fabrication process of the column and compare it with a conventional fabrication process.

2. Background and Literature Review

2.1. ADDITIVE MANUFACTURING IN CONSTRUCTION

Additive manufacturing (AM) of concrete technologies, well known as cement-based 3D printing, has been developing rapidly in the past decade and are continuously proving their potential to rationalise the construction industry. AM of concrete can produce high accuracy building components in cost and high time-efficiency (Mechtcherine et al., 2019). The amount of required labour can be reduced accordingly. Most of the AM applications in the construction industry implement an extrusion-based material technique to create concrete layers, based on sliced CAD geometry (Buswell et al., 2018). This approach enables more flexibility to construct complex geometries without requiring a mould to cast concrete (Comminal et al., 2020).

The application for AM of concrete can be performed either in-situ or as a prefabricated component. A common technique of in-situ 3D printing concrete in-situ focuses on the fabrication of building walls as performed in the BOD building by COBOD in Denmark; Studio 2030 by CyBe in Saudi Arabia; and Dubai municipality building by ApisCore in UAE. These precedents are just indicators of the existing possibilities. However, there is a

clear gap between buildings regulations and AM technologies, which required an approach to link these two sides.

The applications of AM in construction demonstrated advantages over conventional construction method. One such advantage is the reduction of construction time and cost. Other significant advantages are the increase in the health and safety standards of the construction workers as well as the formal freedom made available to architects enabling the implement complex design (Hager et al., 2016). However, one of the limitations of AM in construction is the lack of a comprehensive design to fabrication framework enabling the direct link between design product and its fabrication process (Kontovourkis and Konatzii, 2018). Buswell et al. 2018 observed another key challenge, which is the geometry compliance with material properties.

2.2. TOPOLOGY OPTIMISATION FOR ADDITIVE MANUFACTURING

Topology optimisation (TO) is a mathematical method of geometrical connectivity to optimise the performance of the structural system based on a given load and boundary (Leary, 2020). The implementation of TO in construction is not new. TO has been used to increase the cost-efficiency by maximising the stiffness and minimising material use in structure (Kontovourkis et al., 2020).

One of the first examples of TO in architecture is “Illa de Blanes”, a multi-space project in Spain. A digital evolutionary structural optimisation technique (ESO) was implemented in the project. Another example of a project utilising TO application is the Akutagawa office building in Takatsuki in Japan by f-tai architects, with the collaboration of structural engineer Hiroshi Ohmori in 2005. The building consists of four storeys. In this project, the extended evolutionary structural optimisation (ESO) method, was implemented as the primary optimisation process. The implementation of the ESO technique defined the shape of the walls in the building. Its architectural and structural design succeed to work in unison with the building’s facade. Other structural factors such as live, dead and earthquake loads were taken into consideration as part of the optimisation process. The final result of the TO was verified in an elastoplastic numerical model, based on structural deflections and cracking patterns (Januszkiewicz and Banachowicz, 2017). Its structural frame was made out of reinforced concrete. It required the use of a complex formwork, which is one of the limitations for implementing TO in architecture using the conventional construction method (Donofrio, 2016).

Furthermore, the Qatar National Convention Centre (QNCC) in Doha is another realised project utilising a TO technique by Ohmori and Saski in 2011 (Januszkiewicz and Banachowicz, 2017). The project developed the extend ESO method (XESO which was applied to the buildings large roof (36m wide x 150m long). Buro Happold consultancy, the project’s engineers integrated

DEVELOPING A DESIGN FRAMEWORK FOR THE 3D PRINTING PRODUCTION OF CONCRETE BUILDING COMPONENTS

parameters such as constructability and rationality of the geometry are within the design process. Thus, the optimised geometry was simplified, and the steel frame structure was proposed to speed up the construction process and reduce construction cost (Donofrio, 2016).

A voxel-based 3D model is often used in topology optimisation to create an efficient lattice structure. The word voxel stands for the representation of a pixel in 3D. The voxel 3D model is a representation of volume, not a series of boundaries. Thus, material distribution can be more efficient. In a weak area, the density will be increased and in a robust area, the density will be reduced (Bacciaglia et al., 2019; and Aremu et al., 2017).

Consequently, to the precedence presented here, we have decided to use the TO method known as ‘material distribution and boundary variation method’. It allows optimal material distribution in the optimised structure. This approach consists of the homogenisation method, Solid Isotropic Material with Penalisation method (SIMP) and ESO (Abdi, 2015). It will also be combined with voxels-based modelling, to predict the optimum material distribution/robustness based on the given variables. In broad terms, the material distribution approach is an element-based method which uses optimisation algorithms with the finite element method in order to provide a solution for a structural element, with design parameters acting as the components, or properties of the components (Bacciaglia et al., 2019). This approach is shown to be useful in topology optimisation applications when it comes to ascertaining optimal structure. Moreover, additive manufacturing technology will be used as a fabrication tool in our case study. Our aim is that by combining AM of concrete and TO we will reduce inefficient use of materials, increase safety, quality, and productivity in a construction site.

3. Research Methodology

The work presented in this paper consists of three main phases (Figure 1). Firstly, developing a design to fabrication framework for a typical single-family house using Grasshopper, Karamba plug-in, to create a parametric finite element model (FEM) for reinforced frame structure. This phase includes defining the boundary of the column, for topology optimisation, using the same dimensions used in the simulated parametric house. Secondly, testing the framework by optimising a load-bearing column, using the topology optimisation tool Millipede. Finally, 3D printing preparation of the result, using a robotic simulation tool, RoboDK, to generate robotic instructions through G-code.

We will verify this process by testing one column and compare its efficiency (material waste, labour demand, and construction duration) with a

column which has been designed and fabricated conventionally. We will only focus on the load-bearing system. Walls and finishes are not part of this research.

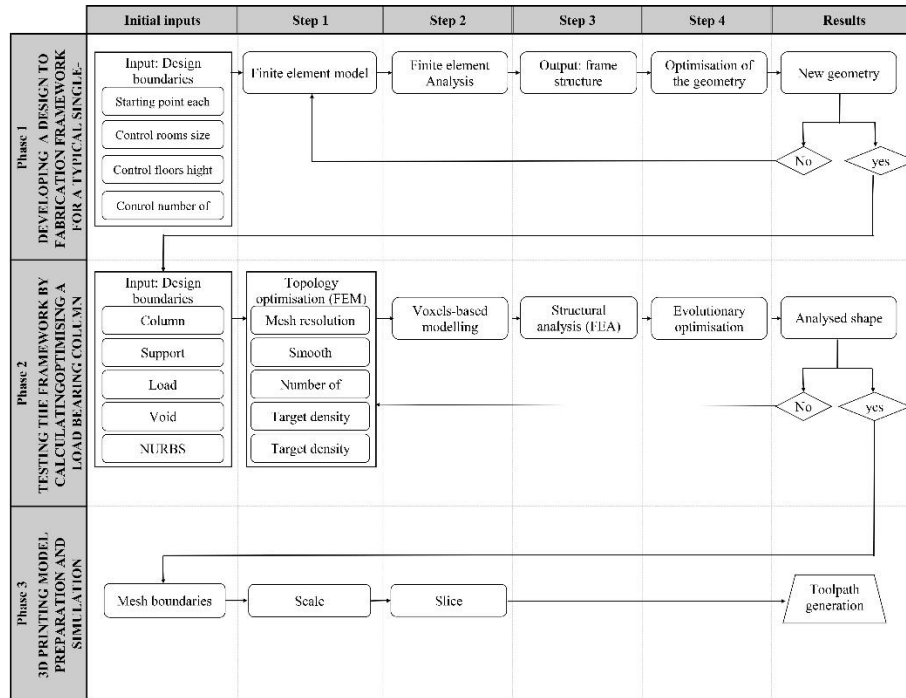

Figure 1. The workflow of the proposed design-to-fabrication framework

3.1. PHASE ONE: DEVELOPING A DESIGN TO FABRICATION FRAMEWORK FOR A TYPICAL SINGLE-FAMILY HOUSE

As a starting point, we have used the floor plans of a typical, Villa, single-family house, obtained from ‘Khatib and Alami’, an engineering consultant company working with the Saudi Ministry of Housing. We have then parametrised the house, using Grasshopper and its structural simulation tool Karamba (Figure 2). Thus, the plans can be adapted to different building sites and user needs, by adjusting parameters such as room size, floor height and number of stories (Figure 3). The algorithm produces a finite element model (FEM), which represents the framed structure of the house. The FEM is calculated according to properties set by the Saudi Building Code, such as material selection and structural performance. In addition, the house can be subdivided to individual structural rooms and their building components, such as columns, beams and slabs. In the next phase, the individual structural components are being topologically optimised and structurally verified.

DEVELOPING A DESIGN FRAMEWORK FOR THE 3D PRINTING PRODUCTION OF CONCRETE BUILDING COMPONENTS

Finally, the components are being contoured, and the 3D printing process is being simulated.

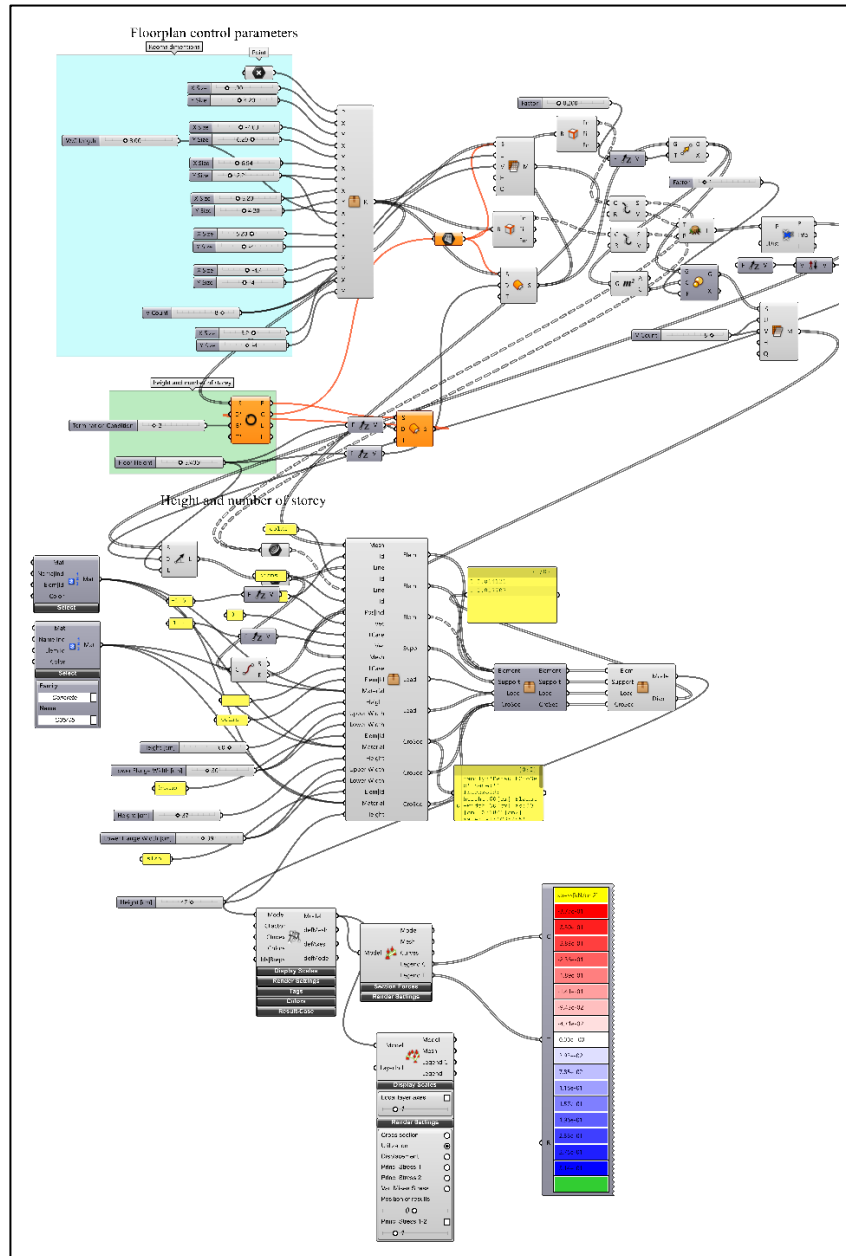

Figure 2. Grasshopper algorithm including floorplan control parameters

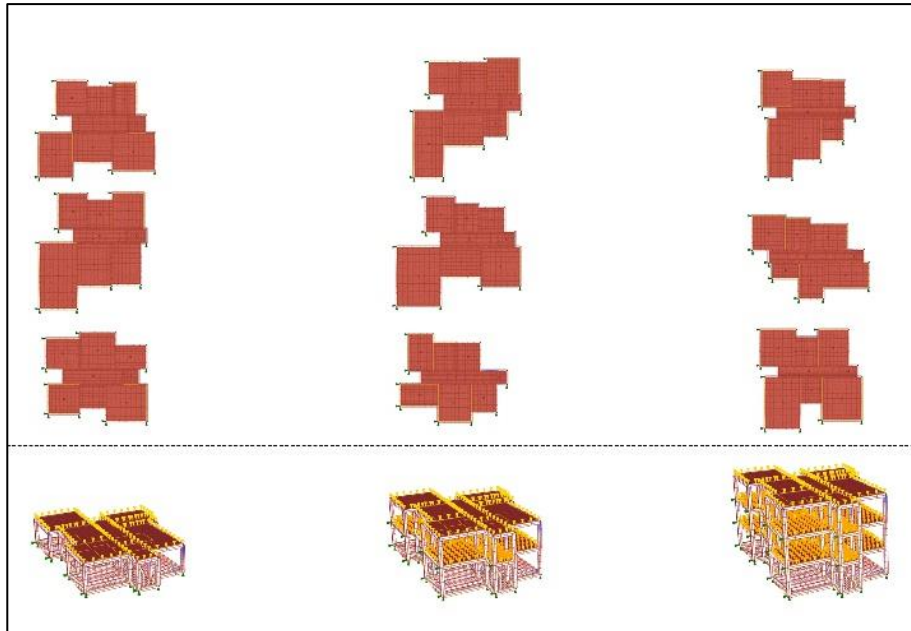

Figure 3. Different iterations showing the parametrization of floor plans and the number of stories

3.2. PHASE TWO: TESTING THE FRAMEWORK BY OPTIMISING A LOAD BEARING COLUMN

The topology optimisation and verification of the column have been conducted through three steps sequentially including 1) defining the column boundaries; 2) topology optimisation; 3) structural verification. The column boundaries were defined as a surface box with dimension of $0.3 \text{ m} \times 0.6 \text{ m} \times 3.4 \text{ m}$ (width \times length \times height). A C# script has been developed to outline the direction value (u, v) of the shape. The surface of the column was transformed into NURBS to define the frequency and amplitude and use these values as part of the optimisation process (Figure 4).

The model is then fed to the topology optimisation processor (Millipede plug-in). The applied load on the column was calculated as part of the FEM for the house that has been described in Section [3.1]. Thus, due to the fact that Karamba's units are different from the units of the inputs in Millipede, the calculated load is multiplied by 1000 to convert from kN to N.

DEVELOPING A DESIGN FRAMEWORK FOR THE 3D PRINTING
PRODUCTION OF CONCRETE BUILDING COMPONENTS

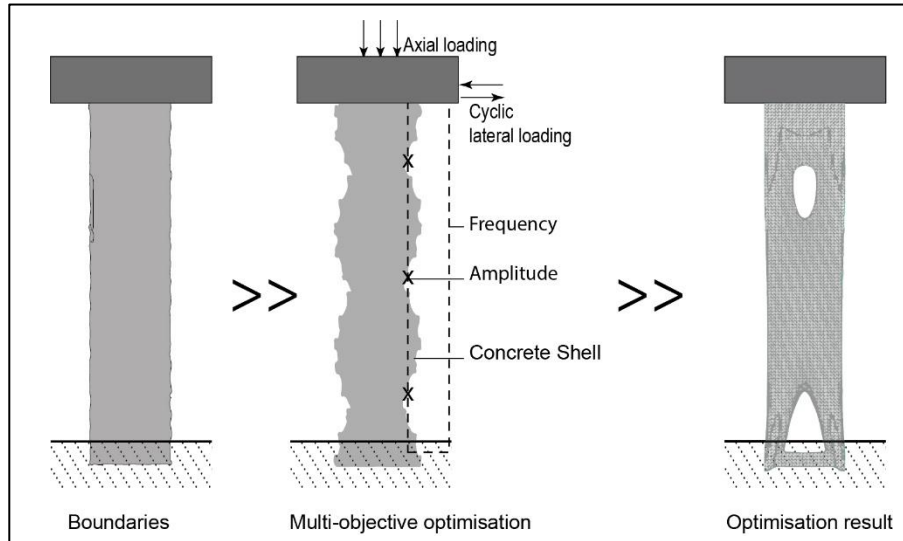

Figure 4. Defining the NURB boundaries of the column, then identifying loads and optimisation objectives

Moreover, the optimisation process works for distributing materials with minimum stress to subtract material accurately. The voxelisation based method was used, taking the advantages of the Monolith plug-in in Grasshopper. In the final step, the optimisation parameters were inputted into the evolutionary solver Galapagos, which is a heuristic solver that compare approximate solutions because the exact solution cannot be detected (Tedeschi, 2014), using genetic-algorithms in our case study. The inputs variables in Galapagos include the amplitude, frequencies, number of optimisation iterations, target density, and material density. The Galapagos solver compares different results based on the inputs variables, aiming to maximise structural stiffness and minimise structural deflection as well as coming up with optimum solutions.

In order to ensure that the Millipede plug-in can operate efficiently, the x-axis mesh resolution along had to be 12, which voxelised the main boundaries and created the primary FEM. The recommended value based on the software guidance should be between 12-40 because this number can drastically affect the time and memory consumed during the optimisation process.

After running Galapagos to compare iterations and coming up with an optimum solution based on minimum structural deflection, Karamba plug-in in Grasshopper has been used to verify the optimised structure's. The structural performance performed using FE simulation based on the Saudi building code (SBC Committee 304, 2007). The column was tested using C40 concrete with a vertical load of 31.2 kN/m^2 , and set fixed support for the base.

Karamba simulation engine allows the visualisation of stress on structural elements. The minimum stress for the resulted structure is $2.00e-02$ kN/cm², and the maximum stress is $5.00e-01$ kN/cm².

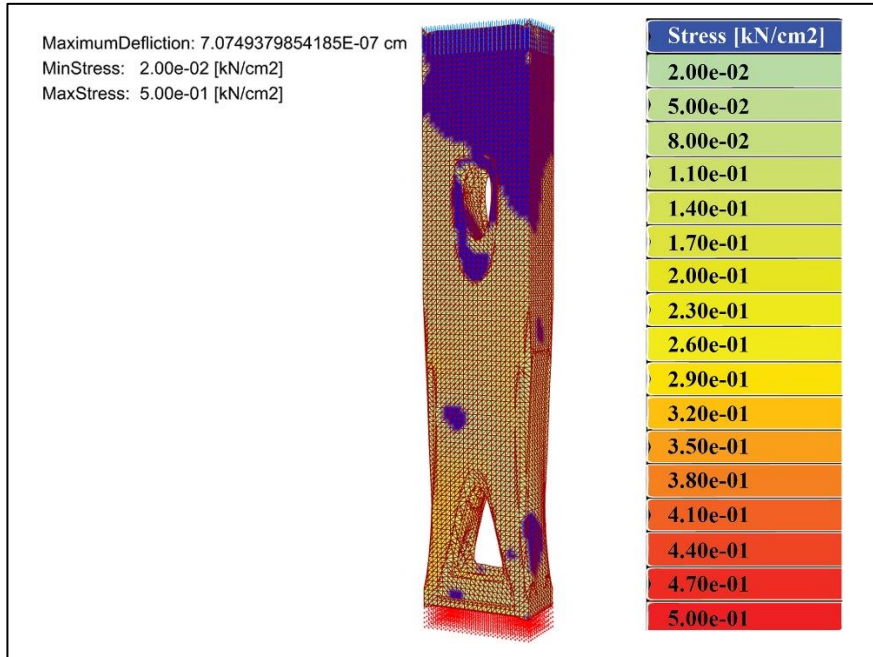

Figure 5. Simulation result of the optimised column showing maximum and minimum stress

3.3. PHASE THREE: 3D PRINTING PREPARATION AND SIMULATION

The model was contoured and scaled using the Grasshopper plug-in RoboDK, an off-line programming firmware suite used for robotic fabrication applications (Figure 6). Its integration with Grasshopper is essential for the toolpath generation. The slicing algorithm can adjust the printing layers' height and printing speed according to the material proprieties. Eventually, the 3D printing process was simulated again by using RoboDK. The layer height is 5cm, with a printing speed of 50 mm/second. However, these variables are parameters and can be modified based on material proprieties.

DEVELOPING A DESIGN FRAMEWORK FOR THE 3D PRINTING PRODUCTION OF CONCRETE BUILDING COMPONENTS

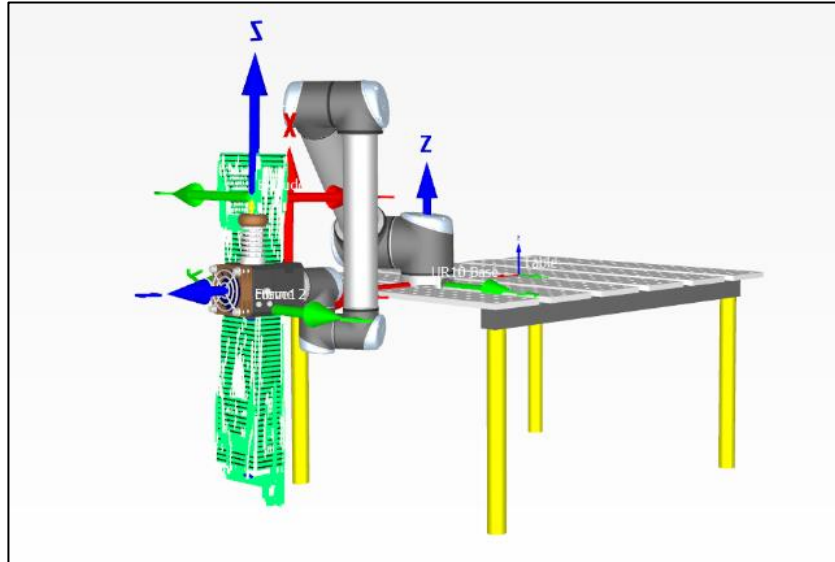

Figure 6. 3D printing simulation

4. Findings and Conclusion

The optimisation and 3D printing simulation of a typical column have demonstrated the efficiency of implementing our framework in real-world scenarios in Saudi Arabia, to improve issues related to labour shortage, construction duration, and cost. By comparing the material usage in both conventional and optimised columns, we found out that material consumption has been reduced by 25%. The use of robotic technologies alongside additive manufacturing can mitigate the required labour in construction site by 28%. Besides, the duration time will be reduced by 80% as the column will be printed in one go, without the need for formwork. According to our calculations, it will improve the overall cost-efficiency compared to the conventional construction method as shown in *Figure 7*.

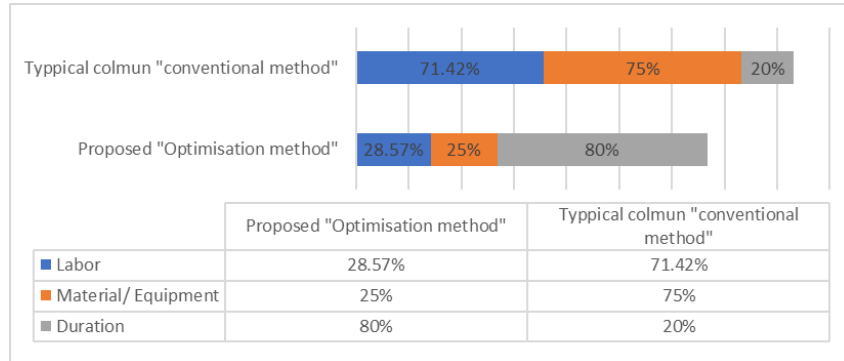

Figure 7. Comparison between conventional construction of a column with the digitalised method

Besides, the key features of our proposed approach are the fulfilment of user needs by enabling future clients to customise the design for their houses. Conventionally, the design process starts with an architect and an engineer, followed by the client's approval. If a client was not satisfied, the whole process must start again. In our approach, the clients can adjust the design parameters based on their individual needs. It is considered to be more time-efficient compared with current conventional construction in the country (Figure 8).

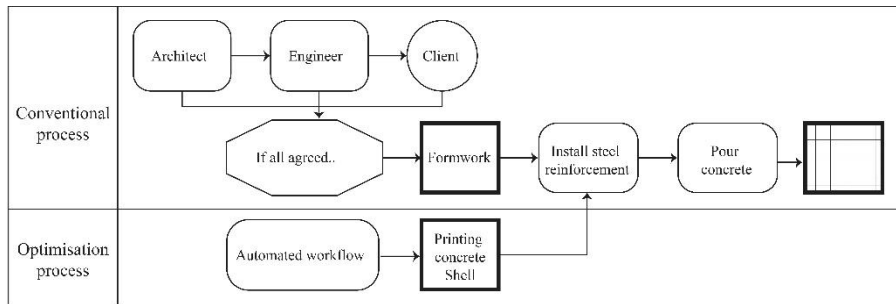

Figure 8. Comparison between procedures between conventional and proposed construction method

Furthermore, the reinforced-concrete frame structure of a typical house can be optimised and prepared for 3D printing by abstracting the building to its essential structural components (columns, beams, and slabs). The topology optimisation, performing on the column, shows that the specific implemented method is able to adapt the applied loads. It takes into consideration the limitations of the chosen materials. This method works to maximise structure stiffness and minimise material consumption. For structural verification, we

DEVELOPING A DESIGN FRAMEWORK FOR THE 3D PRINTING PRODUCTION OF CONCRETE BUILDING COMPONENTS

have used FE analysis to assure structural stability. However, to adapt the proposed method with the current Saudi Code, we propose using steel bars to infill the inner patterns with proper reinforcement. This can be done through a second round using FE analysis with authentic materials proprieties that will be used in the fabrication process. The optimisation presents its potential to be introduced for robot toolpath through slicing algorithms, which will be connected to RoboDK to generate G-code.

Finally, due to the nature of this project, our next steps will include the fabrication of a full-scale physical model in order to compare the physical process with the one simulated and presented here.

References

- Abdi, M., 2015. Evolutionary topology optimisation of continuum structures using X-FEM and isovalues of structural performance. Univ. Nottingham PhD thesis.
- Alhajri, A.R., Alshibani, A., 2018. Critical factors behind construction delay in petrochemical projects in Saudi Arabia. *Energies* 11, 1–18. <https://doi.org/10.3390/en11071652>
- Alhubashi, H., 2018. HOUSING SECTOR IN SAUDI ARABIA: PREFERENCES AND ASPIRATIONS OF SAUDI CITIZENS IN THE MAIN REGIONS. Universidad Polit cnica de Catalu a.
- Alqahtany, A., Mohanna, A. Bin, 2019. Housing challenges in Saudi Arabia : the shortage of suitable housing units for various socioeconomic segments of Saudi society 22, 162–178. <https://doi.org/10.1108/HCS-01-2019-0002>
- Aremu, A.O., Brennan-Craddock, J.P.J., Panesar, A., Ashcroft, I.A., Hague, R.J.M., Wildman, R.D., Tuck, C., 2017. A voxel-based method of constructing and skinning conformal and functionally graded lattice structures suitable for additive manufacturing. *Addit. Manuf.* 13, 1–13. <https://doi.org/10.1016/j.addma.2016.10.006>
- Bacciaglia, A., Ceruti, A., Liverani, A., 2019. A systematic review of voxelisation method in additive manufacturing. *Mech. Ind.* 20, 630. <https://doi.org/10.1051/meca/2019058>
- Buswell, R.A., Leal de Silva, W.R., Jones, S.Z., Dirrenberger, J., 2018. 3D printing using concrete extrusion: A roadmap for research. *Cem. Concr. Res.* 112, 37–49. <https://doi.org/10.1016/j.cemconres.2018.05.006>
- Comminal, R., Leal da Silva, W.R., Andersen, T.J., Stang, H., Spangenberg, J., 2020. Modelling of 3D concrete printing based on computational fluid dynamics. *Cem. Concr. Res.* 138, 106256. <https://doi.org/10.1016/j.cemconres.2020.106256>
- Donofrio, M., 2016. Topology Optimisation and Advanced Manufacturing as a Means for the Design of Sustainable Building Components. *Procedia Eng.* 145, 638–645. <https://doi.org/10.1016/j.proeng.2016.04.054>
- Government of Saudi Arabia, 2016. Vison 2030 Kingdom of Saudi Arabia, Report. Government of Saudi Arabia.
- Hager, I., Golonka, A., Putanowicz, R., 2016. 3D Printing of Buildings and Building Components as the Future of Sustainable Construction? *Procedia Eng.* 151, 292–299.

- <https://doi.org/10.1016/j.proeng.2016.07.357>
- Januszkiewicz, K., Banachowicz, M., 2017. Nonlinear Shaping Architecture Designed with Using Evolutionary Structural Optimization Tools. IOP Conf. Ser. Mater. Sci. Eng. 245. <https://doi.org/10.1088/1757-899X/245/8/082042>
- Kontovourkis, O., Konatzii, P., 2018. Design-static analysis and environmental assessment investigation based on a kinetic formwork-driven by digital fabrication principles. Odysseas Kontovourkis (ed.), Sustain. Comput. Work. [6th eCAADe Reg. Int. Work. Proceedings], Dep. Archit. Univ. Cyprus 131–140.
- Kontovourkis, O., Tryfonos, G., Georgiou, C., 2020. Robotic additive manufacturing (RAM) with clay using topology optimisation principles for toolpath planning: the example of a building element. *Archit. Sci. Rev.* 63, 105–118. <https://doi.org/10.1080/00038628.2019.1620170>
- Leary, M., 2020. Design for additive manufacturing.
- Mechtcherine, V., Nerella, V.N., Will, F., Näther, M., Otto, J., Krause, M., 2019. Large-scale digital concrete construction – CONPrint3D concept for on-site, monolithic 3D-printing. *Autom. Constr.* 107, 102933. <https://doi.org/10.1016/j.autcon.2019.102933>
- Saudi Ministry of Housing, 2016. The Housing Program Delivery Plan. Government of Saudi Arabia.
- SBC Committee 304, 2007. Structural - Concrete structures 274.
- Tedeschi, A., 2014. Algorithms Aided Design. Le Penseur.
- Theodore Karasik, 2017. Saudi Housing Requirements for a Strong and Secure Future [WWW Document]. *Int. Policy Dig.* URL <https://intpolicydigest.org/2017/06/09/saudi-housing-requirements-strong-secure-future/>

DOUBLE GREEN FACADES USING PARAMETRIC SUSTAINABLE DESIGN

A Simulation Tools with Parametric Approach to Improve Energy Performance of office building in Egypt

AYAH MOHAMED RAMADAN

Modern academy for engineering and technology

Email address: ayahezzat54@gmail.com

Abstract. Parametric Sustainable design of the indoor environment of double green façades buildings focus on the development of office building structure in Egypt and achieved indoor thermal comfort at a low level of energy use. The goal of this paper is to study parametric design from a wide perspective in order to classify its advantages and evaluate its skill to support Sustainable design. As building construction sector is the largest energy consumer, Operation hours of air conditioners is speedily increasing in the office buildings area through summer season, which already accounts for 50% of energy consumption in Egypt. This study was carried out based on the simulation in Design Builder (6) software. The case, studied in the article is for office building, newly erected building with surface area of 25, 500 m² is considered as the basis for the parametric Sustainable study. The new energy model was simulated resulting in about 70% in HVAC consumption and approximately 75% for whole building energy consumption. Analysis results showed that parametric optimization of building envelope at the design stage is a practicable approach to reducing energy consumption in office building design.

Keywords: *Double green facades, Parametric Sustainable design, Energy Performance, Thermal comfort*

ملخص. يركز التصميم المعياري المستدام للبيئة الداخلية للمباني ذات الواجهات الخضراء المزدوجة على تطوير هيكل مبنى المكاتب الادارية في مصر وتحقيق الراحة الحرارية الداخلية عند مستوى منخفض من استخدام الطاقة. الهدف من هذا البحث هو دراسة التصميم البارامتري من منظور واسع من أجل تصنيف مزاياها وتقييم مهارتها لدعم التصميم المستدام. نظرًا لأن قطاع تشييد المباني هو أكبر مستهلك للطاقة ، فإن ساعات تشغيل مكيفات الهواء تتزايد بسرعة في مباني الادارية خلال موسم الصيف ، والتي تمثل بالفعل 50٪ من استهلاك الطاقة في مصر. أجريت هذه الدراسة بالاعتماد على المحاكاة لبرنامج

Design Builder (6) الحالة التي تمت دراستها في البحث ، تتعلق بمباني المكاتب الادارية، ويعتبر المبنى الذي تم تشييده حديثاً بمساحة 25500 متر مربع كأساس للدراسة البارامترية المستدامة. تمت محاكاة نموذج الطاقة الجديد مما أدى إلى حوالي 70٪ من استهلاك التدفئة والتهوية وتكييف الهواء وحوالي 75٪ لاستهلاك طاقة المبنى بالكامل.

الكلمات المفتاحية: واجهات خضراء مزدوجة ، تصميم مستدام البارامترى ، أداء للطاقة ، راحة حرارية.

1. Introduction

In Egypt, residential, industrial, and institutional buildings account for more than 55 % of overall electricity use. With a growth rate of 6.8%, a significant increase in electricity demand is estimated over the next few years (Ministry of Housing,2005). One of the significant architectural skins of energy-efficient buildings represents the features of the Building Envelope. In Egypt, the combination of thermal comfort in commercial buildings is rarely measured inappropriately.

Also, the lack of any major analyses to evaluate the cost-effectiveness of air conditioning control strategies in Egyptian buildings in budgets can explain the reluctance of architects to implement energy efficiency in their designs EEHC (2013). Egypt's primary energy sources include natural gas, petroleum products, and electricity. Electricity is produced primarily from power plants powered by primary sources of energy. The growth in global energy demand has reached approximately 140.2 trillion kWh with an annual increase of 7.5 % in energy demand (Attia,2012), where the industry takes about 28.4%, Residential 42.6%, commercial buildings 10.4%, and street lighting 4.4% while Agriculture has only 4.4%.

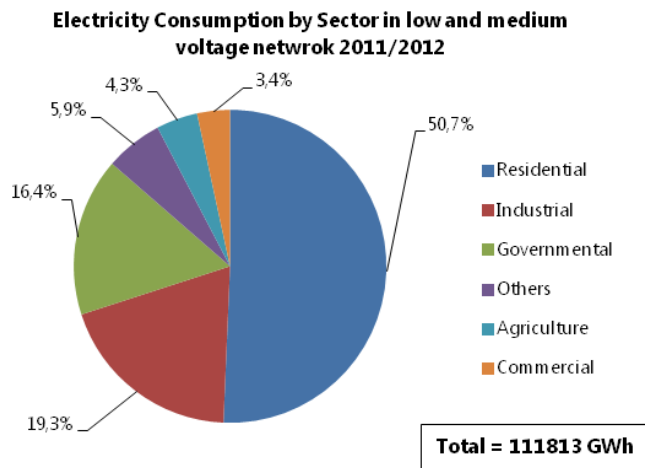

Figure 1. Electricity consumption by sector at low and medium voltage network for 2011/2012 (Egyptian Electricity Holding Company, 2013).

DOUBLE GREEN FACADES USING PARAMETRIC SUSTAINABLE DESIGN

As shown in Fig. 1, about 20 percent of the overall energy consumption is absorbed by the commercial and governmental industries. Nowadays, energy saving studies are important for that. Nearly 3 kW h of electricity is needed to distribute 1 kW h to consumers, as electricity has an efficiency of approximately 33 % (American Society of Heating,2009). So, a significant amount of energy generated can be avoided by saving some small portion of electricity.

2. Main goal

Enhancement and optimization of energy performance within office buildings in Cairo by selecting the best thermal performance façade. The research focuses on south-facing glazed office building façades and the means to optimize the façade design concerning traditional glazing facade.

The objective of this research is to reach the optimum range in the office buildings to give the maximum behavior of double skin façades combining with a green wall. This is performed by using parametric modeling tools to optimize office building facades in Egypt. The aim is to reduce energy consumption in office buildings see figure. 2.

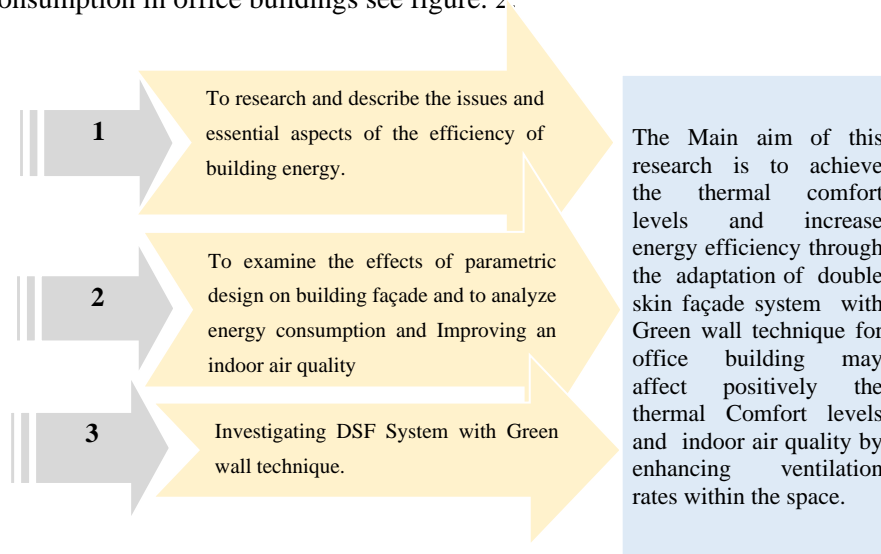

Figure 2. Research Objectives Chart.

3. Problem Definition

Office buildings are considered the highest energy users among various building types (International Energy Agency, 2003), where people work for an average of 8 hours a day during the peak time of energy demand

(Egyptian Government, 2011). Energy saving is therefore the urgent aim of the Egyptian government. The pressing need of Double Skin Façade design combining with greening system classification including to enhance the relation between Facades and Energy Consumption. The lack of a awareness of the importance of Double green facades Technology on wide range & lack of its usage in Egypt while we need it due to our climate.

4. Office buildings in Egypt

The challenges faced by architects in designing fully glazed southern façades of buildings lie in the presence of many criteria that need to be considered, such as glare, energy usage, light requirements, and finally, the building's aesthetic value (Sayed and Fikry, 2019), as shown in figure 3.



Figure 3. Office buildings in Cairo, Egypt with curtain wall façades facing west and south.

4.1. THE FACADE AS AN INTERFACE BETWEEN INTERIOR AND EXTERIOR

Building facades serve two functions: first, they are the obstacle separating the interior of a building from the external environment (Premier, 2012). Climate-adaptive facades are not only enveloping between the inside and outside structures; rather, they are building constructions that generate comfortable areas through the consumption of natural lighting, HVAC, shading, etc. (Gadelhak,2013).

4.2. EXAMPLE 1: COUNCIL HOUSE 2 (CH2), MELBOURNE, AUSTRALIA

CouncilHouse2 (CH2) has been planned as a creative, sustainable office building for the city of Melbourne (Webb,2005). Nature is used as inspiration for façades that combine moderate environment, tapered ventilation ducts with daylighting techniques, see figure 4. Based on its high-performance façade, the building has received many awards in the field of environmental planning and sustainable design (Jones, 2008).

DOUBLE GREEN FACADES USING PARAMETRIC SUSTAINABLE DESIGN



Figure 4. CH2 is the City of Melbourne's landmark green office building. Located at Little Collins

5. High Performance Façade (HPF)

High-performance facades can be described as exterior additions that assistance the minimum achievable quantity of energy consumption (Aksamija, 2013). The goal of a high-performance façade to create comfortable spaces by a) developing building orientation, geometry and massing; b) allowing shading strategies; c) enhancing natural ventilation; d) maximizing natural lighting and minimizing energy used for artificial lighting (Gadelhak, 2013). Different design strategies can be used in designing high-performance building façades as shown in figure 5.

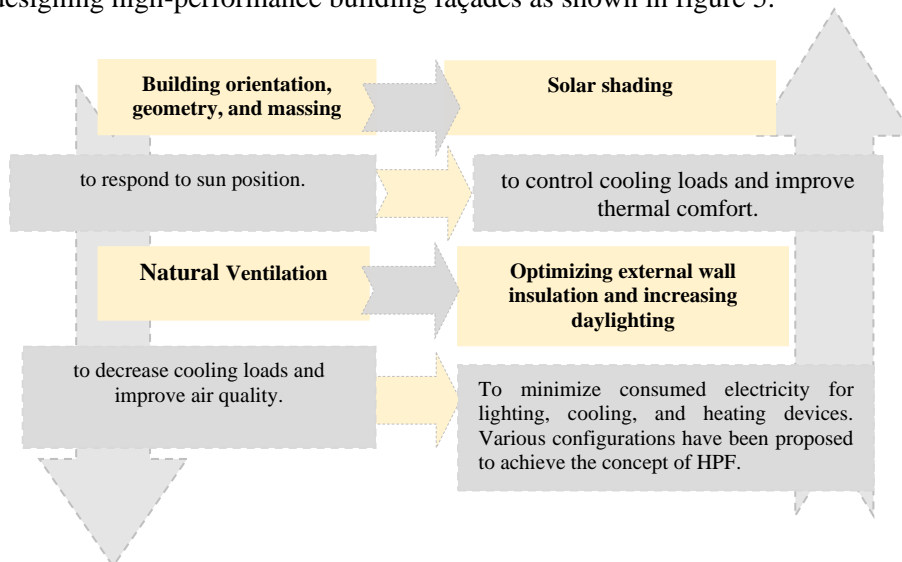

Figure 5. Parameters of high-performance façade.

6. Vertical Greenery System (VGS)

It is possible to split the vertical greenery system into two categories (support and carrier), according to Chiang and Tan (2009). Support systems are prepared for the laying of plants on vertical surfaces, whereas support systems are referred to as planting media on vertical walls, while carrier systems are able to involve more categories of plants, including shrubs, ground-covers, sedges, ferns, grasses, and even mosses (See figure 6).

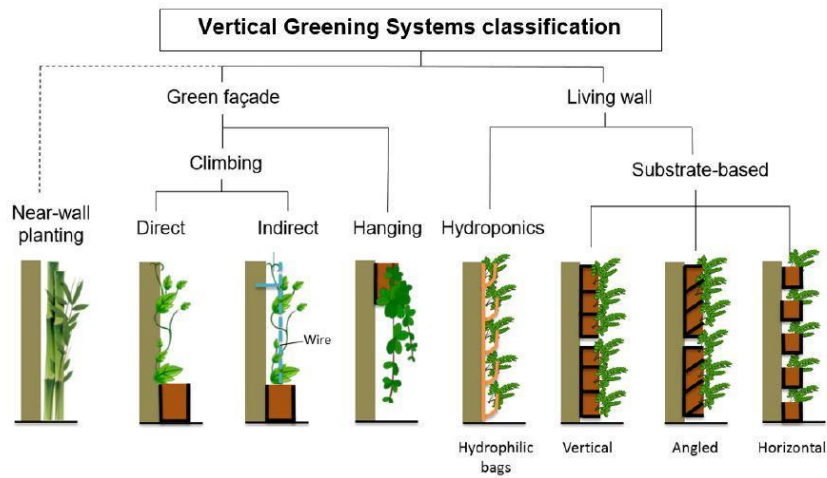

Figure 6. Vertical Greenery Systems classification. (Ottelle, 2011)

7. Parametric design

The definition of the word 'Parametric Design' is clear, to describe it is somehow difficult. Parametric facade is building envelopes that can regulate to exchanging climatic conditions on an hourly, daily, seasonal, or yearly origin (Luible, 2014). Various configurations have been planned to achieve the concept of parametric façade. Each form is brief in the following points as shown in figure 7.



Figure 7. Capricorn House (left), Al Bahr Towers(right).

8. The Double Skin Façade (DSF) system

The Double Skin Façade is a system consisting of two glass skins placed in such a way that air can flow in the intermediate cavity. Usually, the width between the skins ranges from 20 cm to 2 m. The solar shading devices are located within the cavity for security and heat extraction purposes. The ventilation of the cavity can be natural, fan-aided, or mechanical; the origin and destination of the air can also vary depending on the HVAC technique of the construction (Poirazis, 2004). Basic DSF types include: – Box window façades, Corridor façades, Shaft box façades and Multi-storey façades as shown in figure 8.

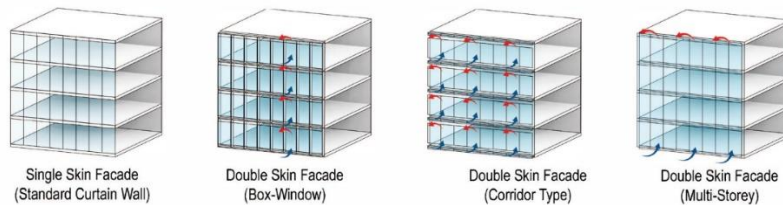

Figure 8. Diagram showing investigated façade types, where the basic components and airflow patterns are indicated.

Basic DSF types include: – **Box window façades**, which have horizontal partitions at each floor level, as well as vertical partitions between windows. Each air cavity is typically ventilated naturally.

– **Corridor Façades**, which have uninterrupted horizontal air cavities for each floor level but are physically partitioned at the floor levels.

– **Multi-Storey Façades**, which have uninterrupted air cavities spanning the full height and width of the façade.

9. Methodology

Design builder is relied on device primarily based totally on Energy plus this is funded via way of means of the U.S. Department of Energy Building. It becomes selected as a simulation device because of its accuracy and correspondence to the bottom case (see table 1).

TABLE 1. General Office Building Design Data

Building type/Room	Office building/12 person/100 m ²
Building floors numbers/ Building total height	Ground floor + (3) typical floors/ (4.0 m * 4 floors) + 2.0 m parapet of façade= 18.0m
Ventilation system	For "Base-Case" building: Artificial Mechanical ventilation (Full HVAC) system For V.DSF building: 'Mixed-Mode' (Hybrid) system all of the year

TABLE 2. Seven scenarios of simulation structure.

1		Double Skin facades		
		Box window DSF.	Corridor type DSF.	Multi-story DSF.
Base Cases				
2		Double green facades		
		Green-Box window DSF.	Green-Corridor type DSF.	Green-Multi-storey DSF.
Retrofit Cases				

Thus, there are seven scenarios to simulate in this study: base building, Box-DSF, Corridor DSF, and Multi DSF. Furthermore, the simulation results are compared from three faces (Green Box-DSF, Green Corridor DSF, and Green Multi DSF), as shown in Table 2 to find the optimal energy performance solution for each side. Two controllable vents with a height of 0.5m are installed on the top and bottom of DSF. The DSF cavity is separated on each level by a grill, which is simulated as three controllable

DOUBLE GREEN FACADES USING PARAMETRIC SUSTAINABLE DESIGN

internal windows. The DSF opening and vents allow natural ventilation in the summer months (December to February) and night-time ventilation during the other months. During the other times of the year, they can be shut tightly. The steps are taken in this study are illustrated in Figure 9. DSF and GW are implemented 1.5 meter away from each façade of the base building one at a time. The exterior skin of DSF is 100% glazing. Two controllable vents with a height of 0.5m are installed on the top and bottom of DSF.

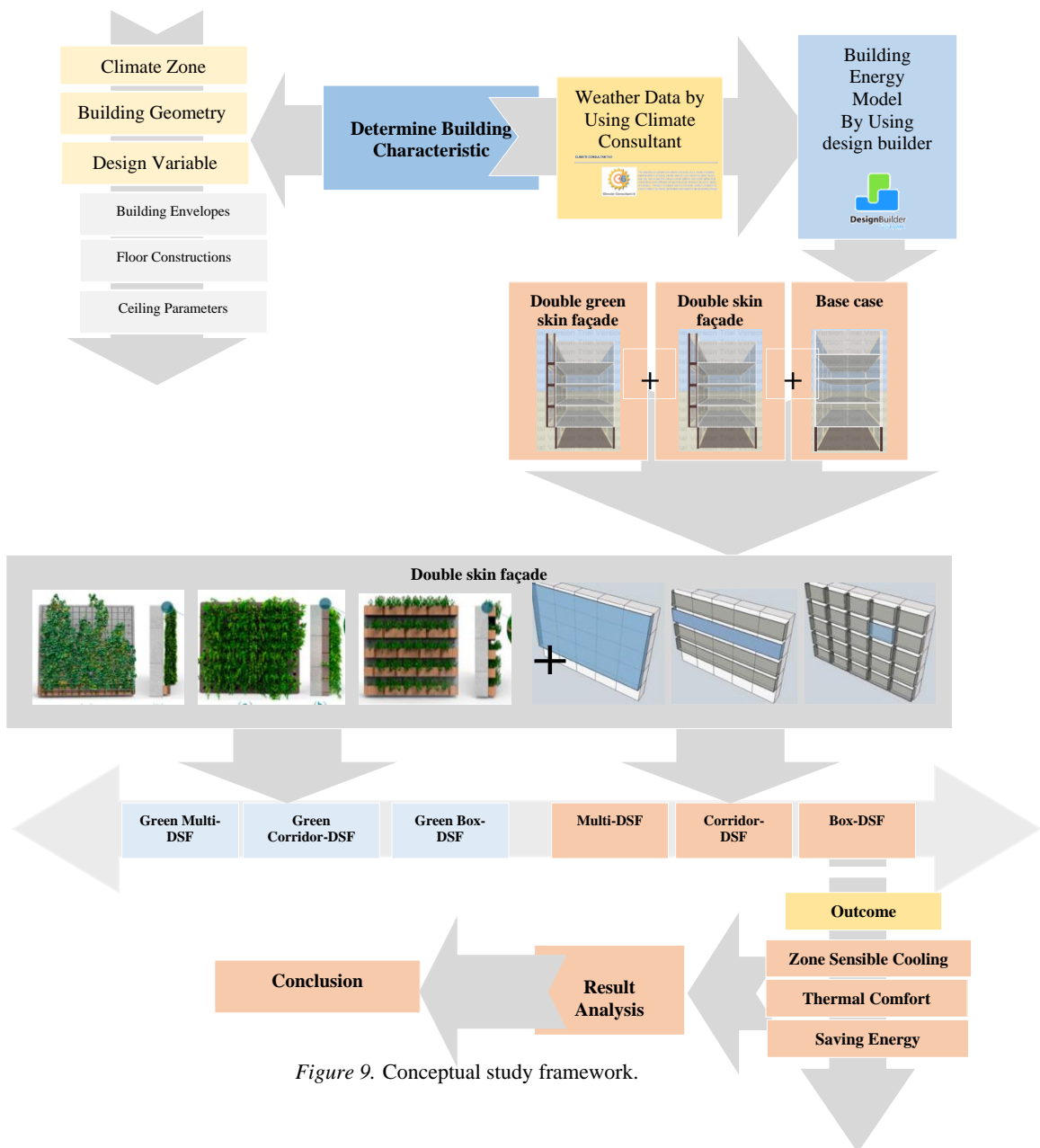

Figure 9. Conceptual study framework.

10. Results and Discussion

The performance of a building is affected by the type of façade along with each orientation of the building. The simulations show how changes along each green wall affect the energy performance with a different type of double-skin façade.

A-Effect of Façade on Peak Summer Cooling Loads: Green Corridor façade with optimal cavity depth 2m.

The overall energy consumption within the office area is evaluated under the effect on the cooling loads in relation to the use of various combinations of Double-Skin Façade configurations, systems, with a constant orientation (south) and depth (2.0 m). In order to provide an accurate comparison of results, the energy consumption related to cooling loads for a conventional single-skin façade is also evaluated.

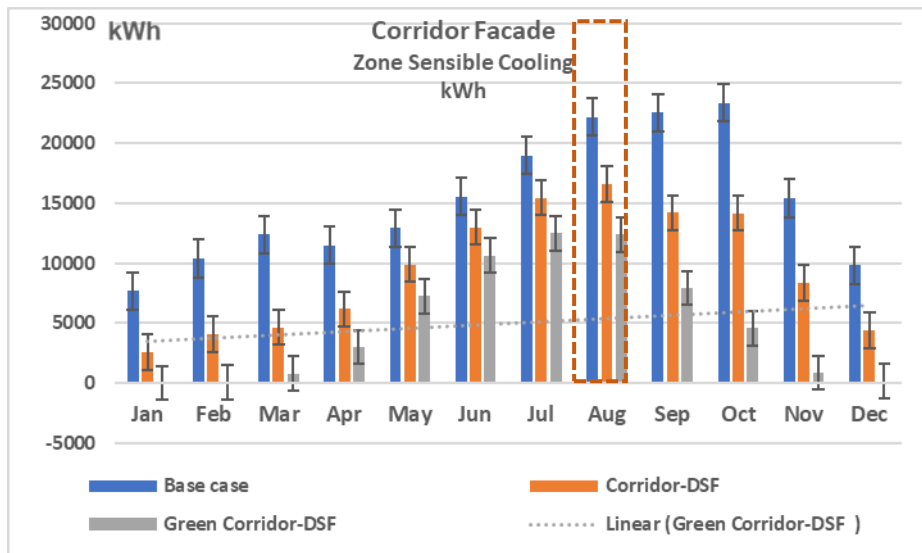

Figure 10. Building energy consumption in different scenarios of Corridor DSF.

Figure. 10 Shows the Effect of applying Corridor and green DSF on annual sensible cooling with optimum air cavity width 2.0m with 16616 kWh & 12410 kWh compared to the base case 22215 kWh at south façade respectively.

DOUBLE GREEN FACADES USING PARAMETRIC SUSTAINABLE DESIGN

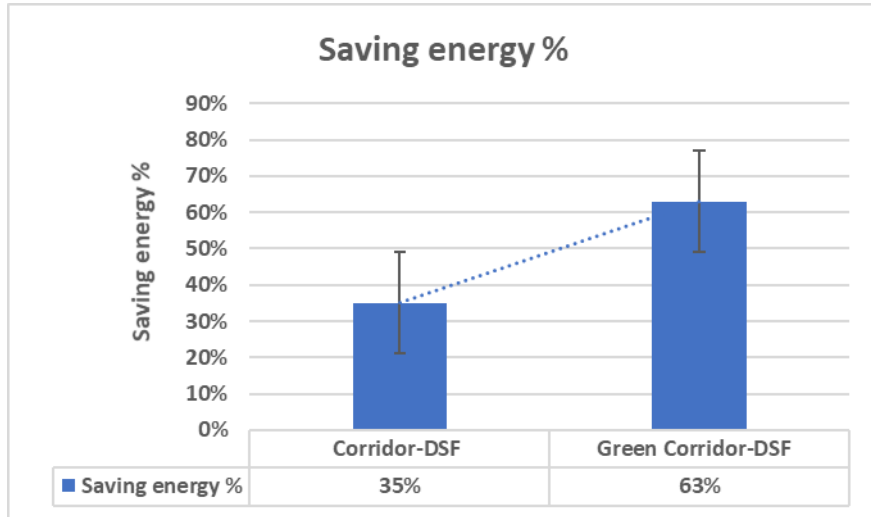

Figure 11. Saving energy for Corridor & Green Corridor DSF Façade.

Figure.11 Shows the Effect of applying Corridor and green DSF on Saving Energy with a 2.0m air cavity width, it reached up to 35% and 63% for the south orientation respectively.

B- Effect of Façade on Peak Summer Cooling Loads: Green Multi façade with optimal cavity depth 2m.

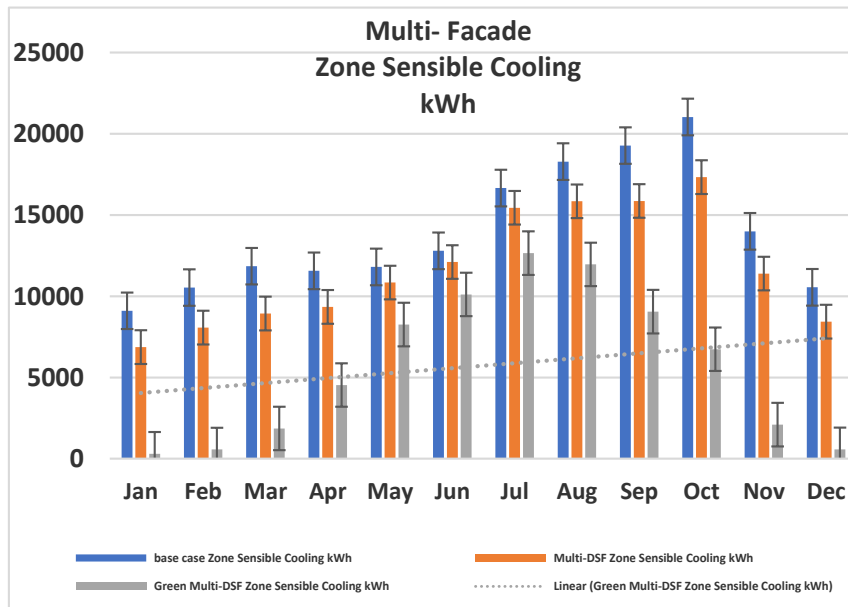

Figure 12. Building energy consumption in different scenarios of Multi DSF.

Figure. 12 Shows the impact of the application of multi and green DSF on annual appropriate cooling with an optimum air cavity width of 2.0 m at 15843 kWh and 11959 kWh compared to the base case of 18285 kWh in August, the hottest month of the year on the south façade, respectively. Figure.13 shows the Effect of applying Multi and green DSF on Saving Energy with a 2.0m air cavity width, it reached up to 15% and 54% for the south orientation respectively.

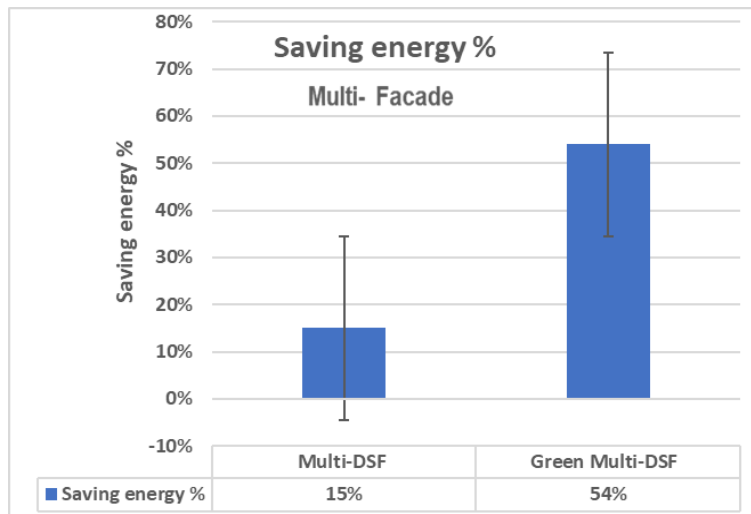

Figure 13. Saving energy for Multi & Green Multi DSF Façade.

C- Effect of Façade on Peak Summer Cooling Loads: Green box façade with optimal cavity depth 2m.

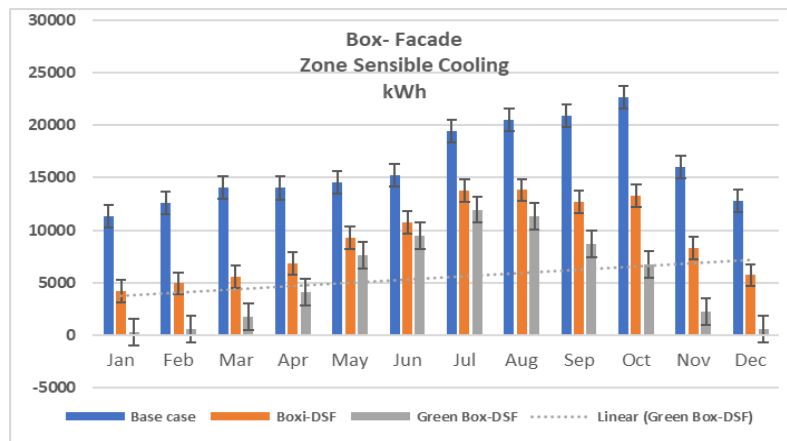

Figure 14. Building energy consumption in different scenarios of Box DSF.

DOUBLE GREEN FACADES USING PARAMETRIC SUSTAINABLE DESIGN

Figure. 14 Shows the impact of the application of Box and green DSF on annual appropriate cooling with an optimum air cavity width of 2.0 m at 13825 kWh and 11362 kWh compared to the base case of 20534 kWh in August, the hottest month of the year on the south façade, respectively.

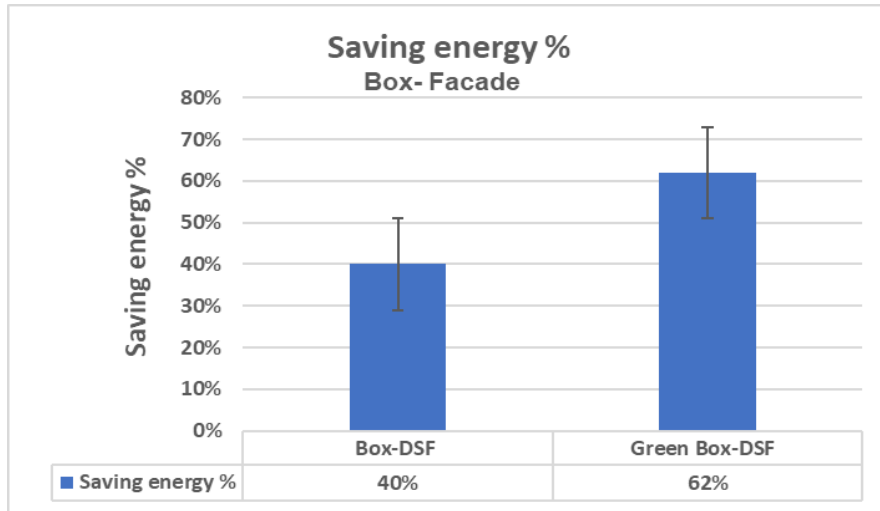

Figure 15. Saving energy% for Box & Green Box DSF Façade.

Figure.15 shows the impact of the application of Multi and Green DSF on Saving Energy with an air cavity width of 2.0 m, for the south orientation up to 40% and 62% respectively.

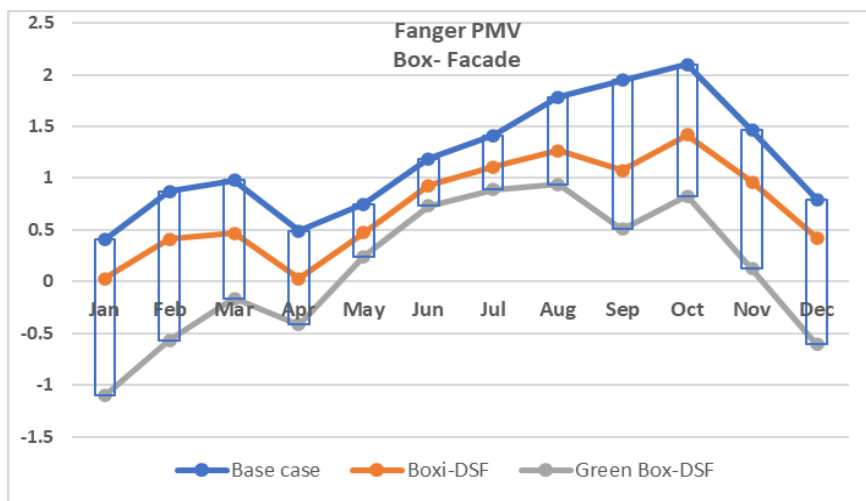

Figure 16. Monthly results of Fanger PMV for Box DSF & Green Box -DSF types at South orientation.

Figures 16, When the Fanger PMV was applied to the Box DSF & Green Box-DSF configuration and the base case, it was clear that they were both between the range of (-1 to 1). While the base case reached above 4, the Green Box-DSF type was still the most effective.

Conclusion

To improve the sustainability of the built environment, energy efficiency in buildings is important to remember. The work in this study introduced a methodological framework in an attempt to design better energy-performing buildings that could help incorporate the style of double skin façade with the green wall in order to explore all possible design variables that affect the energy levels of buildings. Our study only explored the cooling and energy-saving performance of double skin façade intermixing with green walls on a typical summer month. The cooling performances of different DSF-green walls type indicated that the measured energy consumption were all significantly affected by the type of green wall. The green Box DSF was showed the best performance in saving energy followed by the green multi DSF based on boxes and green corridor DSF wall.

References

- American Society of Heating, Refrigerating and Air-Conditioning Engineers **Advanced Energy Design Guide for Small Hospitals and Healthcare Facilities** 978-1-933742-66 3, America Society of Heating, Refrigerating and Air Conditioning Engineers, Inc. (2009)
- Aksamija, A. (2013)"Sustainable Facades: Design Methods for High Performance Building Envelopes", Published by John Wiley & Sons, Inc. Hoboken, New Jersey, Canada.
- AKSAMIIJA, A., 2015. High-Performance Building Envelopes: Design Methods for EnergyEfficient Facades. In proceedings of the 4th Building Enclosure Science and Technology Conference (BEST 4), Kyoto 13-15 Apr. 2015, 1-2.
- Aksamija, A. (2009). Integration in architectural design: methods and implementations. Design Principles and Practices: An International Journal, Vol. 3, pp. 151-160.
- Chiang, K., & Tan, A. (Eds.). (2009). Vertical greenery for the tropics (First Edit.). Singapore: National Parks Board.
- Egyptian Government, 2011. Egyptian Government Services Portal. [Online] Available at: <http://www.egypt.gov.eg/english/laws/labour/>
- Egyptian Electricity Holding Company (2013). Annual Report 2011/2012. Arab: Republic of Egypt, Ministry of Electricity and Energy. <http://www.egelec.com/mysite1/annual%20report/annual%20report.htm>
- Energy Efficiency Commercial Building Code, Ministry of Housing, HBRC, Egypt, 2005.
- Egyptian Electricity Holding Company, Annual Report 2011/2012, MOEE, Egypt, 2013.
- Gadelhak, M. (2013)"High Performance Facades: Designing Office Building Facades to Enhance Indoor Daylighting Performance", M.Sc. department of Architecture, faculty of Engineering, Ain University, Egypt.

DOUBLE GREEN FACADES USING PARAMETRIC SUSTAINABLE DESIGN

- Gadelhak, M. (2013)"High Performance Facades: Designing Office Building Facades to Enhance Indoor Daylighting Performance", M.Sc. department of Architecture, faculty of Engineering, Ain University, Egypt.
- International Energy Agency, 2003. I.E.A. [Online] Available at: <http://www.iea.org/>
- Jones, W. (2008)"Council House 2, Melbourne: Australia's greenest office building", <http://www.building.co.uk/story.asp?storycode>
- Luible A, Memorandum of understanding for the implementation of a European Concerted Research Action designated as COST Action TU1403: Adaptive Facades Network. COST Action TU1403; 2014.
http://w3.cost.eu/fileadmin/domain_files/TUD/Action_TU1403/mou/TU1403-e.pdf
- Ministry of Electricity and Energy (2014). Egypt's National Energy Efficiency Action Plan (NEEAP): Ministry of Electricity and Energy, Arabic version.
- Olgay, Victor and Vladimir Olgay, Design with Climate, Princeton University Press, 196.
- Premier, (October 2012). "Dynamic Facades and Smart Technologies for Building Envelope Requalification". Research Gate. https://www.researchgate.net/publication/269690115_DYNAMIC_FACADES_AND_SMART_TECHNOLOGIES_FOR_BUILDING_ENVELOPE_REQUALIFICATION.
- Poirazis, H., 2004. Double skin facades for office buildings; a literature review. Division of Energy and Building Design, Department of Architecture and Built Environment, Lund Institute of Technology, Lund University, Sweden. ISBN 91- 85147 – 02 -8.
- SHARAIDIN, K., 2014. Kinetic facades: towards design for environmental performance, PhD thesis, Architecture and Design, RMIT University, iv.
- S. Attia, A. Evrard, E. Gratia, Development of Benchmark Models for the Egyptian Residential Buildings Sector, Elsevier, 2012, p. 16
- Sayed, A. AND Fikry, M.,2019. Impact of glass facades on internal environment of buildings in hot arid zone, Alexandria Engineering Journal, 58, 1063–1075
- Webb, S. (2005)"The Integrated Design Process of CH2", Architecture press, Environment Design Guide.
- WIGGINTON, M., & HARRIS, J., 2013. Intelligent skins. UK: Routledge, 23.

MAN-MACHINE INTERACTION IN THE EVALUATION OF AIRPORT DESIGN PROCESS IN BRAZIL

ÍTALO GUEDES, MAX ANDRADE

*Federal University of Pernambuco, Av. Prof. Moraes Rego, 1235 -
Cidade Universitária, Recife, Pernambuco, Brazil*

Email address: italo.guedes@ufpe.br

Email address: max.andrade@ufpe.br

Abstract. This paper addresses the use of BIM for code verification and automatic validation of the Airports Design (AD). In Brazil, the evaluation and approval of AD are carried out by INFRAERO. Currently, designs are evaluated manually, resulting in errors and long evaluation time. To deal with this problem, a conceptual framework for automated AD assessment with Code Checking is proposed. The method used was Design Science Research, with the proposal of an artifact. The partial results show man-machine interaction as a way more efficient to evaluate the airport design process in Brazil. This man-machine interaction its leads to a mixed model evaluation, with the use of Code Checking for the less complex stages of evaluation and leaving the man responsible for evaluating those more complex, subjective and difficult to implement rules.

Keywords: Airport; Building Information Modeling; Code Checking; Conceptual Framework; Man-machine.

ملخص. تتناول هذه الورقة البحثية استخدامات BIM (معلومات البناء المجسمة) في التأكد من المعايير والتحقق التلقائي من دقة تصميم المطارات. حاليا في البرازيل يتم إجراء التقييم والموافقة علي تصميم المطارات من خلال INFRAERO (المؤسسة البرازيلية للبنية التحتية بالمواني الجوية) يدويا، مما ينتج عنه استغراق زمن اطول للتقييم وحدوث أخطاء. تم اقتراح آلية تلقائية لتقييم وفحص معايير ومفاهيم تصميم المطارات. والنظرية المستخدمة تعتمد علي أبحاث علوم التصميم، واقتراح استخدام الذكاء الاصطناعي. تظهر النتائج الجزئية ان الاندماج بين الانسان والذكاء الاصطناعي أكثر كفاءة في تقييم عملية تصميم المطارات في البرازيل، هذا الاندماج بين الانسان والذكاء الاصطناعي ينتج عنه نظام تقييم مزدوج، باستخدام نظام التحقق من المعايير للمراحل الأقل تعقيدا من عملية التقييم ويجعل الانسان مسؤولا عن تقييم المعايير الأكثر تعقيدا والأصعب من ناحية تنفيذها في النظام الآلي.

الكلمات المفتاحية. المطارات، معلومات البناء المجسمة، فحص أكواد البناء، الاطار المفاهيمي، الإنسان والآلة.

1. Introduction

Airport design (AD) by nature is complex, in view of the set of normative prerequisites that need to be met. In Brazil, the evaluation and approval of AD is carried out by INFRAERO (Brazilian federal public company responsible for the management of airports). In the current scenario, the design team, who develop the AD, submit the documentation design to the INFRAERO team of analysts in PDF files or printed. The analysis process is carried out in an analogical manner, with reading and interpretation of two-dimensional drawings. This evaluation process tends to be time consuming for the team of analysts. Moreover, it allows scope for ambiguities at the time of the evaluation, due to the different perspectives and specific knowledge of each analyst during the evaluation.

In response, this paper analyzes how the Building Information Modeling (BIM) combined with the use of Code Checking (CC) and validation (Succar, 2015). According to Eastman et al. (2009), CC is defined as a process of evaluating relationships or project attributes based on their object configurations. The use of the BIM Model for the CC can enable a new scenario for PAA analysts to automate the evaluation process, reducing the analysis time and increasing efficiency in relation to the traditional validation process (Santos and Andrade, 2020).

An example of rules tested and demonstrated by Guedes and Andrade (2019) is the rule that establishes the minimum circulation width between check-in lines and the PAA service desk. In this case, it was not only necessary to create a rule in a BIM assessment software, but it was also necessary that the authored BIM Model (architectural design model) that carries this information had been created on a BIM Platform and exported via IFC with the correct information, such as, Space Name (IfcSpace), Bouding Box Width (Ifc Space), as well as the specific parameters so that the analysis software could validate the rule correctly. What is important to note is that in the process of validating the quality of a project it is essential to consider not only the quality of the created rule, but also the quality of the created model, which must hang the model information following certain prescriptions, necessary for these recognized by the BIM evaluation software.

Another important factor in the CC is to understand the classes of rules that will be implemented. According to Solihin and Eastman (2015), the CC can be classified into 04 general classes: class 01 - rules that require a single or small number of explicit data; class 02 - rules that require simple values of derived attributes; class 03 - rules that require extended data structure; and, class 04 - rules that require a “proof of solution”. In the current process, analysts carry out the checking process manually, dedicating a lot of time to check the low complexity rules (usually classes 01 and 02), reducing the time to evaluate more complex design issues, related to the class 03 or 04 rules

On the other hand, the scenario proposed in this paper is to study and classify the rules (Class 01 to 04). For rules 01 and 02, it is proposed to automate, e.g.: check that all accessible toilets from the passenger terminal meet the accessibility criteria of NBR 9050. Rules 03 and 04, depending on the level of complexity, automation requires a long time, involving significant change in modeling and evaluation. For these, the use of semi-automated or manual evaluation is proposed. Thus, when studying and classifying the rules, it is possible to propose the automation of the rules that bring greater productivity gains in the evaluation of AD designs. Simpler rules with little effort to automate are automated. Complex rules, which require great effort to automate and little gain in productivity, remain evaluated manually. In this way, the complexity of the BIM model is reduced and the evaluation with code checking is simpler and more efficient.

2. Methods

The methodology used in this research is Design Science Research, which, according to March and Smith (1995), consists of two macros stages: (1) Construction, stage intended for the development of the artifact (in this paper is the evaluation method); and (2) Evaluation of the Artifact, stage destined the measurement of the efficiency of the artifact from the verification of its behavior in the analyzed context.

Stage (1) of Building the Artifact consisted of two phases. The first phase refers to the theoretical foundation on the topic. This phase started with a Systematic Literature Review (RSL). International and national publications on the subject have been identified in the past 10 years. Still in the first phase, case studies were carried out in the analysis and validation processes of airport projects in Brazil, together with INFRAERO, the Civil Aviation Secretariat (SAC) and companies specialized in the development of AD.

The second phase of step (1) consists of the design and development of the artifact. This phase started with the mapping of the AD evaluation guidelines established by Organs competent bodies. What has been observed is that although there are many guidelines, there are some that are most commonly reported as those that are least met and that generate notifications for correction. These are being classified and will be studied in more detail. It is these guidelines that make the greatest effort by the teams of analysts. Then, these guidelines are being transcribed into rules that are being implemented in BIM assessment software and tested in project situations. Among the various experiments carried out are the evaluation of good AD modeling practices and the evaluation of the efficiency in implementing each of these rules, based on the classification of the rules.

3. Proposition

The questions explained in this article and which are being investigated are: 1) which are the most important rules to be investigated and 2) what is the level of effort to implement each of these evaluation rules. To answer the first question, technical reports produced by INFRAERO and SAC analysts are being evaluated. These reports show which rules are least met by the AD and which lead to several cycles of change during the project's evaluation and review process. To answer the second question, the rules are being classified according to the rules classification proposed by Solihin and Eastman (2015) the class of rules (Class 01 to 04) and each of these are being studied in terms of level of complexity which is to implement each of these rules.

A simple rule, as shown in Figure 1 (Rule 01) is a class 2 rule. The condition for accepting this rule is: the minimum free area in an accessible toilet must be $\varnothing \geq 1.50$ m. To test this rule, Solibri Model Checker (SMC) was used. If the Model is compatible, SMC will show the graphic result representing a green circle on the floor (compatible), otherwise, the graphic result will be a red circle on the floor (not compatible). For this rule, the condition was not adequate, requiring a review of the project and resubmission for further evaluation. In this rule, for example, the entities IfcSpace and Classification Name would need to be present in the IFC, which is extremely simple information to hang in the model and easily filtered in the Model View Definition (MVD) to export the authorial BIM file in IFC format to the SMC, MVD Coordination View 2.0 was used

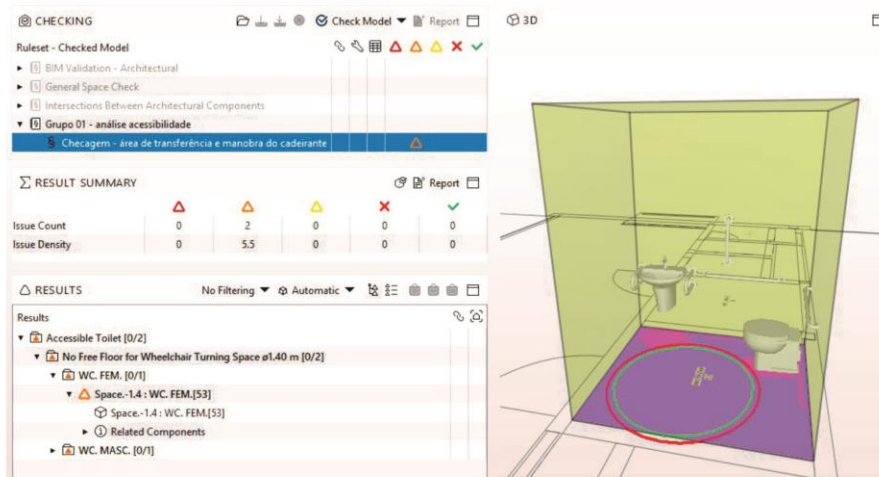

Figure 1. Automatic check of Rule 01 performed in SMC

Source: Elaborated by the authors (2020).

What was sought to investigate in the creation of this rule 01 was not only its functionality as the execution of the rule itself in the SMC, but also the overlapping of the groups of information and parameters used to create this rule in order to systematically analyze the reference documents, group to which the rule belongs, classification of the rule, IFC properties (necessary for creating the rule) and specific parameters of the SMC analysis software (necessary for creating rule 01). In this way, through the joint analysis of this information, it was possible to create an analysis table (see figure 02) in which it is possible to identify the systematic mapping of rule 01. Once all the rules are transposed to the analysis table, it will be possible to evaluate the effort made to create as much the BIM Model by the AD considering the minimum necessary and sufficient information for submission of an analysis process based on the CC, as well as the analysis framework will serve as a reference element so that the team of AD analysts can evaluate the effort required to be expended in creating a set of specific rules.

Analysis board - Rule 01																		
Doc. (ref.)	Description	Subject			Group			Classification [1]				IFC Properties			Analysis software (SMC)			
		Architecture	Structures	Infrastructure	Model Integrity	Accessibility	Space	Class 01	Class 02	Class 03	Class 04	ifcSpace	Classification Name			SOL 209 / 1.2		
01	Rule.01	X	-	-	-	X	-	-	X	-	-	X	X	-	-	X	-	-
-	-	-	-	-	-	-	-	-	-	-	-	-	-	-	-	-	-	

Informations (Rule 01)																
Description: transfer and maneuver areas for use of the toilet bowl (acesible bathroom)																
Condicion: minimum free area in an accessible toilet must be $\varnothing \geq 1.50$ m																

References																
DOC.01: ABNT NBR 9050/15 - Acessibilidade a edificações, mobiliário, espaços e equipamentos urbanos, Rio de Janeiro, Brasil (2015)																
[1]: Solihin, Eastman (2015)																
T.01: Rule Template 01 - Solibri Accessibility Rules (Solibri Model Checker)																

Figure 2. Analysis board (rule 01). Source: Elaborated by the authors (2020).

It is through this concept presented schematically in Figure 2 that this work seeks to bring up for discussion in this article. The focus is to identify which are the rules most commonly identified as not met in the manual evaluation (included in the Technical Monitoring Report - INFRAERO), of these, which are the rules that least efforts are undertaken for their evaluation with CC and for their insertion in the authoring BIM model. Those rules that require less effort, such as class 1 and 2 rules, are being prioritized. Class 3 and 4 rules are being studied to verify the level of complexity for its

MAN-MACHINE INTERACTION IN THE EVALUATION OF AIRPORT DESIGN PROCESS IN BRAZIL

implementation with CC and the level of difficulty to insert into an authoring and checking model using CC.

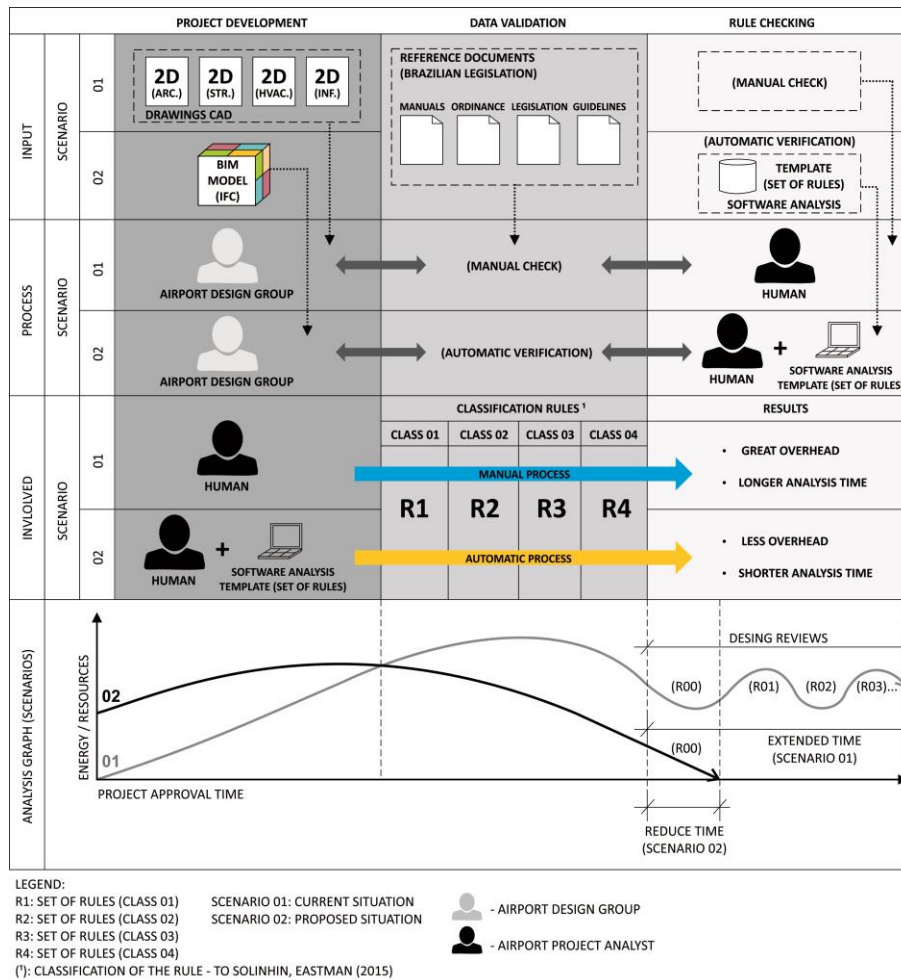

Figure 3. Synthesis table. Source: Elaborated by the authors (2020).

Figure 3 presented above represents a summary of the discussion covered in this article. The figure is divided into four parts. Each of the parties presents the analog evaluation process and the process proposed in this work. The first part of the figure corresponds to the inputs. In the proposed process, this step begins with the creation of the authoring model by the AD teams. After creating the models following the manuals prescribed by the evaluation team, this model goes through a stage of validating the consistency of the information. In this step, it is verified that the information is correctly hung in the IFC model, which were exported using the recommended MVD. If the information is consistent, go to the last step, which is automatic verification

using the evaluation software (in this case, the SMC). After this step, a report is generated indicating whether the project was approved or not.

The second part corresponds to the evaluation process. In the proposed scenario, manual (human) assessment is expected to occur to assess some more complex rules that are difficult to implement. And, automatic evaluation (machine) to evaluate those rules whose creation and evaluation effort are small compared to the level of time and productivity gain.

The third part studies the relationship between those involved and the type of rules class. Here are being evaluated which rules contribute the most to the reduction of analysis time, requiring less effort and consequently resources and time to implement. Class 1 and 2 rules are believed to be the ones that efforts should be focused on.

In the last part, the current scenario is compared with the proposed scenario, in terms of time for elaboration. In the proposed scenario, it is observed that some rules will remain evaluated manually, but several of the rules will be automated, reducing the project evaluation time without leaving the modeling and evaluation process with a level of complexity that could make it very difficult to implement.

5. Discussion

This research analyzed the structures of design processes (architectural and complementary) proposing the creation of an evaluation model that considers a man-machine interaction in the evaluation of airport design process in Brazil. CC-based assessment is already a reality in some countries such as the USA (GSA - General Services Administration), Singapore (CORELNET - Construction and Real Estate NETwork) and Norway (HITOS). However, in many situations the level of complexity for the formulation of authoring models or in the creation of rules for evaluating the model makes it difficult to consolidate a proposal based on this concept. With this proposal, it is expected that AD analysts will be able, through automatic rules verification, to automate much of the currently manual process, taking advantage of the time savings, increasing efficiency in the evaluation process, reducing efforts at the time of analysis, promoting a greater standardization of the analysis process, as well as minimizing the scope for ambiguity in the AD evaluation process, among other benefits related to the project approval phase. Throughout the development of this article, the potential of this approach was also observed to analyze other elements (not visible) considered in the development / analysis phase that belong to specific categories, such as, approach ramp, side transition ramp, among other elements that go beyond the limit of the airport site.

MAN-MACHINE INTERACTION IN THE EVALUATION OF AIRPORT DESIGN PROCESS IN BRAZIL

References

- ABNT. NBR 9050/15, 2015. Acessibilidade a edificações, mobiliário, espaços e equipamentos urbanos. Rio de Janeiro, Brasil.
- GUEDES, Ítalo; ANDRADE, Max., 2019. Automatic Rule-Based Checking for the Approval of Building Architectural Designs of Airport Passenger Terminals based on BIM. Proceedings of the 37th eCAADe and 23rd SIGraDi Conference - Volume 2, University of Porto, Porto, Portugal, pp. 333-338.
- SANTOS, Ítalo Guedes dos; ANDRADE, Max Lira Veras Xavier de; "Standardization of Airport Architectural Design Projects BIM-based for Code Checking", p. 490-498. In: Congresso SIGraDi 2020. São Paulo: Blucher, 2020.
- MARCH, S. T.; SMITH, G. F., 1995. Design and natural science research in Information Technology. Decision Support Systems, v.15, p- 251-266.
- NAWARI, O.N., Building information modeling: automated code checking and compliance processes. 1st edn. CRC Press, Boca Raton (2018).
- SACKS, R., EASTMAN, C., LEE, G., TEICHOLZ, P. BIM Handbook: A Guide to Building Information Modeling for Owners, Managers, Designers, Engineers, and Contractors. 3rd. edn. New Jersey: John Wiley & Sons (2018).
- SOLIHIM, W.; EASTMAN, C. Classification of rules for automated BIM rule checking development. Automation in Construction, 53, pp.69-82 (2015).
- SUPERINTENDÊNCIA DE EMPREENDIMENTOS DE ENGENHARIA - DEEP GERÊNCIA DE PLANEJAMENTO DE ENGENHARIA - EPPL., 2006. Manual de Critérios e Condicionantes de Planejamento Aeroportuário. Infraero.

USER-FRIENDLY TOOL TO ENABLE INDIVIDUAL HOMEOWNERS TO INVEST IN ENERGY EFFICIENCY

MOHAMMED SEDDIKI, AMAR BENNADJI, RICHARD LAING
*The Scott Sutherland School of Architecture and Built Environment,
Robert Gordon University,
Garthdee Road, Aberdeen, AB10 7GJ, United Kingdom
Email address: m.seddiki@rgu.ac.uk; a.bennadji@rgu.ac.uk;
r.laing@rgu.ac.uk*

AND

DAVID GRAY
*Cultural and Creative Business School, Robert Gordon University
Email address: david.gray@rgu.ac.uk*

Abstract. Buildings are an important source of CO₂ emissions and account for almost a third of final energy consumption globally. The necessity to achieve energy efficiency standards in new and existing buildings is now recognised. The residential sector consumes 25% of the global energy and is responsible of 17% of the global CO₂ emissions. EU governments have developed different support measures to decrease energy consumption in the residential sector. However, energy renovation by individual homeowners is lagging because the support measures do not take into account concerns of homeowners. This study is part of Sustainable housing for strong communities (Stronghouse) project, which aim to propose new tools and redesign support measures based on a better understanding of the drivers that motivate homeowners. This paper proposes a new user-friendly web-based multi-criteria decision-making tool that aims to empower homeowners to select the appropriate energy improvement method for their home fitting their criteria. The set of criteria that will be included in the application will be based on the preferences of residents obtained through questionnaires. A layered approach will be used to develop the proposed web application.

Keywords: *Decision support tool, multi-criteria decision-making, thermal renovation, homeowners*

USER-FRIENDLY TOOL TO ENABLE INDIVIDUAL HOMEOWNERS TO INVEST IN ENERGY EFFICIENCY

ملخص. تعد المباني مصدرًا مهمًا لانبعاثات غاز ثاني أكسيد الكربون وتمثل ما يقارب ثلث الاستهلاك النهائي للطاقة على مستوى العالم. إن تحقيق معايير الكفاءة الطاقوية في المباني الجديدة والموجودة أصبح ضرورة معترفًا بها. يمثل قطاع السكن 25٪ من إجمالي استهلاك الطاقة العالمية وهو مسؤول عن 17٪ من انبعاثات غاز ثاني أكسيد الكربون على مستوى العالم. لقد طورت حكومات الاتحاد الأوروبي العديد من وسائل الدعم للتقليل من كمية استهلاك الطاقة في قطاع السكن، وبالرغم من ذلك، فإن عمليات التجديد الطاقوي التي يقوم بها ملاك المساكن لا ترقى إلى المستوى المطلوب لأن وسائل الدعم لا تأخذ اهتماماتهم بعين الاعتبار. هذه الدراسة هي جزء من مشروع "سكن مستدام لمجتمعات قوية" والذي يهدف إلى اقتراح أدوات جديدة وإعادة تصميم تدابير الدعم بناءً على فهم أفضل للدوافع التي تحفز ملاك المساكن. تقترح هذه الورقة أداة صنع قرار جديدة، سهلة الاستخدام ومتعددة المعايير قائمة على شبكة الأنترنت والتي تهدف إلى تمكين ملاك المساكن من اختيار طريقة التحسين الطاقوي المناسبة لمنازلهم والتي تناسب معاييرهم. ستعتمد مجموعة المعايير التي سيتضمنها التطبيق على تفضيلات السكان التي تم الحصول عليها من خلال الاستبيانات. سيتم استخدام نهج متعدد الطبقات لتطوير تطبيق الأنترنت المقترح.

الكلمات المفتاحية: أداة دعم القرار، اتخاذ القرار متعدد المعايير، التجديد الحراري، ملاك المنازل.

1. Introduction

In Europe, buildings account for almost 40% of the energy consumption and 36% of CO2 emissions. According to the new version of the energy performance of buildings directive (2018/844/EU), European Union countries must establish strong long-term renovation strategies, aiming at decarbonising the national building stocks by 2050. Renovation of existing buildings could reduce the EU's CO2 emissions by about 5%. Current rates of energy renovation by individual homeowners are insufficient to achieve the necessary change in energy use (only about 1% of the building stock is renovated each year) (European-Commission, 2019).

Many scholars have indicated that non-adequacy of support measures represent a major hindrance to the adoption of energy renovation by individual homeowners and have emphasized that EU Member States should identify an adequate set of support measures by involving homeowners in the preparation and implementation of their strategies (Economidou et al., 2020). Other studies have considered the lack of methodological support in order to select the best thermal renovation solution as the main barrier that hinder the adoption of energy efficiency measures of homeowners (Seddiki and Bennadji, 2019).

There have been several projects that aimed to provide simple interfaces to assist homeowners in their renovation project (Lee et al., 2014). However, available tools mainly focus on carbon emissions, energy reduction and financial aspects. They do not take into consideration the fact that the selection of the best renovation solutions among a vast diversity of alternatives (thermal insulation, biomass, solar energy,) is a complex decision, which includes analysing different criteria (investment cost,

available grants, type of buildings, etc.), and engaging many stakeholders potentially, holding conflicting views.

Multiple-Criteria Decision Making (MCDM) analysis is a useful tool for these types of complex problems; it evaluates different solutions by taking into account several criteria and the opinions of various stakeholders. MCDM methods were widely applied for the thermal renovation of existing buildings. However, the majority of developed MCDM methods are not adapted to be used by homeowners due to their complexity.

The originality of this paper is to propose a new user-friendly web-based multi-criteria decision-making tool that aims to empower homeowners to select energy efficiency measures for their home fitting their criteria.

2. Literature review

As indicated in table 1, MCDM methods have been widely used for the thermal renovation of existing buildings. They were applied at an individual level (e.g. for the selection of the best insulation solution for a single building) and a neighbourhood level (e.g. for the selection of the best district heating system for a residential area). Moreover, the review of the literature indicates that the available MCDM methods require complex computations and are not adapted to be used by homeowners.

TABLE 1: Main works available in the literature concerning the application of MCDA methods in thermal renovation of buildings (adopted from Seddiki et al., (2018))

Authors	Fields of application	MCDA methods	Scales of application
(Medineckiene and Björk, 2011)	Thermal renovation of residential buildings	AHP,SAW,MEW, COPRAS	Individual level
(Zagorskas et al., 2014)	Selection of insulation option for historic buildings	TOPSIS	Individual level
(Zheng et al., 2009)	Building energy conservation	FAHP	Individual level
(Seddiki et al., 2016)	Thermal renovation of residential buildings	Delphi-Swing-PROMETHEE	Individual level
(Seddiki M, 2018)	Thermal renovation of residential buildings	FAHP-FPROMETHEE	Individual level
(Kontu et al., 2015)	Selection of heating system for residential buildings	SMAA	Neighbourhood level
(Lu et al., 2015)	The design optimization of the renewable energy system sizes in low/zero energy buildings.	Multi-objectives optimization using NSGA-II	Neighbourhood level

USER-FRIENDLY TOOL TO ENABLE INDIVIDUAL HOMEOWNERS TO INVEST IN ENERGY EFFICIENCY

(Catalina et al., 2011)	The selection of the best combination of renewable energy systems for residential buildings.	ELECTRE III	Neighbourhood level
(Seddiki et al. 2019)	Multi-criteria evaluation of renewable energy alternatives for electricity generation in residential buildings	FAHP-FPROMETHEE	Neighbourhood level
ELECTRE: Elimination and Choice Expressing the Reality; SMAA: Stochastic Multi-criteria Acceptability Analysis; AHP: Analytical Hierarchy Process; SAW: Simple Additive Weighting; MEW: Multiplicative Exponential Weighting; COPRAS: Complex Proportion Assessment; TOPSIS: Technique for Order of Preference by Similarity to Ideal Solution; FAHP; Fuzzy AHP			

3. Methodology

3.1. PHASE 1:

This phase aims to identify evaluation criteria and energy improvement solutions. It includes two main activities. The first activity aims to define a pre-screening list of criteria and renovation solutions; it will involve an in-depth data collection through literature review and face-to-face interviews with experts, stakeholders and decision-makers. Then, in the second activity, the preliminary set of criteria and renovation solution will be narrowed based on the preferences of residents obtained through questionnaires.

3.2. PHASE 2:

This phase aims to develop a new multi-criteria model. This phase will evaluate different multi-criteria methods and conclude which aspects are relevant to include in the proposed model.

3.3. PHASE 3:

This phase aims to develop a user-friendly web-based decision support tool. A layered approach will be used to develop the proposed system, which is comprised of three distinct but interconnected user interface, application and data layers:

- User interface layer, comprised of an individual interface and a group interface, incorporates a language module and a presentation module.
- Application layer hosts all the functional modules, which implement the proposed methodology in phase 02.
- Data layer stores all the necessary data for the decision problem.

The web application will provide a repository of available energy efficiency measures as well as a set of evaluation criteria (defined by a questionnaire in phase 1). The application will also provide default values of weighting criteria that could be easily modified to suit the homeowners' specific needs and preferences as indicated in Khelifi et al., (2006). From the homeowner's point of view, the proposed web application consists of several sequential steps as presented in figure 1.

First, the user of the application should provide information about the building (e.g. location, building type and form, energy consumption, current house conditions, etc.), then should define the energy performance target (e.g. local building regulations, EnerPHit renovation certification, etc.). After, the user should indicate the evaluation criteria and provide the importance of each criterion. Finally, the multi-criteria decision starts and the system recommendations are presented to the user. If the user is satisfied with the results, the process finishes here with recommendations. However, if the results are not satisfactory, a sensitivity analysis should be performed. Firstly, the importance of each criterion should be investigated. Secondly, the set of selected criteria should be examined. Finally, if the results are still not satisfactory, the energy performance target should be revised.

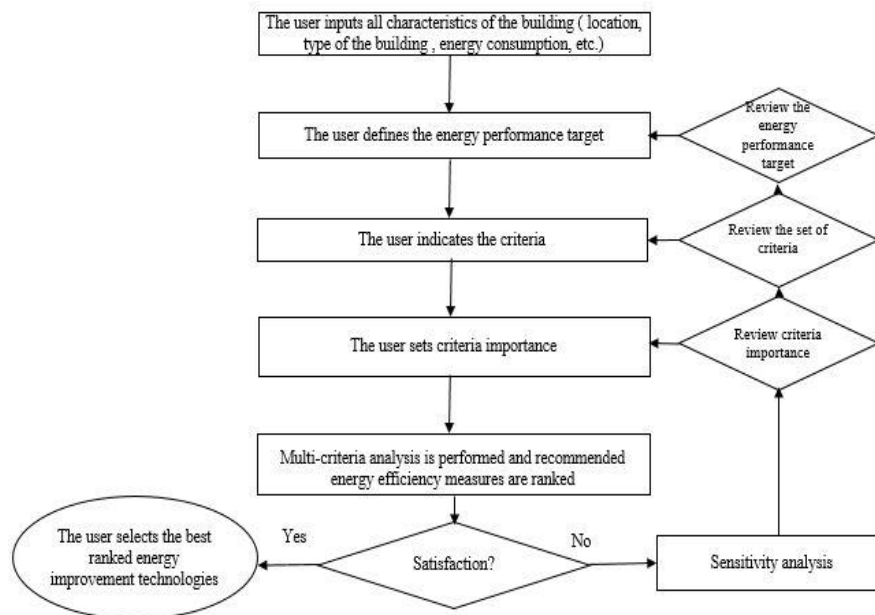

Figure 1. General algorithm of the proposed web application.

USER-FRIENDLY TOOL TO ENABLE INDIVIDUAL HOMEOWNERS TO INVEST IN ENERGY EFFICIENCY

4. Conclusion

Although EU governments have developed different supports measures to encourage homeowners to invest in energy efficiency, renovations rates are insufficient to achieve EU energy reduction targets. One of the main barriers that hinder homeowners from adopting energy efficiency measures is that available tools and supports measures do not take into consideration their criteria and preferences. Whereas multi-criteria decision methods allow to integrate preferences of residents in the renovation decision process, such methods are not adapted to be used by homeowners due to their complexity. The originality of this paper is to propose a new user-friendly web-based multi-criteria decision-making tool that aims to empower homeowners to select energy efficiency measures for their home fitting their criteria.

Acknowledgements

This paper is part of Stronghouse project, which is co-funded by European Regional Development Fund (ERDF) under the umbrella of Interreg North Sea Region. The 14 partners involved in the project are from Netherlands, Belgium, Germany, Denmark, Sweden and the United Kingdom.

References

- CATALINA, T., VIRGONE, J. & BLANCO, E. 2011. Multi-source energy systems analysis using a multi-criteria decision aid methodology. *Renewable Energy*, 36, 2245-2252.
- ECONOMIDOU, M., TODESCHI, V., BERTOLDI, P., D'AGOSTINO, D., ZANGHERI, P. & CASTELLAZZI, L. 2020. Review of 50 years of EU energy efficiency policies for buildings. *Energy and Buildings*, 225, 110322.
- EUROPEAN-COMMISSION. 2019. Energy performance of buildings directive [Online]. Available: https://ec.europa.eu/energy/topics/energy-efficiency/energy-efficient-buildings/energy-performance-buildings-directive_en.
- KHELIFI, O., LODOLO, A., VRANES, S., CENTI, G. & MIERTUS, S. 2006. A web-based decision support tool for groundwater remediation technologies selection. *Journal of Hydroinformatics*, 8, 91-100.
- KONTU, K., RINNE, S., OLKKONEN, V., LAHDELMA, R. & SALMINEN, P. 2015. Multicriteria evaluation of heating choices for a new sustainable residential area. *Energy and Buildings*, 93, 169-179.
- LEE, S. H., HONG, T. & PIETTE, M. A. 2014. Review of existing energy retrofit tools. Lawrence Berkeley National Lab.(LBNL), Berkeley, CA (United States).
- LU, Y., WANG, S., ZHAO, Y. & YAN, C. 2015. Renewable energy system optimization of low/zero energy buildings using single-objective and multi-objective optimization methods. *Energy and Buildings*, 89, 61-75.
- MEDINECKIENE, M. & BJÖRK, F. 2011. Owner preferences regarding renovation measures – the demonstration of using multi-criteria decision-making. *Journal of civil engineering and management*, 17, 284-295.

M. SEDDIKI, A. BENNADJI, R. LAING, D. GRAY

- SEDDIKI M, A. K., BENNADJI A 2018. Integrated FAHP-FPROMETHEE for thermal insulation of masonry buildings. *Facilities*, 36.
- SEDDIKI, M., ANOUCHE, K., BENNADJI, A. & BOATENG, P. 2016. A multi-criteria group decision-making method for the thermal renovation of masonry buildings: The case of Algeria. *Energy and Buildings*, 129, 471-483.
- SEDDIKI, M. & BENNADJI, A. 2019. Multi-criteria evaluation of renewable energy alternatives for electricity generation in a residential building. *Renewable and sustainable energy reviews*, 110, 101-117.
- ZAGORSKAS, J., ZAVADSKAS, E., TURSKIS, Z., BURINSKIENE, M., BLUMBERGA, A. & BLUMBERGA, D. 2014. Thermal insulation alternatives of historic brick buildings in Baltic Sea Region. *Energy and Buildings*, 78, 35-42.
- ZHENG, G., JING, Y., HUANG, H., ZHANG, X. & GAO, Y. 2009. Application of Life Cycle Assessment (LCA) and extenics theory for building energy conservation assessment. *Energy*, 34, 1870-1879.

AUTHOR INDEX

A

Abdalaty, Mai	341
Abdallah, Mohamed	622
Abdelmohsen, Sherif	142, 241, 264, 521, 622
Taouai, Abdelmounem	253
Abdennadher, Slim	114
Abdin, Ahmed	385
Abouhadid, Mariam	330
Afshar, Sepehr	306
Agkathidis, Asterios	214, 713
Alabbasi, Mohamed	214, 713
Alani, Mostafa	614
Albassel, Mohamed	7
Ali, Nouran	385
Al-Jokhadar, Amer	129
Al-Kaseem, Bilal	614
Allam, Samar	479
Al Maani, Duaa	129
Alnusairat, Saba	129
Alsaadani, Sara	142
Aly, Zeyad	264
Andrade, Max	201, 742

B

Bakir, Ramy	43, 142
Barakat, Ahmed	450
Başarır, Lale	23
Belkaid, Alia	603
Bennadji, Amar	750
Ben Saci, Abdelkader	603
Bernal, Marcelo	421, 661

C

Calvo, Francisco	661
Canestrino, Giuseppe	397
Cheddadi, Aqil	672
Chen, Han-Mei	214, 713
Cucuzzella, Carmela	177, 293

D

Daneshjoo, Khosro	32
Demir, Yüksel	551
Dorta, Tomas	253
Dounas, Theodoros	436

E

Efthimiou, Eftihis	536
Elbaz, Noran	371
El-Dabaa, Rana	241
El Dessuki, Reham	341
Elfiki, Sherif	43
ElGewely, Maha	114
Elgobashi, Aya	355
El Gohary, Maha	479
El Gohary, Soha	479
El Hussainy, Mariam	69
El Kassed, Ahmad	114
Elkhateeb, Samah	317
El Kordy, Ahmed	69
El Semary, Yasmeen	355
El-Shahat, Manal	317
Erol, Kutluhan	23
Eshagi, Sarvin	306
Ezzeldin, Mohamed	371

F

Fahmy, Marwa	646
Fathima, Linas	465
Fekry, Ahmed	341
Fereos, Pavlos	536
Fraschini, Matteo	494

G

Gabr, Mostafa	167
Georgiou, Michail	536
Georgiou, Odysseas	536
Gomez, Paula	421
Goubran, Sherif	177, 293
Gray, David	750
Guedes, Italo	742
Gül, Leman Figen	280
Gün, Ahmet	551

H

Hadi, Khatereh	421
Hannouch, Adam	592
Hassab, Ahmed	622
Hassoumi, Ines	603
Hazbei, Morteza	293

Heydari, Maziar	32
Hosny, Samir	385
Hossameldin, Hala	43
Hotta, Kensuke	672
Houda, Maryam	568

I

Ibrahim, Aly	264
Ikeda, Yasushi	672
Ishac, Mina	84

K

K, Chithra	465
Kemenova, Olga	421
Kia, Anoosha	227
Konstantinou, Andreas	190
Kontovourkis, Odysseas	190
Kyrizi, Nikos	190

L

Laing, Richard	750
----------------	-----

M

Mansour, Hussein	686
Marchal, Theo	156
Marey, Ahmed	450
Massoud, Passaint	521
Mekawy, Mohammed	167
Mayhoub, Mohammed	69
Mahdavinejad, Mohammadjavad	32, 227, 699
Mondal, Joy	407

N

Nadim, Wafaa	114
Najafi, Ali	99
Nizar, Firdous	293

O

Ouf, Mohamed	177
Özerol, Gizem	58

P

Pak, Burak	551
Pilechiha, Peiman	99, 699
Poustinchi, Ebrahim	636

R

Ramadan, Ayah	727
Raxworthy, Julian	494
Rodrigues, Isabella	201
Ronagh, Ehsan	227

S

Said, Noha	156
Salem, Islam	241
Samra, Medhat	686
Seddiki, Mohammed	750
Selçuk, Semra	58
Shams El-Din, Hend	581
Sheta, Sherif	686
Skates, Henry	699
Soulikias, Aristofanis	293
Swarts, Matthew	421

T

Talaat, Mostafa	114
Taşdelen, Sümeyye	280
Tziourrou, Panagiota	190

V

Valitabar, Mahdi	699
Varinlioglu, Güzden	306
Vegas, Gonzalo	661

W

Waly, Mustafa	7
---------------	---

Y

Yehia, Mohamed	114
Yönder, Veli	507

Z

Zamani, Erfan	436
---------------	-----



UNIVERSITY IN CAIRO



// 9th International Conference
// of the Arab Society for
// Computer Aided
// Architectural Design



<https://www.linkedin.com/company/ascaad>



<https://www.facebook.com/ascaad>