

FREEGAH, B., ASIM, T. and MISHRA, R. 2013. Computational fluid dynamics based analysis of a closed thermo-siphon hot water solar system. Presented at 26th Condition monitoring and diagnostic engineering management international congress 2013 (COMADEM 2013), 11-13 June 2013, Helsinki, Finland.

# Computational fluid dynamics based analysis of a closed thermo-siphon hot water solar system.

FREEGAH, B., ASIM, T. and MISHRA, R.

2013

---

# Computational Fluid Dynamics based Analysis of a Closed Thermo-Siphon Hot Water Solar System

\*B. Freegah, T. Asim, R. Mishra

School of Computing & Engineering, University of Huddersfield, Huddersfield, HD1 3DH, UK

\*Lecturer at Al-Mustansiriya University, Baghdad, Iraq

U1169570@hud.ac.uk

t.asim@hud.ac.uk

r.mishra@hud.ac.uk

## Keywords

Computation fluid dynamics (CFD), Thermo-siphon, natural convection, static temperature

## Abstract

One of the alternative sources of energy is solar energy which is available in abundance throughout the world. The energy contained within the solar rays is capable of starting natural convection within closed mechanical systems containing a suitable working fluid. One such system is commonly known as a Thermo-Siphon which transfers solar energy into internal energy of the working fluid, commonly water. In the present study, an attempt has been made towards better understanding of the flow structure within a thermo-siphon by analysing the natural convection phenomenon using Computational Fluid Dynamics techniques. A commercial CFD package has been used to create a virtual domain of the working fluid within the thermo-siphon, operating under no-load condition. The effects of the length to diameter ratio of the pipes connecting the condenser and the evaporator, number of connecting pipes, angle of inclination of the thermo-siphon and the heat flux from the solar rays to the working fluid, on the performance of the thermo-siphon, have been critically analysed in this study. The results depict that the heat flux and the length to diameter ratio of the pipes have significant effects on the performance of a thermo-siphon, whereas, the angle of inclination has negligibly small effect. Furthermore, an increase in the number of connecting pipes increases the temperature of the working fluid by absorbing more solar energy. Hence, CFD can be used as a tool to

analyse, design and optimise the performance output of a thermo-siphon with reasonable accuracy.

## 1. Introduction

In recent decades, the world has witnessed significant developments in the area of solar energy. Many researchers have been trying to fully understand the hydrodynamics of thermo-siphons in order to optimise the mechanical design of such systems. Most of these studies are based on experimental findings or theoretical analysis by using traditional methods.

Soinet. al. [1] studied the effect of insulation and the liquid level on the condenser performance and investigated the thermal performance of a thermo-siphon condenser containing boiling acetone and petroleum ether. The results have shown that the relationship between the condenser efficiency and liquid level is linear. Downing et. al.[2] has used R-11 and R-114 as working fluids inside solar condenser pipes. The results have shown that the working fluids, that have phase change, are more efficient and respond faster to heat transfer than working fluids that have single phase only. Fanney et. al. [3] conducted experimental study on solar domestic hot water system to analyse the effect of irradiance level on thermal performance of a refrigerant within the solar condenser. The results have shown that the effect of the irradiance level on thermal performance of refrigerant is negligibly small. Radhwan et. al. [4] conducted experimental studies on two integrated solar water heaters for

both forced and natural circulation water flows. R-11 was used as working fluid. The results show that the natural circulation water flow has a remarkable impact on the thermal performance while the forced circulation has relatively weaker impact. Esenet et. al.[5] experimentally studied three refrigerants, R-134, R-407 and R-410. The three systems have been tested under the same working conditions in an attempt to find out the most effective refrigerant among the three. The results have shown that R-410 as a working fluid is more efficient than other refrigerants for both the non-loading and loading operations. Shamanic et. al.[6] studied comparative performance of single-phase and two-phase closed loop thermo-siphons. R-134 has been used as the working fluid in two-phase thermo-siphon, whereas water has been used as the working fluid in single-phase thermo-siphon under same working conditions.

Recently, a few researchers have tried analysing the natural convection phenomenon using Computational Fluid Dynamics techniques. Asghar et. al. [7] carried out experimental studies to analyse the effects of fill ratio on performance of a thermo-siphon for three different heat fluxes and validated the results using CFD. The results have shown that the performance of a thermo-siphon gets affected significantly with fill ratio. Furthermore, it has been observed that CFD predicts the temperature profiles with reasonable accuracy. Numerical analysis of modified solar condenser has been investigated by Sato et.al. [8]. They conducted theoretical study in order to analyse the effect of heat pipe tilt angle and condenser geometry on temperature of the working fluid within the condenser by using computational Fluid Dynamics tools. The study shows that the tilt angle of 45° is optimal as far as the performance of the thermo-siphon is concerned. Subramanian et. al. [9] analysed the solar water heating system using both the CFD and the experimentation carried out in identical conditions for both uniform header and variable header systems. The solar water heater is designed with different diameters for the header. The results have shown that the overall thermal performance reduces due to non-uniform flow in riser tubes. Furthermore, the results depict that the overall thermal performance and efficiency is higher in variable header system due to uniform velocity. Iordanou et. al. [10] conducted CFD based study in order to investigate the effects of placing a metallic

mesh within the heat pipe of a passive solar condenser, and compared the results with a conventional passive solar condenser. The results have shown that the use of metal grid inside the heat pipe leads to increased solar condenser temperature.

In the present study, Computational Fluid Dynamics tools have been used to carry out an extensive study on the effects of various geometric parameters and the heat flux provided to the connecting pipes on the thermal performance of a closed loop solar hot water thermo-siphon system. The effect of these various parameters have not been explicitly analysed in the design process of thermo-siphons and hence this study is important for the design methodology.

## 2. Numerical Modelling

In order to analyse the performance of a thermo-siphon, a numerical model of the thermo-siphon has been created with varying geometrical parameters, whereas, the working fluid (water), diameter (0.025m) and thickness of connecting pipes (2mm) have been kept constant. Furthermore, a recirculating pipe, having the same diameter and thickness as that of the connecting pipes, has been included in the model in order to complete the closed loop for the thermo-siphon (figure 1). A commercial Computational Fluid Dynamic package has been used to simulate the flow within the thermo-siphon. The model makes use of the control volume numerical technique for solving the governing equations of mass and heat transfer.

It has been assumed that the thermo-siphon is in operation under no-load condition and hence only that part of the thermo-siphon has been modelled where the working fluid is present. The model consist of several inclined pipes connected at the top with the condenser and at the bottom with the evaporator, where the diameter of the condenser is five times the diameter of the connecting pipes and the diameter of the evaporator is the same as that of the connecting pipes. The condenser diameter has been chosen such that no recirculation of water takes place in the connecting pipes [7]. The model has been tested against various length to diameter ratios of connecting pipes ( $L/d = 50$  and  $100$ ) for different heat flux of  $250\text{W/m}^2$  and  $500\text{W/m}^2$  being

applied to the connecting pipes, simulating the effect of the solar rays on these pipes. The whole model is made inclined by  $30^\circ$  and  $60^\circ$  to clearly visualise the natural convection phenomena occurring in the thermo-siphon. In order to analyse the effect of the number of connecting pipes on the performance output of the thermo-siphon, three and five connecting pipes have been modelled separately in the thermo-siphon model.

It has been observed by Asggha et. al. [7] that the Boussinesq approach for the density of the working fluid in a thermo-siphon gives fairly accurate results and thus has been used in the present study. Three dimensional Navier-Stokes equations, in addition to the continuity and the energy equations have been numerically solved in an iterative manner to simulate the transient flow in the thermo-siphon for one hour.

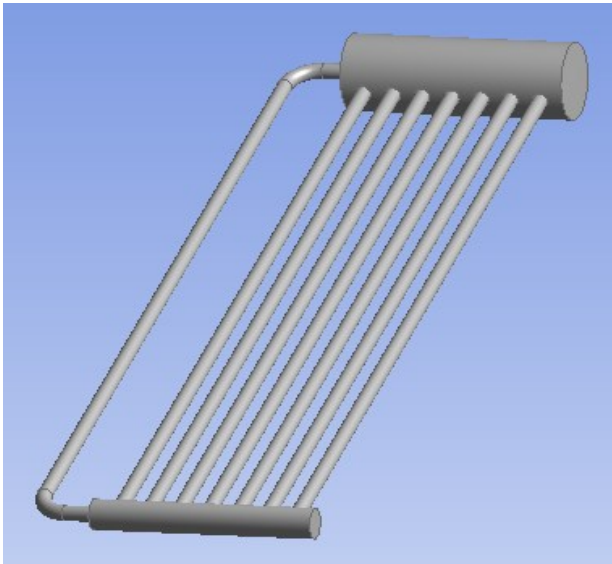

Figure 1 - The Geometry of the Thermo-Siphon Model

### 3. Results and Analysis

The numerical analysis carried out on the closed thermo-siphon hot water solar system clearly depicts the natural convection phenomena and the distribution of temperature, velocity and pressure of the working fluid within the model. Figure 2 depicts the velocity distribution within the central connecting pipe, the evaporator and the condenser for the thermo-siphon model consisting of three connecting pipes at an inclination angle of  $30^\circ$ . The natural convection phenomena can be clearly seen in the figure, i.e. as the working fluid gets heated, it expands due to increase in temperature and

volume (decrease in density). Due to the inclination of the connecting pipes, the working fluid propagates along the top wall of the pipe and enters the condenser. Furthermore, it can be seen that the velocity of the working fluid increases as it climbs up the pipe. This happens because more thermal energy is being absorbed by the fluid as it is propagating along the connecting pipe further decreasing its density. The working fluid attains highest velocity at the junction with the condenser.

Figure 3 further depicts the natural convection phenomena occurring in the thermo-siphon model considered in the present study. As mentioned earlier, the working fluid heats up and rises in the connecting pipe. Along the pipe, more thermal energy of the solar rays is transferred to the internal energy of the working fluid, increasing its temperature further. Highest temperature of the working fluid is observed at the junction of the connecting pipes and the condenser. Due to its lower density, the working fluid further rises within the condenser and gets accumulated along the top wall of the condenser.

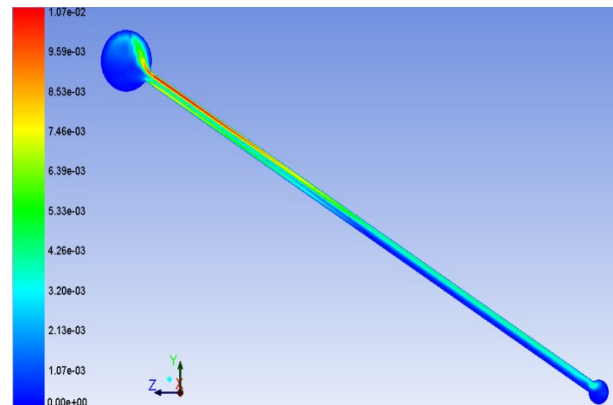

Figure 2 - Velocity variations in the working fluid in the thermo-siphon after 1 hour of operation at  $Q = 250W/m^2$  and  $\theta = 30^\circ$

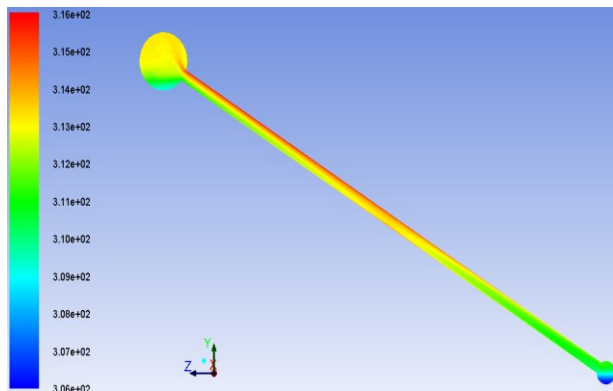

Figure 3 - Temperature variations in the working fluid in the thermo-siphon after 1 hour of operation at  $Q = 250W/m^2$  and  $\theta = 30^\circ$

Figure 4 depicts the temperature distribution within the condenser of the thermo-siphon. It can be clearly seen that the hot working fluid occupies the upper section of the condenser while the cold working fluid settles on the bottom of the condenser. The cold water is re-circulated to the evaporator through the recirculating pipe shown in figure 5. It can be seen that the temperature of the working fluid decreases as it propagates along the recirculating pipe. The motion of the working fluid in the recirculating pipe is dictated by the gravitational acceleration. It is worth mentioning at this point that although the recirculating pipe transfers the cold working fluid from the condenser to the evaporator, the working fluid is still at a higher temperature relative to the working fluid present in the evaporator. By comparing the temperature variations presented in figures 3 and 5, it can be clearly seen that the lowest temperature within the recirculating pipe is 311K whereas the lowest temperature of the working fluid within the evaporator is 300K, which has initially been taken as the operating temperature of the working fluid within the thermo-siphon model presented in this study.

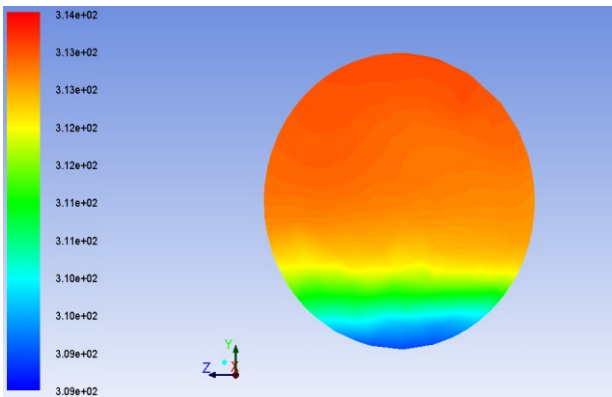

Figure 4 - Temperature variations in the condenser after 1 hour of operation at  $Q = 250W/m^2$  and  $\theta = 30^\circ$

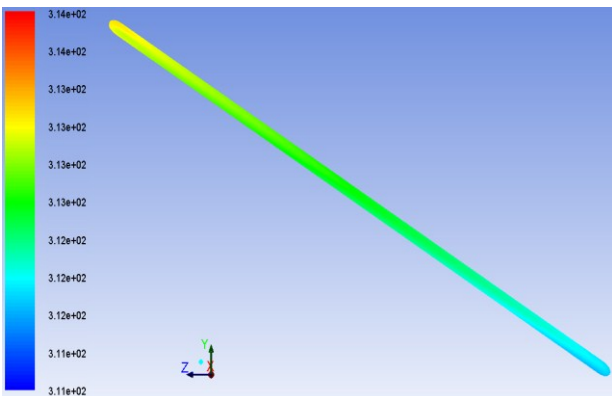

Figure 5. - Temperature variations in the recirculating pipe after 1 hour of operation at  $Q = 250W/m^2$  and  $\theta = 30^\circ$

It would be prudent at this point to present the mass balance in the thermo-siphon in order to analyze its performance. It is expected from a thermo-siphon system that no recirculation of the working fluid takes place in the connecting pipes, and that the working fluid recirculates only along the recirculating pipe. Figure 6 represents the mass balance in the connecting pipes and the recirculating pipe. It can be seen that the sum of the mass flow rates of the working fluid passing at any cross-section of the connecting pipes is equal to the mass flow rate of the working fluid through the cross section of the recirculating pipe. Hence, the mass is balanced in the thermo-siphon system considered in the present study.

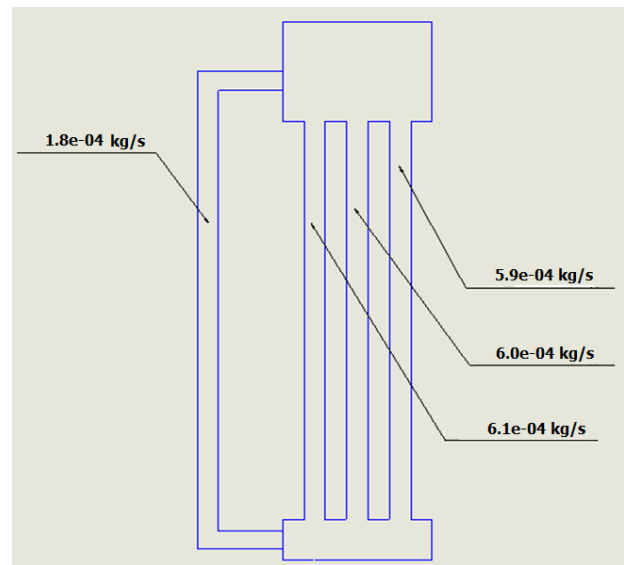

Figure 6 - Mass balance of the working fluid in the thermo-siphon model

Figure 7 depicts the variation in working fluid's temperature within the cross section of the condenser for variable number of the connecting pipes. It can be seen that the temperature within the condenser is higher for seven connecting pipes as compared to three connecting pipes. It is obvious from the fact that more number of connecting pipes transfers more hot fluid to the condenser. After one hour of operation, the difference in the condenser's temperature is 2K for both thermo-siphon configurations. Hence, increase in the number of connecting pipes increases the temperature of the working fluid within the condenser.

Figure 8 depicts the variation in working fluid's temperature within the cross section of the condenser for variable lengths of the connecting pipes. It can be seen that the temperature within the condenser is higher for  $L/d = 100$  as compared to  $L/d = 50$  of the connecting pipes. It is obvious from the fact that longer connecting pipes offers more surface area for the solar energy to be converted

into the working fluid's internal energy; hence increasing its temperature further. After one hour of operation, the difference in the condenser's temperature is 4K for both thermo-siphon configurations. Hence, increase in the length of the connecting pipes increases the temperature of the working fluid within the condenser.

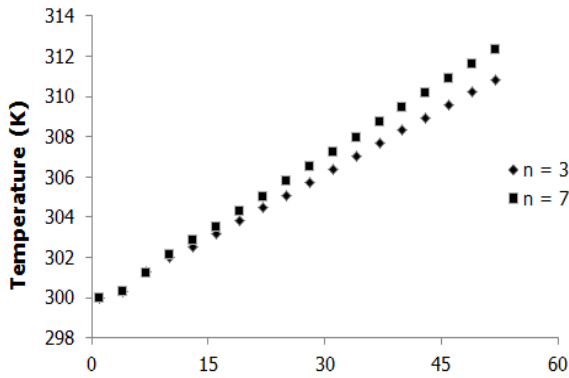

Figure 7 - Variations in temperature of the working fluid within the condenser for various  $n$  at  $L/d = 3$ ,  $Q = 250W/m^2$  and  $\theta = 30^\circ$

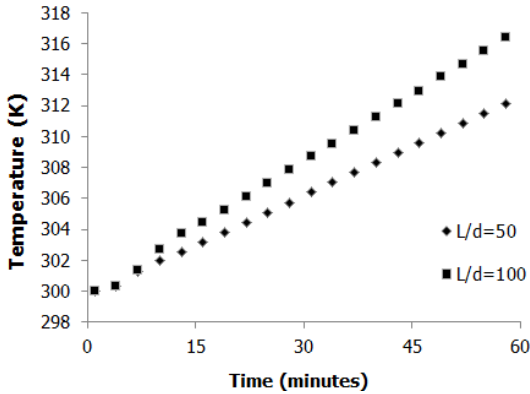

Figure 8 - Variations in temperature of the working fluid within the condenser for various  $L/d$  at  $n = 3$ ,  $Q = 250W/m^2$  and  $\theta = 30^\circ$

Figure 9 depicts the variation in working fluid's temperature within the cross section of the condenser for variable amount of heat flux provided to the connecting pipes. It can be seen that the temperature within the condenser is considerably higher for heat flux of  $500W/m^2$  as compared to heat flux of  $250W/m^2$ . It is obvious from the fact that more heat flux provided to the connecting pipes heats up the working fluid further. After one hour of operation, the difference in the condenser's temperature is 11K. Hence, increase in the heat flux provided to the connecting pipes increases the temperature of the working fluid within the

condenser.

Figure 10 depicts the variation in working fluid's temperature within the cross section of the condenser for variable inclination angles of the thermo-siphon. It can be seen that the temperature within the condenser is negligibly higher (less than 0.1%) for  $\theta = 60^\circ$  as compared to  $\theta = 30^\circ$ . Hence, increase in the inclination angle of the thermo-siphon has negligibly small effect on the temperature of the working fluid within the condenser.

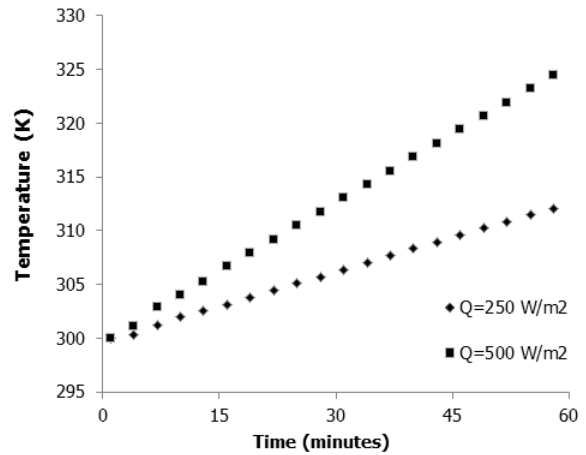

Figure 9 - Variations in temperature of the working fluid within the condenser for various heat fluxes at  $n = 3$ ,  $L/d = 50$  and  $\theta = 30^\circ$

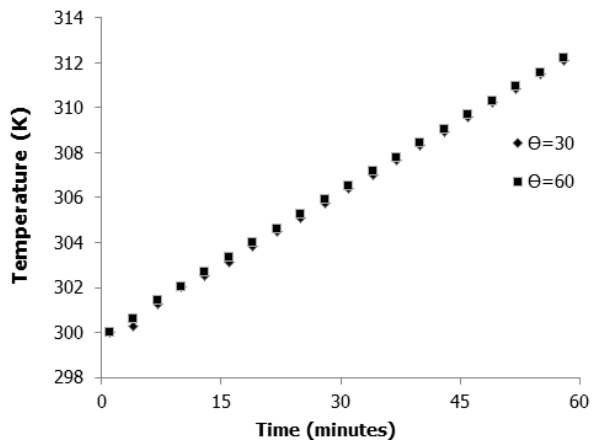

Figure 10 - Variations in temperature of the working fluid within the condenser for various inclination angles at  $n = 3$ ,  $Q = 250W/m^2$  and  $L/d = 50$

#### 4. Conclusions

The effects of various parameters, such as number of connecting pipes,  $L/d$  ratios of the connecting pipes, heat flux provided to the connecting pipes and the angle of inclination of the thermo-siphon have been numerically analyzed and it can be concluded that the effect of the heat flux dominates the performance of the thermo-siphon. The number

and L/d ratios of the connecting pipes also tend to affect the temperature of the working fluid within the condenser of the thermo-siphon, whereas, the angle of inclination of the thermo-siphon has negligibly small effect on the performance of a thermo-siphon. The information provided in this study can be used to design the thermo-siphon systems optimally. Furthermore, it can be concluded that Computational Fluid Dynamics can be used as an effective tool to analyze the performance of a thermo-siphon with reasonable accuracy.

## 5. References

- [1] R. S. Soin, K. S. Rao and D. P. Rao (1979) "Performance of flat plate solar condenser with fluid undergoing phase change" *Solar Energy*, vol: 23, pp: 69 – 73
- [2] R. C. Downing and V. W. Walden (1980) "Phase-change heat transfer in solar hot water heating system using R-11 and R-114", *ASHRAE Trans.*, vol: 86
- [3] A. H. Fanney and C. P. Terlizzi (1985) "Testing of refrigerant-charged solar domestic hot water systems", *Solar Energy*, vol: 35, No.4, pp: 353 – 366
- [4] A. M. Radhwan, G. M. Zaki and A. Jamil (1990) "Refrigerant-charged integrated solar water heater", *Energy Research*, vol: 14, pp: 421 – 432
- [5] E. Mehmet and E. Hikmet (2005) "Experimental investigation of a two-phase closed thermosyphon solar water heater" *Solar Energy*, vol: 79, pp: 459 – 468
- [6] A. Samanci and A. Berber (2011) "Experimental investigation of single-phase and two-phase closed thermo-syphon solar water heater systems" *Scientific Research and Essays*, vol: 6, pp: 688 – 693
- [7] A. A. Dehdakhel, M. Rahimi and A. A. Alsairafi (2010) "CFD modeling of flow and heat transfer in a thermo-syphon" *International Communications in Heat and Mass Transfer*, vol: 37, pp: 312 – 318
- [8] A. I. Sato, V. L. Scalon and A. Padilha (2012) "Numerical analysis of a modified evacuated tubes solar condenser" *International Conference on Renewable Energies and Power Quality*, 28 – 30 March, Spain
- [9] J. Subramanian, S. Kumar T. Kozhndu, and T. Selvam (2012) "Experimental Studies on Variable Header Solar Water Heating System" 2<sup>nd</sup>

*International Conference on Mechanical, Production and Automobile Engineering*, 28 – 29 April, Singapore

- [10] G. Iordanou and G. Tsirigotis (2012) "Computational Fluid Dynamics (CFD) Investigations of the Effect of Placing a Metallic Mesh in the Channels of a Passive Solar Condenser Model" *Electronics & Electrical Engineering*, issue: 121, pp: 69