



**ROBERT GORDON
UNIVERSITY • ABERDEEN**

OpenAIR@RGU

The Open Access Institutional Repository at Robert Gordon University

<http://openair.rgu.ac.uk>

This is an author produced version of a paper published in

ASHRAE Transactions (ISSN 0001-2505)

This version may not include final proof corrections and does not include published layout or pagination.

Citation Details

Citation for the version of the work held in 'OpenAIR@RGU':

TAYLOR, B. J. and IMBABI, M. S., 2000. Environmental design using dynamic insulation. Available from *OpenAIR@RGU*. [online]. Available from: <http://openair.rgu.ac.uk>

Citation for the publisher's version:

TAYLOR, B. J. and IMBABI, M. S., 2000. Environmental design using dynamic insulation. *ASHRAE Transactions*, 106(1), pp. 15-26.

Copyright

Items in 'OpenAIR@RGU', Robert Gordon University Open Access Institutional Repository, are protected by copyright and intellectual property law. If you believe that any material held in 'OpenAIR@RGU' infringes copyright, please contact openair-help@rgu.ac.uk with details. The item will be removed from the repository while the claim is investigated.

Copyright ©2000, American Society of Heating, Refrigerating and Air-Conditioning Engineers, Inc. ASHRAE Transactions, 106 Part 1. "Posted by permission. Further distribution prohibited without permission of ASHRAE (www.ashrae.org/permissions).

Environmental Design Using Dynamic Insulation

Bruce J. Taylor, C.Eng.

Mohammed S. Imbabi, Ph.D.

ABSTRACT

In conventional airtight buildings, the architect has considerable freedom to decide how much the external environment will influence the internal heating, cooling, and ventilation loads. The services engineer provides the plant and equipment required to deal with these loads. This division of labor could lead to undesirable consequences in the case of dynamic insulation, a form of air permeable construction where bulk air flow "through" the building envelope may be used to either enhance or restrict the conductive heat and mass diffusion fluxes. Small changes in temperature (indoor and out) and wind speed and direction will influence the behavior of a dynamically insulated envelope since the internal and external environments are much more intimately coupled. Buildings employing dynamic insulation thus require good environmental design principles to be applied. The objective of this paper is to lay down rigorous principles that will form the basis of guidelines to architects and building services engineers on how to take account of the ever changing external environment when designing durable and comfortable buildings employing dynamic insulation.

INTRODUCTION

Greater physical insight into dynamic insulation and a clearer appreciation of its limitations and potential for reducing energy consumption in buildings and improving indoor air quality have been gained in recent years (Taylor and Imbabi 1996, 1997; Taylor et al. 1996, 1997). In essence, dynamic insulation works by permitting the bulk air flow through the building fabric in such a way as to either enhance or restrict the

conductive heat and mass diffusion fluxes depending on the internal climate desired.

There is a current trend in building design to pay more attention to the internal and external environments in order to minimize energy expenditure on lighting, heating, and cooling. With conventional airtight building envelopes, the architect has much greater control over how much the external environment influences the internal heating and cooling loads and the required ventilation. Once the architect has completed the design, he or she can then bring in the building services engineer to provide the plant and equipment to deal with these loads. This caricature of the design process often happens in reality and the results are frequently mediocre. The best designs are produced when clients, architects, and building services engineers are able to work closely together on a project.

While this division of responsibilities between the parties can produce tolerable buildings, when the envelope is airtight, the results will be disastrous if air permeable envelopes are being contemplated. With airtight envelopes the environmental design approach is only an option; however, with air permeable envelopes, it is imperative that good environmental design principles be applied. The mere fact that dynamic insulation relies on outdoor air flowing through the wall to the inside means that the internal and external environments are intimately coupled. Changes in temperature, indoors or out, and changes in wind speed and direction will influence the behavior of a dynamically insulated wall and must be taken into account in the design. In this paper, we seek to develop the basic principles that should, in time, enable architects and building services engineers to take account of the ever-chang-

Bruce J. Taylor is a research associate in the Scott Sutherland School of Architecture at Robert Gordon University, Aberdeen, Scotland. **Mohammed S. Imbabi** is a lecturer in the Department of Engineering, Kings College at the University of Aberdeen.

ing external environment when designing durable and comfortable buildings that employ dynamic insulation.

AIR PERMEABILITY AND ITS MEASUREMENT

In order to design wall elements that will permit the required air flows, the air permeability of materials needs to be known. Since this is a relatively new way of using building materials, their air permeability is not yet part of the standard data provided by manufacturers or available in the literature. The permeability of a material to air (Φ) is defined as the volume of air that is forced through a 1 m cube of material in one hour by a pressure difference of 1 Pa:

$$\Phi = \frac{LQ}{A\Delta P} \quad (1)$$

From its definition, the permeability is a property of the material. It is useful in enabling the permeance (ϕ) of a component of a given thickness to be calculated:

$$\phi = \frac{Q}{A\Delta P} = \frac{\Phi}{L} \quad (2)$$

The air permeability is measured by blowing air through a sample of the material of known size and measuring the pressure drop across it (see Figure 1). The technique and instruments used vary according to the permeability of the material. For permeable materials, such as fiberboard or cellulose, a fan is used to draw air through a sample of the material, and an orifice plate measures the air flow rate. In our tests, such samples were contained in a 0.6 m square box to represent part of a wall section, and no special measures were taken to seal around the edges. This would lead to slight

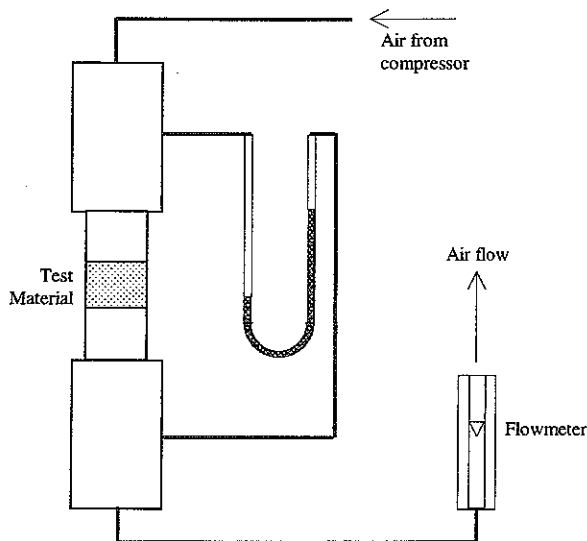

Figure 1 Apparatus for measuring air permeability.

overestimation of permeability of a 0.6 m wide \times 2.4 m high wall section. For impermeable materials, such as plasterboard or concrete block, a small sample of the material is sealed in a 22 mm diameter tube and air from a compressor is blown through it. On account of both the sample size and low permeability, the air flow rates are extremely small and have to be measured by a rotameter or bubble meter.

In practice, rather than take just one set of readings, the experiment is repeated at different flow rates. From the above equations it can be seen that if the permeability is a constant, the air flow rate will vary linearly with pressure difference. This turns out to be the case for most building materials over the range of pressure differences that arise in buildings.

AIR PERMEABILITY DATA AND APPLICATION

The results of experimental tests on a variety of materials are summarized in Appendix A, Table A1. These have been extended to include other materials using data obtained by Bartussek (1989) as shown in Appendix A, Table A2. In order to illustrate the applications of these data, consider the materials used in a dynamically insulated dwelling at Newton Dee: fiberboard, cellulose, and Hereklith board. The cellulose, despite its superficial appearance, has a permeance 20 times greater than that of 12 mm sheet fiberboard.

The linear relationship between the flow and pressure drop for air permeable building materials means that the overall permeability of a composite construction is easily calculated. Consider n layers, each of permeance ϕ_i held tightly together so that there is no leakage along the interfaces between the materials. Since the air flow rate is the same through each layer and the total pressure drop is the sum of the pressure drops across each layer it follows that

$$\frac{A \Delta p_t}{Q} = \sum_{i=1}^n \frac{A \Delta p_i}{Q} \quad (3)$$

From the definition of permeance this is simply

$$\frac{1}{\phi_t} = \sum_{i=1}^n \frac{1}{\phi_i} \quad (4)$$

From the data in Appendix A, Table A1, the fiberboard contributes 93% of the resistance to air flow through the wall in a house and is thus the material that controls the flow of air through the wall. Having such an air control layer has advantages:

- It simplifies the design process since the pressure drop across the Hereklith board and cellulose insulation may be neglected.
- Variations in the density and also in the permeability of the insulation do not affect the air flow through the wall. This is more important for a material such as cellulose than for rockwool, for example, which will have a more uniform density.

Because of the crucial importance of the fiberboard in controlling airflow, tests were carried out to see how joining

the panels together would change permeability. The permeability of a fiberboard sheet was measured before and after cutting it in two and carefully matching the cut edges of the two halves together. No jointing or sealing materials were used. For this dry joint, the permeance of the fiberboard sheet increased from 1.160 to 1.189 m³/m²hPa or 2.5%. On this basis it might appear not to be necessary for the fiberboard panel joints to be sealed and that a visual inspection of the joints would be sufficient to determine if any remedial sealing needed to be carried out. However, this would not take account of movement of the boards under fluctuating wind loads, temperature, and humidity. It is probably safer to seal the joints in a way that will accommodate relative movement under varying loads.

As might be expected, plasterboard and thermal block are, for most practical purposes, impermeable to air. It is anticipated that foil-backed plasterboard, which was not measured, would have an even lower permeability. The lightweight concrete block, made with a porous aggregate, turns out to have a higher permeability than fiberboard. This opens up the possibility of designing porous masonry walls that will have much higher thermal capacity than timber-framed walls (Taylor et al. 1997).

In a dynamically insulated building, the air must flow in through the air permeable walls rather than through construction joints, penetrations through walls, around doors and windows, etc. This adventitious air infiltration must be kept to a minimum and requires careful design of construction details and close supervision during construction.

How to determine the design airtightness required for a dynamically insulated building to function effectively with an envelope of a given air permeance is shown in Appendix B. A numerical example shows that a dynamically insulated envelope would work in a house built to the very high standards of the Canadian R2000 homes.

APPLICATION TO DYNAMIC INSULATION

Dynamic insulation in cold climates should ideally be used with air flowing *into* the building at all points of the permeable envelope. An outward flow of air would increase the heat loss and the risk of condensation within the wall. In a climate that permitted all the interstitial condensation that occurred during the heating season to evaporate during summer, the inherent problems of mold growth and decay may not arise. However, for safety, the first requirement is to provide adequate depressurization of the building to ensure that the effects of average wind speed and internal temperature gradients (stack effect) are overcome.

Stack Effect

A volume of fluid that has a lower density than the surrounding fluid will tend to rise in a gravitational field because of buoyancy forces. In the context of buildings, the temperature difference between the inside and outside air leads to a difference in density between the air outside and

inside the building. This will lead to an exchange of air across any openings, such as doors, windows, and chimneys, in the building.

When the inside air temperature is greater than outside, the cooler outside air will flow into the building through openings in the lower part of the building and warm air escapes through openings at a higher level. The height at which the transition between inflow and outflow occurs is the neutral pressure level (NPL). The elevation of the NPL depends only on the relative size of the openings in the envelope, their resistance to flow, and their vertical placement in the envelope. It does not depend on the difference in temperature between inside and out except in the case of air permeable envelopes, as will be shown.

Theory for Natural Convection Across a Permeable Envelope. Calculation of the elevation of the NPL in buildings with openings was developed by Bruce (1978). While his results are not directly applicable to a building where the entire or substantial portions of the envelope are air permeable, the theory he developed can be adapted to the case of air permeable envelopes. The reason why conventional natural ventilation theory, developed for buildings with openings such as windows in houses or space boarding in the side of cattle sheds, does not apply in dynamically insulated buildings is that the pressure-flow relationships are different.

Flow through such openings follows an orifice-type relationship:

$$Q = C \Delta p^n \quad (5)$$

where the exponent is 0.5 for large openings such as windows and doors and 0.6 when considering the narrow gaps around such features when they are closed. With dynamic insulation, the flow is Darcean (laminar) due to the very low air velocities and the relatively small size of the pores. This has been verified experimentally. Thus, for air permeable envelopes the exponent $n = 1$.

Envelope without Any Discrete Openings. Here the term "discrete opening" is used in the general sense to denote openings, such as doors and windows, and any other area(s) of the envelope where the air permeance is different from the major part of the envelope.

Figure 2 shows a portion of an air permeable envelope at angle θ to the horizontal. Since we are concerned with calculating the elevation of the NPL where an estimate to within 0.1 m is adequate, which also coincides with the order of magnitude of the insulation thickness, it is appropriate for this model to treat the envelope as a thin membrane. At this level of approximation, we can simply regard the air as flowing horizontally through the insulation, driven by the difference in pressure between inside and out.

Applying Bernoulli's equation across the wall between points 1 and 2 on a horizontal streamline (Figure 2):

$$p_1 + g\rho_1(\bar{h} - h) + \frac{1}{2}\rho_1 v_1^2 = p_2 + g\rho_2(\bar{h} - h) + \frac{1}{2}\rho_1 v_2^2 + \Delta p_{loss} \quad (6)$$

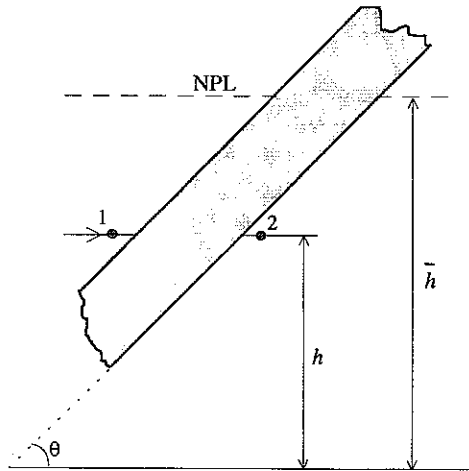

Figure 2 Application of Bernoulli's equation to porous wall.

The overall air permeance of the wall is chosen so that for pressure differences of the order of 10 Pa, the velocities through the wall are typically between 1 and 10 m/h. At these low velocities the kinetic energy terms are insignificant. The pressure loss term accounts for the energy dissipated within the porous media, corresponding to the Darcy flow relationship:

$$\Delta p_{loss} = \frac{v}{\phi_t} \quad (7)$$

where ϕ_t is the overall permeance of the wall. It is the insignificance of the kinetic energy terms compared with the pressure loss term that distinguishes natural ventilation through air permeable walls from flow through more conventional openings. The height h measured from ground level has, in Equation 6, been referenced to the NPL at height \bar{h} , which is the objective of our calculation. By means of a fan or roof ventilator, the interior of the building is at pressure p_2 and the atmospheric pressure is p_1 . With these approximations and assumptions the energy equation reduces to

$$p_1 - p_2 + g(\rho_1 - \rho_2)(\bar{h} - h) = \frac{v}{\phi_t} \quad (8)$$

By treating air as a perfect gas it is readily shown that

$$\rho_1 - \rho_2 = \rho_1 \left(\frac{\Delta T}{T_2} \right) \quad (9)$$

At ambient temperature and pressure this evaluates to

$$\rho_1 - \rho_2 = 0.043(T_2 - T_1) \quad (10)$$

Over the whole building envelope, there will be no net flow of air:

$$\int_A v \, dA = 0 \quad (11)$$

For the purposes of locating the elevation of the NPL for stack pressure alone, the pressure difference in Equation 8 can be omitted and the above integral becomes

$$g \Delta \rho \int_A \phi_t(h)(\bar{h} - h) \, dA = 0 \quad (12)$$

This is the general equation for calculating the elevation of the NPL in an air permeable wall where the permeance of the wall varies with height. In practice, while there will be local variations in permeance of a wall due to the inherent variability of materials and the presence of structural frames, etc., the permeance may be treated as being a constant over areas of the order 1 m² for a particular wall construction. In this case, the equation for calculating the NPL is simply

$$\int_A (\bar{h} - h) \, dA = 0 \quad (13)$$

The NPL will be raised or lowered from the elevation calculated above if the building is depressurized or pressurized, respectively, by a fan.

The total flow rate inwards through the wall generated by stack effect is

$$Q_{in} = g \Delta \rho \phi_t \int_{A(\bar{h})} (\bar{h} - h) \, dh \quad (14)$$

where $A(\bar{h})$ indicates that the integral is evaluated from ground level up to the NPL. Q_{in} will also equal the flow of air out through the envelope.

Envelope with Discrete Openings. When the envelope comprises both permeable elements and discrete openings, the above theory needs to be extended to include the work of Bruce (1978). The following equation from Bruce for the velocity at height h through an arbitrary opening is presented without derivation:

$$v_d = \frac{|\bar{h} - h|}{\bar{h} - h} \left[2g \frac{\Delta \rho}{\rho} |\bar{h} - h| \right]^{1/2} \quad (15)$$

Consider a building with air permeable walls of area A_p and an impermeable pitched roof with a ridge ventilator (see Figure 3). There will be no net flow over the envelope and so the mass continuity equation is

$$\int_{A_p} v_p \, dA_p + C \int_{A_d} v_d \, dA_d = 0 \quad (16)$$

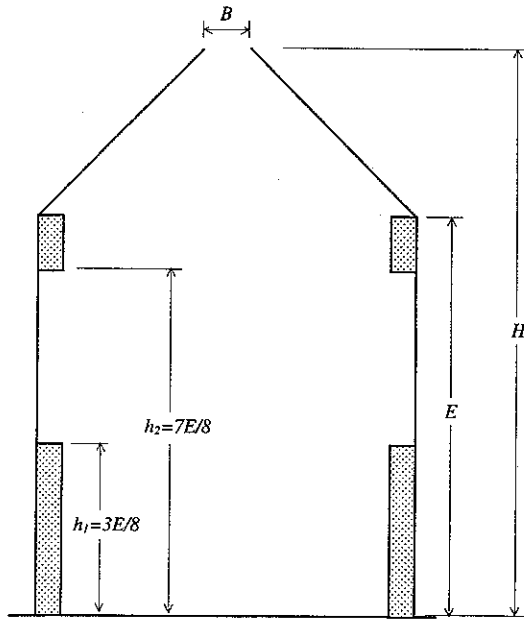

Figure 3 Building with permeable walls and open ridge.

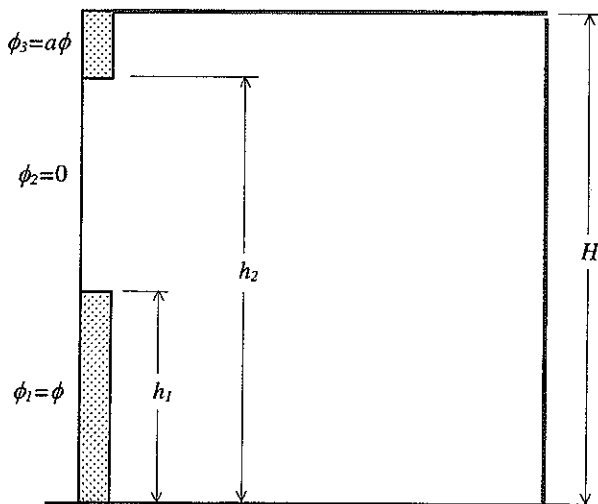

Figure 4 Envelope without discrete openings.

The discharge coefficient for the ridge opening is defined, as usual, by

$$C = \frac{Q}{A_d \bar{v}} \quad (17)$$

where \bar{v} is the average air velocity through the ridge opening. Using Equations 8 and 15, the mass continuity equation becomes

$$\phi_1 g \Delta \rho \int_{A_p} (\bar{h} - h) dA_p + C \left(2g \frac{\Delta \rho}{\rho} \right)^{1/2} \int_{A_d} \frac{|\bar{h} - h|^{3/2}}{\bar{h} - h} dA_d = 0 \quad (18)$$

This is the general equation for the elevation of the NPL, \bar{h} .

Note that it retains the environmental conditions so that the height of the NPL is no longer a function of the size and position of the openings alone.

Example 1: envelope without any discrete openings. To illustrate the evaluation of Equations 12 and 14, consider the example of an air permeable wall of width W in a flat roofed construction (Figure 4). A discrete impermeable element, a sealed window running the full width of the wall, is included. In dynamic insulation construction, it is important that the air flows only through the permeable wall and not through gaps around doors and windows and between the insulation and timber framing. It is assumed for the sake of generality that the wall above the window is of a different permeance than the one below. For this case Equation 12 changes to

$$\int_A \phi_1(h) (\bar{h} - h) dA = \phi_1 W \int_0^{h_1} (\bar{h} - h) dh + \phi_2 W a \int_{h_2}^H (\bar{h} - h) dh = 0 \quad (19)$$

where a is the ratio of the permeances of the upper and lower parts of the wall, as shown in Figure 4. Integrating and solving for the NPL, \bar{h} , gives

$$\frac{\bar{h}}{H} = \frac{\left(\frac{h_1}{H} \right)^2 + a \left(1 - \left(\frac{h_2}{H} \right)^2 \right)}{2 \left(\frac{h_1}{H} + a \left(1 - \frac{h_2}{H} \right) \right)} \quad (20)$$

It is helpful to consider numerical examples of this very useful equation to reinforce the physical insight it provides into the design of air permeable envelopes:

- (i) With 50% glazing, $h_1/H = 3/8$, $h_2/H = 7/8$, and $a = 1$, then the NPL coincides with the window-sill at $\bar{h}/H = 3/8$ (Figure 5a).
- (ii) As above, but with $a = 2$, the NPL is raised from the windowsill to just below the midpoint of the wall at $\bar{h}/H = 39/80$ (Figure 5b).

This illustrates how the NPL can be adjusted by varying the size, disposition, and permeability of the envelope elements.

Example (ii) above can be used to illustrate how to calculate the airflow through the wall. Applying Equation 14,

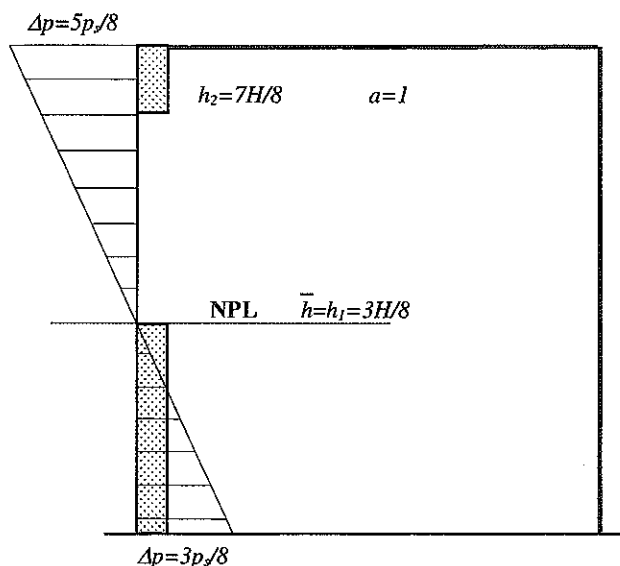

(a) Uniform permeance above and below the window.

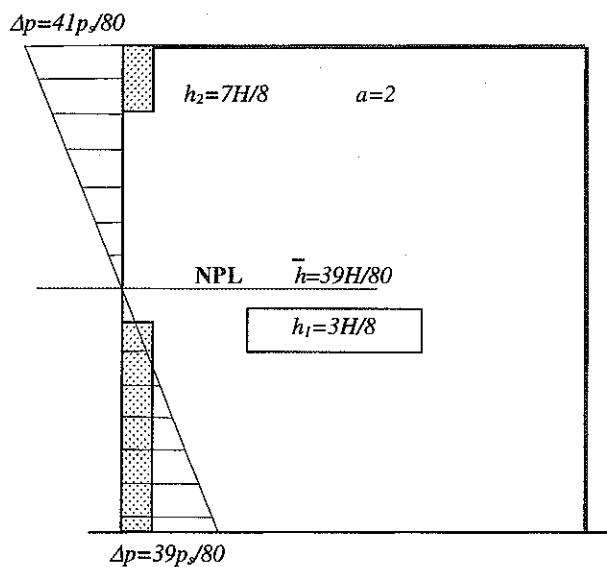

(b) Permeance of wall above the window at twice that of the permeance below.

Figure 5 Examples of envelope without discrete openings.

$$Q_{in} = W\phi_i g \Delta p \int_0^{\bar{h}} (\bar{h} - h) dh = W\phi_i g \Delta p \frac{\bar{h}^2}{2} \approx W\phi_i g \Delta p \frac{H^2}{8} \quad (21)$$

Note that since the area of permeable wall above the window is half that below the window, the mean airspeed of air flowing out through the wall is twice that of air flowing in underneath. This has two practical consequences:

- The heat loss per unit area above the window will be very much greater than that below the window (Taylor et al. 1997).
- The risk of interstitial condensation above the window is greatly increased.

Example 2: envelope with discrete openings. The above problems can be eliminated by creating an opening in the ceiling and raising the height, H , at which air is vented from the building by adding a ridge vent or chimney (Figure 3). This has the effect of raising the NPL. Assume, for simplicity, that the vent is of breadth, B , running the length of the building, W . Application of Equation 18 for the geometry in Figure 3 gives:

$$\frac{1}{2} \phi_r \Delta p E^2 \left\{ \frac{h_1}{E} \left(\frac{2\bar{h}}{E} - \frac{h_1}{E} \right) - \frac{h_2}{E} \left(\frac{2\bar{h}}{E} - \frac{h_2}{E} \right) + \left(\frac{2\bar{h}}{E} - 1 \right) \right\} - CB \left(2gE \frac{\Delta p}{\rho} \right)^{1/2} \left(\frac{H}{E} - \frac{\bar{h}}{E} \right)^{1/2} = 0 \quad (22)$$

This nonlinear equation can be solved iteratively for \bar{h} .

A summary of the results of calculation of the height of the NPL for the building geometry in Figure 3 is presented in Table 1. An indoor-outdoor temperature difference of 20°C, a wall permeance of 0.116 m³/m²hPa, and a ridge discharge coefficient of 0.6 are assumed.

These results show that the NPL is just below the highest discrete opening. This is because the pressure drop across the opening is much less than that across the permeable wall. A building with an airtight horizontal ceiling would behave like the generic building in Figure 4. Real ceilings are not airtight and the effect of air flowing through crevices in the ceiling (albeit with pressure losses) will be to raise the NPL to around ceiling height. The exact location will depend on whether the loft is heated and if it is ventilated at the eaves.

Pressure Variations Around the Envelope Due to Wind

Wind blowing over a building tends to create a high pressure on the windward side and a low pressure on the leeward side (Figure 6). The pressure rise or fall is given by

$$\Delta P_w = C_p \left(\frac{\rho V^2}{2} \right) \quad (23)$$

TABLE 1
Sample Calculated Values for the Height of the NPL

H (m)	3.00	4.00	5.00	6.00	3.00	6.00
H/E	1.00	1.33	1.67	2.00	1.00	2.00
B (m)	0.02	0.02	0.02	0.02	0.10	0.10
\bar{h}/E	0.98	1.29	1.57	1.87	1.00	1.99

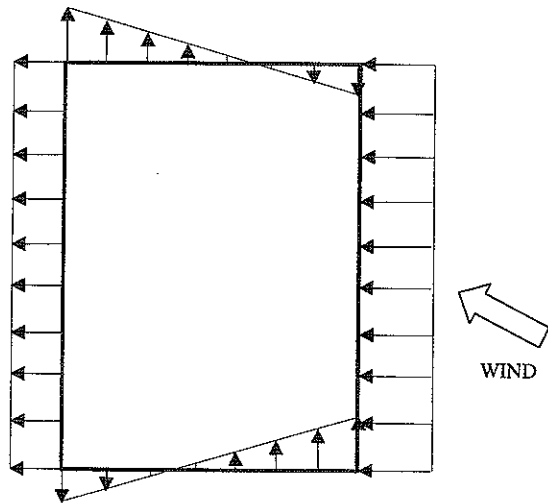

Figure 6 Pressure distribution around the building due to wind.

where V is the local wind speed and ρ is the air density. The term in brackets is the dynamic or velocity pressure of the wind. The pressure coefficient C_p has to be measured experimentally from wind tunnel tests on a scale model or by using established correlations. The positive pressure on the windward face of a building is approximately 0.5-0.8 times the dynamic pressure of the wind, and on the leeward side, the negative pressure is about 0.3-0.4 times the same pressure. The net wind pressure acting across a building is approximately equal to the wind dynamic pressure.

Swami and Chandra (1988) developed a particularly useful correlation from a database containing 544 average surface pressure coefficients for predominantly low-rise buildings, with some data from high-rise buildings. The pressure coefficient for a surface is normalized with respect to the C_p at a wind angle of zero degrees. The following relationship was also found between the normalized coefficient, NC_p , for each surface, wind incidence angle, α , and the building side logarithmic ratio, G :

$$NC_p = \ln \left[\begin{aligned} &1.248 - 0.703 \sin\left(\frac{\alpha}{2}\right) - 1.175 \sin^2(\alpha) + 0.131 \sin^3(2\alpha G) \\ &+ 0.769 \cos\left(\frac{\alpha}{2}\right) + 0.07 G^2 \sin^2\left(\frac{\alpha}{2}\right) + 0.717 \cos^2\left(\frac{\alpha}{2}\right) \end{aligned} \right] \quad (24)$$

As a general observation, they found that wind angle and building side ratio significantly affected C_p . They also concluded that uncertainties in the estimation of the site wind speed and the effect of surrounding buildings are likely to be equal to or greater than the uncertainty in estimating C_p from the correlation.

The Swami and Chandra correlation is applied to a simple dynamically insulated building (Figure 7) in order to draw

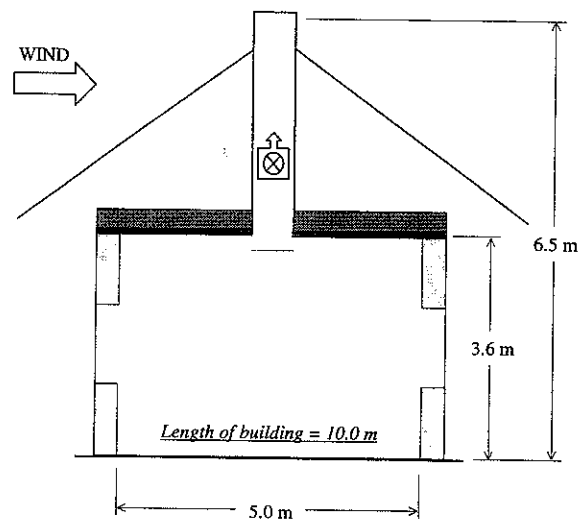

Figure 7 Building with air permeable walls.

some general conclusions about the performance of dynamic insulation under simultaneous wind and stack pressures. It is assumed for simplicity that the walls are of uniform permeance ($0.116 \text{ m}^3/\text{m}^2\text{hPa}$), apart from doors and windows, which are leak-tight. With dimensions as shown in Figure 7, the building has a gross volume of 180 m^3 . This volume together with the percentages of impermeable surfaces for doors and windows in Table 2, 20°C temperature difference between inside and out, and a 10 Pa depressurization produced by an extract (suction) fan give a ventilation rate of 1 ach in zero wind. This is used as the reference house.

Increasing the volume of the building (giving proportionally less surface area) or increasing the amount of glazing would require either an increase in depressurization or an increase in the permeance of the walls to achieve a ventilation rate of 1 ach. The terrain and shielding of the house are taken into account by calculating the wind speed at ridge height using the standard correction equation for surface terrain roughness and height (Liddament 1988).

$$V = \beta \left(\frac{z}{10}\right)^\gamma V_{ref} \quad (25)$$

where the terrain description coefficients β and γ are obtained from knowledge of the site. The reference wind speed, V_{ref} , is assumed to be measured on flat terrain at a height of 10 m and the wind incident at 0° to the west wall.

TABLE 2
Percentage Impermeable Surfaces

West	North	East	South
25%	0%	10%	25%

TABLE 3
Wind Speed Corrections for Height and Terrain

Terrain Description	γ	β
Flat terrain with some isolated obstacles	0.15	1.00
Rural areas with low buildings	0.20	0.85
Urban, industrial, or forest areas	0.25	0.67
Center of large city, e.g., Manhattan	0.35	0.47

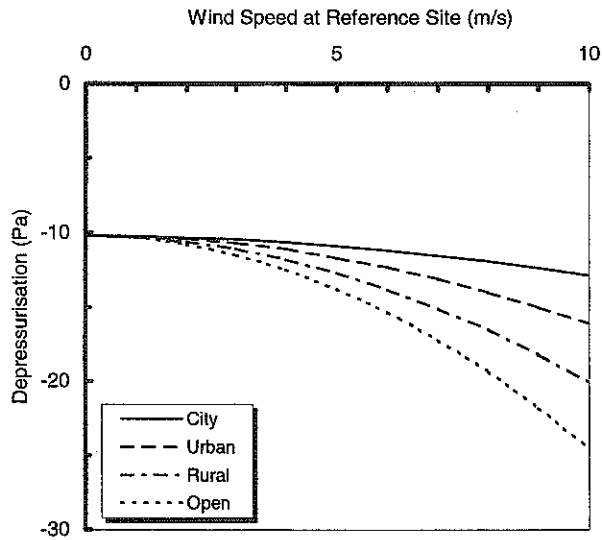

Figure 8 Depressurization as a function of wind speed.

The depressurization required for maintaining a ventilation rate at 1 ach for the building in each of the diverse surroundings in Table 3 is presented, as a function of wind speed (at the reference site), in Figure 8.

At wind speeds of up to 1 m/s, the depressurization required is independent of wind speed and surroundings. For rural or exposed locations with wind speeds in excess of 10 m/s, the depressurization can exceed 20 Pa for the reference building. Liddament (1988) suggests that one should not exceed 10 Pa depressurization in buildings with naturally aspirated furnaces in order to prevent problems with backdrafts down flues. Furthermore, 10 Pa should not be exceeded across doors and windows in order to prevent difficulties in opening them or to prevent them slamming shut (Dalehaug 1993). While none of these problems is insurmountable, we propose to retain the 10 Pa depressurization limit for domestic buildings. As will be illustrated later in this section, the wind speed, location, temperature difference, and depressurization can all be used to determine the required permeance of the walls at the design stage.

As the wind speed increases, airflow through the windward wall increases, yet through the leeward and side walls it

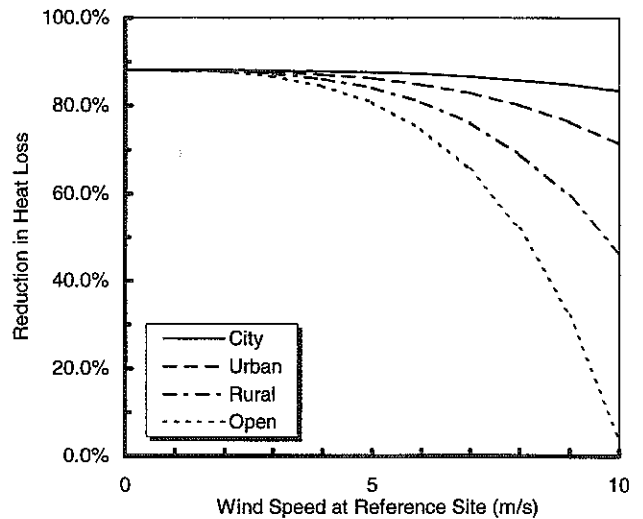

Figure 9 Percentage reduction in wall heat loss as a function of wind speed.

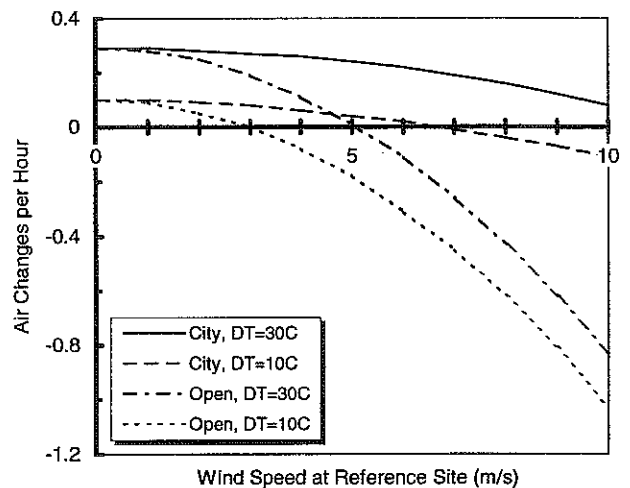

Figure 10 Air change rate as a function of wind speed.

decreases. This means that the windward wall experiences the greatest reduction in conductive heat losses (Taylor et al. 1996). The overall reduction in wall heat losses is shown in Figure 9 for different levels of exposure. For an open site with a wind speed of 10 m/s, the total heat losses through the building walls are only 3% lower than for an equivalent airtight construction, so that for this type of exposure there is little to be gained by an air permeable construction. The ventilation losses remain constant since the ventilation rate is maintained at 1 ach. Only for open terrain with wind speeds in excess of 9 m/s was the depressurization on the lee side of the building sufficient to draw air out through the walls. The general conclusion is that dynamically insulated buildings can be designed such that even at high wind speeds air will always flow into the buildings. On very exposed sites, however, it may be necessary to provide wind screening for the building.

The importance of having an extract fan to maintain the air flow inwards through the wall is illustrated in Figure 10. In these calculations, the mechanical extract flow has been set to zero and the internal pressure is also assumed to be constant at 0 Pa at all wind speeds since the interior is open to atmospheric pressure via the roof vent. On an open site, wind speeds in excess of 3 m/s at the reference site cause a negative air change rate when there is only a 10°C temperature difference between inside and out. What this means is that more air is being drawn out through the leeward and side walls (Figure 6) than is being blown in through the windward wall, with the balance supplied by air being drawn down the roof vent. With larger temperature differences, the stronger stack effect can delay the onset of this downdraft. Figure 10 also shows that on a very sheltered city center site with a temperature difference of 30°C no backdraft will be experienced, provided wind speeds at the reference site do not exceed 10 m/s. When air flows out through the walls, the fabric heat losses can be excessive (Figure 11). To sum up, a naturally ventilated, dynamically insulated building is feasible in a very sheltered site with a large indoor-outdoor temperature difference. In practice, however, an extract fan will usually be required to overcome the negative wind pressure around a building.

The performance of a dynamically insulated building can be made largely independent of wind direction by choosing a building form with symmetry centered around a central vertical axis, such as a circular dome. For more conventional buildings, an idea that has emerged recently for creating constant depressurization within a building, independent of wind direction, is to replace the roof ridge with a trough, with louvers in the side of the trough (Field and Pearson 1997). Alternatively, making the outer cladding a good wind barrier could eliminate the problems associated with the variation in pressure around the outside of a building due to wind. For example, having a

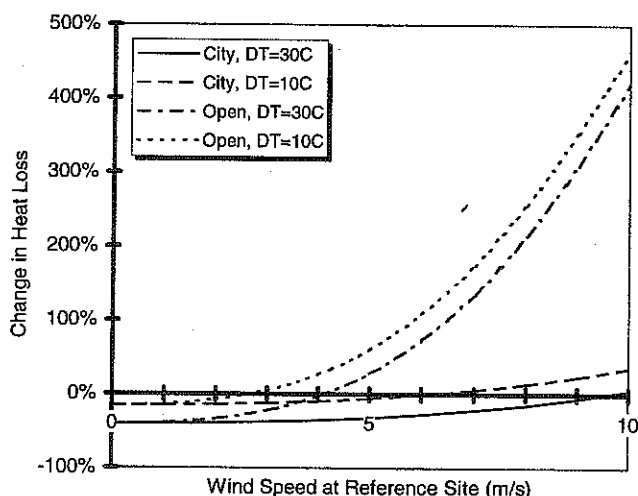

Figure 11 Percentage change in wall heat loss as a function of wind speed.

continuous cavity around the building that was sufficiently wide would enable any pressure differences to be equalized effectively.

The following illustration will show how all of the above influences of the internal and external environments can be accommodated by an appropriate choice of the air permeance of the envelope. Consider a single-story building with a floor plan 10 m × 10 m, wall height 3.6 m, vent height 6.5 m, and percentages of impermeable surfaces (glazing, doors, etc.) specified in Table 2. The building is situated on a rural site with the building axis oriented north-south, with a westerly wind, outdoor air temperature of 0°C and indoor temperature of 20°C. Assume also that there will be an extract fan to provide a ventilation rate of 1 ach at a depressurization of 10 Pa. Then the air permeance required for the wall is 0.506 m³/m²hPa. One can further predict that this will be satisfactory up to a wind speed of 9 m/s, above which the heat losses will exceed those of a similar airtight envelope.

The effect of wind gusts can be readily ignored in practice. If, for example, the minimum inward airflow is planned to be 1 m³/m²h but changes to 5 m³/m²h outward for 30 seconds, then the air at the inner surface will have moved only 42 mm into the insulation. When normal pressure conditions are reestablished, the airflow will be as planned. Problems, such as condensation, may occur only if the flow disturbance lasts long enough to make air flow from inside to outside. For a wall with 200 mm of insulation, a gust of 5 m³/m²h in the same direction would have to persist for about two minutes before risking condensation. The effects of condensation would be reversed naturally when the design airflow rate and direction are reestablished.

The magnitude of the pressure fluctuations found on the surfaces of buildings varies rapidly with time because of wind turbulence. However, use of average wind pressures to calculate pressure differences is often sufficient to determine average infiltration values. In residential buildings, the magnitude of the wind pressure differences across a wall averaged over 20 minutes seldom exceeds ±5 Pa, and in many cases the average is less than ±2.5 Pa (ASHRAE 1993).

In the United Kingdom, the probability of very low outdoor temperatures in conjunction with high wind speeds is relatively low, so it would be incorrect to use minimum outdoor temperatures and maximum wind speeds when estimating the depressurization for a dynamically insulated building. Taylor and Imbabi (1998) have considered multi-story buildings. While the Swami and Chandra (1988) correlation is very useful for the initial stages of a design, where the objective is to explore various building designs and ventilation strategies, it must be remembered that it provides estimates only of the average pressure on the walls. Locally on each wall the external pressure will differ from this average and there will still be the possibility of air flowing out through the wall in regions where the external pressure is lower than the mean. This can be overcome by including factors of safety in design,

such as increasing the ventilation rate or planting wind-shelter belts around the building. However, it would still be advisable to confirm design calculations by wind tunnel tests on a scale model of the building and the surrounding terrain and wind shields.

AIR PERMEABLE CEILINGS

While the discussion so far has dealt with the problems of constructing dynamically insulated walls, this has not been the most common way of implementing dynamic insulation. A great many, if not the majority, of examples of dynamically insulated buildings in Austria (Bartussek 1981) and Scandinavia (Liddell et al. 1996) use dynamically insulated ceilings in conjunction with airtight walls. For single-story buildings, this makes a great deal of sense for the following reasons. First, the surface area for heat loss through the ceiling is greater than the walls, even before allowances are made for windows and doors, which could easily reduce the permeable wall surface by 30% to 40%. With airtight walls, wind loading and stack effect do not need to be considered.¹ Second, the air coming in through a dynamically insulated wall, although pre-warmed, is still a few degrees cooler than the internal air temperature (Taylor and Imbabi 1997). Relatively cool air will descend under gravity, setting up a natural convective flow in the wall boundary layer. Introducing skirting-level heating can eliminate this cold, downward draft. If this air is introduced at ceiling level instead, there will be greater opportunity for mixing with the warm air in the room before it reaches the occupants. Also, introducing air through the ceiling makes it easier to ventilate rooms in the interior of the building.

The general concept of using a dynamically insulated ceiling is shown in Figure 12a. The loft is well ventilated, and at ambient outdoor air temperature, there is no need to insulate the roof itself either conventionally or dynamically. This configuration makes it easier to install an air-to-air heat exchanger (Taylor and Imbabi 1996) for greater heat recovery (see Figure 12b).

If a heat exchanger is installed in the ventilation system, a supply fan will be needed in addition to the extract fan to maintain the building at a relatively low depressurization of 5-10 Pa. Further advantages of dynamically insulated ceilings are as follows:

- The ceiling is not blocked by furniture as easily as a wall.
- The ceiling is less susceptible to damage and does not require a wearing surface.
- An acceptable decorative finish will be easier to achieve than on a wall.

¹ The airtight wall is an inherently more robust design, since it is much less dependent on external and internal environments. It can accommodate greater variation in occupant lifestyles, ranging from the intermittent occupancy of a single person to a family with very young children, or elderly people, who stay at home all day.

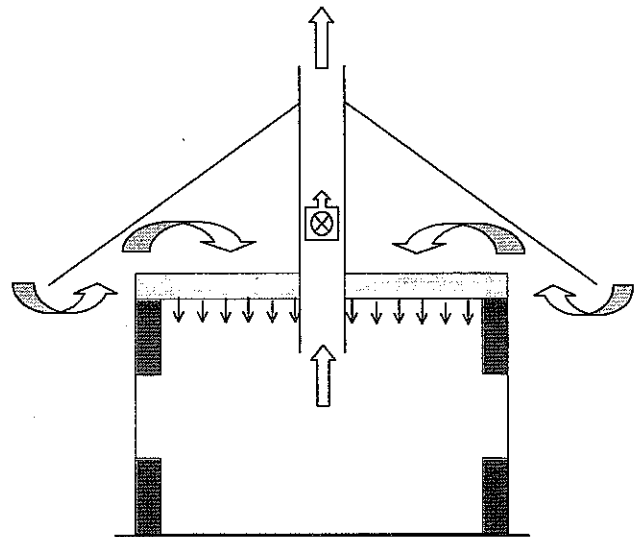

(a) Air permeable ceiling.

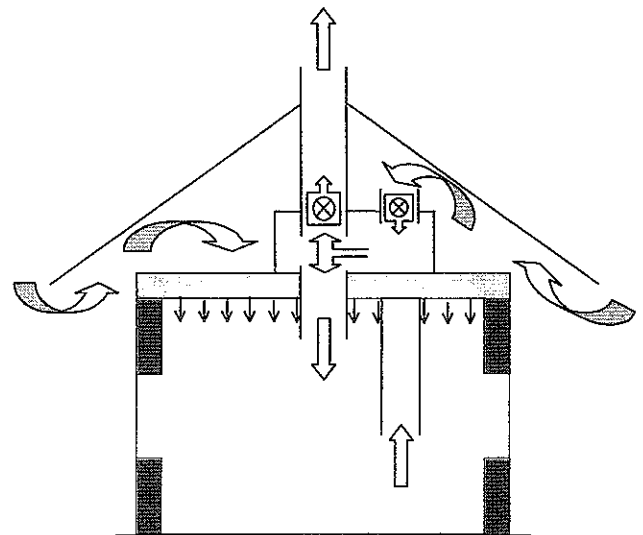

(b) Air permeable ceiling with air-to-air heat exchanger.

Figure 12 Dynamically insulated ceilings.

- It is easier to install in an existing building.
- Inspection of insulation for signs of mold growth is easy.
- In the unlikely event of mold growth, insulation is easily replaced.

The only disadvantages of dynamically insulated ceilings would seem to be the following:

- The loft cannot be boarded over and used for storage unless staging standing off the joists with clear ventilation underneath is erected.
- Except for small floor plans, more than one vent to outside may be needed.

CONCLUSIONS

With air permeable envelopes, it is imperative that good environmental design principles be applied. The mere fact that dynamic insulation relies on outdoor air flowing through the wall to the inside means that the internal and external environments are intimately coupled. This is highlighted by the fact that the required air permeance of the envelope can be readily calculated from the following design information:

- a. Building dimensions
- b. Building form
- c. Proportion and location of glazing and doors
- d. Indoor and outdoor temperatures
- e. Ventilation rate
- f. Depressurization
- g. Wind speed and direction at reference site
- h. Local terrain and wind shielding

Changes in temperature, indoor or out, and changes in wind speed and direction will influence the behavior of a dynamically insulated wall and must be taken into account in the design. Air permeable ceilings are less prone to the effects of wind due to the attic acting as a large plenum.

Equations have been derived for calculating the neutral pressure level (NPL) in buildings that have permeable walls or roofs. Data on the air permeability of materials, which is essential for the design of buildings incorporating dynamic insulation, is presented.

To ensure adequate depressurization of the building under likely wind speeds and directions, the architect has the choice between mechanical and natural ventilation. Mechanical ventilation is easier to design, permits a greater choice of site, and is more predictable in operation, but it does incur additional costs. Natural ventilation is more challenging to design since the wind speed, direction, and site conditions will influence the building design to a great extent. A naturally ventilated, dynamically insulated building would appear to be feasible only in a very sheltered site or one with a large indoor-outdoor temperature difference. Proposals for a dynamically insulated building using natural ventilation would have to be tested in a wind tunnel in order to gain confidence that the design intentions would be fulfilled.

Air permeable ceilings are technically simpler than walls to design and construct with the further advantage of providing a greater energy saving in single-story buildings.

ACKNOWLEDGMENTS

This work has been funded by the Engineering and Physical Sciences Research Council (EPSRC), Grant Reference GR/K23461. The authors are grateful to Mr. Conrad Weidemann of Camphill Architects, Beildside (Aberdeenshire) for supplying data for their dynamically insulated house.

NOMENCLATURE

- a = permeance ratio
 A = area (m^2)

- C = discharge coefficient of opening
 C_p = pressure coefficient for building surface
 E = height to eaves (m)
 g = acceleration of gravity (m/s^2)
 G = natural log of ratio of width of wall under consideration to width of adjacent wall
 h = height from neutral pressure level (NPL) (m)
 \bar{h} = height of NPL above datum (m)
 H = height of highest opening (m)
 L = thickness (m)
 n = exponent in pressure flow relationship, number of layers in building envelope, air change rate (h^{-1})
 NC_p = normalized pressure coefficient
 P = pressure (Pa)
 P_s = stack pressure (Pa)
 P_{so} = maximum outward pressure due to stack effect (Pa)
 P_w = wind pressure (Pa)
 Q = air flow rate (m^3/h)
 T = temperature ($^{\circ}C$)
 v = air flow velocity through envelope (m/h)
 \bar{v} = average air flow velocity through the ridge opening (m/h)
 V = wind speed (m/s)
 z = height (m)

Greek Symbols

- α = wind direction (degrees)
 β, γ = terrain description coefficients
 ϕ = air permeance of component (m^3/m^2hPa)
 Φ = air permeability of material (m^2/hPa)
 ρ = density of air (kg/m^3)

Subscripts

- 1 = outdoor
 2 = indoor
 d = discrete surface
 p = permeable surface
 ref = reference

REFERENCES

- ASHRAE. 1993. *1993 ASHRAE handbook—fundamentals*. Chapter 23, Infiltration and Ventilation. Atlanta: American Society of Heating, Refrigeration and Air-Conditioning Engineers, Inc.
- Bartussek, H. 1981. *Poren-luftung (Porous ventilation)*. Vienna: Osterreichisches Kuratorium fur Landtechnik.
- Bartussek, H. 1989. Natural ventilation by thermal buoyancy and by outside convections: Practical application of natural ventilation systems with chimneys and breathing

- ceilings. Dublin: *Proceedings of the 11th International Congress on Agricultural Engineering*, pp. 251-267.
- Bruce, J.M. 1978. Natural convection through openings and its application to cattle building ventilation. *Journal of Agricultural Engineering Research*, vol. 23, pp. 131-167.
- Dalehaug, A. 1993. Dynamic insulation in walls. *Research Report No. 53*, Hokkaido Prefectural Cold Region Housing and Urban Research Institute.
- Field, J., and A. Pearson. 1997. Natural aspiration, building analysis: University of Derby LRC. *Building Services Journal*, vol. 19, no. 9, pp. 16-20.
- Liddament, M.W. 1988. The calculation of wind effect on ventilation. *ASHRAE Transactions*, 94(2): 1645-1660.
- Liddell, H., D. Roalkvam, I. McKenzie. 1996. Pore ventilation. CIBSE / ASHRAE Joint National Conference, London. Preprint copy.
- Orme, M., M. Liddament, and A. Wilson. 1994. An analysis and data summary of the AIVCs numerical database, *Technical Note AIVC 44*, Air Infiltration and Ventilation Centre, Coventry.
- Swami, M.V., and S. Chandra. 1988. Correlations for pressure distribution on buildings and calculation of natural-ventilation air flow. *ASHRAE Transactions*, 94(1): 243-266.
- Taylor, B.J., D.A. Cawthorne, M.S. Imbabi. 1996. Analytical investigation of the steady-state behavior of dynamic and diffusive envelopes. *Building and Environment*, vol. 31, no. 6, pp. 519-525.
- Taylor, B.J., and M.S. Imbabi. 1996. Dynamic insulation - A systems approach. *Proceedings of the Building Physics in Northern Climates Conference*, Espoo, Finland, 9-10 September, vol. 2, pp. 83-90.
- Taylor, B.J., and M.S. Imbabi. 1997. The effect of air film thermal resistance on the behavior of dynamic insulation. *Building and Environment*, vol. 32, no. 5, pp. 397-404.
- Taylor, B.J., and M.S. Imbabi. 1998. Dynamic insulation in multi-story buildings. Accepted by CISBE for publication in *Building Services Engineering, Research, and Technology*.
- Taylor, B.J., R. Webster, M.S. Imbabi. 1997. The use of dynamic and diffusive insulation for combined heat recovery and ventilation in buildings. *BEFAC/EPSC Sustainable Building Conference*, Abingdon, U.K., 5-6 February, pp. 168-174.

APPENDIX A
TABLE A1
Measured Air Permeability of Building Materials (Taylor et al. 1996)

Material	Density (kg/m ³)	Thickness of Layer (mm)	Permeance (m ³ /m ² hPa)	Pressure Drop (Pa)*
Plasterboard	-	12	8.81×10 ⁻⁴	1140
Thermal block	850	100	1.6×10 ⁻⁴	526
Fiberboard	-	12	0.116	8.6
Pumalite	870	100	0.36	2.8
Cellulose/wet blown	47	200	1.50	0.67
Cellulose/dry blown	65	150	1.67	0.60
Sheep's wool	28	140	13.0	0.08

* Pressure drop calculated at flow rate of 1 m³/m²h.